

C8051F500 DEVELOPMENT KIT USER'S GUIDE

1. Relevant Devices

The C8051F500 Development Kit is intended as a development platform for the microcontrollers in the C8051F50x/51x MCU family.

- The target board included in this kit is provided with a presoldered **C8051F500** MCU (LQFP48 package) and a **C8051F502** (QFN32 package).
- Code developed on the C8051F500 can be easily ported to the other members of this MCU family.
- Refer to the C8051F50x/51x data sheet for the differences between the members of this MCU family.

2. Kit Contents

The C8051F500 Development Kit contains the following items:

- C8051F500 Target Board
- C8051Fxxx Development Kit Quick-Start Guide
- AC to DC Power Adapter
- USB Debug Adapter (USB to Debug Interface)
- Two USB Cables

3. Hardware Setup Using a USB Debug Adapter

The target board is connected to a PC running the Silicon Laboratories IDE via the USB Debug Adapter as shown in Figure 1.

1. Connect the USB Debug Adapter to one of the **DEBUG** connector on the target board (**DEBUG_A** or **DEBUG_B**) with the 10-pin ribbon cable. The recommended connection is to **DEBUG_A** as this microcontroller is the primary MCU on the board and more peripherals are easily available.
2. Connect one end of the USB cable to the USB connector on the USB Debug Adapter.
3. Connect the other end of the USB cable to a USB Port on the PC.
4. Connect the AC/DC power adapter to power jack **P4** on the target board.

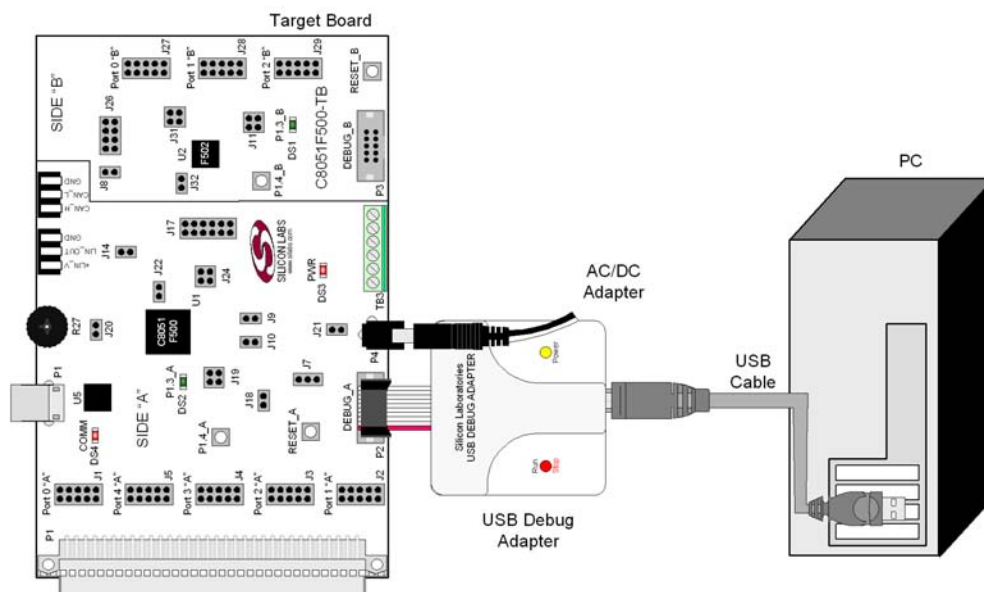

Figure 1. Hardware Setup using a USB Debug Adapter

C8051F50x/51x

Notes:

1. Use the Reset button in the IDE to reset the target when connected using a USB Debug Adapter.
2. Remove power from the target board and the USB Debug Adapter before connecting or disconnecting the ribbon cable from the target board. Connecting or disconnecting the cable when the devices have power can damage the device and/or the USB Debug Adapter.

4. Software Setup

Simplicity Studio greatly reduces development time and complexity with Silicon Labs EFM32 and 8051 MCU products by providing a high-powered IDE, tools for hardware configuration, and links to helpful resources, all in one place.

Once Simplicity Studio is installed, the application itself can be used to install additional software and documentation components to aid in the development and evaluation process.

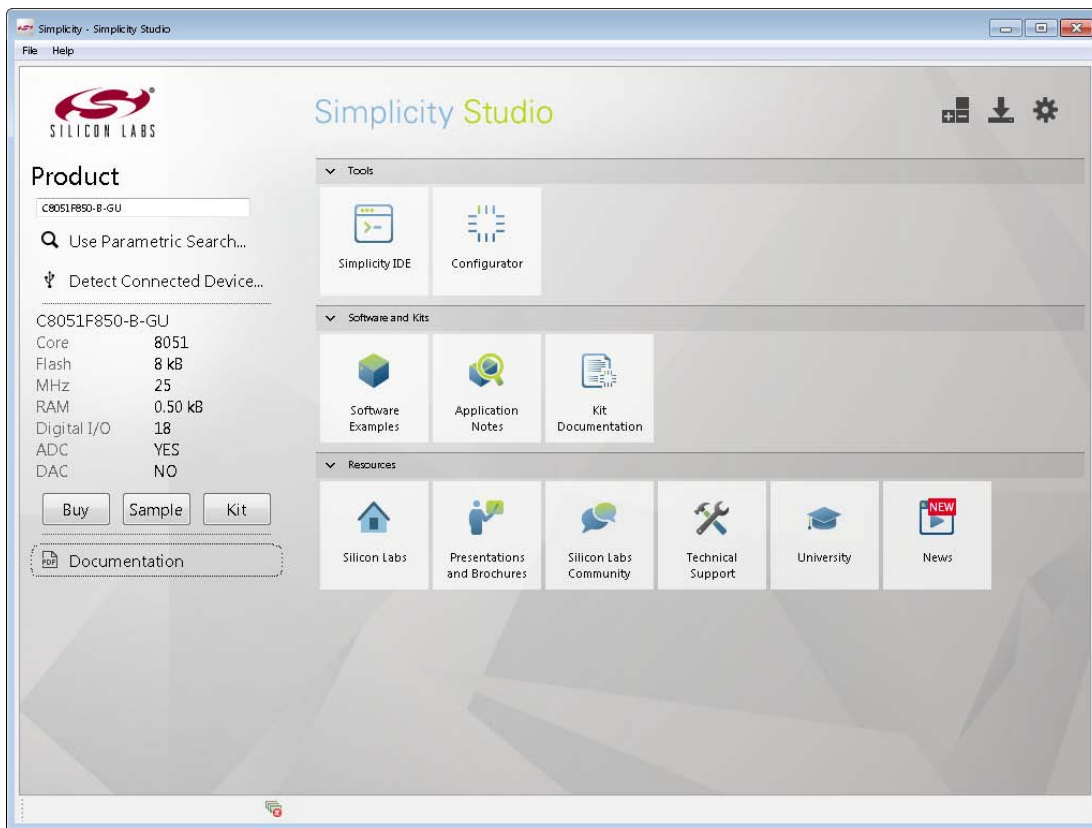

Figure 2. Simplicity Studio

The following Simplicity Studio components are required for the C8051F500 Development Kit:

- 8051 Products Part Support
- Simplicity Developer Platform

Download and install Simplicity Studio from www.silabs.com/8bit-software or www.silabs.com/simplicity-studio. Once installed, run Simplicity Studio by selecting **Start**→**Silicon Labs**→**Simplicity Studio**→**Simplicity Studio** from the start menu or clicking the **Simplicity Studio** shortcut on the desktop. Follow the instructions to install the software and click **Simplicity IDE** to launch the IDE.

The first time the project creation wizard runs, the **Setup Environment** wizard will guide the user through the process of configuring the build tools and SDK selection.

In the **Part Selection** step of the wizard, select from the list of installed parts only the parts to use during development. Choosing parts and families in this step affects the displayed or filtered parts in the later device selection menus. Choose the C8051F50x/51x family by checking the **C8051F50x/51x** check box. Modify the part selection at any time by accessing the **Part Management** dialog from the **Window**→**Preferences**→**Simplicity Studio**→**Part Management** menu item.

Simplicity Studio can detect if certain toolchains are not activated. If the **Licensing Helper** is displayed after completing the **Setup Environment** wizard, follow the instructions to activate the toolchain.

4.1. Running Blinky

Each project has its own source files, target configuration, SDK configuration, and build configurations such as the **Debug** and **Release** build configurations. The IDE can be used to manage multiple projects in a collection called a workspace. Workspace settings are applied globally to all projects within the workspace. This can include settings such as key bindings, window preferences, and code style and formatting options. Project actions, such as build and debug are context sensitive. For example, the user must select a project in the **Project Explorer** view in order to build that project.

To create a project based on the Blinky example:

1. Click the **Software Examples** tile from the Simplicity Studio home screen.
2. In the **Kit** drop-down, select **C8051F500 Development Kit**, in the **Part** drop-down, select **C8051F500**, and in the **SDK** drop-down, select the desired SDK. Click **Next**.
3. Select **Example** and click **Next**.
4. Under **C8051F500 Development Kit**, select **F50x Blinky**, click **Next**, and click **Finish**.
5. Click on the project in the **Project Explorer** and click **Build**, the hammer icon in the top bar. Alternatively, go to **Project**→**Build Project**.
6. Click **Debug** to download the project to the hardware and start a debug session.
7. Press the **Resume** button to start the code running. The LED should blink.



8. Press the **Suspend** button to stop the code.



9. Press the **Reset the device** button to reset the target MCU.



10. Press the **Disconnect** button to return to the development perspective.



4.2. Simplicity Studio Help

Simplicity Studio includes detailed help information and device documentation within the tool. The help contains descriptions for each dialog window. To view the documentation for a dialog, click the question mark icon in the window:



This will open a pane specific to the dialog with additional details.

The documentation within the tool can also be viewed by going to **Help**→**Help Contents** or **Help**→**Search**.

C8051F50x/51x

4.3. CP210x USB to UART VCP Driver Installation

The Target Board includes a Silicon Labs CP210x USB-to-UART Bridge Controller. Device drivers for the CP210x need to be installed before the PC software can communicate with the MCU through the UART interface.

1. After opening Simplicity Studio for the first time, a dialog will prompt to install the CP210x drivers. Click **Yes**. The drivers can also be installed at any time by going to **Help**→**Install Drivers**→**CP210x VCP USB Drivers**.
2. Accept the license agreement and follow the steps to install the driver on the system. The installer will let you know when your system is up to date. The driver files included in this installation have been certified by Microsoft.
3. To complete the installation process, connect the included USB cable between the host computer and the USB connector (P4) on the Target Board. Windows will automatically finish the driver installation. Information windows will pop up from the taskbar to show the installation progress.
4. If needed, the driver files can be uninstalled by selecting **Windows Driver Package—Silicon Laboratories...** option in the **Programs and Features** window.

4.4. Configuration Wizard 2

The Configuration Wizard 2 is a code generation tool for all of the Silicon Laboratories devices. Code is generated through the use of dialog boxes for each of the device's peripherals.

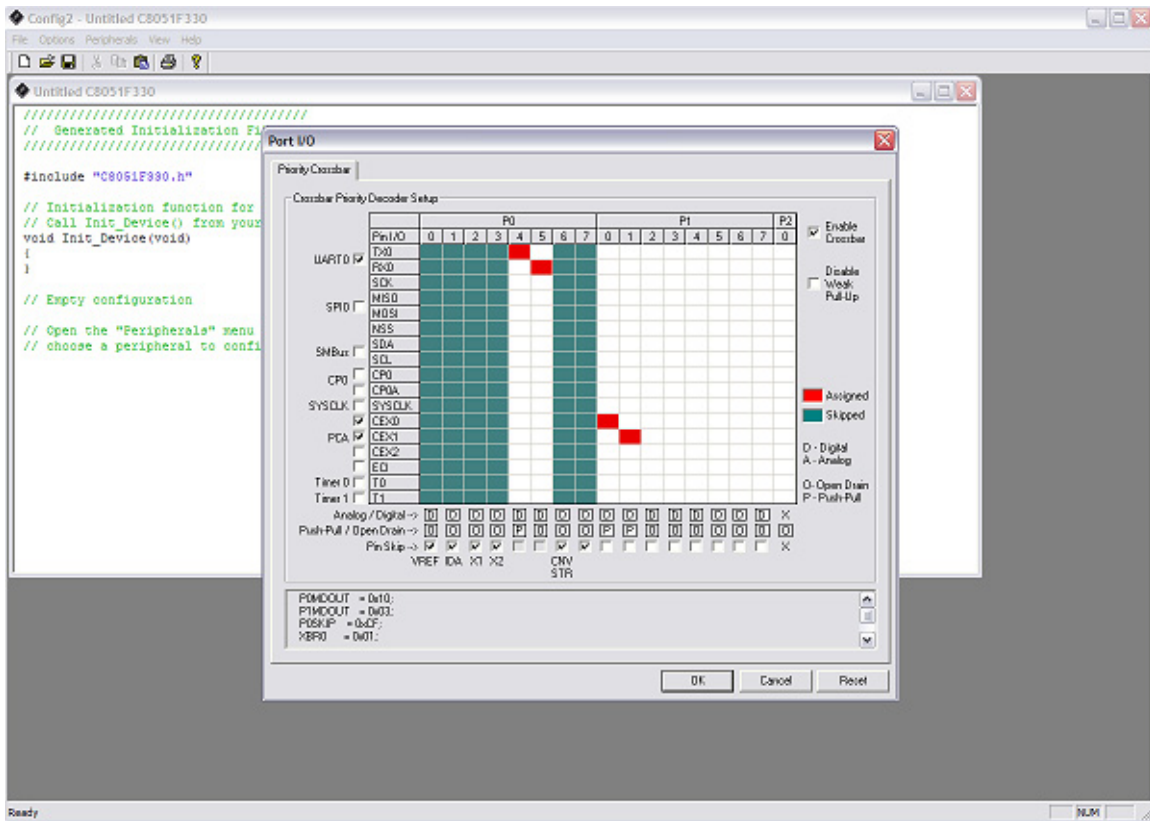

Figure 3. Configuration Wizard 2 Utility

The Configuration Wizard 2 utility helps accelerate development by automatically generating initialization source code to configure and enable the on-chip resources needed by most design projects. In just a few steps, the wizard creates complete startup code for a specific Silicon Laboratories MCU. The program is configurable to provide the output in C or assembly. For more information, please refer to the Configuration Wizard 2 help available under the **Help** menu in Config Wizard 2.

5. Target Board

The C8051F500 Development Kit includes a target board with a **C8051F500** (Side A) and **C8051F502** (Side B) device preinstalled for evaluation and preliminary software development. Numerous input/output (I/O) connections are provided to facilitate prototyping using the target board. Refer to Figure 4 for the locations of the various I/O connectors. Figure 5 on page 7 shows the factory default shorting block positions. A summary of the signal names and headers is provided in Table 12 on page 14.

Table 1. Target Board Connector Summary

Connector	Description
J1-J5	Side A: Port 0 through Port 4 headers
J7	Header to choose between +5V from Debug Adapter (P2) or +5V from on-board regulator (U6)
J8	Side B: CAN Transceiver (U4) power connector
J9, J10	Side A: External crystal enable connectors
J11	Side B: Connects P1.3_B LED and P1.4_B Switch to MCU port pins
J14	Side A: CAN Transceiver (U3) power connector
J17	Side A: Connects MCU to three separate transceivers (UART(U5), CAN(U3) and LIN(T1))
J18	Side A: Connects VIO to VIO_A_SRC which powers the P1.2 potentiometer, the /RST_A pin pull-up, and P1.4_A Switch pull-up.
J19	Side A: Connects P1.3_A LED and P1.4_A Switch to MCU port pins
J20	Side A: Connects R27 potentiometer to port pin 1.2
J21	Connect V_HIGH node from TB1 LIN header to +5V regulator input for board power
J22	Side A: Connects decoupling capacitors C28 and C29 for MCU VREF (P0.0)
J24	Side A: Connects +5 V net to VIO and VREGIN of the MCU
J26	Side B: Connects MCU to three separate transceivers (CAN (U4) and LIN (T2))
J27-J29	Side B: Port 0 through Port 2 headers
J31	Side B: Connects +5V net to VIO and VREGIN of the MCU
J32	Side B: Connects decoupling capacitors C41 and C42 for MCU VREF (P0.0)
P1	Side A: 96-pin female connector
P2	Side A: DEBUG connector for Debug Adapter interface
P3	Side B: DEBUG connector for Debug Adapter interface
P4	Power connector (accepts input from 7 to 15 VDC unregulated power adapter)
P5	USB connector (connects to PC for serial communication)
TB1	Shared LIN Connector for Side A and B MCUs for external nodes
TB2	Shared CAN Connector for Side A and B MCUs for external nodes
TB3	Side A: Power supply terminal block

C8051F50x/51x

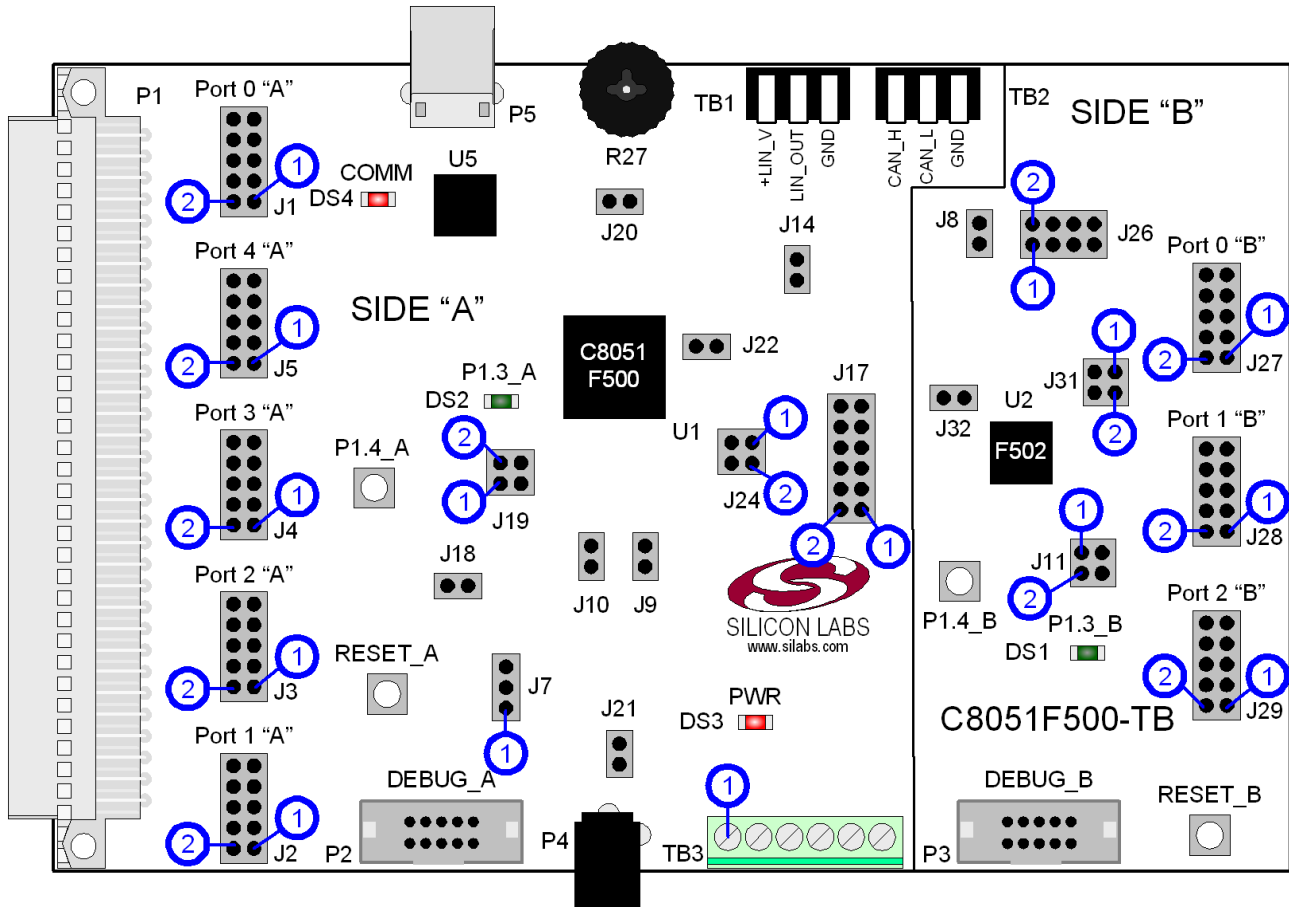

Figure 4. C8051F500 Target Board with Pin Numbers

5.1. Target Board Shorting Blocks: Factory Defaults

The C8051F500 target board comes from the factory with preinstalled shorting blocks on many headers. Figure 5 shows the positions of the factory default shorting blocks.

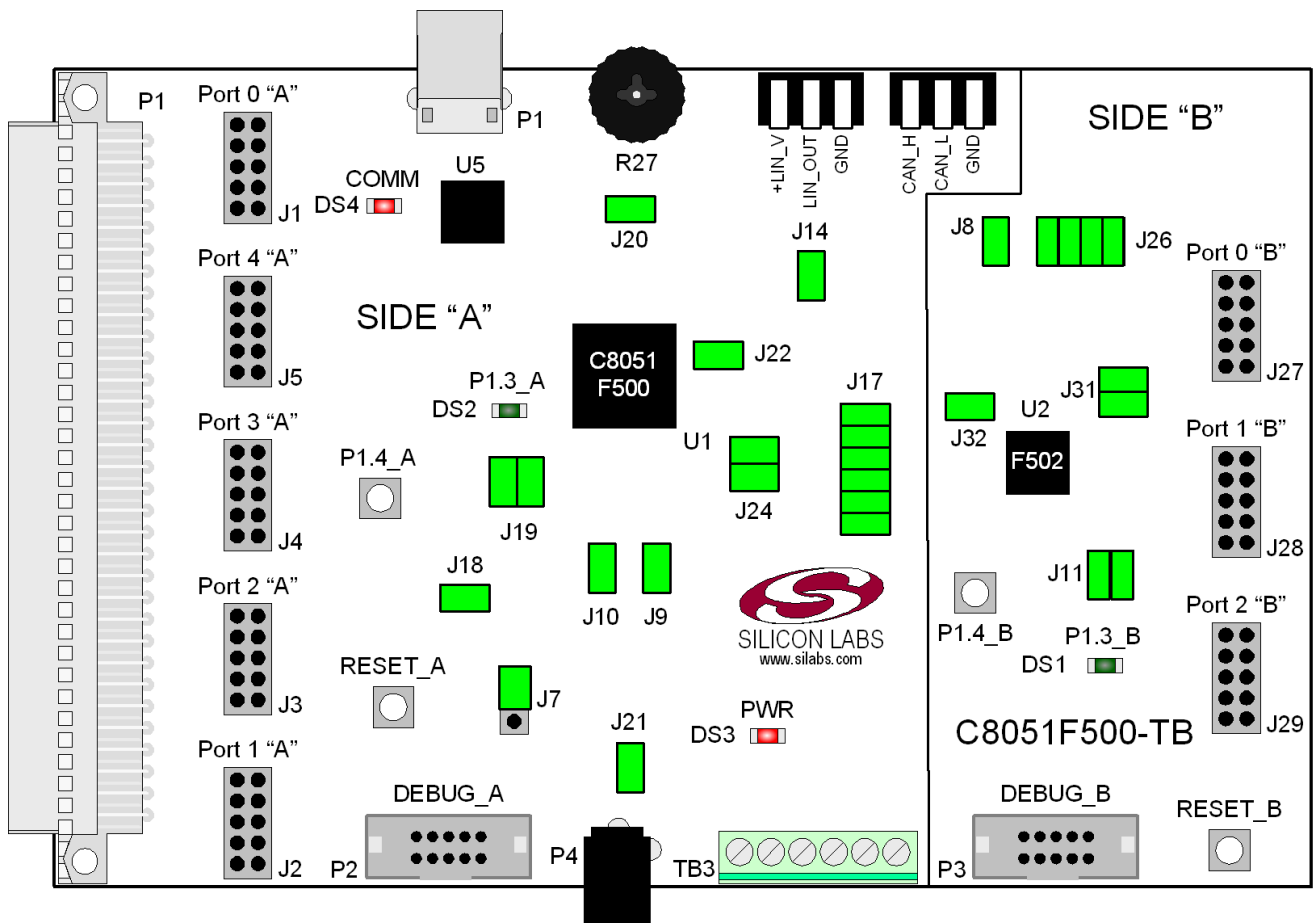

Figure 5. C8051F500 Target Board Shorting Blocks: Factory Defaults

5.2. Target Board Power Options and Current Measurement

The C8051F500 target board supports three power options:

1. 12 V dc power using the ac to dc power adapter (P4)
2. 5 V dc USB VBUS power from PC via the USB Debug Adapter (DEBUG_A)
3. 12 V dc power from the LIN external header (TB1)

The two 12V power sources are ORed together using reverse-biased diodes (Z1 and Z2). The ORed power is regulated to a 5.0V DC voltage using a LDO regulator (U6). To power the board from the USB Debug Adapter connected to DEBUG_A instead of the 12V sources, move the shorting block on the J7 header to pins 2 and 3 to select SER_PWR. The output of the regulator powers the +5VD net on the target board, and is also connected to one end of the header J24 (SIDE A) and J31 (SIDE B). Two shorting blocks can be put on each header to connect the 5V net to the VREGIN and VIO pins on the two MCUs. With the shorting block removed, a source meter can be used across the headers to measure the current consumption of the MCU.

Note: The USB Debug Adapter does not provide the necessary peak power for the CAN transceivers to operate. One of the 12V DC sources is recommended for CAN transceiver operation.

5.3. System Clock Sources

5.3.1. Internal Oscillators

The C8051F500 and C8051F502 devices installed on the target board feature a factory calibrated programmable high-frequency internal oscillator (24 MHz base frequency, $\pm 0.5\%$), which is enabled as the system clock source on reset. After reset, the internal oscillator operates at a frequency of 187.5 kHz by default but may be configured by software to operate at other frequencies. The on-chip crystal is accurate for CAN and LIN master communications and in many applications an external oscillator is not required. However, if you wish to operate the C8051F500 device (SIDE A) at a frequency not available with the internal oscillator, an external crystal may be used. Refer to the C8051F50x data sheet for more information on configuring the system clock source.

5.3.2. External Oscillator Options

The target board is designed to facilitate the installation of an external crystal. Remove shorting blocks at headers J9 and J10 and install the crystal at the pads marked Y1. Install a 10 M Ω resistor at R9 and install capacitors at C6 and C7 using values appropriate for the crystal you select. If you wish to operate the external oscillator in capacitor or RC mode, options to install a capacitor or an RC network are also available on the target board. Populate C6 for capacitor mode, and populate R3 and C6 for RC mode. Refer to the C8051F50x data sheet for more information on the use of external oscillators.

5.4. Switches and LEDs

Two push-button switches are provided on the target board for each MCU. Switch RESET_A is connected to the /RST pin of the C8051F500. Switch RESET_B is connected to the /RST pin of the C8051F502. Pressing RESET_A puts the C8051F500 device into its hardware-reset state, and similarly for RESET_B and the C8051F502 MCU. Switches P1.4_A and P1.4_B are connected to the MCU's general purpose I/O (GPIO) pins through headers. Pressing either one of these switches generates a logic low signal on the port pin. Remove the shorting block from the header to disconnect these switches from the port pins. See Table 2 for the port pins and headers corresponding to each switch.

Four LEDs are provided on the target board to serve as indicators. The red LED labeled PWR indicates presence of power to the target board. The second red LED labeled COMM indicates if the CP2102 USB-to-UART bridge (P5) is recognized by the PC. The green LED labeled with port pin name P1.3_A is connected to the C8051F500's (Side A) GPIO pin P1.3 through the header J19. Remove the shorting block from the header to disconnect the LED from the port pin. Similarly, the green LED named P1.3_B is connected to the C8051F502 (Side B) through the J11 header. See Table 2 for the port pins and headers corresponding to each LED.

Table 2. Target Board I/O Descriptions

Description	I/O	Header(s)
RESET_A	Reset (Side A)	none
RESET_B	Reset (Side B)	none
P1.4_A Switch	P1.4 (Side A)	J191[2]
P1.4_B Switch	P1.4 (Side B)	J11[1-2]
P1.3_A LED	P1.3 (Side A)	J19[3-4]
P1.3_B LED	P1.3 (Side B)	J11[3-4]
Red LED (PWR)	Power	none
Red LED (COMM)	COMM Active	none

5.5. Target Board Debug Interfaces (P2 and P3)

The debug connectors P2 (DEBUG_A) and P3 (DEBUG_B) provide access to the debug (C2) pins of the C8051F500 and C8051F502. The debug connectors are used to connect the Serial Adapter or the USB Debug Adapter to the target board for in-circuit debugging and Flash programming. Table 3 shows the DEBUG pin definitions.

Table 3. DEBUG Connector Pin Descriptions

Side A - C8051F500		Side B - C8051F502	
Pin #	Description	Pin #	Description
1	Not Connected	1	Not Connected
2, 3, 9	GND (Ground)	2, 3, 9	GND (Ground)
4	C2D_A	4	P3.0_C2D_B
5	/RST (Reset)	5	/RST_B (Reset)
6	Not Connected	6	P3.0_B
7	/RST/C2CK_A	7	/RST/C2CK_B
8	Not Connected	8	Not Connected
10	USB Power (+5VDC from P2)	10	Not Connected

5.6. Serial Interface (P5)

A USB-to-UART bridge circuit (U5) and USB connector (P5) are provided on the target board to facilitate serial connections to UART0 of the C8051F500 (Side A). The Silicon Labs CP2102 USB-to-UART bridge provides data connectivity between the C8051F500 and the PC via a USB port. The TX and RX signals of UART0 may be connected to the CP2102 by installing shorting blocks on header J17. The shorting block positions for connecting each of these signals to the CP2102 are listed in Table 4. To use this interface, the USB-to-UART device drivers should be installed as described in Section 4.3. "CP210x USB to UART VCP Driver Installation," on page 4.

Table 4. Serial Interface Header (J3) Description

Header Pins	UART0 Pin Description
J17[9–10]	UART_TX (P0.4_A)
J17[11–12]	UART_RX (P0.5_A)

5.7. CAN Interface and Network (TB2)

Both MCUs on the target board are connected to CAN transceivers through headers. The port pins assigned to the CAN peripheral on each MCU are P0.6 (CAN_TX) and P0.7 (CAN_RX). The C8051F500 (Side A) is connected to U3 through the J17 header and the C8051F502 (Side B) is connected to U4 through the J26 header. The two CAN transceivers are connected to each other and form a CAN network. Other external devices can be connected to the CAN network through the TB2 interface. The shorting block positions for connecting the MCUs to the CAN transceivers are listed in Table 5. The pin connections for the external CAN devices are listed in Table 6. The CAN transceivers are powered by the +5VREG node and connected through J8 and J14 headers.

Table 5. CAN Interface Headers (J17 and J26) Description

Header Pins	CAN0 Pin Description
J17[5–6]	CAN_TX (P0.6_A)
J17[7–8]	CAN_RX (P0.7_A)
J26[1–2]	CAN_TX (P0.6_B)
J26[3–4]	CAN_RX (P0.7_B)

Table 6. TB2 External CAN Interface Header Description

Pin #	Pin Description
1	CAN_H
2	CAN_L
3	GND

5.8. LIN Interface and Network (TB1)

Both MCUs on the target board are connected to LIN transceivers through headers. These headers assume that the MCU's crossbars are configured to put the LIN TX and RX pins on port pins P1.0 and P1.1 respectively. See the C8051F50x data sheet for crossbar configuration. The C8051F500 (Side A) is connected to the T1 transceiver through the J17 header and the C8051F502 (Side B) is connected to the T2 transceiver through the J26 header. The two LIN transceivers are connected to each other and form a LIN network. Other external devices can be connected to the LIN network through the TB1 interface. The TB1 interface also provides the option for connecting an external power source so that all LIN transceivers can use the same source voltage. This source voltage can also be used to power the target board. If an external voltage source is not provided, the LIN transceivers use the 12 V provided through the P4 wall-wart connector. See "5.2. Target Board Power Options and Current Measurement" for more power option details. The shorting block positions for connecting the MCUs to the LIN transceivers are listed in Table 7. The pin connections for the external LIN devices are listed in Table 8.

Table 7. LIN Interface Headers (J17 and J26) Description

Header Pins	LIN0 Pin Description
J17[9–10]	LIN_TX (P1.0_A)
J17[11–12]	LIN_RX (P1.1_A)
J26[5-6]	LIN_TX (P1.0_B)
J26[7-8]	LIN_RX (P1.1_B)

Table 8. TB1 External LIN Interface Header Description

Pin #	Pin Description
1	+LIN_V
2	LIN_OUT
3	GND

5.9. Port I/O Connectors (J1-J5 and J27-J29)

Each of the parallel ports of the C8051F500 (Side A) and C8051F502 (Side B) has its own 10-pin header connector. Each connector provides a pin for the corresponding port pins 0-7, +5V VIO, and digital ground. The same pin-out is used for all of the port connectors.

Table 9. Port I/O Connector Pin Description

Pin #	Pin Description
1	Pn.0
2	Pn.1
3	Pn.2
4	Pn.3
5	Pn.4
6	Pn.5
7	Pn.6
8	Pn.7
9	+5V (VIO)
10	GND (Ground)

C8051F50x/51x

5.10. Voltage Reference (VREF) Connectors (J22 and J32)

The VREF connectors can be used to connect the VREF pin from the MCU (P0.0) to external 0.1 uF and 4.7 uF decoupling capacitors. The C8051F500 (Side A) device is connected to the capacitors through the J22 header and the C8051F502 (Side B) device connects to its own set of capacitors through J32.

5.11. Expansion Connector (P1)

The 96-pin expansion I/O connector P1 is used to connect daughter boards to the main target board. P1 provides access to many C8051F500 signal pins. Pins for VREGIN, VDD, VIO, and 3.3V are also available. See Table 10 for a complete list of pins available at P1.

The P1 socket connector is manufactured by Hirose Electronic Co. Ltd, part number PCN13-96S-2.54DS, Digi-Key part number H7096-ND. The corresponding plug connector is also manufactured by Hirose Electronic Co. Ltd, part number PCN10-96P-2.54DS, Digi-Key part number H5096-ND.

Table 10. P1 Pin Listing

Pin #	Description	Pin #	Description	Pin #	Description
A-1	+3.3V	B-1	GND	C-1	N/C
A-2	N/C	B-2	N/C	C-2	N/C
A-3	N/C	B-3	N/C	C-3	N/C
A-4	N/C	B-4	N/C	C-4	N/C
A-5	N/C	B-5	N/C	C-5	N/C
A-6	N/C	B-6	N/C	C-6	N/C
A-7	N/C	B-7	N/C	C-7	N/C
A-8	N/C	B-8	N/C	C-8	N/C
A-9	N/C	B-9	N/C	C-9	N/C
A-10	N/C	B-10	P0.7_A	C-10	P0.6_A
A-11	P0.5_A	B-11	P0.4_A	C-11	P_0.3_A
A-12	P_0.2_A	B-12	P0.1_A	C-12	P0.0_A
A-13	P4.7_A	B-13	P4.6_A	C-13	P4.5_A
A-14	P4.4_A	B-14	P4.3_A	C-14	P4.2_A
A-15	P4.1_A	B-15	P4.0_A	C-15	P3.7_A
A-16	P3.6_A	B-16	P3.5_A	C-16	P3.4_A
A-17	P3.3_A	B-17	P3.2_A	C-17	P3.1_A
A-18	P3.0_A	B-18	P2.7_	C-18	P2.6_A
A-19	P2.5_A	B-19	P2.4_	C-19	P2.3_A
A-20	P2.2_A	B-20	P2.1_A	C-20	P2.0_A
A-21	P1.7_A	B-21	P1.6_A	C-21	P1.5_A
A-22	P1.2_A	B-22	P1.3_A	C-22	P1.4_A
A-23	P1.1_A	B-23	P1.0_A	C-23	N/C
A-24	C2D_A	B-24	N/C	C-24	N/C
A-25	/RST_A	B-25	GND	C-25	N/C
A-26	GND	B-26	N/C	C-26	N/C
A-27	N/C	B-27	N/C	C-27	N/C
A-28	N/C	B-28	N/C	C-28	N/C
A-29	VREF0	B-29	VDD_A	C-29	VREGIN_A
A-30	N/C	B-30	N/C	C-30	N/C
A-31	N/C	B-31	N/C	C-31	N/C
A-32	N/C	B-32	AGND	C-32	N/C

5.12. Potentiometer (J20)

The C8051F500 (Side A) device has the option to connect port pin P1.2 to 10K linear potentiometer. The potentiometer is connected through the J20 header. The potentiometer can be used for testing the analog-to-digital (ADC) converter of the MCU.

5.13. Power Supply I/O (Side A) (TB3)

All of the C8051F500 target device's supply pins are connected to the TB3 terminal block. Refer to Table 11 for the TB3 terminal block connections.

Table 11. TB1 Terminal Block Pin Descriptions

Pin #	Description
1	VIO_A
2	VREGIN_A
3	VDD_A
4	VDDA_A
5	GND_A
6	GND

5.14. C2 Pin Sharing

On the C8051F500 (Side A), the debug pin C2CK is shared with the /RST pin. On the C8051F502 (Side B), the debug pins C2CK and C2D are shared with the pins /RST and P3.0 respectively. The target board includes the resistors necessary to enable pin sharing which allow the pin-shared pins (/RST and P3.) to be used normally while simultaneously debugging the device. See Application Note "AN124: Pin Sharing Techniques for the C2 Interface" at www.silabs.com for more information regarding pin sharing.

C8051F50x/51x

5.15. Target Board Pin Assignment Summary

Some GPIO pins of the C8051F500 MCU can have an alternate fixed function. For example, pin 46 on the C8051F500 MCU is designated P0.4, and can be used as a GPIO pin. Also, if the UART0 peripheral on the MCU is enabled using the crossbar registers, the TX signal is routed to this pin. This is shown in the “Alternate Fixed Function” column. The “Target Board Function” column shows that this pin is used as TX on the ‘F500 Target Board. The “Relevant Headers” column shows that this signal is routed to pin 3 of the J17 header and pin 5 of the J1 header. More details can be found in the C8051F50x data sheet. Some of the GPIO pins of the C8051F500 have been used for various functions on the target board. All pins of the Side A MCU also connect to the 96-pin (P1) expansion connector which is not explicitly listed below. Table 12 summarizes the C8051F500 MCU pin assignments on the target board, and also shows the various headers associated with each signal.

Table 12. C8051F500 Target Board Pin Assignments and Headers

MCU Pin Name	Pin#	Primary Function	Alternate Fixed Function	Target Board Function	Relevant Headers
P0.0	8	P0.0	VREF	VREF	J1[1], J22[1]
P0.1	1	P0.1	CNVSTR	CNVSTR	J1[2]
P0.2	48	P0.2	XTAL1	XTAL1	J1[3]*, J9[1]
P0.3	47	P0.3	XTAL2	XTAL2	J1[4]*, J10[1]
P0.4	46	P0.4	UART_TX	TX_MCU	J1[5], J17[3]
P0.5	45	P0.5	UART_RX	RX_MCU	J1[6], J17[1]
P0.6	44	P0.6	CAN_TX	CNVSTR	J1[7], J17[5]
P0.7	43	P0.7	CAN_RX	SW2 (switch)	J1[8], J17[7]
P1.0	42	P1.0		LIN_TX	J2[1], J17[9]
P1.1	41	P1.1		LIN_RX	J2[2], J17[11]
P1.2	40	P1.2		POTENTIOMETER	J2[3], J20[1]
P1.3	39	P1.3		LED	J2[4], J19[3]
P1.4	38	P1.4		SWITCH	J2[5], J19[1]
P1.5	37	P1.5		GPIO	J2[6]
P1.6	36	P1.6		GPIO	J2[7]
P1.7	35	P1.7		GPIO	J2[8]
P2.0	34	P2.0		GPIO	J3[1]
P2.1	33	P2.1		GPIO	J3[2]
P2.2	32	P2.2		GPIO	J3[3]
P2.3	31	P2.3		GPIO	J3[4]
P2.4	30	P2.4		GPIO	J3[5]
P2.5	29	P2.5		GPIO	J3[6]
P2.6	28	P2.6		GPIO	J3[7]

Table 12. C8051F500 Target Board Pin Assignments and Headers (Continued)

MCU Pin Name	Pin#	Primary Function	Alternate Fixed Function	Target Board Function	Relevant Headers
P2.7	27	P2.7		GPIO	J3[8]
P3.0	26	P3.0		GPIO	J4[1]
P3.1	25	P3.1		GPIO	J4[2]
P3.2	24	P3.2		GPIO	J4[3]
P3.3	23	P3.3		GPIO	J4[4]
P3.4	22	P3.4		GPIO	J4[5]
P3.5	21	P3.5		GPIO	J4[6]
P3.6	20	P3.6		GPIO	J4[7]
P3.7	19	P3.7		GPIO	J4[8]
P4.0	18	P4.0		GPIO	J5[1]
P4.1	17	P4.1		GPIO	J5[2]
P4.2	16	P4.2		GPIO	J5[3]
P4.3	15	P4.3		GPIO	J5[4]
P4.4	14	P4.4		GPIO	J5[5]
P4.5	13	P4.5		GPIO	J5[6]
P4.6	10	P4.6		GPIO	J5[7]
P4.7	9	P4.7		GPIO	J5[8]
/RST/C2CK	12	/RST	C2CK	/RST/C2CK	P2[7], P2[5]*
C2D	11	C2D		C2D	P2[4]
VIO	2	VIO		VIO	J24[4], J18[1], TB3[1] J1-J5[9]
VREGIN	3	VREGIN		VREGIN	J24[2], P2[5]*, TB3[2]
VDD	4	VDD		VDD	TB3[3]
VDDA	5	VDDA		VDDA	TB3[4]
GND	6	GND		GND	J1-J5[10], TB3[6]
GND A	7	GND A		VDD	TB3[5]

***Note:** Headers denoted by this symbol are not directly connected to the MCU pin; the connection might be via one or more headers and/or pin-sharing resistor(s). See board schematic for details.

6. Schematics

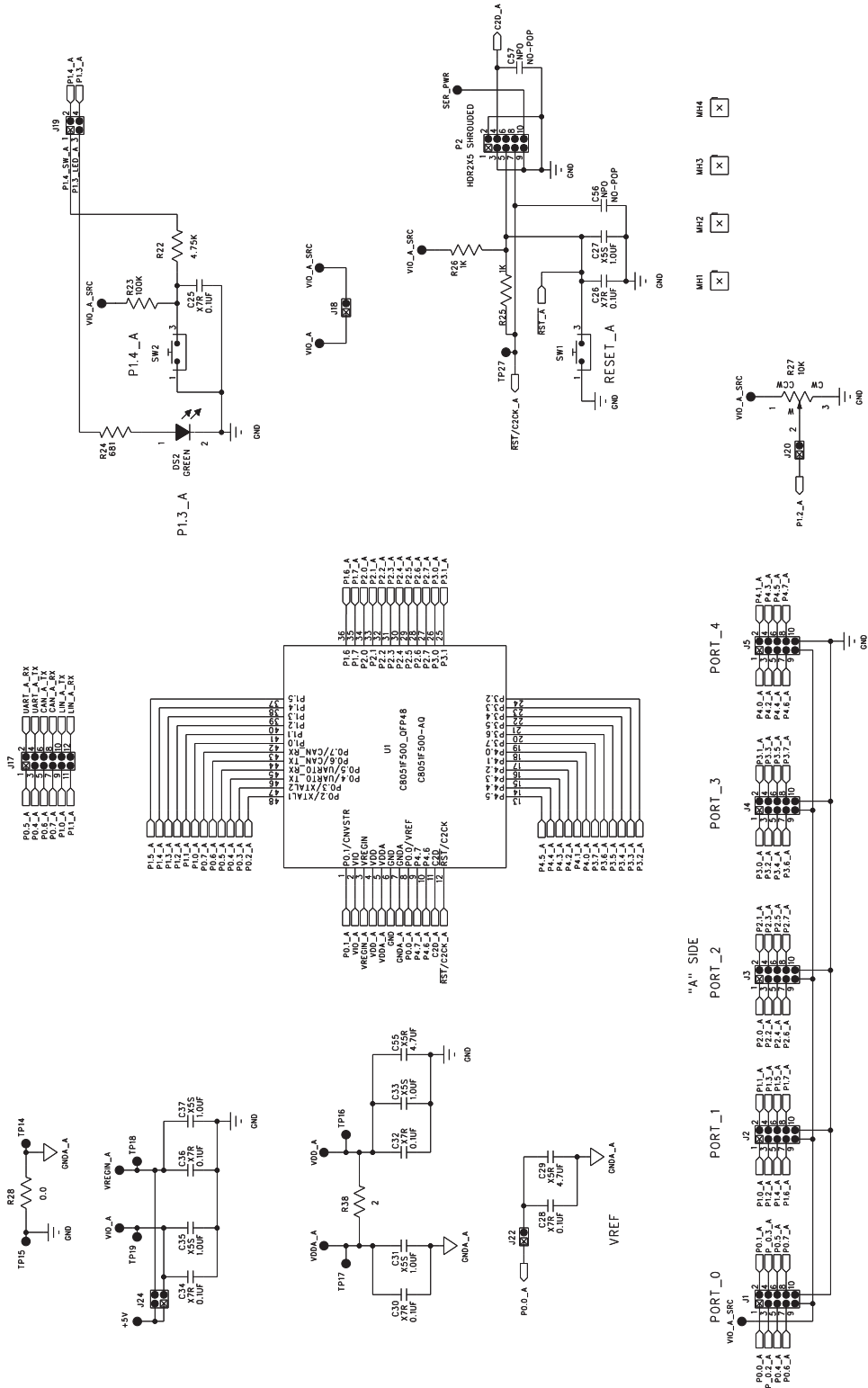

Figure 6. C8051F502 Target Board Schematic (Page 1 of 4)

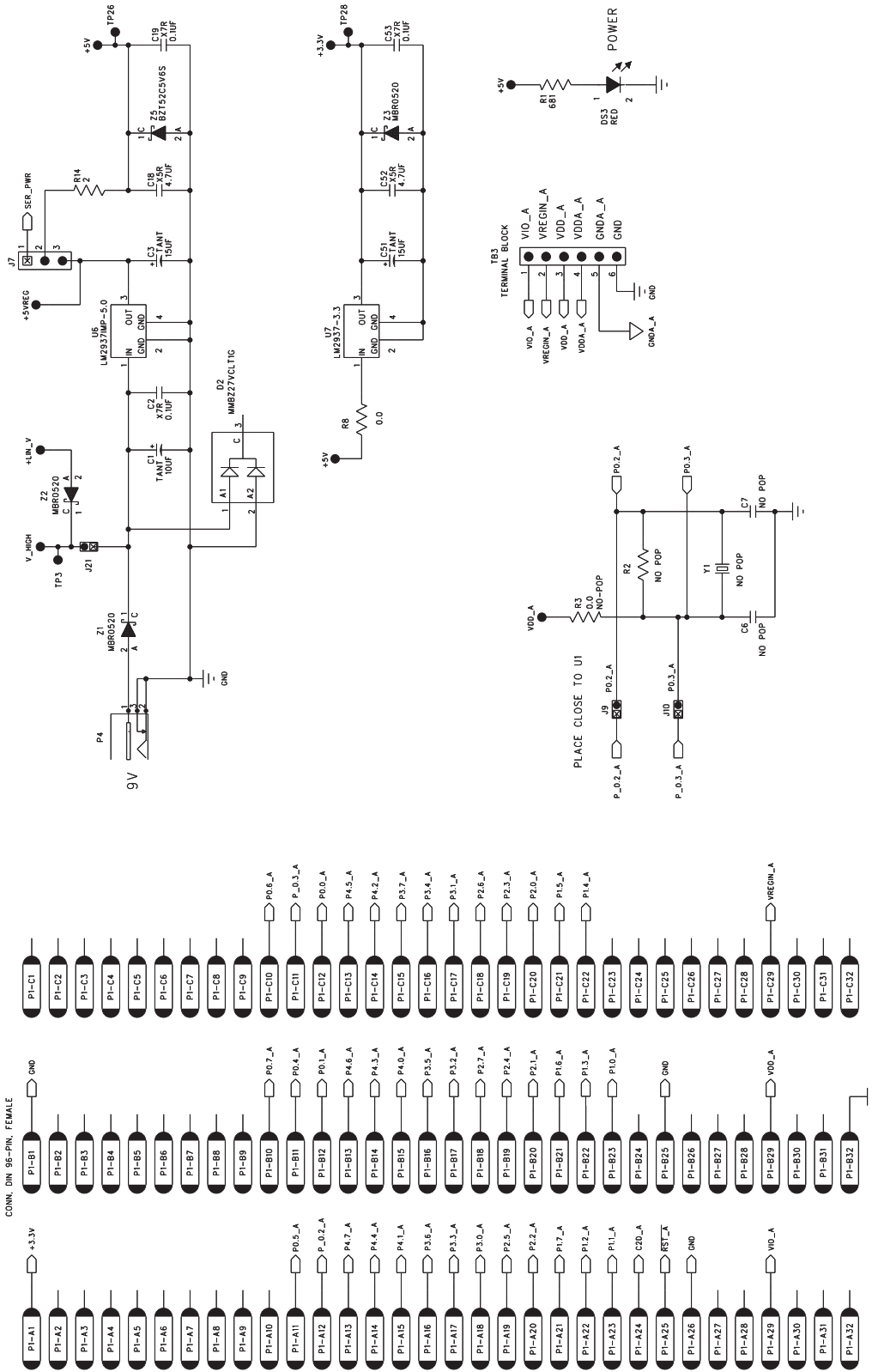

Figure 7. C8051F502 Target Board Schematic (Page 2 of 4)

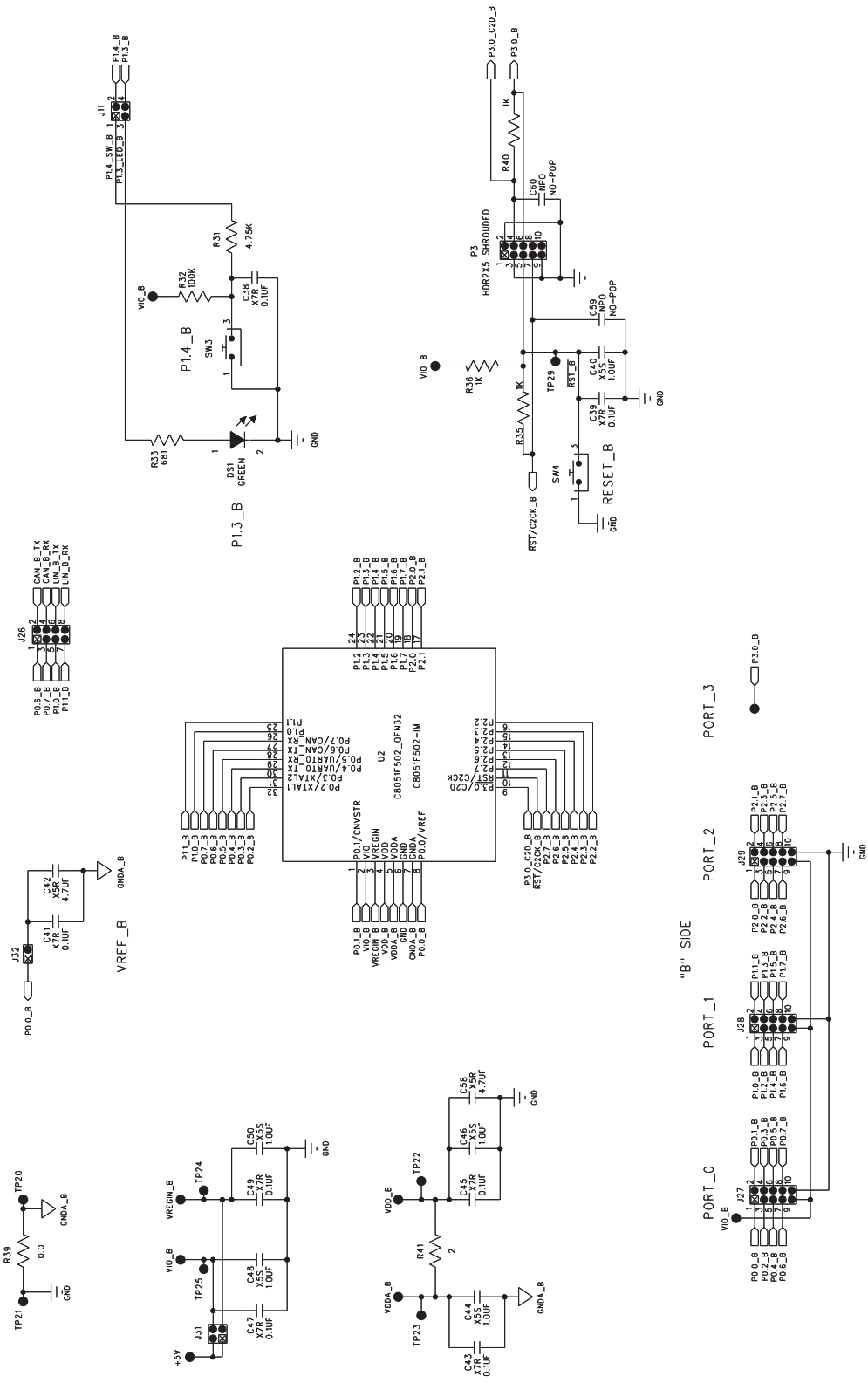

Figure 8. C8051F502 Target Board Schematic (Page 3 of 4)

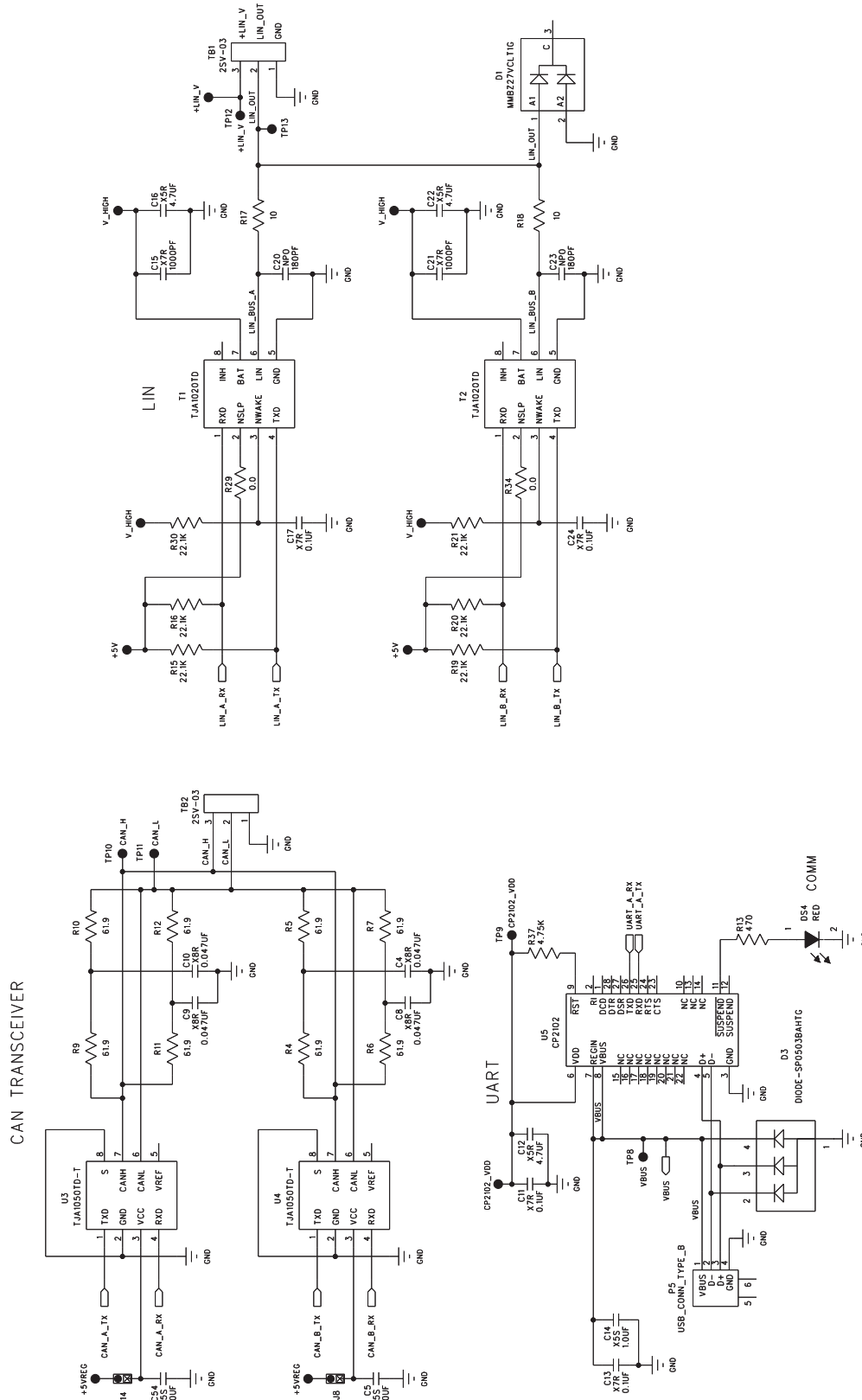

Figure 9. C8051F502 Target Board Schematic (Page 4 of 4)

DOCUMENT CHANGE LIST

Revision 0.1 to Revision 0.2

- Updated 4. "Software Setup," on page 2.

CONTACT INFORMATION

Silicon Laboratories Inc.

400 West Cesar Chavez

Austin, TX 78701

Tel: 1+(512) 416-8500

Fax: 1+(512) 416-9669

Toll Free: 1+(877) 444-3032

Please visit the Silicon Labs Technical Support web page:

<https://www.siliconlabs.com/support/pages/contacttechnicalsupport.aspx>

and register to submit a technical support request.

Patent Notice

Silicon Labs invests in research and development to help our customers differentiate in the market with innovative low-power, small size, analog-intensive mixed-signal solutions. Silicon Labs' extensive patent portfolio is a testament to our unique approach and world-class engineering team.

The information in this document is believed to be accurate in all respects at the time of publication but is subject to change without notice. Silicon Laboratories assumes no responsibility for errors and omissions, and disclaims responsibility for any consequences resulting from the use of information included herein. Additionally, Silicon Laboratories assumes no responsibility for the functioning of undescribed features or parameters. Silicon Laboratories reserves the right to make changes without further notice. Silicon Laboratories makes no warranty, representation or guarantee regarding the suitability of its products for any particular purpose, nor does Silicon Laboratories assume any liability arising out of the application or use of any product or circuit, and specifically disclaims any and all liability, including without limitation consequential or incidental damages. Silicon Laboratories products are not designed, intended, or authorized for use in applications intended to support or sustain life, or for any other application in which the failure of the Silicon Laboratories product could create a situation where personal injury or death may occur. Should Buyer purchase or use Silicon Laboratories products for any such unintended or unauthorized application, Buyer shall indemnify and hold Silicon Laboratories harmless against all claims and damages.

Silicon Laboratories and Silicon Labs are trademarks of Silicon Laboratories Inc.

Other products or brandnames mentioned herein are trademarks or registered trademarks of their respective holders.