



CONTENTS	PAGE
<b><i>har-mik</i></b> ® connector system – introduction	06.02
<b><i>I/O connectors</i></b>	06.04
Pin and socket	
Technical characteristics	06.06
Connectors with straight pins	06.07
Connectors with right angled solder pins	06.09
Connectors with IDC flat cable termination	06.11
Connectors with IDC discrete wire termination	06.12
Bellows	
Technical characteristics	06.14
Connectors with straight solder pins	06.15
Connectors with right angled pins	06.16
Connectors with IDC discrete wire termination	06.18
Hoods	
Technical characteristics	06.20
Hoods for pin and socket male connectors	06.21
Hoods for bellows male connectors	06.23
Accessories	06.24
<b><i>Intra cabinet connectors</i></b>	06.25
Pin and socket	
Technical characteristics	06.26
Connectors with straight pins	06.27
Connectors with IDC flat cable termination	06.28
<b><i>Cables and cable assemblies</i></b>	06.29

Tooling see chapter 20

### *har-mik*® interface connectors in 1.27 mm pitch

Miniature D connectors are a must in various cable-to-board applications where space saving and high data transfer rates are required. For the purposes of miniaturization and speed, HARTING offers a wide range of miniature D connectors with 14 to 100 poles.

Available in two contact styles (pin & socket and bellows), these connectors in 1.27 mm contact pitch allow data transfer rates up to 600 MHz. The *har-mik*® connectors comply with various standards such as SCSI, IPI, HIPPI, EIA/TIA, IEC, IEEE 1284.

There are the following components available in this range:

- Straight or right angled shielded and unshielded board connectors with latch or screw fixing for standard wave soldering. The *har-mik*® connectors are suitable for press-in and SMC and are designed for pick and place assembly.
- IDC cable connectors for round discrete wire cables and flat cables.
- Metal and plastic hoods with top and side cable entry (also for cables with large diameter) for all *har-mik*® sizes.
- Flat and round cables for harnesses and screw locks for panel mounting.
- All necessary tooling for insulation displacement termination.

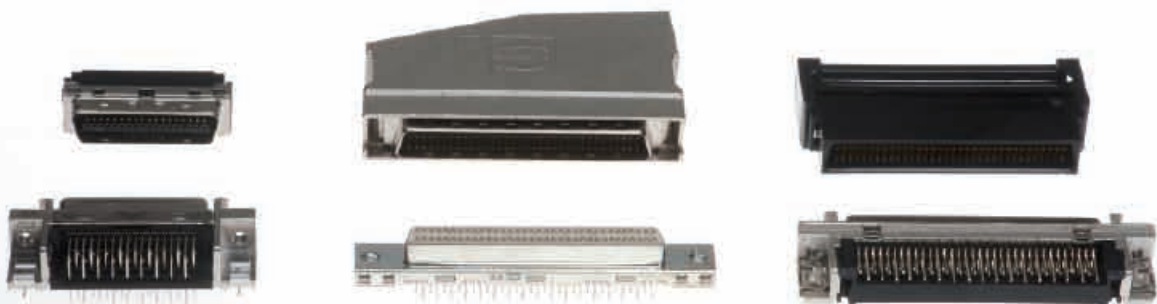

Space saving connectors in 1.27 mm pitch



IDC cable connectors for round discrete wire cables and flat cables

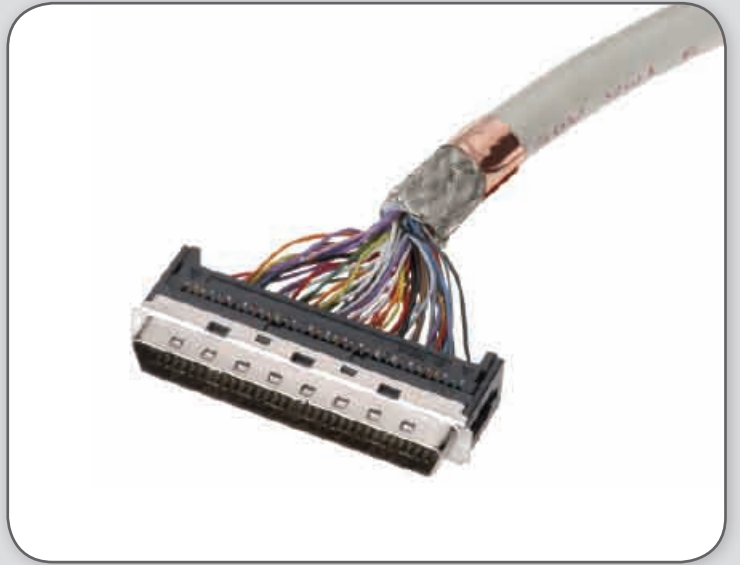

Two contact styles

- Pin and socket
- Bellows

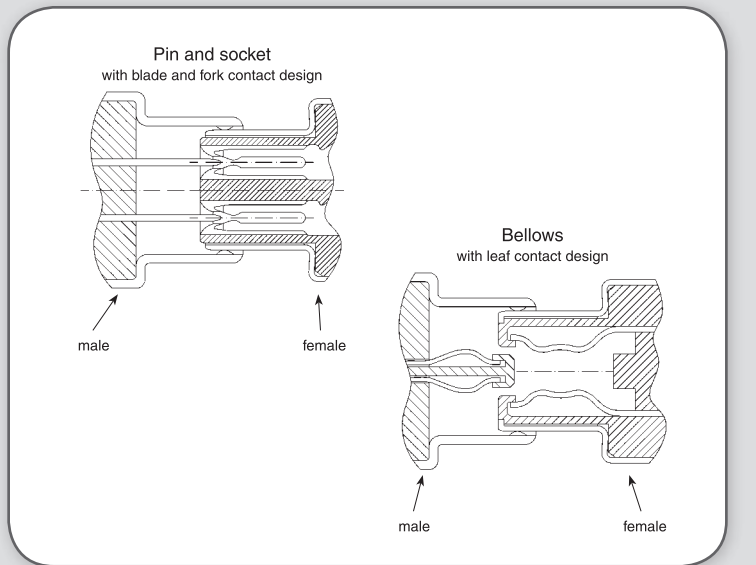

## for economical and reliable connections

A comprehensive range of high density interface connectors based on two mating design concepts:

- Blade and fork contact in the Pin/Socket range.
- Leaf contact in the Bellows range.

Available in a various number of contacts with options for secure locking of mated connectors in accordance with the following international standards:

- Small Computer System Interface  
SCSI-2  
SCSI-2 wide  
SCSI-3
- Intelligent Peripheral Interface  
IPI
- High Performance Peripheral Interface  
HIPPI
- High Speed Serial Interface  
HSSI
- Media Independent Interface  
MII
- Bi-directional Parallel Interface  
IEEE – 1284-C
- EIA – TIA  
232-E
- IEC  
61 076-3-100  
for bellows connectors
- IEC  
61 076-3-101  
for pin and socket connectors

UL recognised

For customer specific applications we can design and manufacture solutions to match your requirement.

Sales department  
HARTING components



Certified according to EN ISO 9001 in design/development, production, installation and servicing

**Bellows**  
with leaf contact design

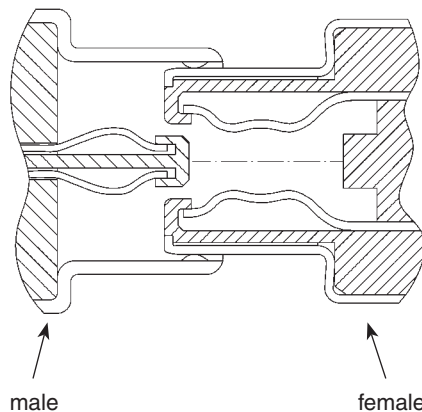

**Pin and socket**  
with blade and fork contact design

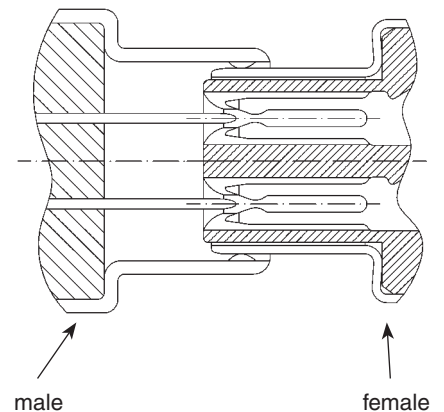





Number of contacts

# 20–68

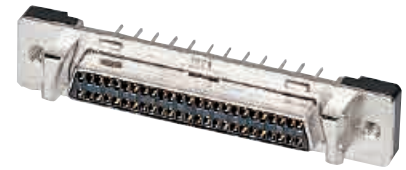

Female connectors, straight

Identification	No. of contacts	Part No.
Female connectors with straight solder pins	20	60 01 020 5102
	26	60 01 026 5102
	50	60 01 050 5102
	68	60 01 068 5102

Dimensions

	a	b <sub>±0.1</sub>	c	e	f	g	h
20	33.40	27.43	15.60	9 x 1.27 = 11.43	23.24	23.70	27.45
26	37.21	31.24	19.41	12 x 1.27 = 15.24	27.05	27.50	31.25
50	52.45	46.48	34.65	24 x 1.27 = 30.48	42.29	42.80	46.50
68	63.88	57.91	46.08	33 x 1.27 = 41.91	53.72	54.20	57.90

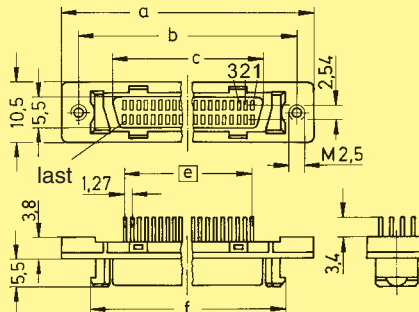

Board drillings

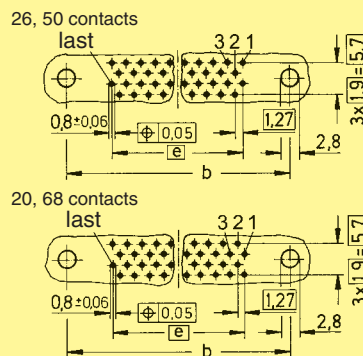

Panel cut out

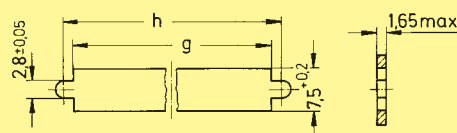

Dimensions in mm

Number of contacts

# 68

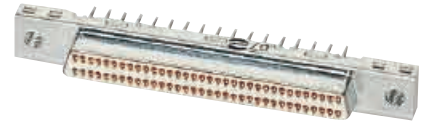

Female connectors, straight

Identification	No. of contacts	Part No.
SMC female connector with straight solder pins	68	60 02 068 5120
Female connector with straight press-in pins	68	60 02 068 5322

Dimensions

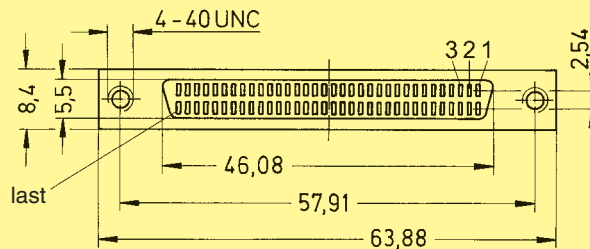
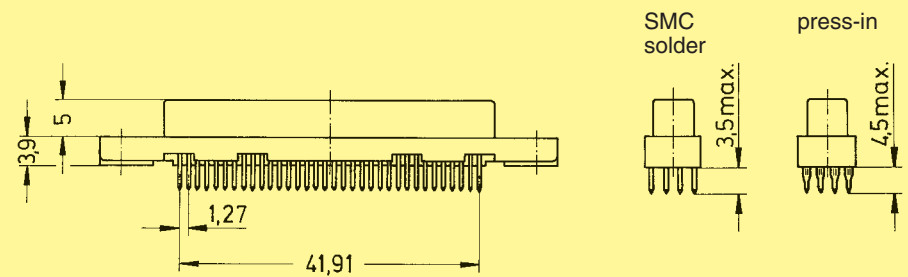

Board drillings  
(Components side)

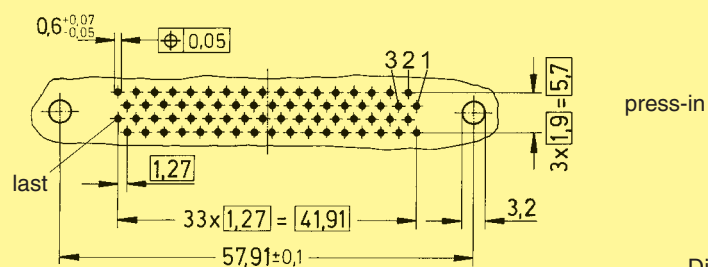
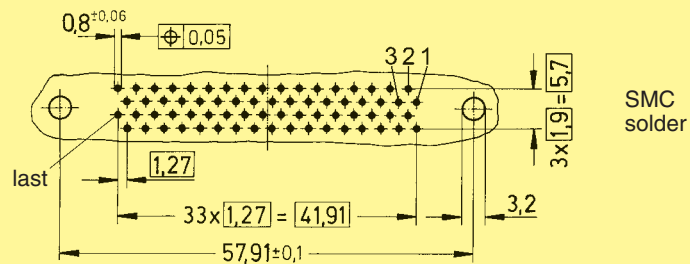

Dimensions in mm

Number of contacts

# 20–68

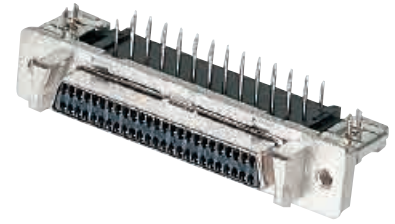

Female connectors, angled

Identification	No. of contacts	Part No.
Female connectors with angled solder pins	20	60 01 020 51 ...
	26	60 01 026 51 ...
	50	60 01 050 51 ...
	68	60 01 068 51 ...
Panel fixing	Board fixing	
M 2.5	M 2.5	32
M 2.5	Board lock	40

### Dimensions

	a	b <sub>±0.1</sub>	c	e	f	g	h
20	33.40	27.40	15.60	9 x 1.27 = 11.43	23.24	23.70	27.45
26	37.21	31.24	19.41	12 x 1.27 = 15.24	27.05	27.50	31.25
50	52.45	46.45	34.65	24 x 1.27 = 30.48	42.29	42.80	46.50
68	63.88	57.88	46.08	33 x 1.27 = 41.91	53.72	54.20	57.90

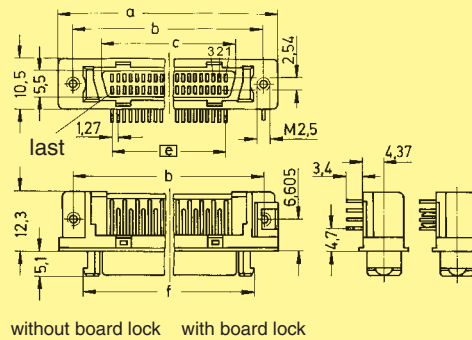

### Board drillings

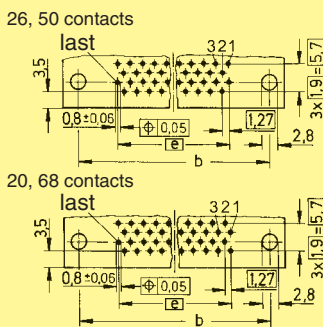

### Panel cut out

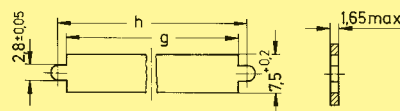

Dimensions in mm

Number of contacts

# 68-100

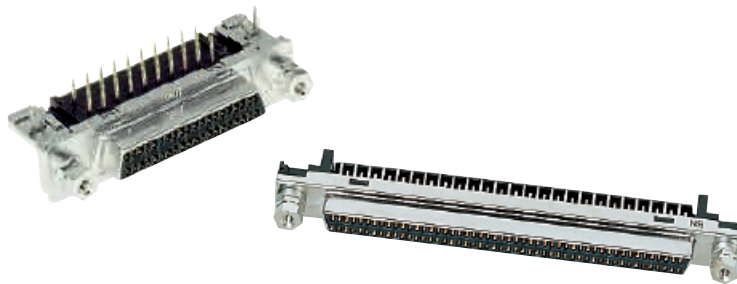

Female connectors, angled

Identification	No. of contacts	Part No.
Female connectors with angled solder pins	68	60 02 068 51 ...
	100	60 02 100 51 ...
With female screw lock	41	
Without female screw lock	50	

## Dimensions

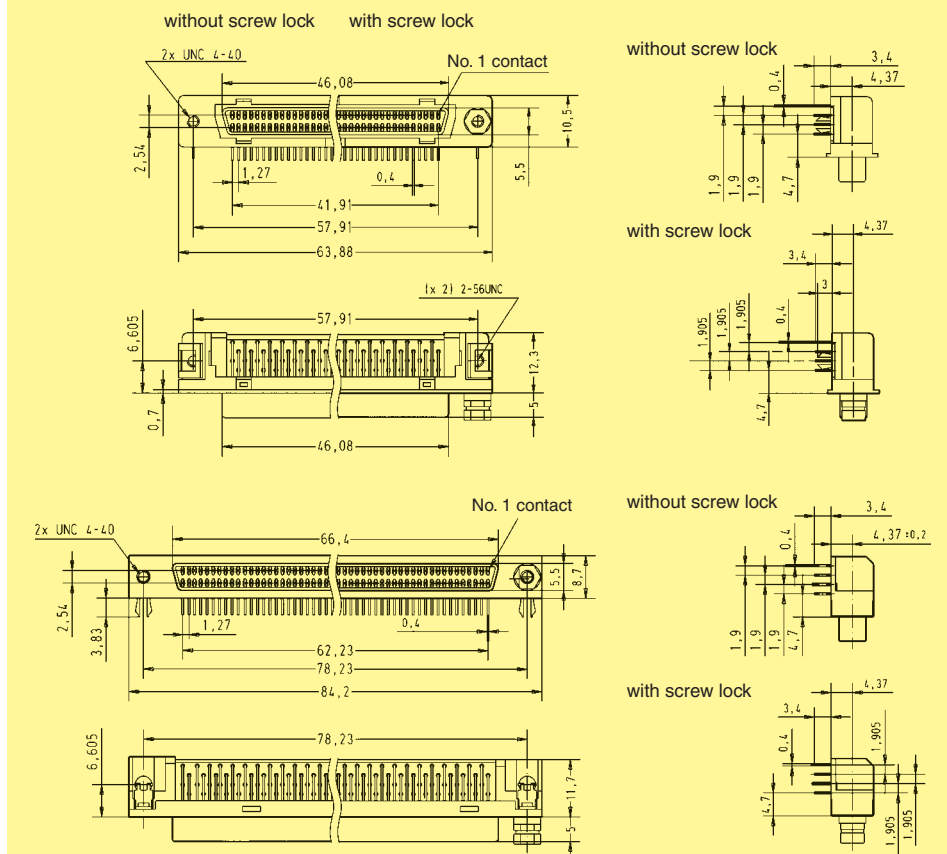

## Board drillings

(Components side)

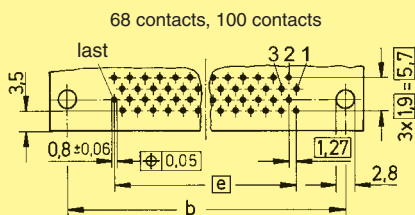

	a <sub>1</sub>	b	e
68	54.22	57.91	33 x 1.27 = 41.91
100	74.53	78.23	49 x 1.27 = 62.23

## Panel cut out

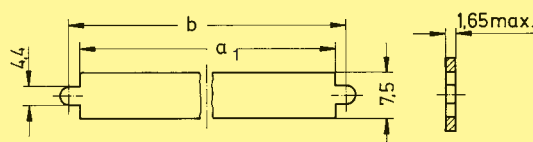

Dimensions in mm

harmik

Number of contacts

# 50–68

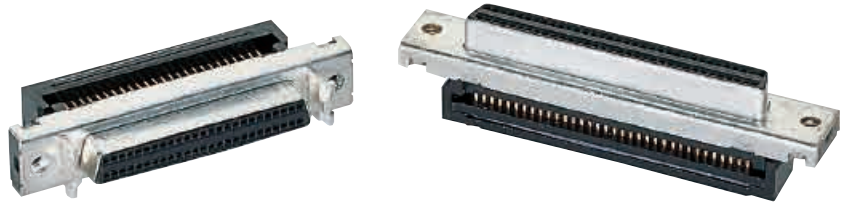

Female connectors for IDC flat cable, straight

Identification	No. of contacts	Part No.	
		with latch system	with screw lock system
Female panel connectors with insulation displacement termination for IDC flat cable pitch 0.635 mm AWG 30	50	60 04 050 5343	60 04 050 5344
	68	60 04 068 5343	60 04 068 5344

Dimensions for connectors with latch system

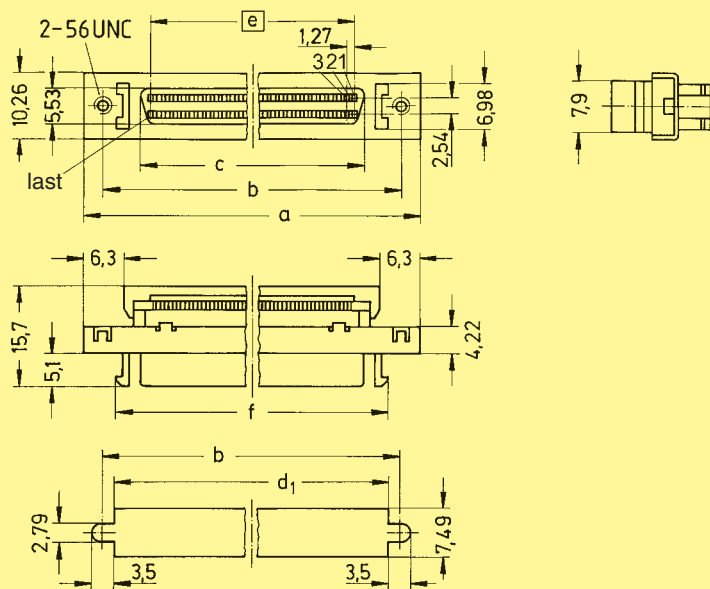

Panel cut out

	a	b	c	d <sub>1</sub>	d <sub>2</sub>	e	f
50	52.45	46.48	34.70	42.80	42.30	30.48	42.30
68	63.88	57.91	46.13	54.23	53.72	41.91	53.72

Dimensions for connectors with screw lock system

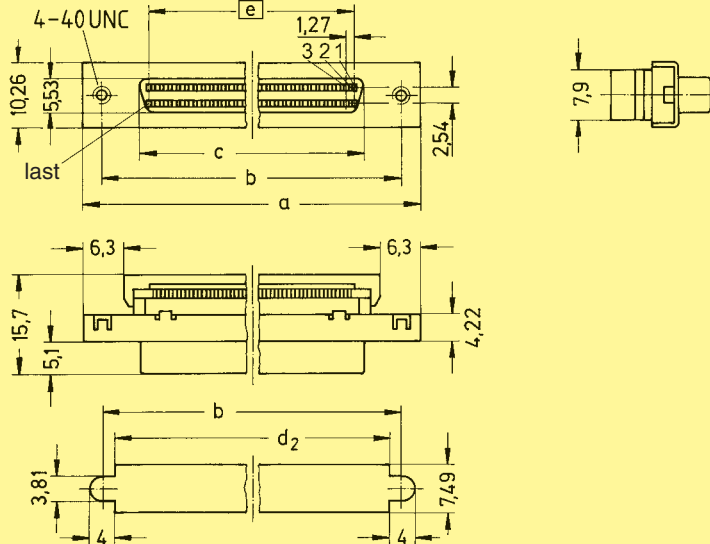

Panel cut out

Dimensions in mm

Number of contacts

# 20–100

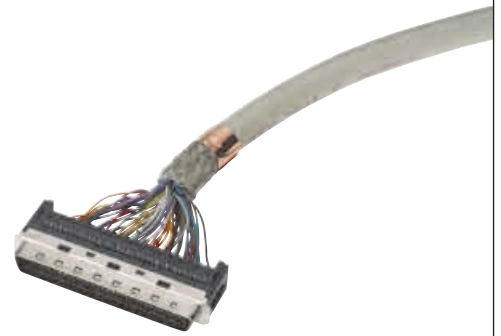

Male connectors for IDC discrete wire, straight

Identification	No. of contacts	Part No.
Male connectors with insulation displacement termination for discrete wire AWG 28/30	20	60 03 020 52 ...
	26	60 03 026 52 ...
	50	60 03 050 52 ...
	68	60 03 068 52 ...
	100	60 03 100 52 ...
Insulation diameter (mm)	∅ = 0.50–0.65	00
	∅ = 0.65–0.80	10
	∅ = 0.80–0.88	20

### Available sizes

	Part No.	∅	20	26	50	68	100
Male	60 03 ... 5200	0.50–0.65	●	●	●	●	
	60 03 ... 5210	0.65–0.80	●		●	●	●
	60 03 ... 5220	0.80–0.88	●	●	●		

● = Available sizes



A manual for the har-mik® connector and cable assembly is available in our online catalogue *HARKIS*® or on demand at your local HARTING representative.

### Dimensions

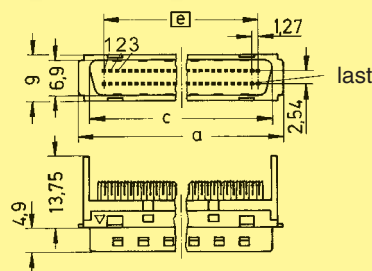

	a	c	d	e
20	21.25	17.00	16.75	11.43
26	25.06	20.81	20.56	15.24
50	40.30	36.05	35.80	30.48
68	51.73	47.48	47.23	41.91
100	72.05	67.80	67.55	62.23

### Comb cover

(delivered with connectors)

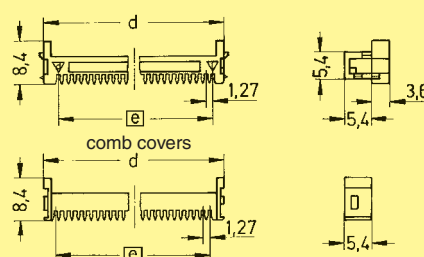

Dimensions in mm





Number of contacts

# 26–68



Male and female connectors, straight

Identification	No. of contacts	Part No.	
		Male connector	Female connector
Male and female connectors with straight solder pins	26		60 11 026 5102
	36	60 11 036 5202	60 11 036 5102
	50	60 11 050 5202	60 11 050 5102
	68		60 11 068 5102

Dimensions for male connectors

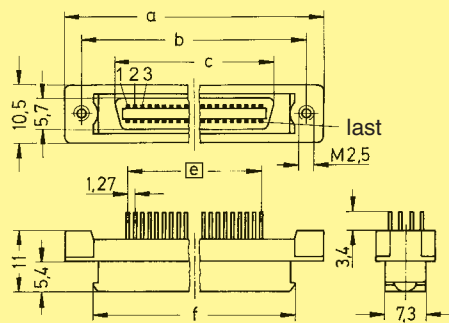

Board drillings

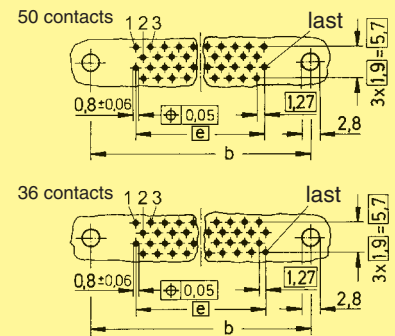

	a	b <sub>±0.1</sub>	c	e	f	g	h
26	37.16	31.26	20.26	12 x 1.27 = 15.24	27.11	27.50	31.25
36	43.51	37.61	26.61	17 x 1.27 = 21.59	33.46	33.90	37.60
50	52.40	46.50	35.50	24 x 1.27 = 30.48	42.35	42.80	46.50
68	63.83	57.93	46.93	33 x 1.27 = 41.91	53.78	54.20	57.90

Dimensions for female connectors

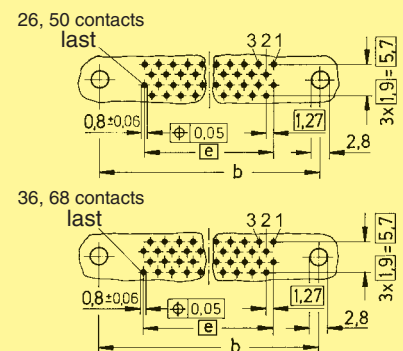
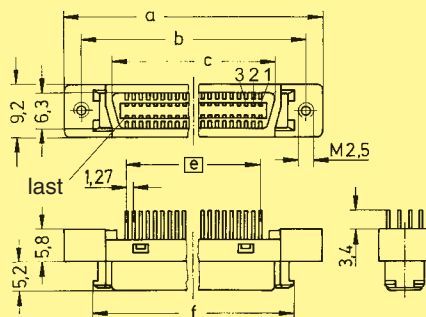

Panel cut out

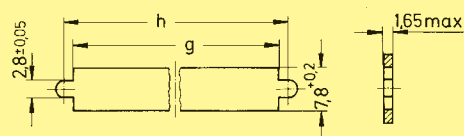

Dimensions in mm

har-mik

Number of contacts

# 20-68

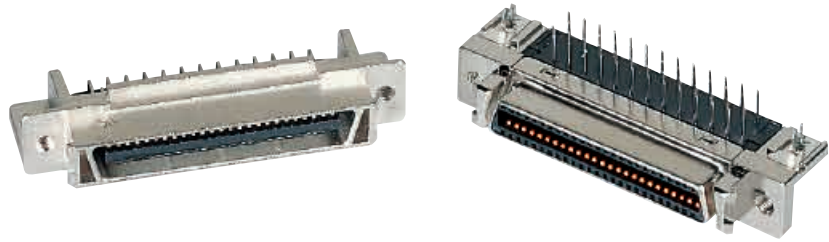

Male and female connectors, angled

Identification	No. of contacts	Part No.	
Male and female connectors with angled solder pins		Male connector	Female connector
	20		60 11 020 51 ...
	26		60 11 026 51 ...
	28	60 11 028 5232	
	36	60 11 036 5232	60 11 036 51 ...
	50	60 11 050 5232	60 11 050 51 ...
	68	60 11 068 5232	60 11 068 51 ...
Without board lock	32		
With board lock	40		

Dimensions for male connectors

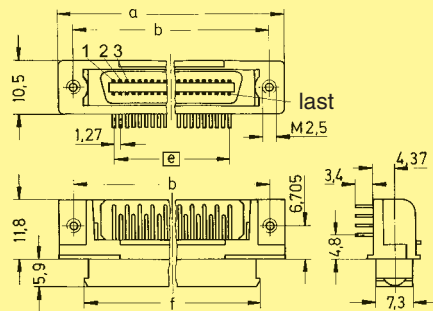

	a	b <sub>±0.1</sub>	c	e	f	g	h
20	33.40	27.40	16.45	9 x 1.27 = 11.43	23.30	23.70	27.45
26	37.16	31.26	20.26	12 x 1.27 = 15.24	27.11	27.50	31.25
28	38.48	32.48	—	13 x 1.27 = 16.51	28.38	28.80	32.50
36	43.56	37.56	26.61	17 x 1.27 = 21.59	33.46	33.90	37.60
50	52.45	46.45	35.50	24 x 1.27 = 30.48	42.35	42.80	46.50
68	63.88	57.88	46.93	33 x 1.27 = 41.91	53.78	54.20	57.90

Board drillings

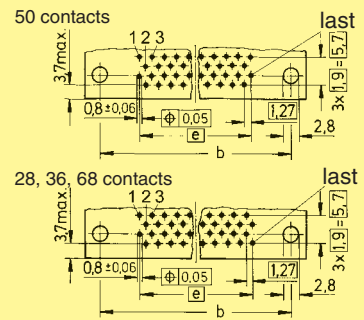

Dimensions for female connectors

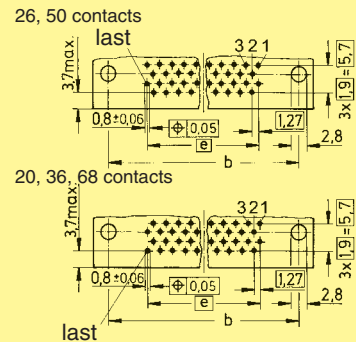
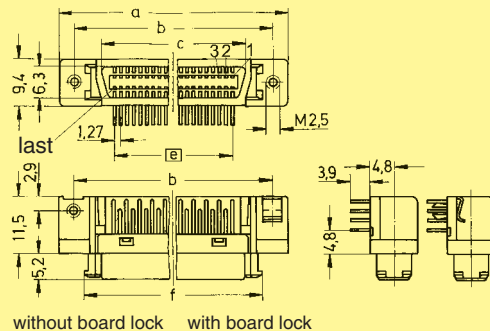

Panel cut out

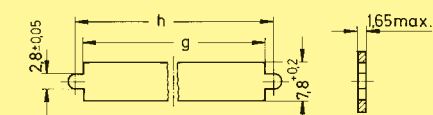

Dimensions in mm



Number of contacts

# 20–68



Male connectors for IDC discrete wire, straight

Identification	No. of contacts	Part No.
Male connectors with insulation displacement termination for discrete wire AWG 28/30 Insulation diameter (mm) Ø = 0.50–0.65		Male connector
	20	60 13 020 5200
	26	60 13 026 5200
	36	60 13 036 5200
	50	60 13 050 5200
	68	60 13 068 5200

Dimensions for male connectors

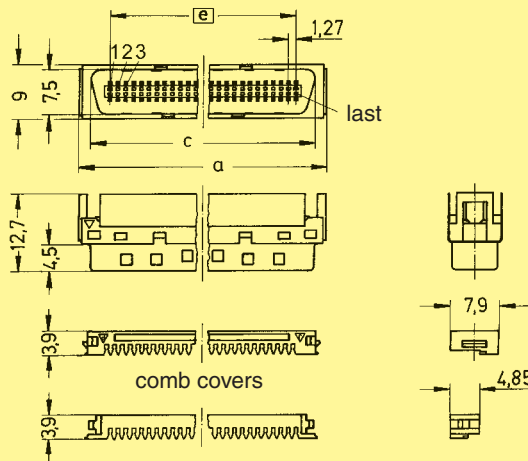

	a	c	e
20	21.24	17.55	11.43
26	25.05	21.36	15.24
36	31.40	27.71	21.59
50	40.29	36.60	30.48
68	51.72	48.03	41.91



A manual for the har-mik<sup>®</sup> connector and cable assembly is available in our online catalogue *HARKIS*<sup>®</sup> or on demand at your local HARTING representative.



Hoods for pin and socket male connectors

Number of contacts	20, 26, 36, 50, 68, 100
Surface	Die cast zamac, nickel-plated
	Thermoplastic resin, nickel-plated, steel insert

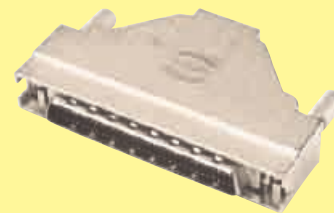
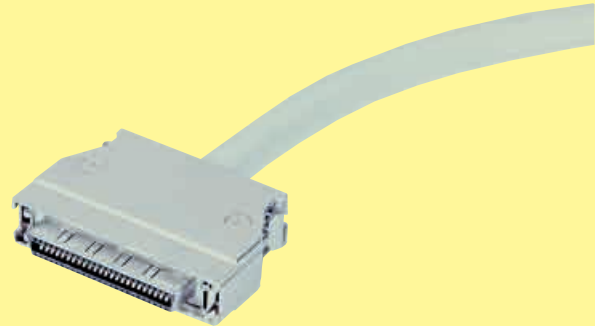

Hoods for bellows male connectors

Number of contacts	20, 26, 36, 50, 68
Surface	Die cast zamac, nickel-plated
	Thermoplastic resin, nickel-plated, steel insert

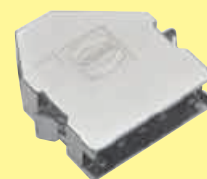

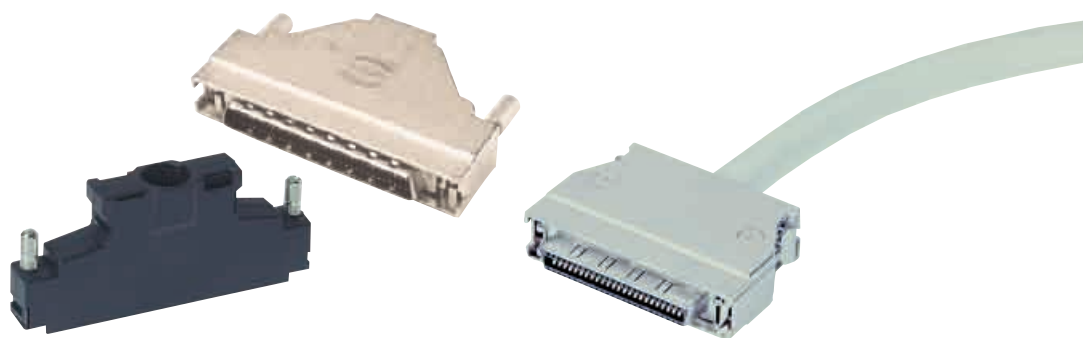

Top entry hoods

Identification      No. of contacts      Part No.      Drawing      Dimensions in mm

**Metal hood**  
Large cable entry

20      60 03 020 0255  
26      60 03 026 0255  
36      60 03 036 0255  
50      60 03 050 0255  
68      60 03 068 0255

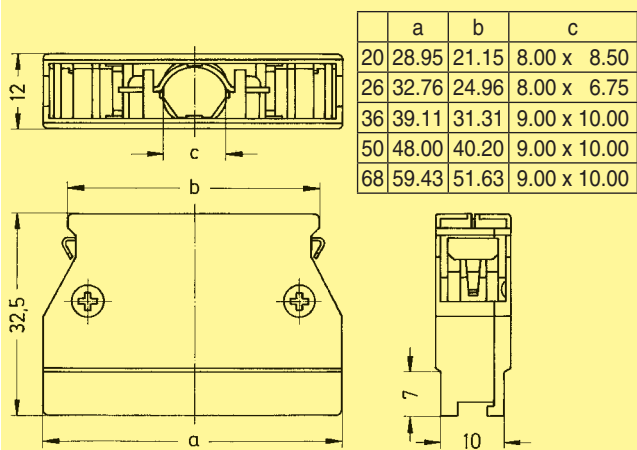

**Metal hood**  
Top cable entry

68      60 03 068 0145

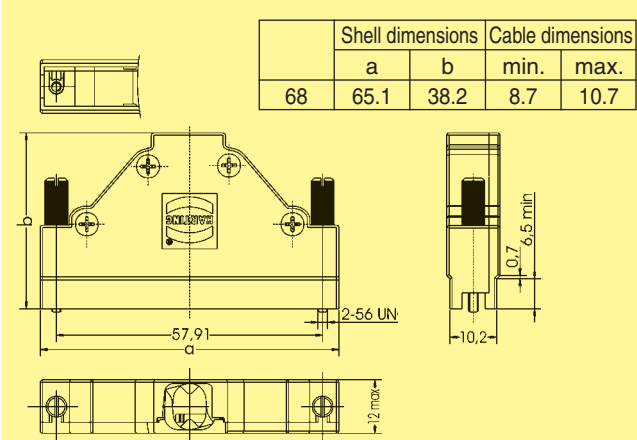

**Plastic hood**  
with internal screen<sup>1)</sup>

50      60 03 050 0143  
68      60 03 068 0143  
100      60 03 100 0143

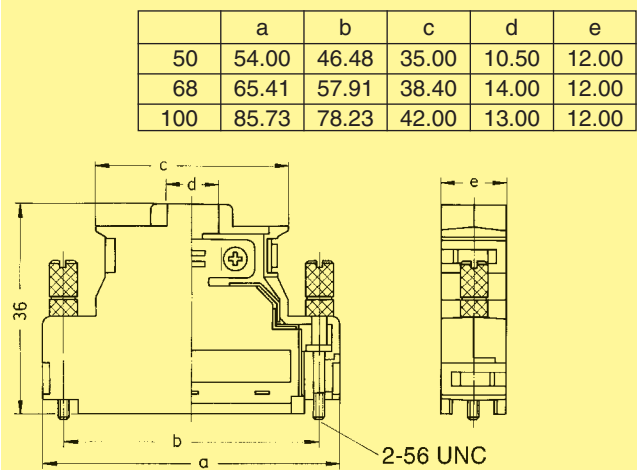

For other size, please consult us.  
<sup>1)</sup> Temperature range: - 55 °C ... + 60 °C

hartmik





Top or side entry hoods

Identification	No. of contacts	Part No.	Drawing	Dimensions in mm
----------------	-----------------	----------	---------	------------------

Plastic hood with internal screen<sup>1)</sup>

20	60 13 020 0153
26	60 13 026 0153
36	60 13 036 0153
50	60 13 050 0153
68	60 13 068 0153

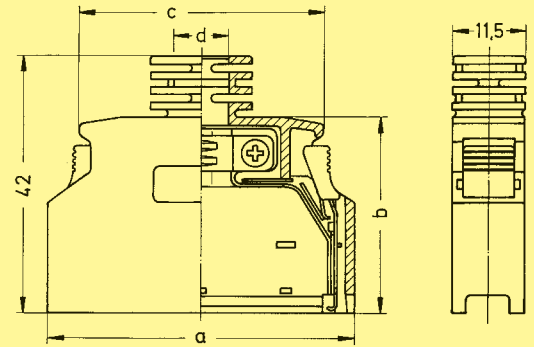

	a	b	c	d
20	29.65	34.50	19.95	6.80
26	33.46	38.31	23.76	7.10
36	39.81	32.00	30.11	8.20
50	48.70	32.00	39.00	8.70
68	60.13	32.00	50.43	9.10

Metal hood  
Cable side entry

26	60 13 026 0555
----	----------------

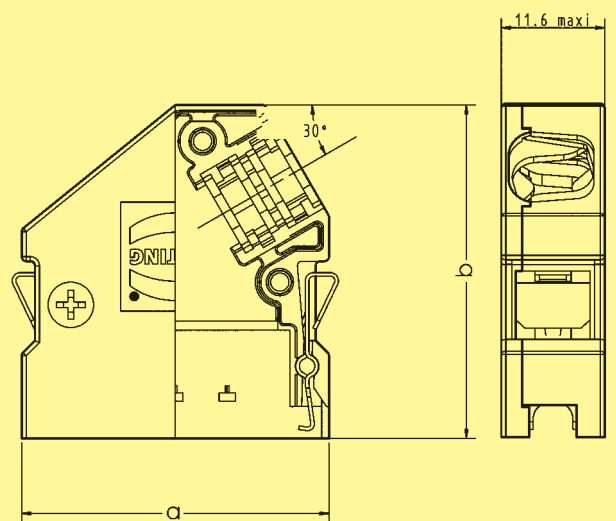

	Shell dimensions		Cable dimensions	
	a	b	min.	max.
26	33.8	36.8	6.5	8.5

<sup>1)</sup> Temperature range: - 55 °C ... + 60 °C



## for economical and reliable connections

A comprehensive range of high density intra cabinet connectors based on blade and fork contacts.

Available in a various number of contacts according to the following international standards and applications:

- Small Computer System Interface  
SCSI-2  
SCSI-2 wide  
SCSI-3
  
- Internal Bus extension through  
“Daisy chain” inter-linking via  
0.635 mm pitch flat cable.  
The 4-point design of the IDC  
contact provides accurate and  
reliable termination even with  
teflon cable.

UL recognised

For customer specific applications we can design and manufacture solutions to match your requirement.

Sales department  
HARTING components



Certified according to EN ISO 9001  
in design/development, production,  
installation and servicing

Pitch	1.27 mm
<b>Working current</b>	
pcb connector	1 A
Flat cable connector	0.5 A
<b>Working voltage</b>	
pcb connector	240 V ~
Flat cable connector	100 V ~
<b>Test voltage U<sub>r.m.s.</sub></b>	
pcb connector	750 V
Flat cable connector	500 V
Contact resistance	≤ 25 mΩ
Insulation resistance	≥ 10 <sup>3</sup> MΩ
<b>Temperature range</b>	
during SMC reflow soldering	-55 °C ... + 105 °C max. 240 °C for 60 s
<b>Terminations</b>	
Solder pins	Straight for pcb holes min. Ø 0.74 mm
Insulation displacement	Flat cable AWG 30 pitch 0.635 mm
<b>Materials</b>	
Moulding	Thermoplastic resin glass-fibre filled UL 94-V0
Contacts	
pcb connector	Copper alloy
Flat cable connector	Nickel
<b>Contact surface</b>	
Contact zone	Selectively gold plated according to performance level

<b>Press-in versions</b>	
Insertion process	Flat rock
Maximum press-in force per contact	100 N
Minimum push out force per contact	15 N
Number of repairs	2
Diameter of pcb plated through holes	Ø 0.6 <sup>+0.07</sup> <sub>-0.05</sub> mm
Recommended pcb holes for press-in process	Hole : Ø 0.71 – 0.74 mm Cu : 30 – 60 µm Sn : 5 – 20 µm
Pcb thickness	1.6 – 3.2 mm

Number of contacts

68

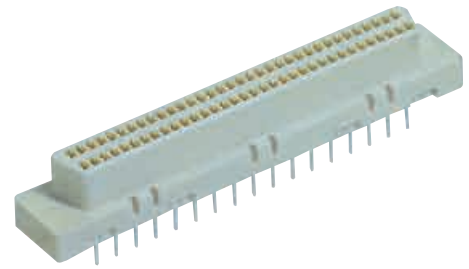

Connectors with straight pins

Identification	No. of contacts	Part No.
SMC female connector with straight solder pins	68	60 05 068 5100
Female connector with straight press-in pins	68	60 05 068 5322

Dimensions

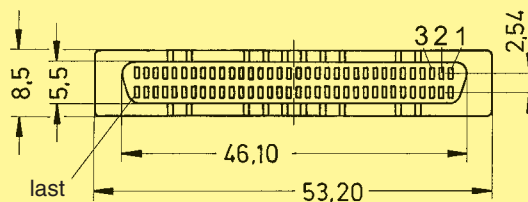
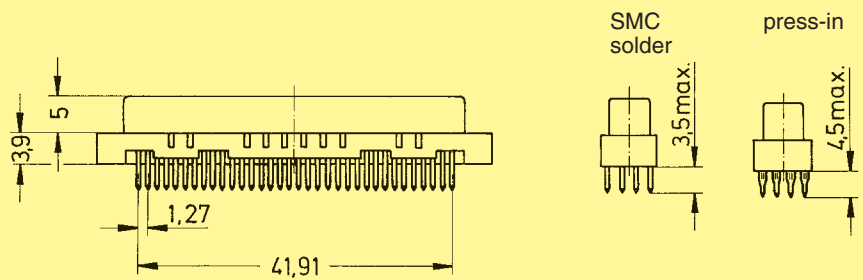

Board drillings  
(Components side)

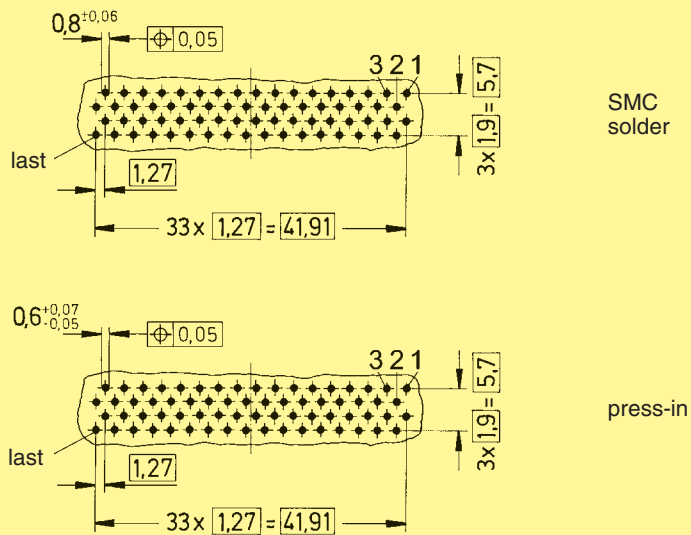

Dimensions in mm

har-mik

Number of contacts

# 50–68

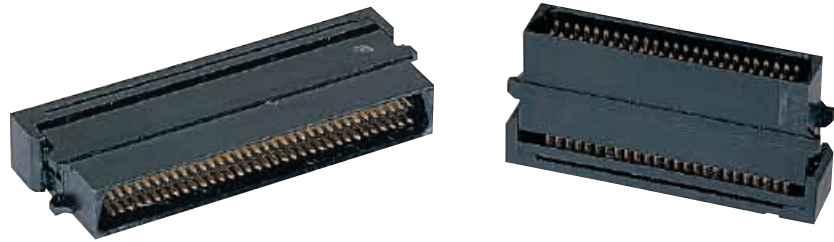

Connectors with IDC termination

Identification	No. of contacts	Part No.
Male connectors with insulation displacement termination for IDC flat cable pitch 0.635 mm AWG 30 Strain relief order separately		Male connector
	50	60 06 050 5440
	68	60 06 068 5440
		Strain relief
		60 06 050 9001
		60 06 068 9001

### Dimensions

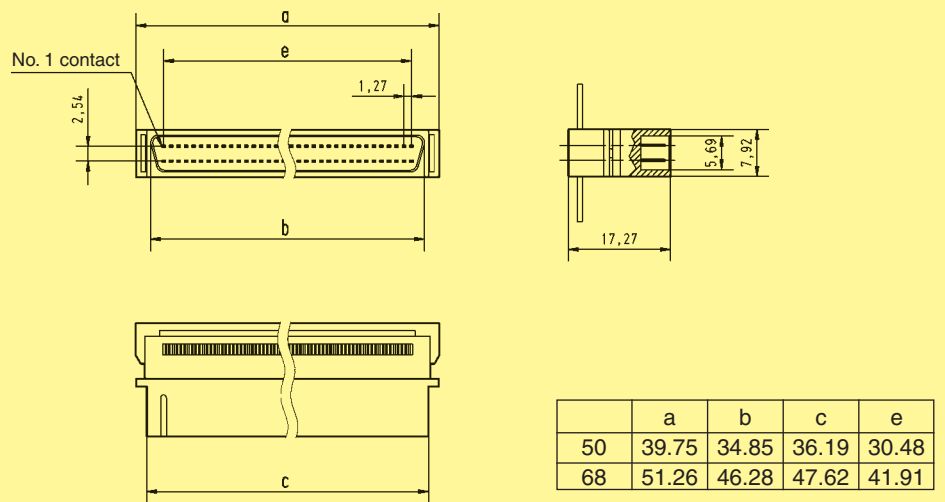

### Strain relief

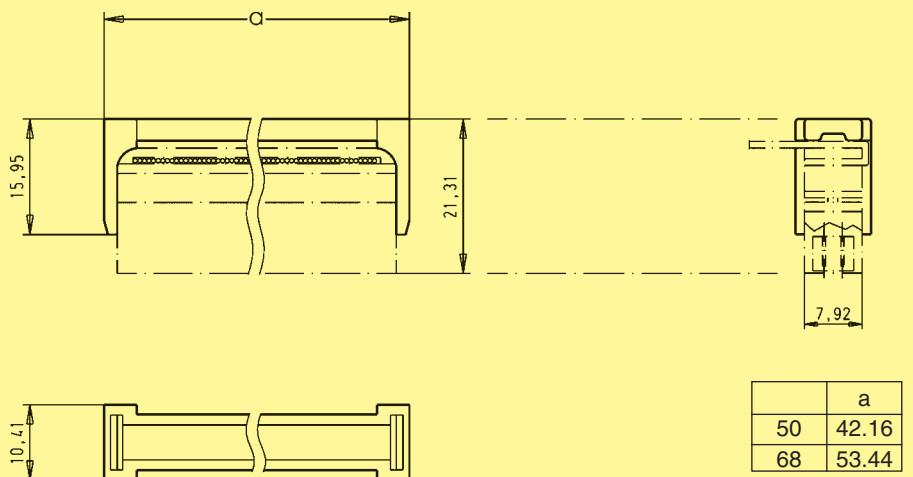

harmik



## Cables for insulation displacement termination

Identification	No. of pairs	Part No.
Twisted pair cable with braid shield AWG 28 Length per reel: 100 m*	5	60 90 005 6003
	10	60 90 010 6003
	13	60 90 013 6003
	14	60 90 014 6003
	18	60 90 018 6003
	20	60 90 020 6003
	25	60 90 025 6003
	34	60 90 034 6003
	40	60 90 040 6003
	48	60 90 048 6003
	50	60 90 050 6003

### Drawing

No. of pairs	Outside diameter	
	Nominal	Max
5	5.4	5.6
10	6.2	6.5
13	6.5	6.8
14	6.5	6.8
18	7.4	7.7
20	7.7	8.2
25	8.2	8.5
34	8.7	9.0
40	9.9	10.4
48	10.1	10.6
50	13.0	13.5

Dimensions in mm

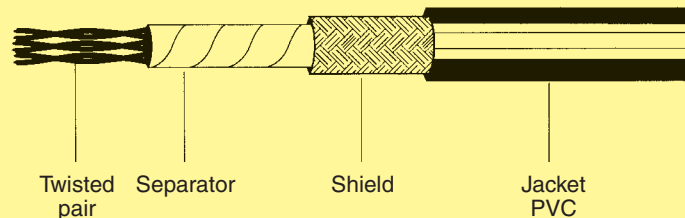

### Technical characteristics

Number of pairs	5, 10, 13, 14, 18, 20, 25, 34, 40, 48, 50	Propagation velocity	60 %
Voltage rating	30 V (style UL 2789)	Temperature range	- 20 °C ... + 105 °C
Maximum conductor resistance (20 °C)	233 Ω/km	<b>Cable materials</b>	
Minimum insulation resistance (20 °C)	1 MΩ/km	Conductor	7 x 0.13 mm stranded tinned copper
Nominal differential impedance (TDR)	85 Ω	Insulation (except 50 pairs) (for 50 pairs)	PVC Ø 0.62 mm PVC Ø 0.65 – 0.80 mm
Nominal differential capacitance (1 kHz)	110 pF/m	Shield	Tinned copper braid, covering ≥ 80 %
		Jacket	PVC
		Flammability rating	IEC 332-1
		Sheath marking	AWM 2789 60°C 30V VW1 36963

\* Except 60 90 050 6003: 150 m reel

## Cables for insulation displacement termination

Identification	No. of wires	Part No.
<b>Flat cable</b> for IDC connector Pitch 0.635 mm AWG 30  Length per reel: 100 ft 30.48 m	50 68	60 90 050 6008 60 90 068 6008

**Drawing** Dimensions in mm

	a	b	c	d
	± 0.25	± 0.05	± 0.2	± 0.05
50	31.75	0.635	31.12	0.68
68	43.20	0.635	42.55	0.68

The tolerance b is not cumulative

Technical characteristics	
Number of wires	50, 68
Voltage rating	150 V
Impedance	75 Ω
Nominal differential capacitance (1 kHz)	90 pF/m
Pitch	0.635 mm
UL style	2 678
Temperature range	- 30 °C ... + 105 °C
<b>Materials</b>	
Conductor	7 x 0.102 mm regular tinning or Z-bonding AWG 30
Insulation	PVC