

Light Curtains

Light Curtains for Lift

Type BFL



BFL E



BFL S

- Flexible connecting cables
- According to EN 81-70 requirements
- IP65 versions BFLxxxx200I, IP54 versions BFLxxxx200

- Protective screen for lift doors generated by light curtains
- Height version 200 cm
- Diodes position on the edge and on the side of the profile
- Output type: static opto-mosfet (70 mA) for NPN/PNP and voltage free contact
- Output working mode: NO or NC (selectable)
- 9.7 mm ultra slim PC-ABS plastic housing
- 4 m range
- Light immunity > 100 kLux
- Automatic signal level adjustment
- High speed scanning
- LED indication for power supply ON and system status
- Dynamic mounting (directly on the lift sliding doors)
- Static mounting (on the fixed walls of the lift opening) by optional kit (BFLMOUNT)
- Timeout and blanking functions

Product Description

The BFL series provides the protection of the lift car/passenger doors through a light curtain of infrared beams between the emitting and receiving units. Whenever a person or an object breaks at least one beam, the system is triggered causing the doors to re-open. In the same way, the BFL can be used for access openings in industrial production, in automatic stores for cargo monitoring and in many other applications.

The transmitting unit (TX) and the receiving unit (RX) are synchronized by the wire and are designed for dynamic and static mounting. The system is able to adjust the power of the signal depending on the distance between the two units, in order to minimise the power consumption and ensure maximum life-span of the components without any set up. No external control box is required.

Ordering Key

BFL 194 E 200 I

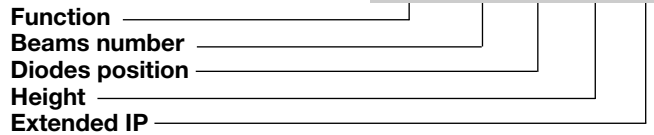

Type Selection

Height	Diodes number	Beams number (max.)	Diode position	Protection degree	Output	Supply 10 to 30 VDC
200 cm	22	104	Edge	IP65	opto-mosfet	BFL 104 E 200I
200 cm	40	194	Edge	IP65	opto-mosfet	BFL 194 E 200I
200 cm	22	104	Edge	IP54	opto-mosfet	BFL 104 E 200
200 cm	40	194	Edge	IP54	opto-mosfet	BFL 194 E 200
200 cm	22	104	Side	IP65	opto-mosfet	BFL 104 S 200I
200 cm	40	194	Side	IP65	opto-mosfet	BFL 194 S 200I
200 cm	22	104	Side	IP54	opto-mosfet	BFL 104 S 200
200 cm	40	194	Side	IP54	opto-mosfet	BFL 194 S 200

Output Specifications

Output Type	(TX)	NC static: opto-mosfet NO configuration selectable by connecting the NONC black wire on RX to ground. Voltage free contact V _{ON} 2.5 VAC/DC max 70 mA V _{max} 30 VDC (27 VAC rectified)
Load		

Supply Specifications

Power supply	Rated operational voltage through brown and blue wires	Overvoltage cat. 1 (IEC 60664) 10 to 30 VDC 18 to 27 VAC rectified
Rated operational current	TX RX	max. 50 mA max. 15 mA

General Specifications

Operating range	0 to 4 m	Timeout function	Enabled connecting the TOBK white wire on RX to GND Function activation time after diode(s) obstruction 10 s ± 2 s
Protected height	20.5 to 1846 mm	Blanking function	Teach-in at power supply on, after connecting the TOBK white wire on RX to VDC
Distance between the diodes	46.8 mm	Distance between bottom beam and bottom of housing	13.7 mm
BFL194x	46.8 mm	Distance between top beam and bottom of housing	1838.7 mm
BFL104x	46.8 mm	LEDs indication	TX RX
Bottom 4 diodes	46.8 mm		1 red, 1 yellow 1 red, 1 yellow (see details in the LEDs indication tables)
Top 18 diodes	93.6 mm	LEDs position indication	Approx. 10 cm from the top of the housing
Beam pattern	Self-adaptive, depending on the signal transmitting level	Environment	(EN 60529)
Typical values		Degree of protection	BFLxxxx200I IP 65 BFLxxxx200 IP 54
BFL104x		Pollution degree	3
< 70 cm:	22 beams (1 beam/LED)	Operating temperature	-5 to +55°C, R.H. < 95%
70 to 140 cm:	64 beams (3 beams/LED)	Storage temperature	-20 to +65°C, R.H. < 95%
> 140 cm:	104 beams (5 beams/LED)	Housing (TX, RX)	
BFL194x		Dimensions (W,H,L)	BFLxxxE 30 x 2001 x 9.7 mm BFLxxxS 16.4 x 2000 x 26 mm
< 35 cm:	40 beams (1 beam/LED)	Material	Plastic (PC-ABS)
35 to 70 cm:	118 beams (3 beams/LED)	Weight (TX, RX)	Approx. 1 Kg
> 70 cm:	194 beams (5 beams/LED)	Mounting	Dynamic Static
Light immunity	> 100 kLux		Standard mounting Optional mounting by the BFLMOUNT kit: BFLMOUNT200
Start-up time	300 ms @ 0 m 1800 ms @ 4 m	Approvals	UL, CSA
Reaction time		CE Marking	Yes
BFL104x	35 ms @ uniform illum. (L) + 5 ms if L-Lmax > 30 kLux	EMC	Immunity Emission
BFL194x	50 ms @ uniform illum. (L) + 5 ms if L-Lmax > 30 kLux		Electromagnetic Compatibility According to EN 12016 According to EN 12015
Alarm OFF delay	500 ms	According to	Protective height stated in EN 81-70 norm
Angular mounting tolerance			
Vertical	± 3.5° (@ 3 m)		
Horizontal	± 3.0° (@ 3 m) (see details in the Mounting Tolerance Diagrams)		
Linear mounting tolerance			
Vertical	± 4.0 mm (@ 0 m)		
Horizontal	± 2.0 mm (@ 0 m) (see details in the Mounting Tolerance Diagrams)		
RX-TX synchronisation	By wire		
Transmitting signal power level	Self-adaptive, depending on the distance between TX and RX		
Connecting cable	5 x 24AWG, PVC, not shielded		
Length	4 m		
Diameter	5.2 mm		

LEDs Indication

TX LED	Status	Description
L1 (red)	ON	• Power supply ON/ Transmitter operating
	OFF Flashing	• Unit not supplied • Wrong TX-RX transmission
L2 (yellow)	OFF	• Blanking function not enabled
	ON	• Blanking function enabled

RX LEDs	Status	Description
L1 (red)	ON	• Power supply ON/ Receiver operating
	OFF Flashing	• Unit not supplied • Alarm condition
L2 (yellow)	OFF	• Timeout function not enabled
	ON Flashing	• Timeout function enabled • Timeout function enabled and at least 1 diode excluded

Function Setting

If the NONC (black) wire is not connected, the BFL is in NC output configuration. Select the NO output function by connecting the NONC wire on RX to ground.

If the TOBK (white) wire on RX is not connected, both Timeout and Blanking function are not enabled.

Select the Timeout function by connecting the TOBK wire to GND.

Select the Blanking function by connecting the TOBK wire to VDC.

Mode of Operation

Provided with a height of 200 cm, the BFL series ensures a beam pattern produced by infrared diodes. Depending on the distance between the transmitter (TX) and the receiver (RX) or, in general, depending on the signal transmitting level, each diode produces 1 direct beam, 3 or 5 beams. The BFL can be connected

directly to the lift-controller if it can provide 10 to 30 DC voltage. Otherwise, we recommend to use a suitable power supply unit.

Timeout function.

The function is enabled by connecting the TOBK white wire on RX to GND at start up (before supplying the

light curtain). This feature allows up to 5 non-adjacent diodes to be ignored in case they are obstructed for more than 10 seconds, in order to enable detectors defaced by vandalism to continue working until arrangements or replacements.

Blanking function.

This function allows to inhibit parts of the light curtain beam pattern. By connecting to VDC the TOBK wire on RX before supplying BFL, the system permanently saves the configuration (15 seconds of teaching-in are needed). To reset the pattern, it is necessary to disconnect the wire.

Wiring Diagrams

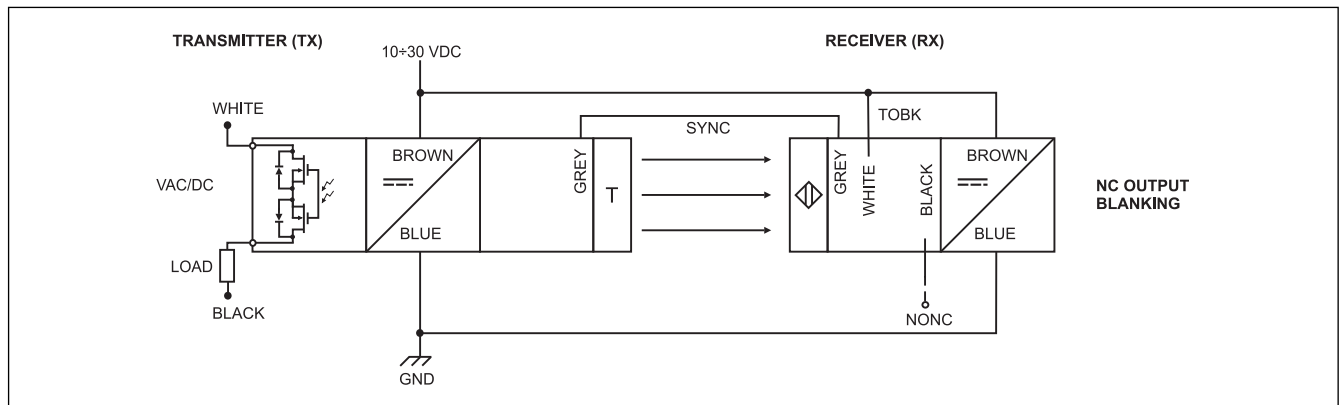
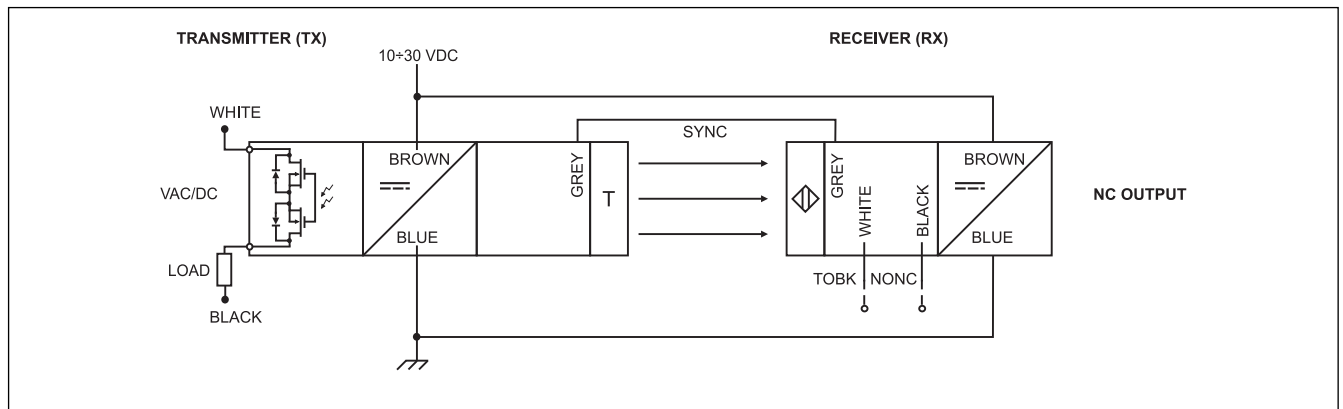

Wiring Diagrams (cont.)

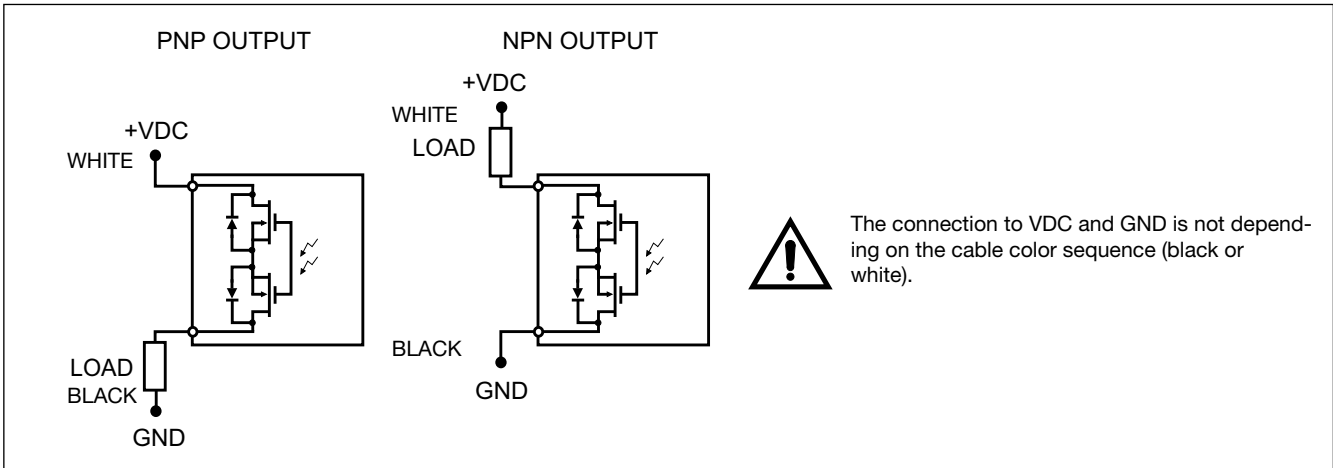
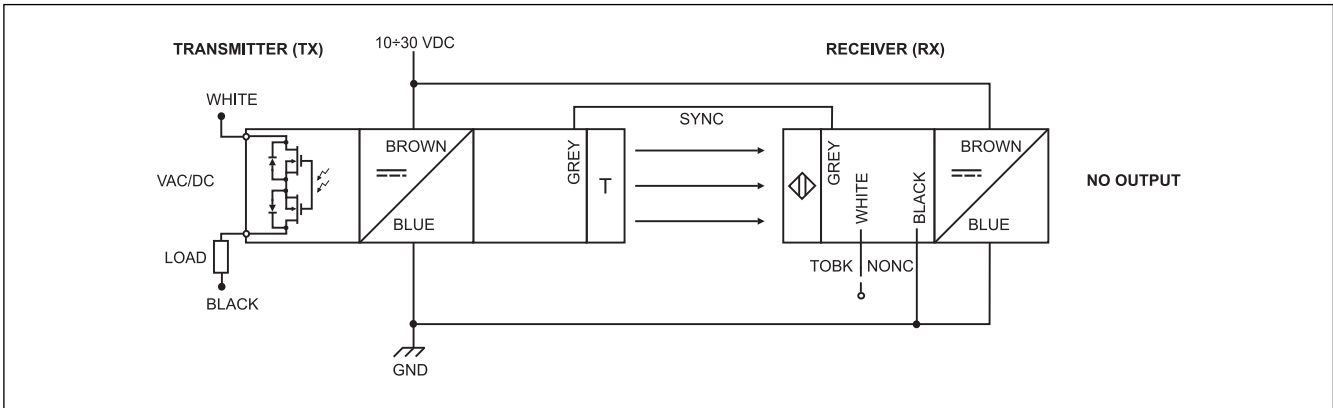
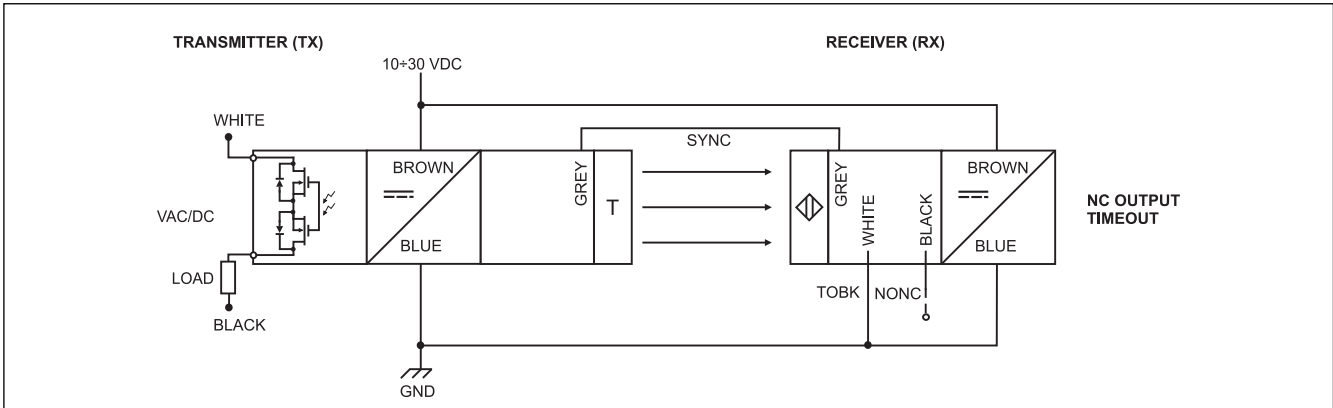

Beam Pattern

BFL104x200x

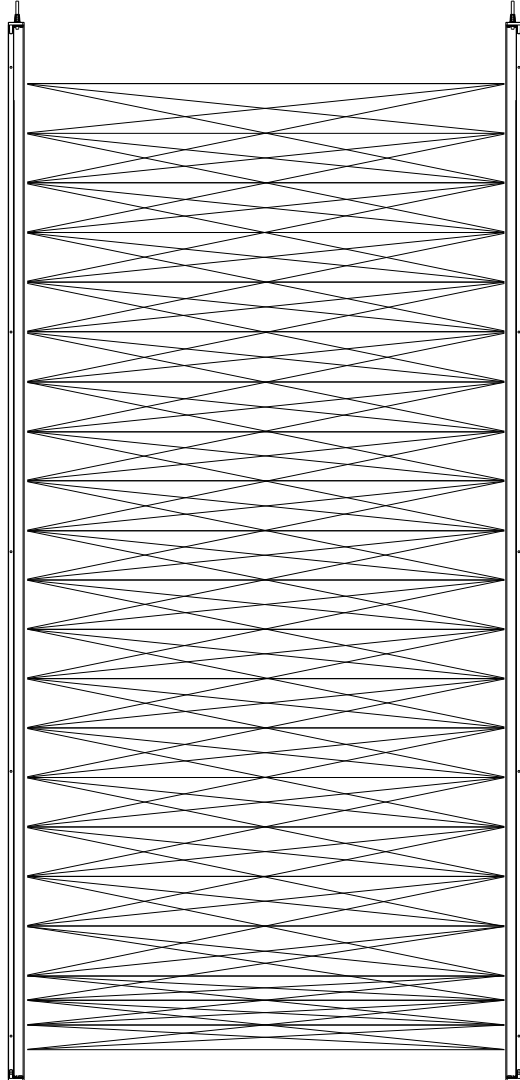

BFL194x200x

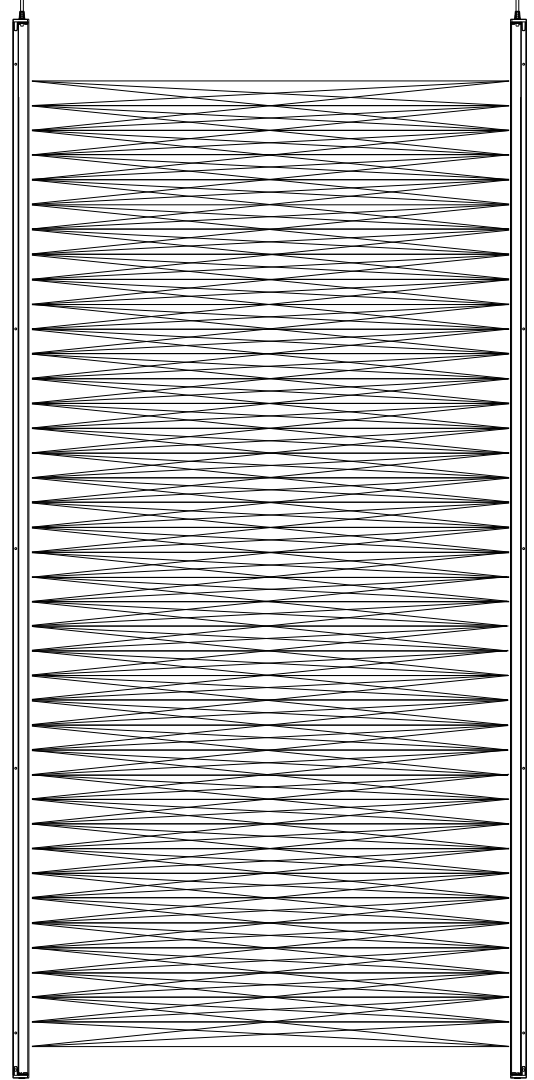

Dimensions BFLxxxE200x

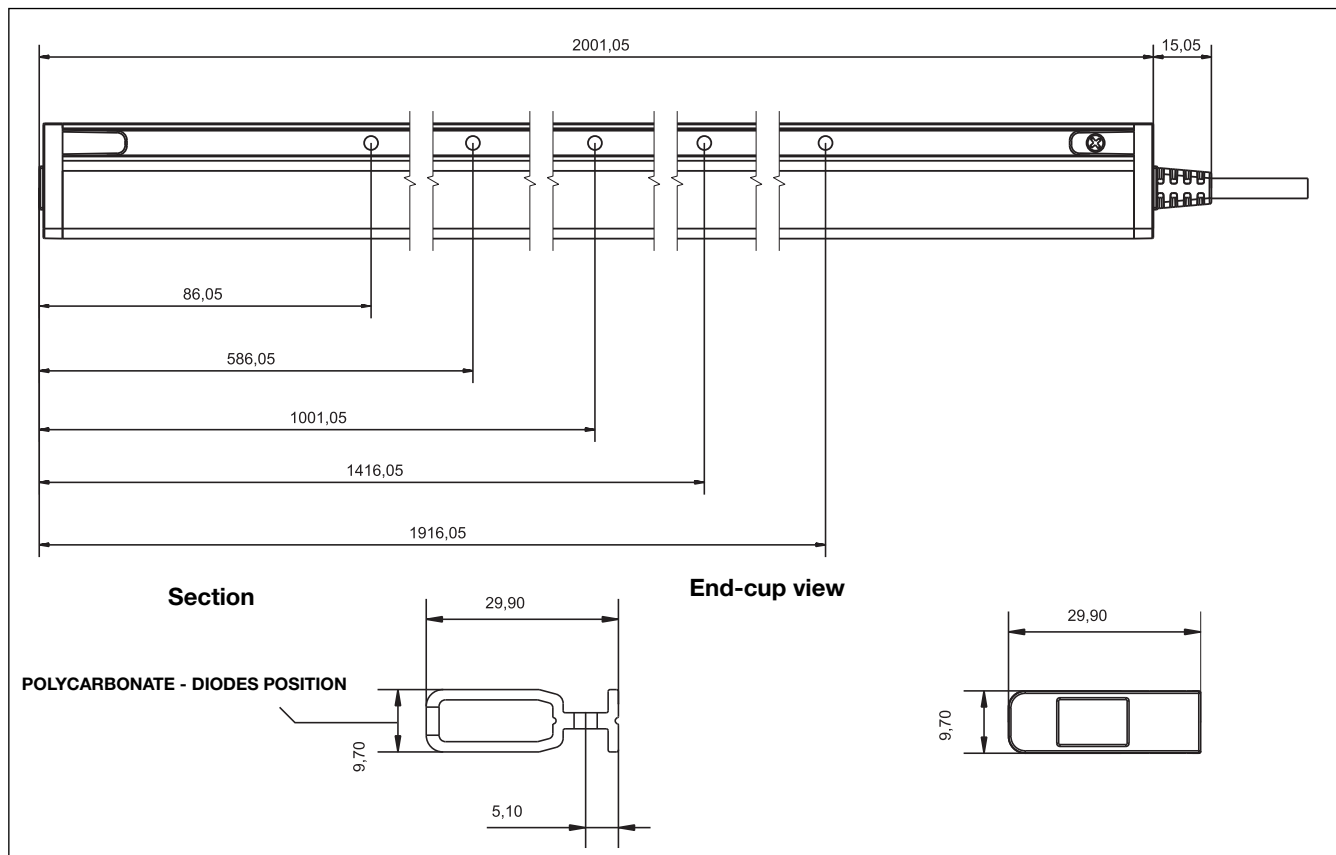

Dimensions BFLxxxS200x

