



a module solution provider

# **WA6800-00**

## **WiFi Audio Solution Module**

**MIPS24Kc processor + DDR3 + NOR flash**

**USB / SPDIF / I2C / UART Interface**

**192 k / 24 bit Audio Quality**

**802.11b/g/n + PCB Antenna**

**WiFi Logo Certification**

**FCC / CE Certification**

**Reliability Validation**

**Version 2.0 / Aug 20th, 2014**

Copyright © JORJIN TECHNOLOGIES INC. 2014

<http://WWW.JORJIN.COM.TW>

CONFIDENTIAL

## Contents

GENERAL DESCRIPTION -----	3
1 FEATURES INDRODUCTION-----	3
2 FUNCTION BLOCK DIAGRAM -----	4
3 PIN OUT DESCRIPTION-----	6
4 POWER DESCRIPTION-----	7
5 CHARACTERISTIC-----	8
6 I/O INTERFACE -----	11
7 VERIFIED TR PROTOCOL -----	12
8 WiFi LOGO CERTIFICATION-----	13
9 FCC / CE CERTIFICATION-----	13
10 RELIABILITY TEST -----	13
11 MECHANICAL DIMESION -----	14

## GENERAL DESCRIPTION

The WA6800-00 is a highly integrated audio decoder designed for local playback and wireless streaming applications. Main features of the module include major kind of decoders, DDR and NOR devices, USB / UART /I2C /SPDIF /Digital Audio interface, and build in PCB antenna.

### 1. FEATURES INTRODUCTION

#### 1.1 System and Peripherals

- Board Size: L x W x H = 30mm x 62.2mm x 9.6mm
- 500MHz MIPS24Kc processor
- Audio engine with HW acceleration
- 128MB DDR3 SDRAM with 16-bit data interface
- 16MB Serial NOR Flash with dual I/O data interface
- USB 2.0 High Speed Host controller and PHY
- Supports UART /IrDA/I2C/GPIO/SPDIF/ Digital Audio interface.

#### 1.2 Wireless LAN

- CMOS MAC, Baseband PHY, and RF in a single chip for IEEE 802.11b/g/n compatible WLAN
- Complete 802.11n solution for 2.4GHz band
- 72.2Mbps receive PHY rate and 72.2Mbps transmit PHY rate using 20MHz bandwidth
- 150Mbps receive PHY rate and 150Mbps transmit PHY rate using 40MHz bandwidth
- IEEE 802.11e QoS Enhancement (WMM) support
- 802.11i (WPA, WPA2). Open, shared key, and pair-wise key authentication services
- Supports Wake-On-LAN (WOL)

#### 1.3 Audio Interface and Function

- Built-in Audio DAC with 24-bit resolution
- IEC-60958 (SPDIF) digital audio output
- LPCM, ADPCM, FLAC, AAC, WAV, and OGG Vorbis
- RA1/RA-cook/RA-lossless, and WMA/WMA Pro (Licensee Only)

## 2. Function Block Diagram

### 2.1 Module Diagram

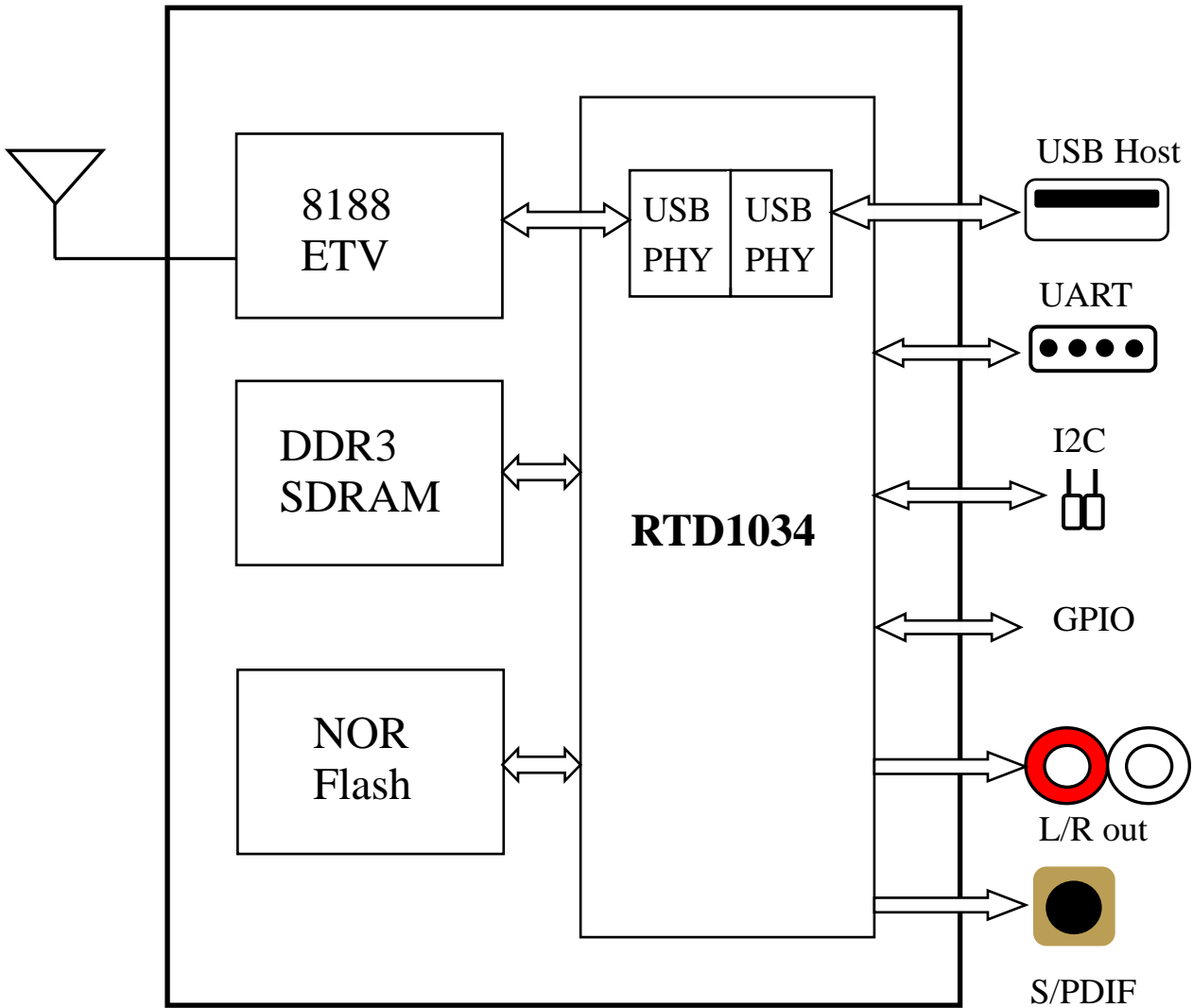
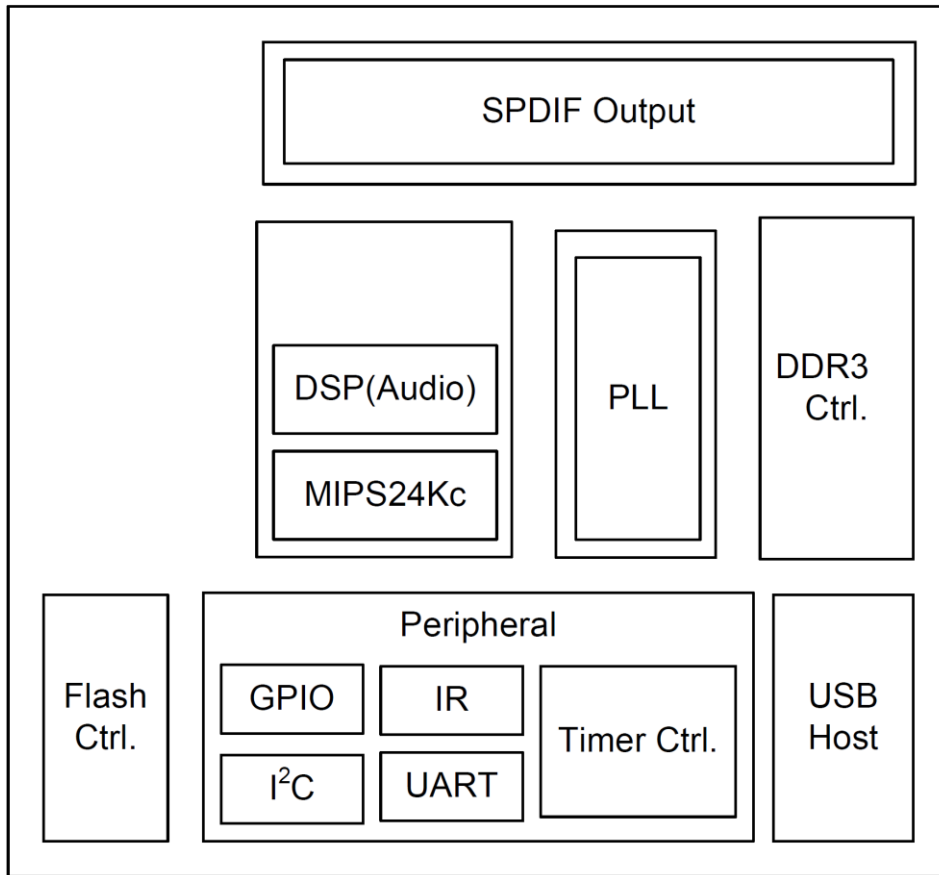

figure 1. Module Diagram

## 2.2 RTD1034 Diagram



## 3. Pin Out description

### 3.1 Pin-out connector

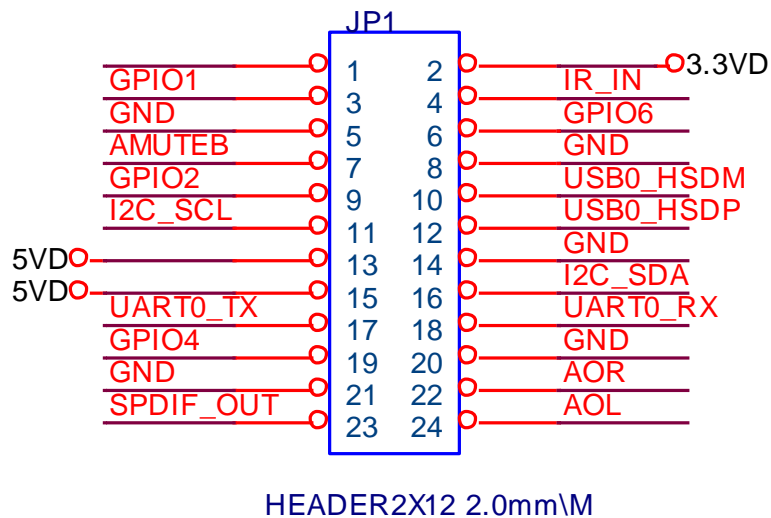

### 3.2 Pin Out Description

<b>P</b>	<b>Name</b>	<b>Type</b>	<b>Description</b>
1	NC		
2	3.3VD	Power	Power 3.3V output
3	GPIO1	I/O	Isolation General Purpose IO
4	IR_IN	Input	Infrared Input from IR Receiver
5	GND	Ground	System ground
6	GPIO6	I/O	Isolation General Purpose IO
7	AMUTEB	Mute	Audio console
8	GND	Ground	System ground
9	GPIO2	I/O	General Purpose IO
10	USB0_HSDM	Differential	USB D- Signal
11	I2C0_SCL	clock	I2C Serial Clock Output
12	USB0_HSDP	Differential	USB D+ Signal
13	5VD	Power	System Power DC in
14	GND	Ground	System ground
15	5VD	Power	System Power
16	I2C0_SDA	Data	I2C Serial Data Signal
17	UART0_TX	Serial	UART Transmit Data Output
18	UART0_RX	Serial	UART Receive Data Input
19	GPIO4	I/O	Isolation General Purpose IO
20	GND	Ground	System ground
21	GND	Ground	System ground
22	AOR	DAC out	Audio DAC Output R-Channel
23	SPDIF OUT	S/PDIF	IEC60958 (SPDIF) Output
24	AOL	DAC out	Audio DAC Output L-Channel

## 4. POWER DESCRIPTION

### 4.1 power supply

Adequate power and ground is provided for high-speed digital and sensitive analog design and Wireless LAN .

Power	Min.	Typ.	Max.	Unit	Description
5V	4.5	5	5.5	V	System Power
1.0V	-	1.0	-	V	Core Digital Logic of RTD1034
1.0V	-	1.0	-	V	Analog Logic of RTD1034
ISO_1.0V	1.05	1.05	-	V	Power Supply of Isolated Block Logic
1.5V	-	1.5	-	V	SSTL15 I/O Pad
3.3V	3.0	3.3	3.6	V	Power Supply of I/O / Wifi / Flash
RTC_3.3V	1.0	3.3	-	V	Power Supply of RTC Block
DVRI	-	0.75	-	V	I/O reference voltage of SSTL15 Interface
1.2V	-	1.2	-	V	RTL8188 Core Supply Voltage
1.5V	-	1.5	-	V	RTL8188 Supply Voltage
IDD33	-	-	600	mA	RTL8188 3.3V Rating Current

### 4.2 Electrical Characteristics of LVTTTL I/O Pads

LVTTTL Specification

Symbol	Parameter	Min.	Typ.	Max.	Unit	Condition
V <sub>IH</sub>	HIGH Level Input Voltage	2.0	-	-	V	-
V <sub>IL</sub>	LOW Level Input Voltage	-	-	0.8	V	-
V <sub>OH</sub>	HIGH Level Output Voltage	V <sub>CC</sub> -0.2	V <sub>CC</sub>	-	V	-I <sub>O</sub> = 20μA
V <sub>OL</sub>	LOW Level Output Voltage	-	-	0.4	V	I <sub>O</sub> = 4.0mA
±I <sub>I</sub>	Input Leakage Current	-	1	2	μA	V <sub>IN</sub> ≥ V <sub>IH</sub> or V <sub>IN</sub> ≤ V <sub>IL</sub>

### 4.3 Suspend Function

The RTD1034NA provides a Sleep Mode that shuts down all functions but WLAN to save power during idle state. Sleep Mode is entered via a software instruction sequence, and exited by a Wake On WLAN or a hardware reset.

### 4.4 Power-On Sequence

Generally, the power-on sequence should be as follows

- ◆ Apply 3.3V, 1.0V, and 1.5V
- ◆ Wait for power supplies to be stable
- ◆ Reset operation completes
- ◆ System boots up

#### POR Circuit Specification

Parameter	Description	TYP.	Unit
3.3V <sub>MIN</sub>	Minimum Voltage to De-Assert POR	2.5	V
1.0V <sub>MIN</sub>	Minimum Voltage to De-Assert POR	0.8	V
3.3V <sub>DROP</sub>	Trigger Voltage to Assert POR	2.0	V
1.0V <sub>DROP</sub>	Trigger Voltage to Assert POR	0.75	V
t <sub>POR</sub>	POR Reset Time	2 <sup>20</sup>	Cycles
t <sub>1</sub>	Lead Time between 1.0V and 3.3V	2	mS

#### Power-On Sequence Timing

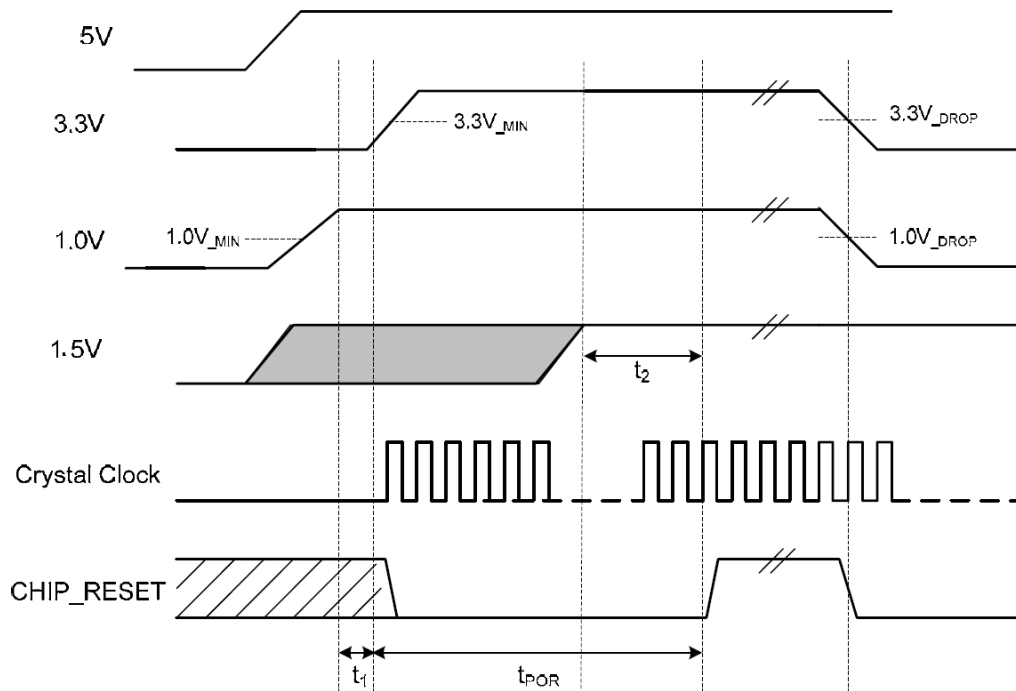

## 5. Characteristic

### 5.1 Module Characteristic

<b>PRODUCT</b>	WiFi Audio
<b>MODEL NO.</b>	WA6800
<b>TYPE OF THE EQUIPMENT</b>	DIP
<b>NOMINAL VOLTAGE</b>	5 Vdc
<b>VOLTAGE OPERATING RANGE</b>	Vnom= 5    Vmin= 4.5    Vmax= 5.5
<b>OPERATION TEMPERATURE</b>	-20 ~ 85
<b>MODULATION TYPE</b>	CCK, DQPSK, DBPSK for DSSS
	64QAM, 16QAM, QPSK, BPSK for OFDM
<b>MODULATION TECHNOLOGY</b>	DSSS, OFDM
<b>OPERATING FREQUENCY</b>	2412 ~ 2442MHz
<b>TRANSFER RATE</b>	802.11b: 11/5.5/2/1Mbps
	802.11g: 54/48/36/24/18/12/9/6Mbps
	802.11n: MCS0 ~ MCS7
<b>NUMBER OF CHANNEL</b>	1~ 13
<b>EIRP POWER</b>	15.3 db
<b>ANTENNA TYPE</b>	PCB antenna with -0.43 dBi gain
<b>I/O PORTS</b>	Refer to user's manual
<b>ESD(HBM)</b>	2000V
<b>ESD(MM)</b>	200V

### 5.2 Module Power Consumption

		Votage (V)		I (mA)		Pd (mW)	
		Tye	Max.	Typ	Max	Typ	Max
System power	5.0V	5	5.5	240	260	1200	1430

5.3 WLAN Characteristic

WLNA Transmitter						
Characteristics	Condition	MAX EVM	Min	Tyd	Max	Unit
11b Output Power	11M CCK	35%	14.0	15.67	-----	dbm
	5.5M CCK	35%	14.0	15.73	-----	
	2M DSSS	35%	14.0	15.69	-----	
	1M DSSS	35%	14.0	15.65	-----	
11g Output Power	54M OFDM	-25	12.2	13.73	-----	
	48M OFDM	-25	12.2	13.76	-----	
	36M OFDM	-19	12.2	13.77	-----	
	24M OFDM	-19	12.2	13.75	-----	
	18M OFDM	-13	12.2	13.77	-----	
	12M OFDM	-13	12.2	13.78	-----	
	9M OFDM	-8	12.2	13.73	-----	
11n Output Power	6M OFDM	-8	12.2	13.79	-----	
	MCS7	-28	11.0	12.69	-----	
	MCS0	-5	11.0	12.72	-----	

WLNA Receive					
Characteristics	Condition	Min	Tyd	Max	Unit
11b Rx Sensitivity	11M CCK	-----	-96	-83	dbm
	5.5M CCK	-----	-94	-87	
	2M Barker	-----	-91	-90	
	1M Barker	-----	-87	-92	
11g Rx Sensitivity	54M OFDM	-----	-75	-71	
	48M OFDM	-----	-76	-72	
	36M OFDM	-----	-81	-77	
	24M OFDM	-----	-84	-80	
	18M OFDM	-----	-87	-83	
	12M OFDM	-----	-89	-85	
	9M OFDM	-----	-91	-87	
11n Rx Sensitivity	6M OFDM	-----	-92	-88	
	MCS7	-----	-72	-68	
	MCS0	-----	-91	-87	

## 5.4 Audio Performance

DAC quality		
DAC(10K Ohm Loading)		
Resolution	24	Bits
THD+N (1KHZ, 0dB)	-83	dBFS
SNR(1KHz, -60dB)	93d	BFS
Output level (20Hz)	-0.07	dBFS
Output level (20KHz)	-0.07	dBFS
Output Voltage (1KHz)	1.04	V rms
SPDIF quality		
DAC(10K Ohm Loading)		
Resolution	24	Bits
THD+N (1KHZ, 0dB)	-136	dBFS
SNR(1KHz, -60dB)	93d	BFS
Output level (20Hz)	0	dBFS
Output level (20KHz)	0	dBFS
Output Voltage (1KHz)	139	V rms

## 6. I/O INTERFACE

One set of USB / I2C / UART / R-L audio / SPDIF and three GPIO interfaces are supported.

### UART Application Diagram

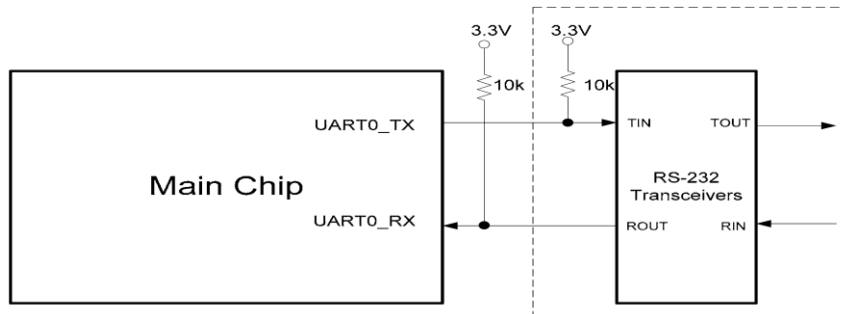

This UART is used to debug function.

### I2C Application Diagram

Currently, I2C is used for MFI certification processor.

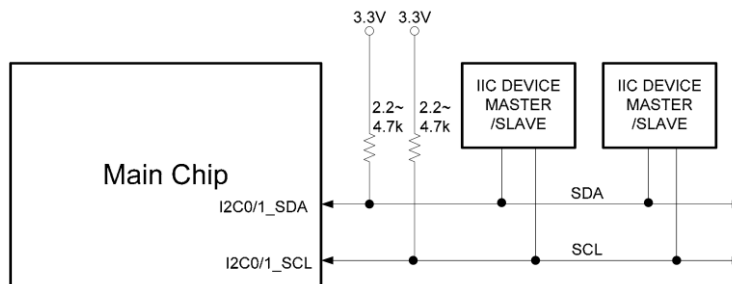

### USB Application Diagram

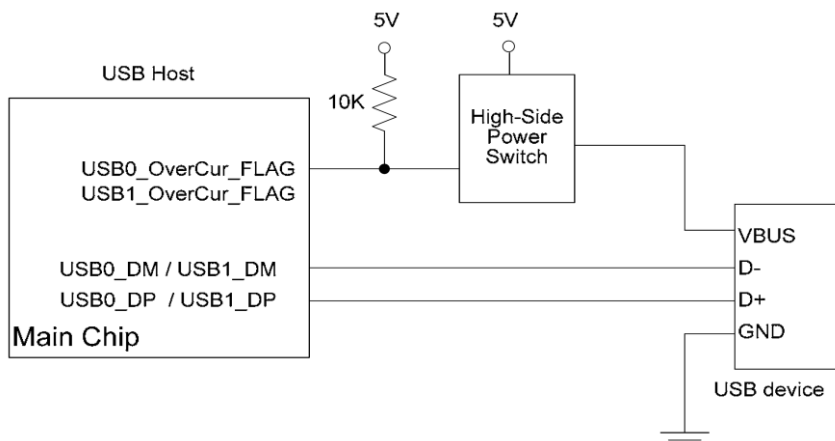

## 7. VERIFIED IR PROTOCOL

### 7.1 NEC Protocol

- Address and command are transmitted twice for reliability
- Pulse distance modulation
- Carrier frequency of 38kHz
- Bit time of 1.12ms or 2.25ms

### 7.2 Sony SIRC Protocol

- Pulse width modulation
- Carrier frequency of 40kHz
- Bit time of 1.2ms or 0.6ms

### 7.3 Philips RC-5 Protocol

- Bi-phase coding
- Carrier frequency of 36kHz
- Constant bit time of 1.8ms

### 7.4 Philips RC-6A Protocol (Mode 0 Only)

- Bi-phase coding
- Carrier frequency of 36kHz
- Constant bit time of 888 $\mu$ s (except trailer bit)

### 7.5 Sharp Protocol

- Pulse distance modulation
- Carrier frequency of 38kHz
- Bit time of 1ms or 2ms

### 7.6 IR Protocol

- IR Verified Protocol

## 8. WIFI LOGO Certification

TBD

## 9. FCC/CE Certification

TBD

## 10. RELIABILITY Test Plan

WA6800-00 WiFi Audio Module Reliability Plan				
Items	Test Condition	Test Duration	Sample Size (ea)	Reference
1.High Temp. Storage Life Test. HTSL	70°C · No Bias Check point at 300hrs	500hrs	5	JESD 22-A103
2.Temperature Humidity Test. THT	70°C · 85%RH Check point at 300hrs	500hrs	5	JED-4701 method102
3.High Temperature Operating Life Test.HTOL	70°C · Vmax bias, dynamic Check point at 300hrs	500hrs	5	JESD22-A108
4.Vibration	TI conditions: max acceleration 20G, 20 - 2000 - 20 Hz Log sweep, 4 mins per cycle, performed 4 times in each orientation of X, Y, Z (3 perpendicular directions).	3hrs	5	JESD22-B103B
5.Drop	Peak 1500G+/-10%, pulse 1.0ms+/-10%	3hrs	5	JESD22-B111

## 11. MECHANICAL DIMENSION

11.1 Product's Outline : W x L x H = 62.2 x 30 x 9.6 mm

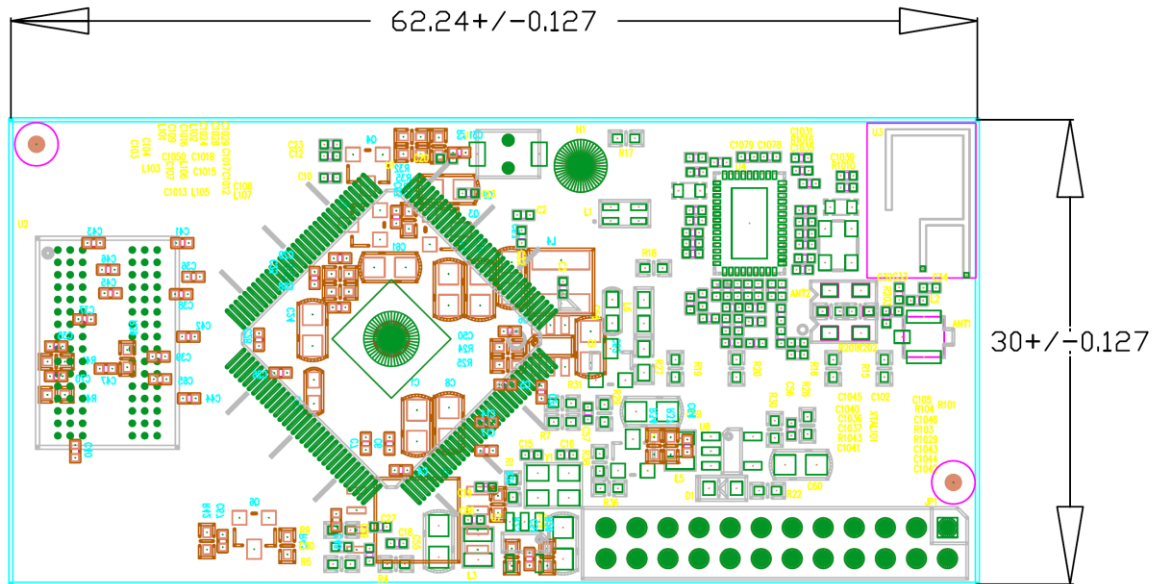

### 11.2 Connector's Outline

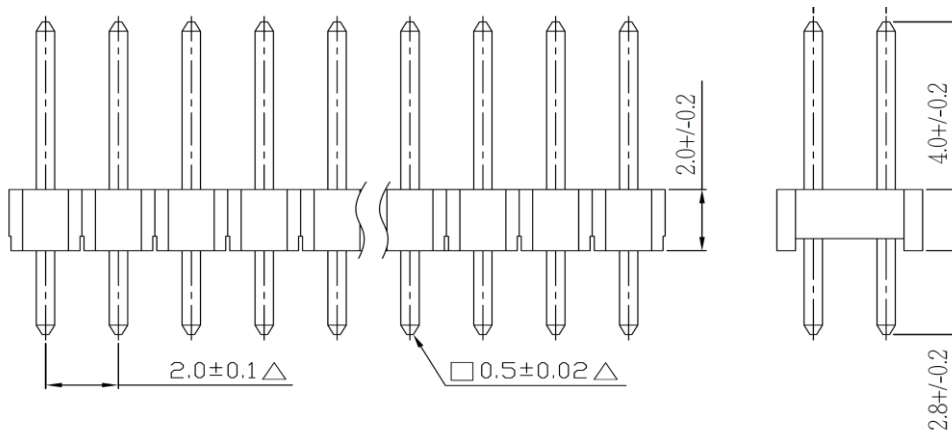

### 11.3 PCB Hole Layout

