



Main

Commercial Status	Commercialised
Range of product	Twido
Product or component type	Compact base controller
Discrete I/O number	24
Discrete input number	14
Discrete input voltage	24 V
Discrete input voltage type	DC
Discrete output number	10 for relay
[Us] rated supply voltage	100...240 V AC
Number of I/O expansion module	4
Use of slot	Memory cartridge or realtime clock cartridge
Data backed up	Internal RAM (lithium) 30 days, charging time = 10 h, battery life = 10 yr
Integrated connection type	Non isolated serial link mini DIN, Modbus/character mode master/slave RTU/ASCII (RS485) half duplex, 38,4 kbit/s Serial link interface adaptor (RS232C/RS485) Power supply
Complementary function	Event processing PID

Complementary

Discrete input logic	Sink or source
Input voltage limits	20.4...28.8 V
Discrete input current	7 mA for I0.2 to I0.13 11 mA for I0.0 to I0.1
Input impedance	3400 Ohm for I0.2 to I0.13 2100 Ohm for I0.0 to I0.1
Filter time	45 µs + programmed filter time for I0.0 to I0.5 at state 0 40 µs + programmed filter time for I0.6 to I0.13 at state 1 35 µs + programmed filter time for I0.0 to I0.5 at state 1 150 µs + programmed filter time for I0.6 to I0.13 at state 0
Insulation between channel and internal logic	1500 Vrms for 1 minute
Insulation resistance between channel	None
Minimum load	0.1 mA
Contact resistance	<= 30000 µOhm
Load current	2 A at 30 V DC resistive load, operating rate = 30 cyc/mn for relay output 2 A at 30 V DC inductive load, operating rate = 30 cyc/mn for relay output 2 A at 240 V AC resistive load, operating rate = 30 cyc/mn for relay output 2 A at 240 V AC inductive load, operating rate = 30 cyc/mn for relay output
Mechanical durability	>= 20000000 cycles for relay output
Electrical durability	>= 100000 cycles for relay output
Current consumption	55 mA at 24 V DC at state 1 5 mA at 5 V DC at state 0 36 mA at 5 V DC at state 1
I/O connection	Non-removable screw terminal block
Input/Output number	<= 88 with removable screw terminal block with I/O expansion module <= 152 with HE-10 connector with I/O expansion module <= 120 with spring terminal block with I/O expansion module
Network frequency	50/60 Hz

Supply voltage limits	85...264 V
Network frequency limits	47...63 Hz
Power supply output current	0.25 A for 24 V DC sensors
Power supply input current	450 mA
Inrush current	<= 40 A
Protection type	Power protection with internal fuse
Power consumption in VA	40 VA at 264 V 33 VA at 100 V
Insulation resistance	> 10 MOhm at 500 V, between supply and earth terminals > 10 MOhm at 500 V, between I/O and earth terminals
Program memory	3000 instructions
Exact time for 1 K instruction	1 ms
System overhead	0.5 ms
Memory description	Internal RAM, double words, no floating, no trigonometrical Internal RAM, 3000 internal words, no floating, no trigonometrical Internal RAM, 256 internal bits, no floating, no trigonometrical Internal RAM, 128 timers, no floating, no trigonometrical Internal RAM, 128 counters, no floating, no trigonometrical
Free slots	1
Realtime clock	Without
Counting input number	3 channel(s) at 5000 Hz 16 bits 1 channel(s) at 20000 Hz 32 bits
Analogue adjustment points	1 point adjustable from 0...1023 1 point adjustable from 0 to 511 points
Status LED	1 LED red for module error (ERR) 1 LED per channel green for I/O status 1 LED green for RUN 1 LED green for PWR 1 LED for user pilot light (STAT)
Terminals description PLC n°1	(-)PW_OUT_NEG (+)PW_OUT_POS (0)IN_DIS#0 (1)IN_DIS#1 (10)IN_DIS#10 (11)IN_DIS#11 (12)IN_DIS#12 (13)IN_DIS#13 (2)IN_DIS#2 (3)IN_DIS#3 (4)IN_DIS#4 (5)IN_DIS#5 (6)IN_DIS#6 (7)IN_DIS#7 (8)IN_DIS#8 (9)IN_DIS#9 ALT COM_NEG#0-13 TB_TOP
Terminals description PLC n°2	(-)PW_OUT_NEG (+)PW_OUT_POS (0)IN_DIS#0 (1)IN_DIS#1 (10)IN_DIS#10 (11)IN_DIS#11 (12)IN_DIS#12 (13)IN_DIS#13 (2)IN_DIS#2 (3)IN_DIS#3 (4)IN_DIS#4 (5)IN_DIS#5 (6)IN_DIS#6 (7)IN_DIS#7 (8)IN_DIS#8 (9)IN_DIS#9 ALT_1 COM_POS#0-13 TB_TOP

Terminals description PLC n°3	(-)PW_NEG (+)PW_POS (0)OUT_DIS#0 (1)OUT_DIS#1 (2)OUT_DIS#2 (3)OUT_DIS#3 (4)OUT_DIS#4 (5)OUT_DIS#5 (6)OUT_DIS#6 (7)OUT_DIS#7 (8)OUT_DIS#8 (9)OUT_DIS#9 (COM0)COM#0-3 (COM1)COM#4-7 (COM2)COM#8 (COM3)COM#9 (GND)GROUND TB_BOTTOM
-------------------------------	--

Product weight	0.305 kg
----------------	----------

Environment

Immunity to microbreaks	10 ms
Dielectric strength	1500 V for 1 minute, between supply and earth terminals 1500 V for 1 minute, between I/O and earth terminals
Product certifications	CSA UL
Marking	CE
Ambient air temperature for operation	0...55 °C
Ambient air temperature for storage	-25...70 °C
Relative humidity	30...95 % without condensation
IP degree of protection	IP20
Operating altitude	0...2000 m
Storage altitude	0...3000 m
Vibration resistance	4 gn, 25...100 Hz mounting on: plate or panel with fixing kit 1.6 mm, 2...25 Hz mounting on: plate or panel with fixing kit 1 gn, 57...150 Hz mounting on: 35 mm symmetrical DIN rail 0.075 mm, 10...57 Hz mounting on: 35 mm symmetrical DIN rail
Shock resistance	15 gn for 11 ms

Not classified

Depth	70 mm
Height	95 mm
Width	90 mm

Dimensions

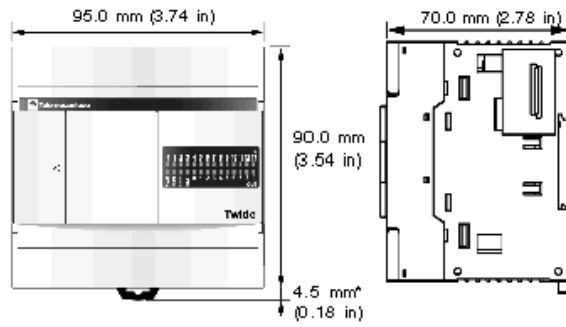

* 8.5 mm (0.33 in) when the clamp is pulled out.

Minimum Clearances for a Compact Base and Expansion I/O Modules

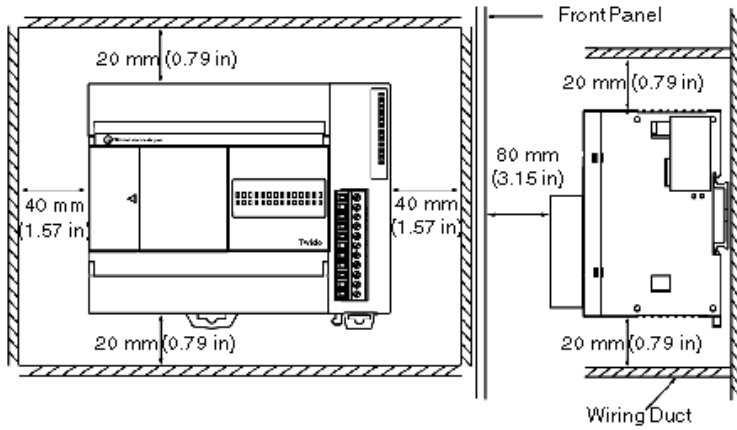

Mounting Hole Layout

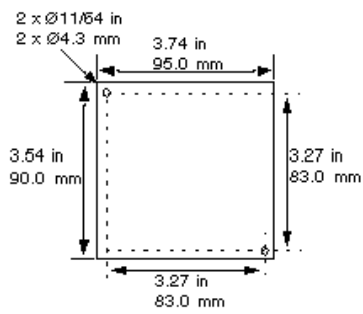

AC Power Supply Wiring Diagram

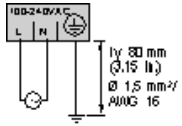

DC Source Inputs Wiring Diagrams

External Power

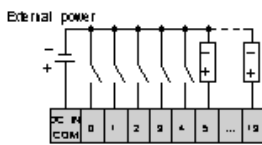

Internal Power

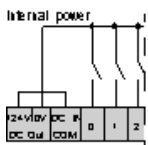

Max current: 250mA.

DC Sink Inputs Wiring Diagrams

External Power

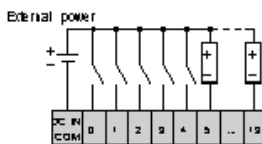

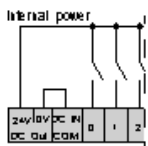

Internal Power

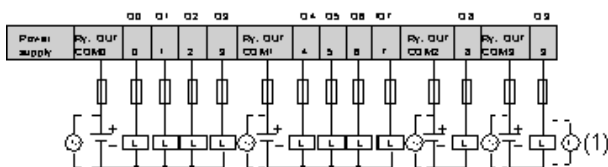

Max current: 250mA.

Relay and Transistor Outputs Wiring Diagram



(1) 

Performance Curves

I/O Usage Limits

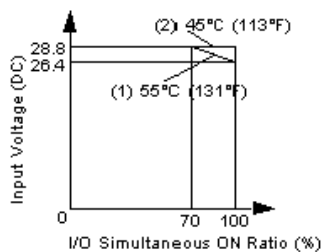

- (1) Limit for TWDLCA•AA16DRF, TWDLCA•A24DRF, TWDLCA•40DRF and TWDLCA•40DRF
- (2) All compact bases