

NEW PRODUCT INFORMATION

San Ace 120AD ^{9AD type} AC Fan

SANYO DENKI EUROPE SA. is pleased to introduce its **San Ace 120AD** AC fan, measuring 120mm square by 38mm thick. This fan works while internally converting AC power into DC power and provides the superior performance of a DC fan with the flexibility of AC input.



Product Features

- 1 Low Power Consumption**
up to 76% reduction
- 2 High Reliability**
expected life time 60,000 hours at 60°C
- 3 Wide Range of Input Voltage**
rated voltage 100 to 240VAC
- 4 Stable Rotating Speed**
even at different input voltage and frequency conditions

How to read Model Number

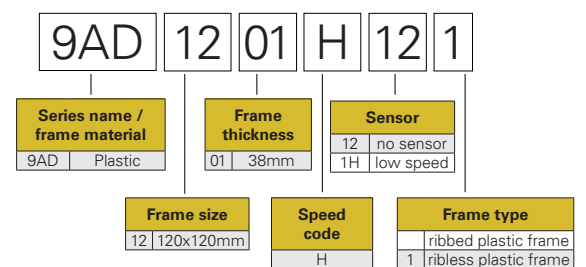

Air flow - Static pressure

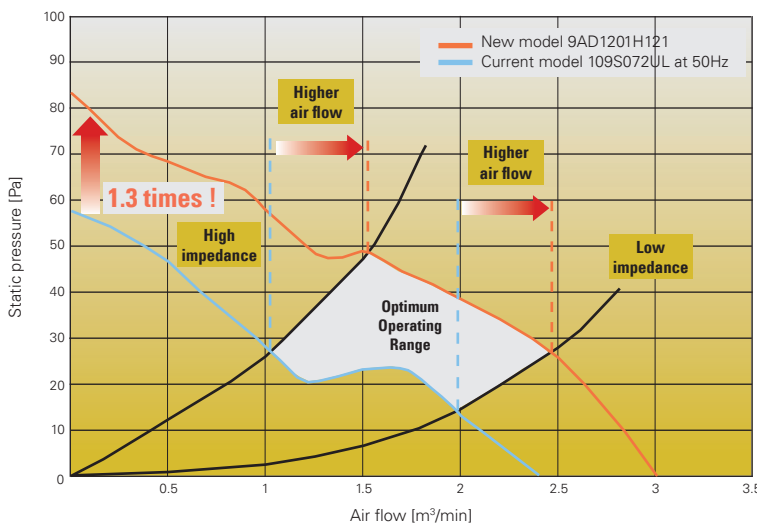

Performance Comparison

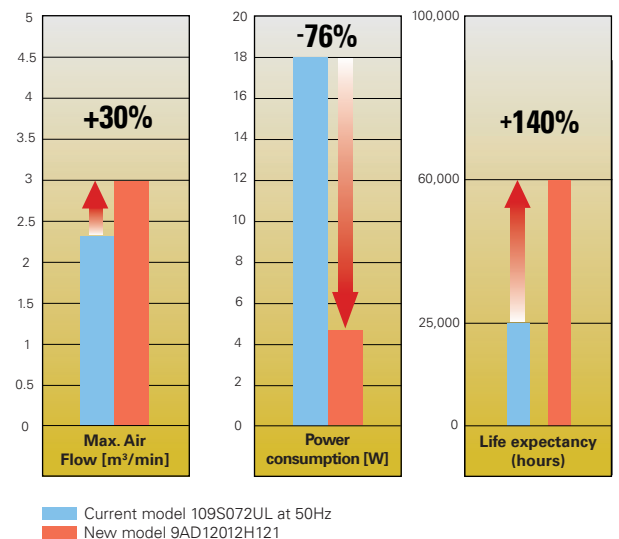

Main Specifications

- Size 120mm square by 38mm thickness
- Air flow 3m³/min - 106CFM
- Static pressure 84Pa
- Rated voltage 100 to 240VAC
- Expected life time 60,000 hours at 60°C
- Sensor low speed sensor, pulse sensor & lock sensor (in option)

Target Applications

- Industry and factory automation
- Cabinets
- Air ventilation
- Measuring instruments
- Data storage
- PV inverters...

For further information on **San Ace 120AD** AC fan, please contact us at **+33 1 48 63 26 61** or email us at **info@sanyodenki.eu**.

AC Fan

San Ace 120AD

9AD type

Features

Low Power Consumption

Power consumption is reduced by approximately 72% compared with our conventional AC fan.*

Long Life

The San Ace 120AD has an expected life of 60,000 hours (approximately 6 years), approximately 2.4 times that of our conventional AC fan.*

Wide Range

A rated voltage range of 100 to 240 VAC allows for usage in both 100 VAC and 200 VAC systems. Rotation speed remains constant even at different input voltages.

* Our conventional AC fan is 120 x 120 x 38 mm "San Ace 120", Model No. 109S072UL at a frequency of 60 Hz.



(Ribless model depicted)

120×120×38mm

Specifications

The model no. below has **ribs and no sensors**. For models without ribs, append "1" to the model no.

Model No.	Rated Voltage [V]	Operating Voltage Range [V]	Frequency ^(Note) [Hz]	Rated Current [A]	Rated Input [W]	Rated Speed [min ⁻¹]	Max. Air Flow [m ³ /min] [CFM]	Max. Static Pressure [Pa] [inchH ₂ O]	SPL [dB(A)]	Operating Temperature [°C]	Expected Life [h]
9AD1201H12	100 to 240	90 to 264	50/60	0.08	4.4	3,250	3.0 106	84 0.34	42	-20 to +75	60,000

Note: 50/60 Hz compatible.

Available options: **Low Speed Sensor**

Please contact us for details on the following specifications: **Pulse Sensor** **Lock Sensor**

Common Specifications

- Material Frame: Plastics (Flammability: UL94V-0), Impeller: Plastics (Flammability: UL94V-1)
- Expected Life Refer to specifications
(L10: Survival rate: 90% at 60 °C, rated voltage, and continuously run in a free air state)
- Motor Protection System Burnout protection at locked rotor condition
- Dielectric Strength 50/60 Hz, 1,500 VAC, 1 minute
(between power terminal and frame or between lead conductor and frame)
- Sound Pressure Level (SPL) Expressed as the value at 1 m from air inlet side
- Operating Temperature Refer to specifications (Non-condensing)
- Storage Temperature -30 °C to +75 °C (Non-condensing)
- Mass Approx. 290 g

Air Flow - Static Pressure Characteristics

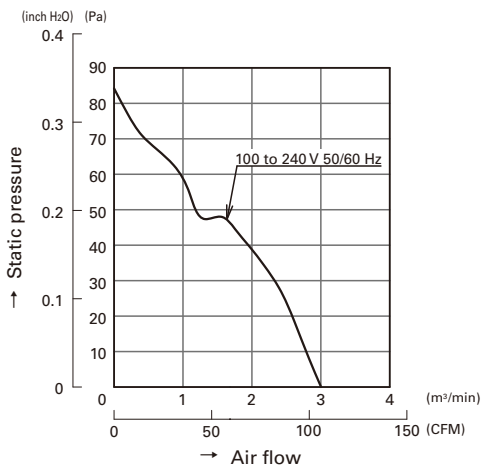

Wiring Diagram

Standard

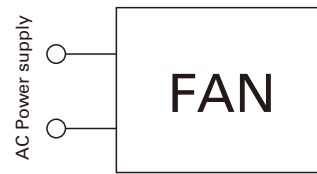

with Sensor

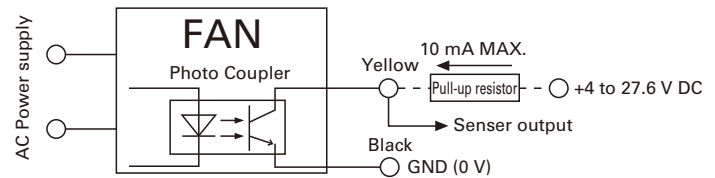

Specifications for Low-speed Sensors

Typical standard model: 9AD1201H1H

Output circuit: Open collector

$V_{CE} = +27.6 \text{ V DC MAX.}$
 $I_C = 10 \text{ mA MAX. [} V_{CE(SAT)} = 1.0 \text{ V MAX.]}$

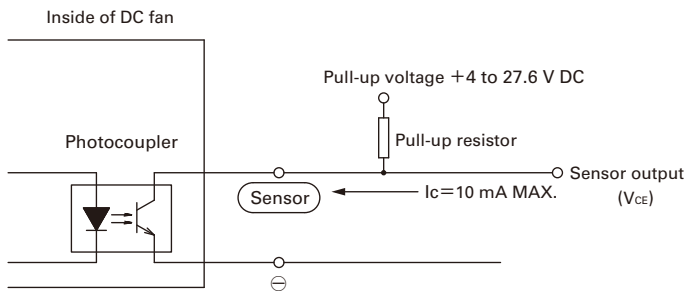

Sensor scheme

Example 1: when steady running

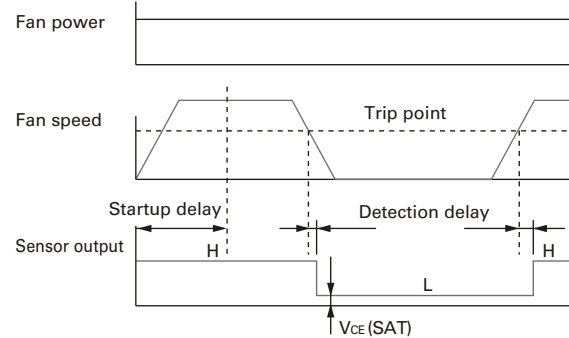

Example 2: when the rotor is locked when the fan motor is turned on and released after the start-up delay time.

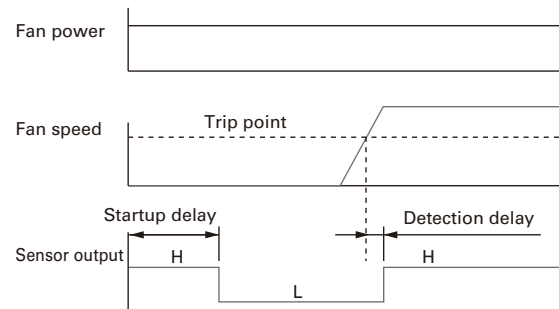

Startup delay: $18 \pm 3 \text{ sec.}$
 Detection delay: 3 sec. MAX.
 Trip point: 1700 min^{-1}

Dimensions (unit : mm) (With ribs)

Standard

4- ϕ 4.3 \pm 0.3
Mounting Hole

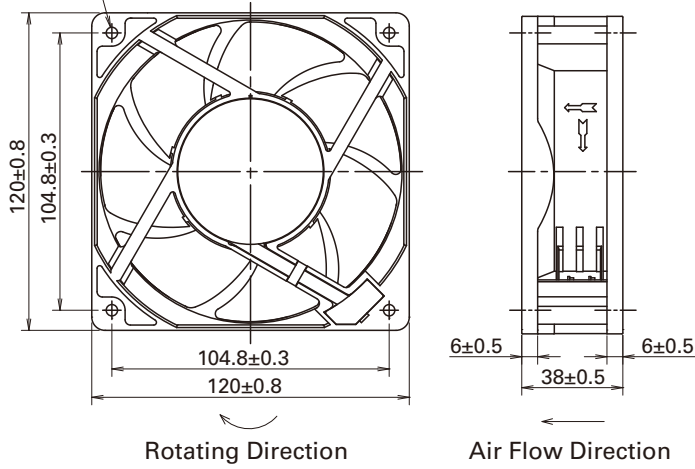

with Sensor

4- ϕ 4.3 \pm 0.3
Mounting Hole

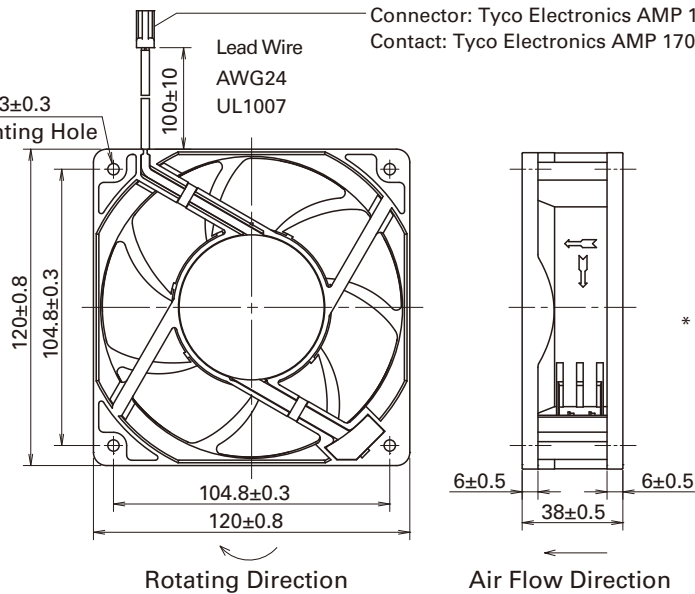

* Recommended connectors and contacts are listed below.
Connector: Tyco Electronics AMP 172211-2
Contact: Tyco Electronics AMP 170376-1

Reference Dimension of Mounting Holes and Vent Opening (unit : mm)

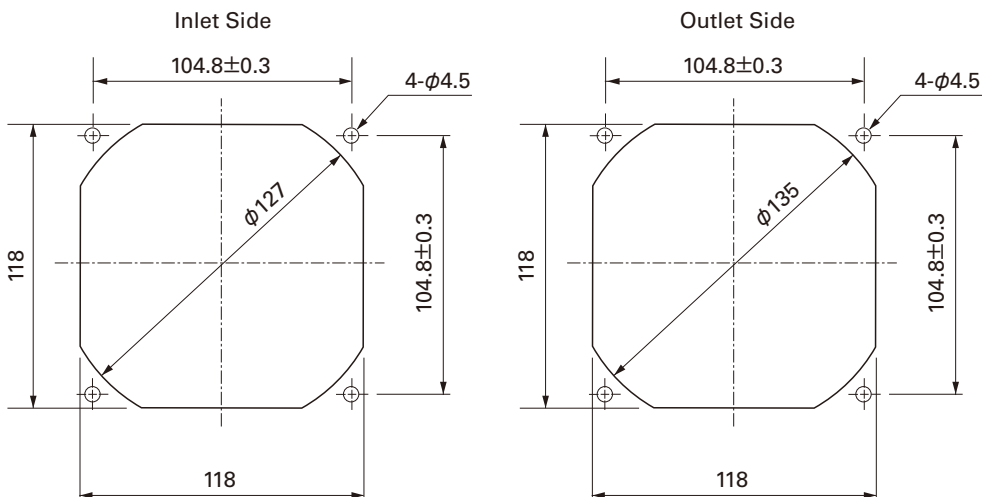

Option

Plug cord

Model: 489-1635-L10, 489-1635-L21

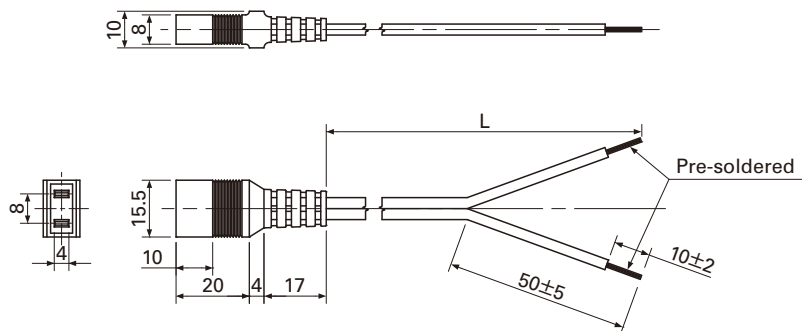

Model	Power cord length (mm)
-L10	1,000
-L21	2,100

Resin filter kits

Model: 109-1000F13 (13PPI), 109-1000F20 (20PPI), 109-1000F30 (30PPI), 109-1000F40 (40PPI)

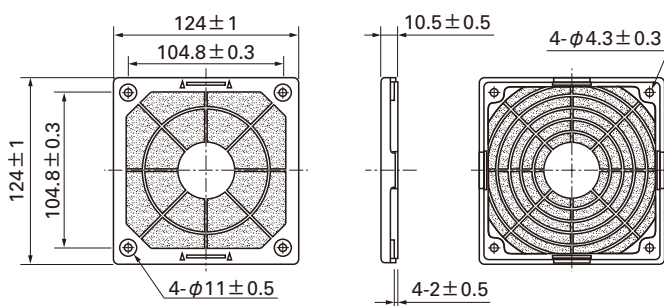

Finger guards

Model: 109-019C Surface treatment: Nickel-chrome plating (silver)
: 109-019H : Cation electropainting (black)

Color

Model: 109-019E Surface treatment: Nickel-chrome plating (silver)
: 109-019K : Cation electropainting (black)

Color

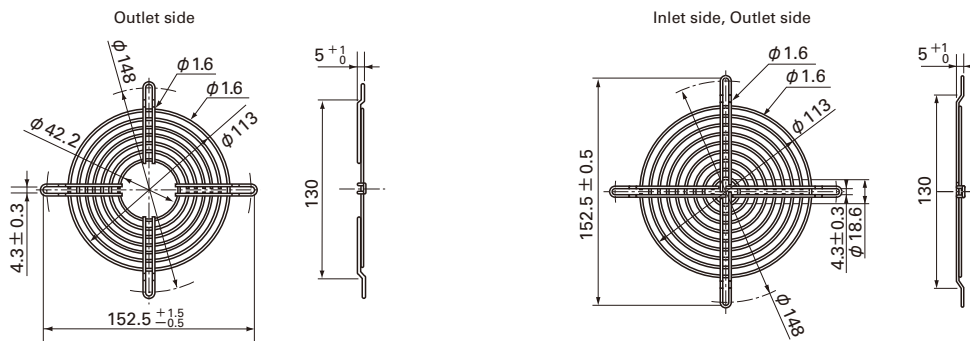

Wiring harness for sensor

Model: 489-1636

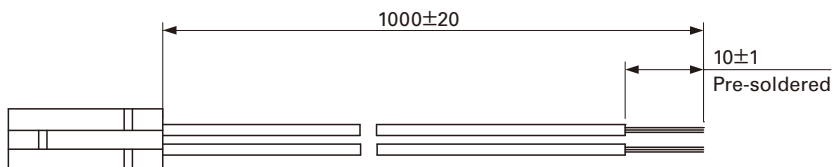

Notice

- The products shown in this catalog are subject to Japanese Export Control Law. Diversion contrary to the law of exporting country is prohibited.
- To protect against electrolytic corrosion that may occur in locations with strong electromagnetic noise, we provide fans that are unaffected by electrolytic corrosion.

SANYO DENKI CO.,LTD. 3-33-1, Minami-Otsuka, Toshima-ku, Tokyo, 170-8451, Japan TEL: +81 3 5927 1020

<http://www.sanyodenki.com>

The names of companies and/or their products specified in this catalog are the trade names, and/or trademarks and/or registered trademarks of such respective companies. "San Ace" is a trademark of SANYO DENKI CO.,LTD.

Specifications are subject to change without notice.

CATALOG No. C1032B001 '13.12