

Thermofit[®] Molded Parts

Specification Control Drawing

Part Number : 234A1XX
 Description : Boot, Rectangular, Subminiature, 90° Side Entry

NOTES

- All dimensions are in $\frac{\text{inches}}{\text{[millimeters]}}$
- Dimensions appearing in table are as follows:
 - a - As Supplied
 - b - After Unrestricted Recovery
- Coating is optional. As supplied dimensions appearing in table are for uncoated parts. When coating is added, entry diameters will be reduced by .06 max.
- Molding ports are optional. When -00 modification number is specified molding ports will be located as shown.

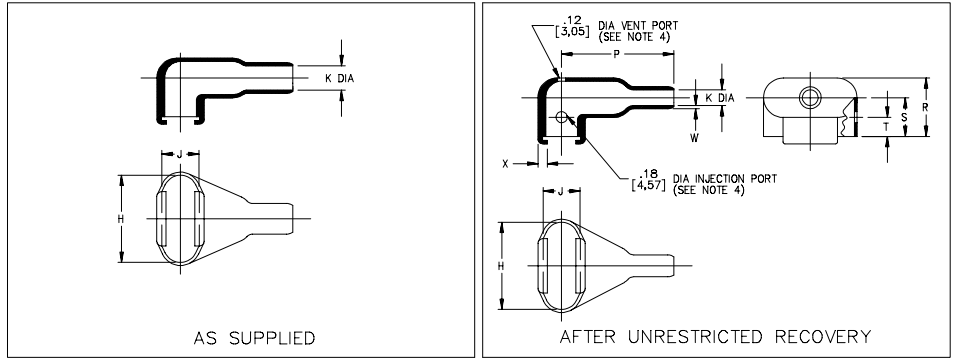

PART NUMBER	H		J		K		P	R	S	T	W	X	This Boot Fits Cannon-Cinch
	±5%	±5%	±5%	±5%	Min	Max	±10%	±10%	±10%	±10%	±20%	±20%	
	a	b	a	b	a	b	b	b	b	b	b	b	
234A111	.80 [20,3]	.80 [20,3]	.42 [10,7]	.42 [10,7]	.31 [7,9]	.16 [4,1]	1.10 [27,9]	.73 [18,5]	.50 [12,7]	.31 [7,87]	.04 [1,02]	.12 [3,05]	DE-9
234A121	1.11 [28,2]	1.11 [28,2]	.42 [10,7]	.42 [10,7]	.40 [10,2]	.21 [5,3]	1.38 [35,1]	.74 [18,8]	.50 [12,7]	.31 [7,87]	.04 [1,02]	.12 [3,05]	DA-15
234A132	1.66 [42,2]	1.66 [42,2]	.42 [10,7]	.42 [10,7]	.55 [14,0]	.25 [6,4]	1.87 [47,5]	.79 [20,1]	.56 [14,2]	.31 [7,87]	.04 [1,02]	.12 [3,05]	DB-25
234A142	2.31 [58,7]	2.31 [58,7]	.42 [10,7]	.42 [10,7]	.68 [17,3]	.31 [7,9]	2.35 [59,7]	.79 [20,1]	.56 [14,2]	.31 [7,87]	.04 [1,02]	.12 [3,05]	DC-37
234A152	2.28 [57,9]	2.28 [57,9]	.54 [13,7]	.54 [13,7]	.75 [19,1]	.36 [9,1]	2.49 [63,2]	1.04 [26,4]	.69 [17,5]	.31 [7,87]	.04 [1,02]	.12 [3,05]	DD-50

Raychem

RAYCHEM CORPORATION
 300 CONSTITUTION DRIVE
 MENLO PARK, CALIFORNIA 94025

Revision : F
 Date : 1/20/94

Part Number : 234A1XX
 Description : Boot, Rectangular, Subminiature, 90° Side Entry

Thermofit[®] Molded Parts

Specification Control Drawing

Part Number : 234A1XX
 Description : Boot, Rectangular, Subminiature, 90° Side Entry

COMPATABILITY CHART					
MATERIAL DASH NO.	MATERIAL DESCRIPTION	RT SPEC	COATING SLASH NO.	COATING S NO.	COATING DESCRIPTION
-3	Polyolefin, Semi-rigid	RT-301	/42;/86	S-1017;S-1048	Adhesive
-4	Polyolefin, Flexible	RT-1304	/42;/86	S-1017;S-1048	Adhesive
-8	Polyolefin Space	RT-1308	N/A		
-12	*VITON, Flexible	RT-1312	N/A		
-25	Elastomer, Fluid Resistant	RT-1325	/86	S-1048	Adhesive
-100	Polyolefin, Semi-flexible ZEROHAL™	RT-1323	/86	S-1048	Adhesive

*VITON is a Registered Trademark of Dupont

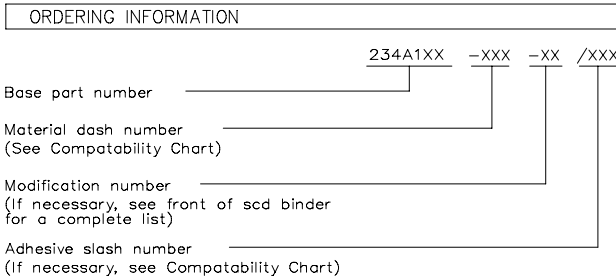

THIS DRAWING IS SUBJECT TO CHANGE WITHOUT NOTICE; CONSULT YOUR NEAREST FIELD REPRESENTATIVE FOR CURRENT REVISION

If this document is printed it becomes uncontrolled.
 Check for the latest revision.

Raychem

RAYCHEM CORPORATION
 300 CONSTITUTION DRIVE
 MENLO PARK, CALIFORNIA 94025

Revision : F
 Date : 1/20/94

Part Number : 234A1XX
 Description : Boot, Rectangular, Subminiature, 90° Side Entry
 CAD FILE MP94012