

SELF CONFIGURING OPTIMISER/COMPENSATOR WITH BOILER SEQUENCE AND HWS CONTROL

DC1100

Specification No. 04-03-105

The DC1100 energy controller is a self configuring optimiser/compensator capable of controlling one or two boilers in sequence with HWS time control. The DC1100 provides the best routines for efficient temperature control in small buildings. It is designed for easy installation and operation in the small/medium commercial property and encompasses the major control requirements of current Building Regulations.

Fundamentally, the controller recognises the application by the sensors that are connected to it, so therefore it is self-configuring. The use of sensible default settings, and a self-adaptive optimiser and compensator, means that the system can be set to work after installation by programming the required temperatures and times. The controller will automatically fine tune, matching the building's requirements. Used either for controlling one boiler or two boilers in sequence with optional automatic weekly rotation, it provides stable control conditions, eliminating boiler short cycling during light load conditions.

All the DC1100's settings are accessible for adjustment, by entering a password. The simplicity does not stop there. Easy access to override the control, either by means of a front panel mounted switch, or by a remote switch unit, allows the heating to be turned on and off without the need to change the settings at the unit. In addition, one outside sensor can pass information to other DC1100s on the same site.

DC1100C

Specification No. 04-03-106

The DC1100C is only available as a replacement for an existing DC1100C controller.



The DC1100C model allows the building to be economically and simply monitored remotely for maintenance and energy management purposes.

Using the well established DC COMMS Estate Management software used by the DC2100C controller, this product can be incorporated into an existing system where this software is already installed.

Connected by a telephone network and modems, access to the current performance of the heating system can be achieved. Historical records of temperature are taken at regular intervals and, perhaps most importantly, alarm information is available so that corrective measures can be taken with minimum delay, perhaps in the event of the boiler failing to fire in the morning. Full access to the controller settings allows alterations to be made via the modem link.

FEATURES

- Self configuring controller
- Self adaptive optimum start
- Self adaptive optimum stop
- Day economy switch off
- Boiler sequence control
- Weekly boiler rotation
- Valve compensation
- Boiler compensation
- Valve/Boiler compensation
- Self-adaptive compensator option
- Adjustable space temperature reset on compensator
- Night set back (space or flow temperature)
- Variable pump overrun
- Hot water time channel
- Multi-stage frost protection
- Valve/Pump summer exercise
- Holiday scheduling
- BST/GMT auto clock change
- Summer/Winter operation
- Front panel selector auto / summer / cont / frost / service
- Remote override facility
- Alarm indicator
- Remote communications capability (DC1100C only)



Data Sheets

DS 1.955 - Theta II & DC Sensors
 DS 3.401 - ALM Actuator
 DS 3.215 - ARM Actuator
 DS 3.005 - AVUM Actuator
 DS 3.201 - RM Actuator
 DS 2.042A - DC1100 Controller Wiring and Commissioning Information
 DS 2.043 - DC1100 Remote Switch Unit



SPECIFICATIONS

Type:	DC1100 Self Configuring Optimiser/Compensator (04-03-105) DC1100C Self Configuring Optimiser/Compensator with remote communications capability (04-03-106)
Power Supply:	230Vac 50Hz
Consumption:	15VA
Fuse:	160mA T 250V
Relay Ratings:	SPNO 3A resistive 1A inductive 230Vac
Ambient Temperature Limits:	0°C to 50°C
Storage Temperature:	-10°C to 60°C
Max: Ambient Humidity:	Up to 95% RH non-condensing
Control Range:	-20°C to 120°C
Accuracy:	± 0.2°C
Resolution:	0.1°C
Weight:	1.2kg
Complies with EC Directives:	EMC, LVD

ACCESSORIES

DC1100 Remote Switch Unit (Part No. 04-03-109)
RB1 Interface Relay (Part No. 03-21-001)

COMPATIBLE DEVICES

Sensors:

A701 Room Temperature (see DS 1.955 for details)
A702 Outside Air Temperature (see DS 1.955 for details)
A703 Immersion Temperature with pocket (see DS 1.955 for details).
A704 Pipe Surface Temperature (Strap-on) (see DS 1.955 for details)

Actuators:

ALM (see DS 3.401 for details)
ARM (see DS 3.215 for details)
AVUM (see DS 3.005 for details)
RM (see DS 3.201 for details)

CONSTRUCTION

Case:	Plastic with transparent perspex lid
Protection Class:	IP 40
Conduit Entries:	20.5mm knock-out cable entries
Indication:	LCD Panel providing continuous information on the DC1100 control status. Displays current date and time, one of the system temperatures and the current control action. The LCD can be used to view alarms, and in SET programming mode, the LCD is used to display setting information. A column of LEDs indicate the status of the controller, including alarms.
Mounting:	Panel or wall mounting. Panel cut-out 186mm x 137mm with a depth clearance of 87mm at the rear.

INPUTS

Outside air temperature
Boiler return sensor
Boiler flow sensor
Space sensors (2 max.)
Digital input to provide for controller override

OUTPUTS

Boiler No. 1
Boiler No. 2
Pump
Valve open
Valve close
Hot water

LCD DISPLAY

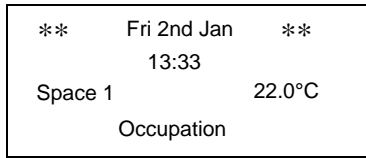

A large front panel display normally shows the time, date, a selected temperature and the current operating status. It is also used to view alarms and change settings.

Four keys (Up, Down, Exit and Enter) adjacent to the display are used to change settings within the controller. These are used when the front panel selector switch is set to SET.

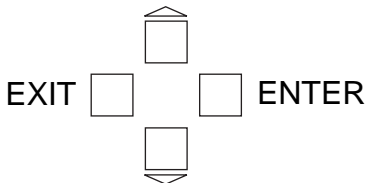

FRONT PANEL SWITCH

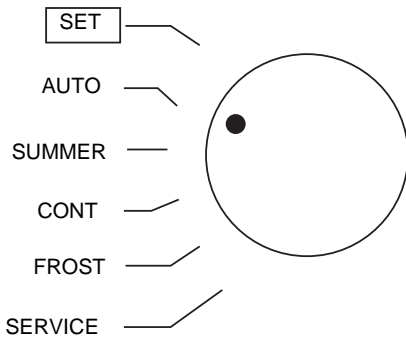

The front panel switch allows control selection. This ranges from normal automatic control of heating and hot water to summer operation of hot water only, constant heating, frost protection only and a set position to change times and temperatures. A service mode allows for plant maintenance without alteration of controller settings.

LED INDICATORS

Six LEDs indicate which functions are on, clearly showing the controller's status, and a seventh LED displays a number of operating faults:

- Boiler 1
- Boiler 2
- Pump
- Valve open
- Valve close
- Hot water
- Alarm

REMOTE SWITCH UNIT (Part No. 04-03-109)

The Remote Switch Unit provides a means of overriding the normal control of the controller by switching the controller into one of four modes (AUTO, SUMMER, HEATING ON, HOLIDAY).

This is a repeat of the function on the controller front panel switch, but allows remote operation from some convenient location.

The override switch is operable only when the controller front panel switch is in the AUTO position.

SCHEMATIC TERMINAL DETAILS

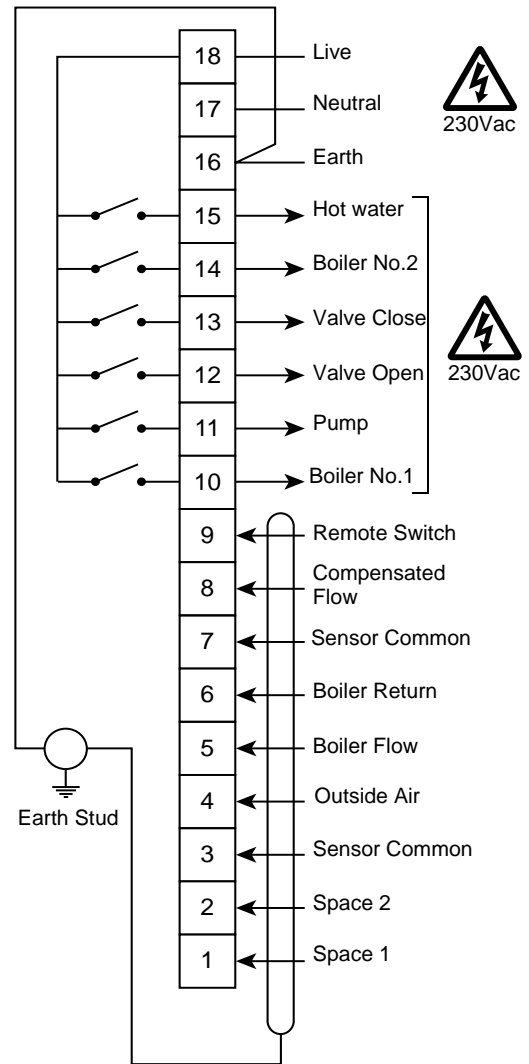

Input Wiring:
Screened Twisted Pair, Screen Earthed at Stud only.



WARNING - ELECTRICAL SHOCK HAZARD.

THIS CONTROLLER OPERATES FROM A 230Vac MAINS SUPPLY AND PROVIDES SWITCHED 230Vac OUTPUTS. ALWAYS ISOLATE THE MAINS SUPPLY FROM THE UNIT BEFORE REMOVING THE CONTROLLER FROM THE WIRING BASE.

TYPICAL APPLICATION DETAIL

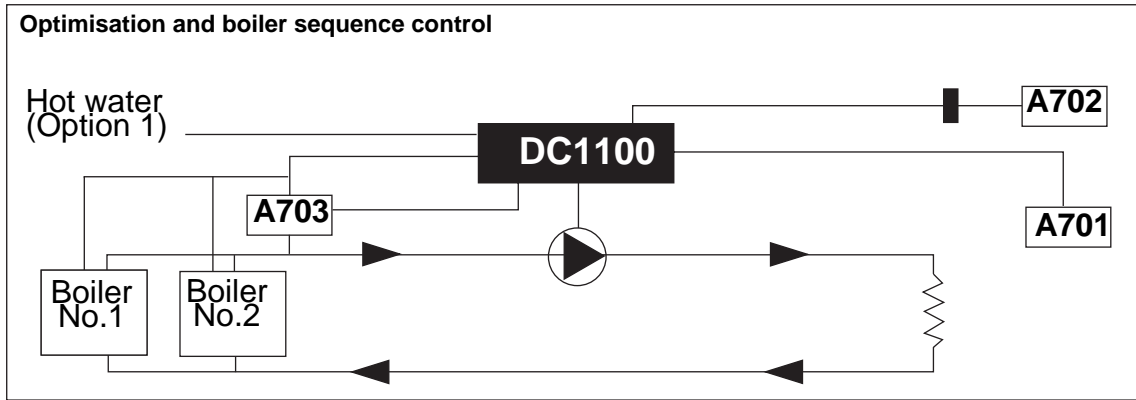

Equipment Schedule

DC1100 controller
 A701 Space sensor
 A702 Outside sensor
 A703 Boiler flow sensor

DC1100

Features

Self adaptive optimum start
 Optimum stop
 Day economy
 Boiler sequence control
 Weekly boiler rotation
 Pump overrun
 2 Stage frost protection
 Pump exercise routine
 Holiday scheduling
 BST/GMT auto clock change
 Summer/Winter selection
 Alarms

Options

1. Fixed time start of HWS - see hot water applications (DS 2.042A)
2. Remote Auto/Summer/Heating On/Holiday selection switch
3. Additional Space sensor for averaging
4. Boiler return sensor for frost protection
5. A704 Strap on sensor available as an alternative to the A703 Immersion sensor

Controller Connection Detail

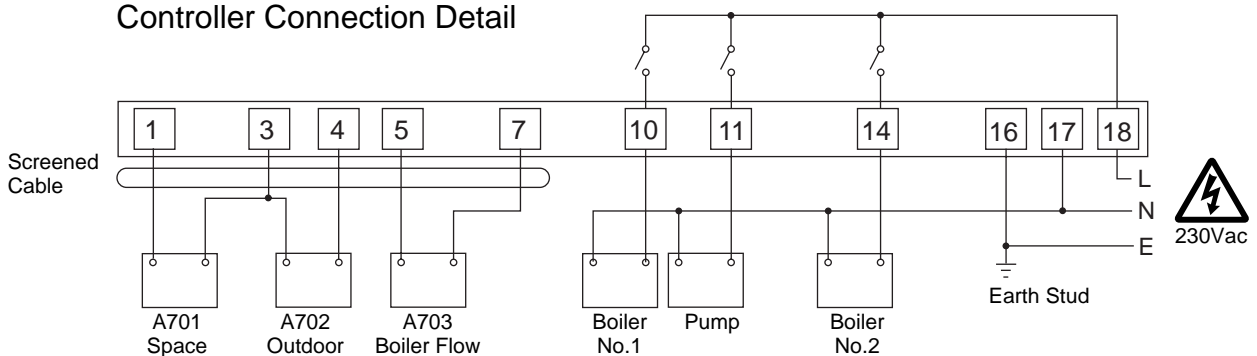

Sensor Screen Connections omitted for clarity

WARNING - SEE SCHEMATIC DETAILS

Note: Auxiliary relays/starters may be required if switching currents exceed 3A resistive, 1A inductive.

Refer to DS 2.042A for other applications.



WARNING - ELECTRICAL SHOCK HAZARD.
 THIS CONTROLLER OPERATES FROM A 230V_{ac} MAINS SUPPLY AND PROVIDES SWITCHED 230V_{ac} OUTPUTS. ALWAYS ISOLATE THE MAINS SUPPLY FROM THE UNIT BEFORE REMOVING THE CONTROLLER FROM THE WIRING BASE.

DIMENSION DETAILS

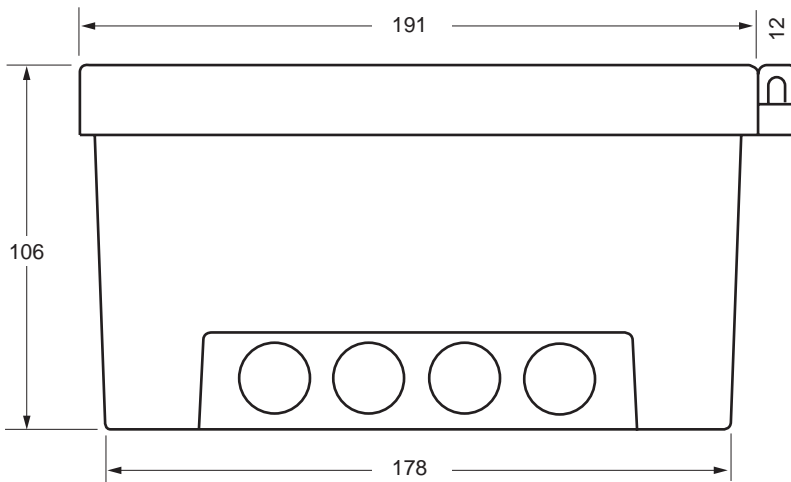
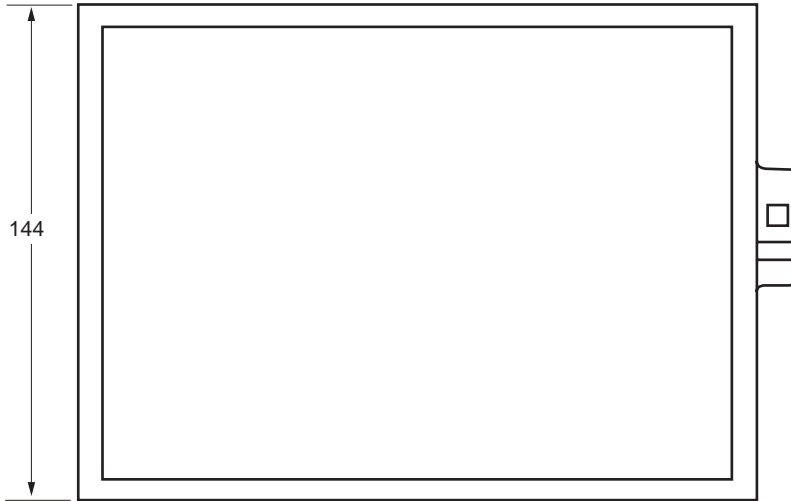

Dimensions in mm

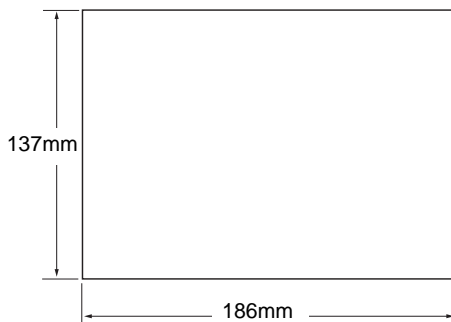

Panel Cut-out details.
Allow 87mm depth.



WARNINGS - ELECTRICAL SHOCK HAZARDS.

THIS CONTROLLER OPERATES FROM A 230Vac MAINS SUPPLY AND PROVIDES SWITCHED 230Vac OUTPUTS. ALWAYS ISOLATE THE MAINS SUPPLY FROM THE UNIT BEFORE REMOVING THE CONTROLLER FROM THE WIRING BASE.

WARNING - THIS PRODUCT CONTAINS A NICKEL-METAL HYDRIDE BATTERY WHICH IS COMPLETELY SAFE WHILST IN NORMAL USE. THE BATTERY MUST BE DISPOSED OF IN AN AUTHORISED LANDFILL SITE.

Cautions

- Do not apply any mains or other voltages until the wiring is complete and has been checked by a qualified technician.
- If any equipment covers have to be removed during the installation of this equipment, ensure that they are refitted after installation to comply with UL and CE safety requirements.
- Do not exceed maximum ambient temperature.
- Interference with parts under sealed covers invalidates guarantee.
- Design and performance of TAC Satchwell equipment is subject to improvement and therefore liable to alteration without notice.
- Information is given for guidance only and TAC Satchwell does not accept responsibility for the selection and installation of its products unless information has been given by the Company in writing relating to a specific application.
- A periodic system and tuning check of the control system is recommended. Please contact your local sales office for details.

Copyright © 2005, TAC AB
All brand names, trademarks and registered trademarks are the property of their respective owners. Information contained within this document is subject to change without notice. All rights reserved.

DS 2.042 12/05



TAC Headquarters
Malmö, Sweden
+46 40 38 68 50

Satchwell Helpline
+44 (0) 1753 611000
satchwell.info@uk.tac.com

www.tac.com

