

Surge protection plug - CTM 2X1- 24DC - 2838500

Please be informed that the data shown in this PDF Document is generated from our Online Catalog. Please find the complete data in the user's documentation. Our General Terms of Use for Downloads are valid (<http://phoenixcontact.com/download>)



LSA-PLUS plug (COMTRAB CTM) with protective circuit for 2-conductor signal circuits grounded on one side.
Nominal voltage: 24 V DC

Why buy this product

- The CTM 10-MAG surge protection magazine can be freely fitted with various protective plugs
- Can be used in LSA-PLUS disconnect and control strips or CT-TERMIBLOCK
- Typical installation locations include marshalling distributors
- Space-saving LSA-PLUS connection technology
- Modular compact protection for high-density networks



Key commercial data

Packing unit	10 pc
GTIN	 4 017918 819538
Weight per Piece (excluding packing)	10.38 g
Custom tariff number	85363010
Country of origin	Germany

Technical data

Dimensions

Height	21 mm
Width	9.5 mm
Depth	53.5 mm

Ambient conditions

Ambient temperature (operation)	-25 °C ... 75 °C
Degree of protection	IP20

General

Housing material	PA
------------------	----

Surge protection plug - CTM 2X1- 24DC - 2838500

Technical data

General

Inflammability class according to UL 94	V0
Color	black
Standards for clearances and creepage distances	DIN VDE 0110-1
	IEC 60664-1
Surge voltage category	II
Pollution degree	2
Mounting type	On CT-TERMIBLOCK and LSA-PLUS disconnect strip
Type	LSA-PLUS module
Number of positions	2
Direction of action	Line-Line & Line-Earth Ground
Arrester can be tested with CHECKMASTER from software version:	From SW rev. 1.10

Protective circuit

IEC test classification	B2
	C1
	C2
	C3
	D1
VDE requirement class	B2
	C1
	C2
	C3
	D1
Nominal voltage U_N	24 V DC
Maximum continuous operating voltage U_C	± 30 V DC
	21 V AC
Maximum continuous voltage U_C (wire-ground)	± 30 V DC
	21 V AC
Nominal current I_N	380 mA (25 °C)
Operating effective current I_C at U_C	≤ 5 μ A
Residual current I_{PE}	≤ 2 μ A
Nominal discharge current I_n (8/20) μ s (Core-Earth)	5 kA
Total surge current (8/20) μ s	10 kA
Total surge current (10/350) μ s	2.5 kA
Max. discharge current I_{max} (8/20) μ s maximum (Core-Earth)	10 kA (in total)
Nominal pulse current I_{an} (10/1000) μ s (Core-Earth)	100 A
Impulse discharge current (10/350) μ s, peak value I_{imp}	1 kA
Output voltage limitation at 1 kV/ μ s (Core-Earth) spike	55 V
Output voltage limitation at 1 kV/ μ s (Core-Earth) static	≤ 45 V
Residual voltage at I_n , (conductor-ground)	≤ 50 V
Residual voltage with I_{an} (10/1000) μ s (conductor-ground)	≤ 15 V

Surge protection plug - CTM 2X1- 24DC - 2838500

Technical data

Protective circuit

Voltage protection level U_p (core-ground)	≤ 100 V (C2 - 10 kV/5 kA, spike)
	≤ 45 V (C2 - 10 kV/5 kA, static)
	≤ 45 V (C3, 7.5 kV/100 A, spike)
	≤ 15 V (C3, 7.5 kV/100 A, static)
Response time t_A (Core-Earth)	≤ 1 ns
Input attenuation a_E , asym.	0.3 dB (≤ 700 kHz)
Cut-off frequency f_g (3 dB), asym. (PE) in 100 Ohm system	2.7 MHz
Capacity (Core-Earth)	1.2 nF ($f=1$ MHz / $V_R=0$ V)
Resistance in series	3.3 Ω 10 %
	3.3 Ω
Surge protection fault message	None
Impulse durability (conductor-ground)	C2 (4 kV / 2 kA)
	C3 - 100 A
	B2 - 4 kV/100 A
	D1 - 1 kA
Alternating current carrying capacity (conductor-ground)	5 A - 1 s

Connection data

Connection method	can be plugged into COMTRAB-TERMIBLOCK and LSA-PLUS disconnect and switching strips
Connection type IN	COMTRAB plug-in system
Connection type OUT	COMTRAB plug-in system
Connection method	LSA-PLUS

Connection, equipotential bonding

Connection method	Spring contact
-------------------	----------------

Standards and Regulations

Standards/regulations	IEC 61643-21
-----------------------	--------------

Classifications

eCl@ss

eCl@ss 4.0	27140201
eCl@ss 4.1	27130801
eCl@ss 5.0	27130801
eCl@ss 5.1	27130801
eCl@ss 6.0	27130807
eCl@ss 7.0	27130807
eCl@ss 8.0	27130807

ETIM

ETIM 2.0	EC000943
----------	----------

Surge protection plug - CTM 2X1- 24DC - 2838500

Classifications

ETIM

ETIM 3.0	EC000943
ETIM 4.0	EC000943
ETIM 5.0	EC000943

UNSPSC

UNSPSC 6.01	30212010
UNSPSC 7.0901	39121610
UNSPSC 11	39121610
UNSPSC 12.01	39121610
UNSPSC 13.2	39121620

Approvals

Approvals

Approvals

UL Listed / EAC

Ex Approvals

Approvals submitted

Approval details

UL Listed 

EAC

Accessories

Necessary add-on products

Disconnect strip - CT 10-TL - 2765356



LSA-PLUS disconnect strip to hold the CTM and CT 10 protection modules. Version: 10 double conductors, dimension A: 124 mm.

Surge protection plug - CTM 2X1- 24DC - 2838500

Accessories

Grounding rail - CT 1-10-ES - 2765547



Ground rail for CTM protective plug when used in combination with LSA-PLUS disconnect strip. Version: 10 double conductors

Screw termination block - CT-TERMIBLOCK 10 DA - 0441711



Screw termination block with disconnect contacts for accommodating protective plugs CT and CTM. Use in MCR and telecommunications systems. Design: 10 double wires

Magazine - CTM 10-MAG - 2838610



Magazine with a grounding rail to accommodate up to 10 LSA-PLUS protective plugs (COMTRAB CTM), to insert in CT-TERMIBLOCK or LSA-PLUS disconnect strip

Additional products

Mounting clip - CT 10-MB/ 3 - 2765372



Mounting clip, for holding 3 disconnect or ground wire strips. Version: 10 double conductors, dimensions: A 104.5 mm, B 65 mm.

Mounting clip - CT 10-MB/10 - 2765385



Mounting clip, for holding 10 disconnect or ground wire strips. Version: 10 double conductors, dimensions: A 104.5 mm, dimensions B 245.5 mm

Surge protection plug - CTM 2X1- 24DC - 2838500

Accessories

Cable feed-through sleeve - CT-KDT - 2765518



Cable bush for assembly troughs, for protection of the lines guided through the laminated frame

Short-circuit connector - CTM EST - 2838649



LSA-PLUS grounding plug (COMTRAB CTM) to short-circuit and ground potentials in CT-TERMIBLOCK... and disconnect strip CT 10...

Shield connection - SSA 3-6 - 2839295



shield fast connections for conductor diameter 3 - 6 mm. Potential connection cable: 200 mm, black

Shield connection - SSA 5-10 - 2839512



Shield fast connection for conductor diameters 5 - 10 mm. Potential connection cable: 200 mm, black

Drawings

Surge protection plug - CTM 2X1- 24DC - 2838500

Dimensioned drawing

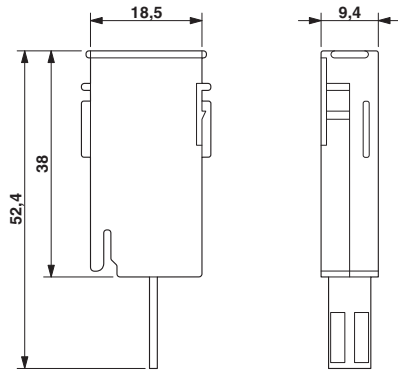

Circuit diagram

