

# DREMEL®

*Tools for the Imagination™*

General trade catalogue 1999



## TABLE OF CONTENTS

Multi Shape Sander	2-3
Dremel Multi	4-5
Dremel Multi Cordless	6
Dremel Multi Purpose	7
Dremel Multi Attachments	8
Accessory sets	9
Accessories	10-13
1371 moto scroller	14
1731 moto sander	15

Inside this catalogue you will find  
a complete selection of Dremel tools,  
accessories and attachments.

# Multi Shape Sander

- Eliminates all hand sanding on shaped and difficult to reach surfaces
- In-line sanding action gives perfect finish
- Easy to use due to lightweight and compact design

With a wide variety of shapes and variable speeds, the Dremel Multi Shape Sander provides ultra-smooth results on a multitude of surfaces and materials. Use it to sand deep grooves, intricate carvings, curved moldings, thin slats, and more. The Dremel Multi Shape Sander has the power and precision to get even the toughest sanding jobs done quickly and easily.

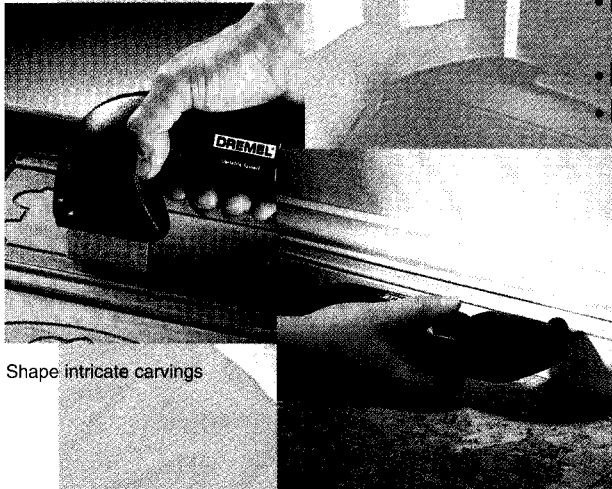

Shape intricate carvings

Detail curved moldings

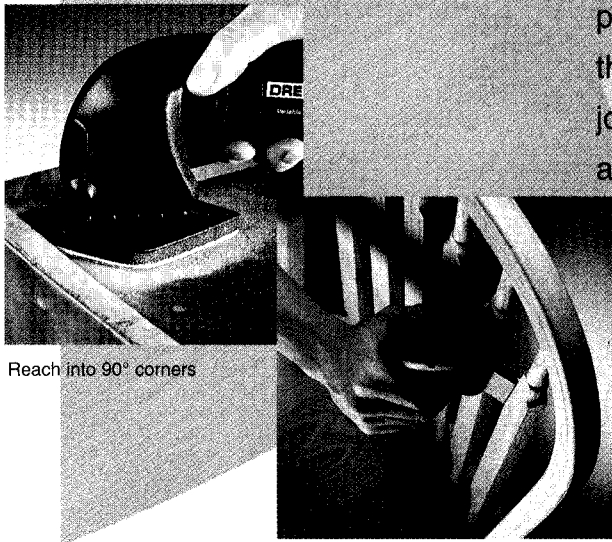

Reach into 90° corners

Sand sharp corners

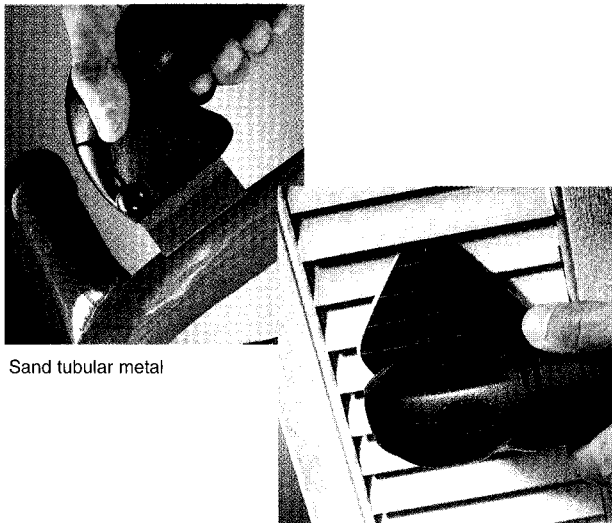

Sand tubular metal

Sand thin slats

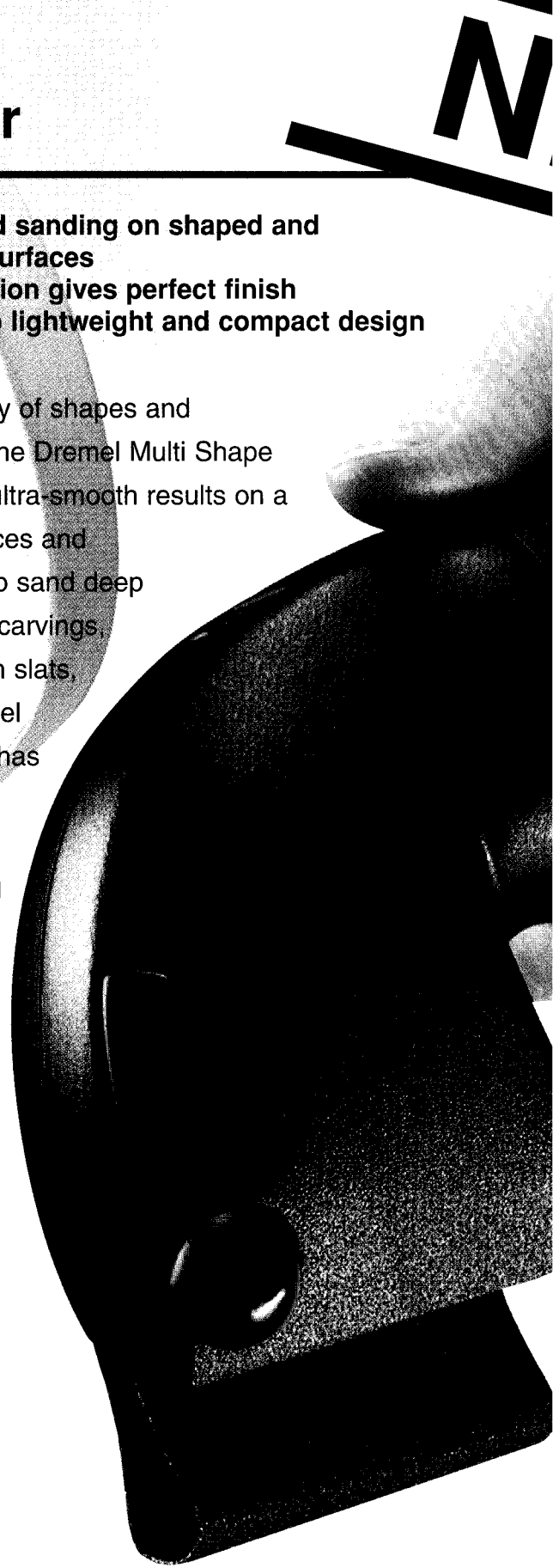

## Model 6000 Technical specifications

Input: ..... 110 Watts  
Weight: ..... 590 gr  
Length: ..... 215 mm  
Strokes pm: ..... 8,000-18,000  
Stroke length: ..... 1,5 mm  
Volts: ..... 230V  
Action: ..... In-line, reciprocating

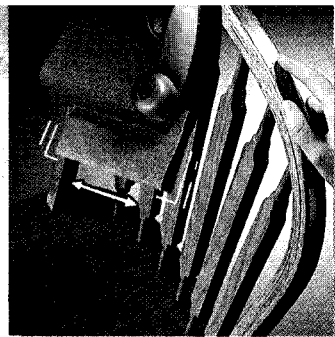

Perfect finish due to in-line sanding action

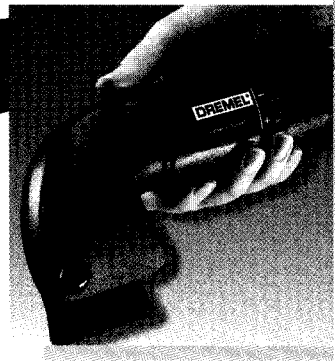

Lightweight and compact design

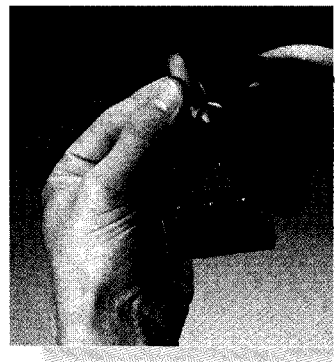

Exclusive quick change accessory release



Long-lasting reusable sanding tubes

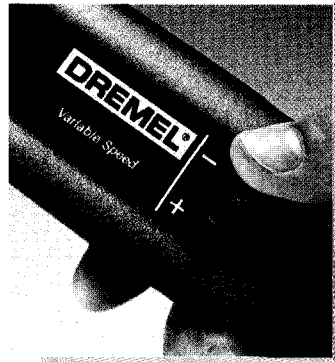

8,000-18,000 variable strokes per minute

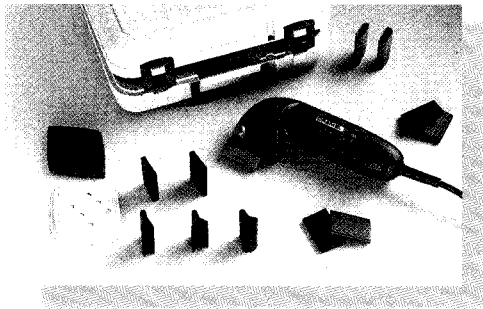

### Multi Shape Sander Model 6000

Includes:

- Variable speed tool
- 10 sanding shapes
- 1 detail sanding pad
- 3 sanding tubes
- 3 sheets of hook & loop paper
- Instruction manual
- Convenient storage case

### Optional Multi Shape Sander Accessories:

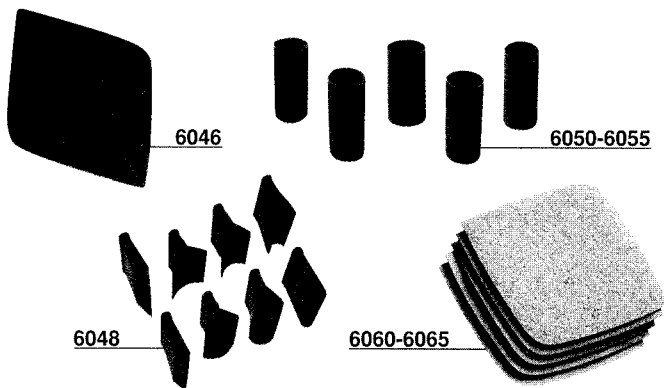

Model	Description
6046	Shutter/extension pad
6048	8 Pc. Shape set
6010	18 Pc Shape set
6050	Sanding Tubes: 80 grit
6051	100 grit
6052	120 grit
6053	150 grit
6054	220 grit
6055	80/120/220 grit
6060	Hook and Loop paper: 80 grit
6061	120 grit
6062	220 grit
6063	100 grit
6064	150 grit
6065	80/120/220 grit

# Multi

The DREMEL Multi is the ideal tool to tackle a wide range of the smaller DIY and craft jobs in and around the house.

The DREMEL Multi is comfortable and lightweight and therefore easy to use with just one hand. It has countless uses with all

materials, because of its extremely high speed of up to 33,000 RPM. With over 100 accessories and attachments the applications of the DREMEL Multi are endless. The amazing DREMEL Multi will be the answer to the DIY prayers of every craftsman and DIY enthusiast.

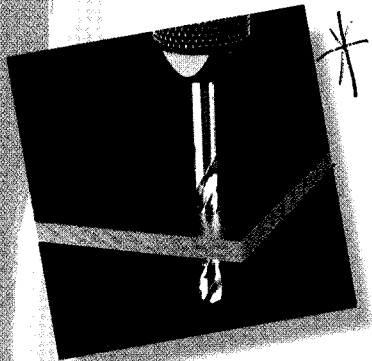

*drills...*

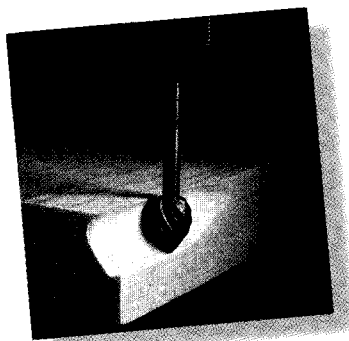

*routs...*

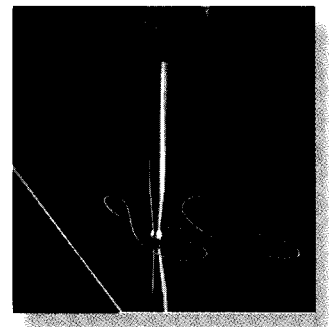

*carves...*



*cuts...*

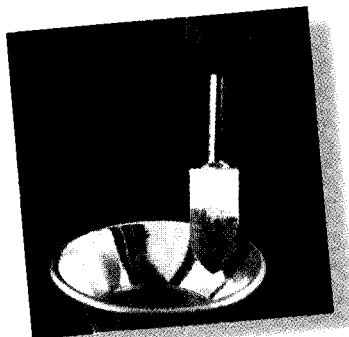

*polishes...*

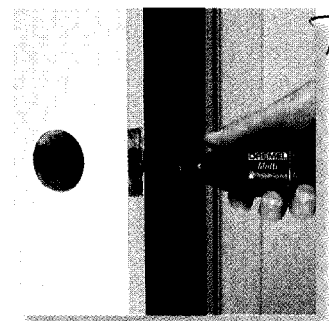

*makes holes...*

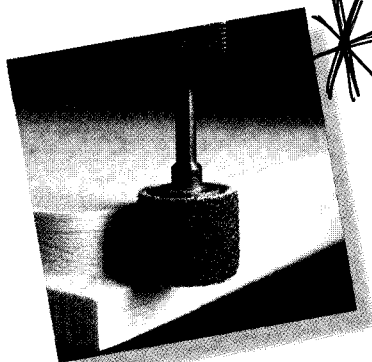

*sands...*

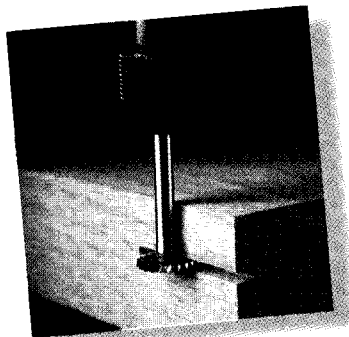

*grooves...*



*and cuts tiles...*

**More versatile than a Swiss army knife.**

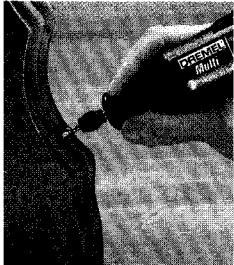

*It shapes...*



*and sharpens...*



**Dremel Multi Model 395**

- as model 3950, only with
- 15 accessories
- Storage case not included

**Dremel Multi Model 3950 Kit**

- 40 Accessories
- Quick Change Collet Nut
- 230 Volts, no transformer needed
- High speed (10.000-33.000 RPM)
- Powerful motor
- Light and compact, easy to handle
- Shaft lock
- Hanger
- Dual ballbearing shaft
- Precisely centered 3,2 & 2,4 mm chuck collet
- Additional collets of 0,8/1,6 mm available
- Double insulated and radio/tv suppressed
- Includes wrench for chuck collet
- Extensive assortment of attachments and accessories available
- A convenient storage case



**Model 395/3950  
Technical specifications**

Input: .....	125 Watts
Weight: .....	0,45 kg
No load speed: .....	10.000-33.000 RPM
Capacity collet: .....	0,8 - 3,2 mm

*For accessories see pages 8 through 13.*



# Cordless Multi

## 7,2V Cordless Multi Kit model 7701

High precision cordless tool for multi-purpose use  
Includes:

- 2 speed (7.500/15.000 RPM)
- 80-minute battery charger with LED charging indicator assuring battery is being charged
- Precisely centered 3,2 mm collet.
- Additional collets of 0,8/1,6/2,4 mm available
- Includes No. 757 Power Pack
- Powerful motor
- Light and compact, easy to handle
- Ball bearing drive shaft
- Shaft lock

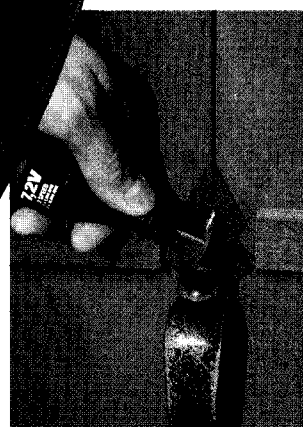
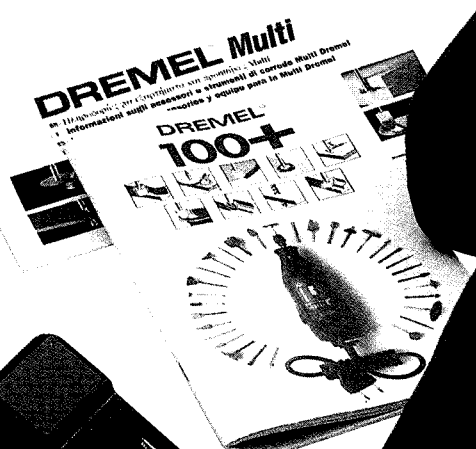
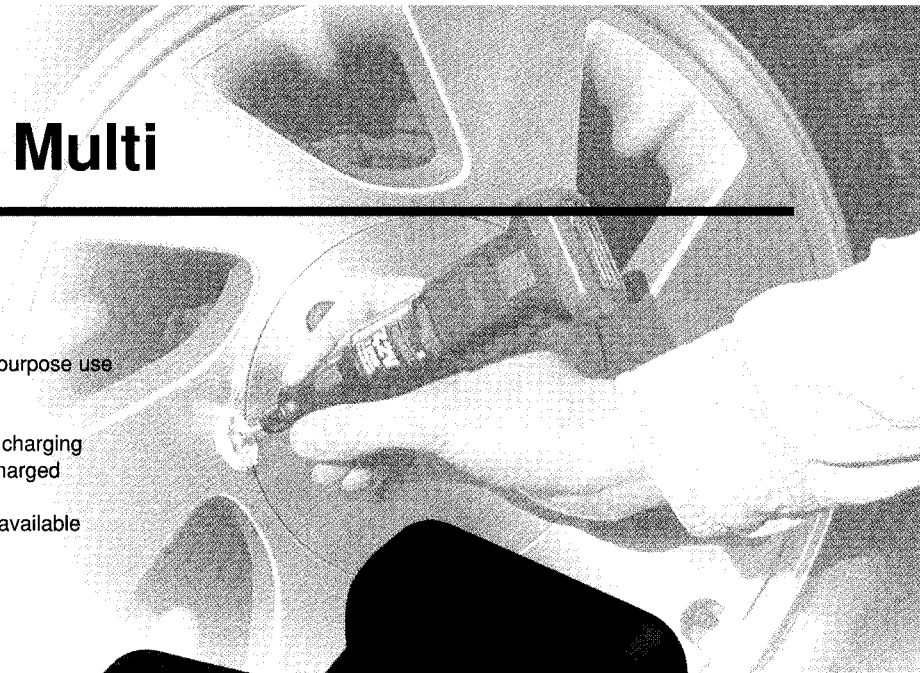

### Model 7701 Technical specifications

No load speed	7.500/15.000 RPM
Volts	7,2
Charging Time	.80 minutes
Capacity collet	.3,2 mm
Weight	.0.27 kg

### 7,2V Power Pack model 757

- Removable, rechargeable battery pack for continuous use

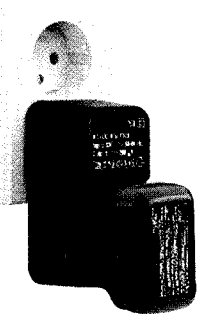

### 6V Cordless Engraver model 752

Engraving for metal, wood and glass materials

Includes:

- 2,4 and 3,2 mm Collets
  - No. 7103 Diamond Point
  - Battery Holder
- (Alkaline batteries not included)

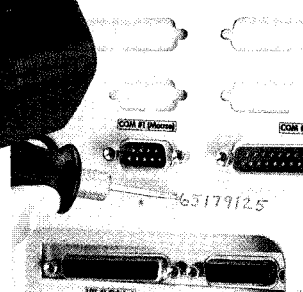

# Multi Purpose Flex Shaft Tool

## Multi Purpose Flex Shaft Tool kit model 7360

- Professional quality
- Heavy duty 250 Watts motor
- High max. speed (max. 22.000 RPM)
- Footswitch with speed control (1.000 - 22.000 RPM)
- 113 cm flex shaft
- Double ball bearing handpiece model 236, with 3,0 - 3,2 mm and 6,0 - 6,4 mm collets
- Double insulated and radio/tv suppressed
- 26 pieces accessory set
- Maintenance kit
- Wall bracket and hang hook
- Accessory organizer for easy accessory storage
- Wrench and pin for changing bits
- 230 Volts

## Model 7360 Technical specifications

Input ..... 250 W  
No load speed. .... 1.000 - 22.000 RPM  
Shaft length ..... 1130 mm

## Precision handpiece model 235

- Accepts bits with 3,2 mm shank or less
- Includes: 2,4 and 3,2 mm collets and wrench for changing bits
- Lightweight 13 mm diameter housing and sealed ball bearing make this a smooth and cool running handpiece
- Small diameter allows pencil type grip for intricate detail carving, grinding and polishing
- Length 11,4 cm

## Heavy duty handpiece model 236

- Double ball bearing construction
- Includes 3,0 - 3,2 mm and 6,0 - 6,4 mm collets, wrench and pin for changing bits
- Accepts 2,4 - 6,4 mm collets and bits
- Length 13,3 cm

## Multi-purpose handpiece model 237

- Accepts collets and bits 3,2 mm or less.
- Includes 2,4 mm and 3,2 mm collets and wrench.
- Ball bearing construction for long life and smooth, cool running
- Length 11,4 cm

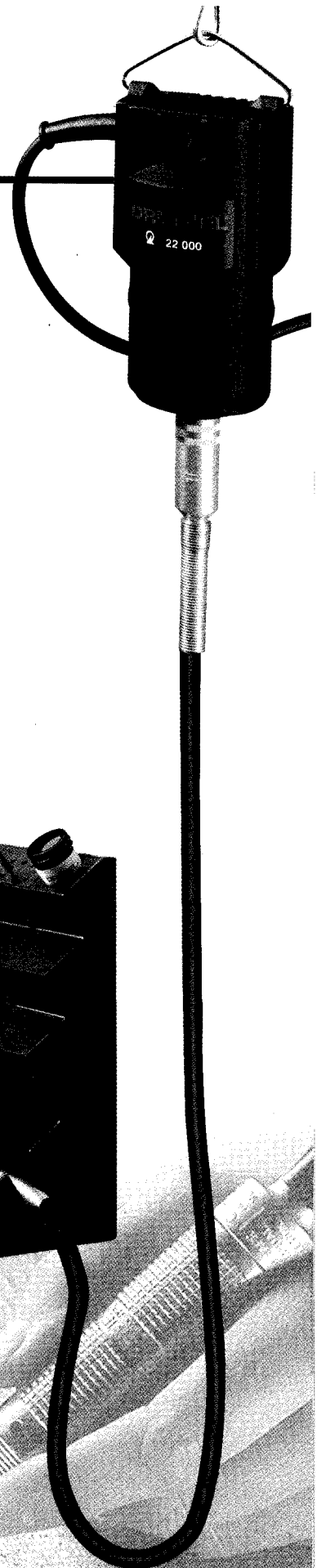

# Multi Attachments (for use with 395/3950 only)

212

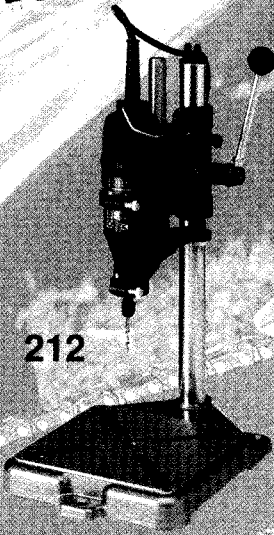

## Drill stand model 212

- Precise drilling, routing, grooving
- Throat depth 115 mm
- Large worktable (155 x 155 mm) with slots for mounting the work-piece
- Max. travel 70 mm

## Router attachment model 230

- Converts Dremel Tool into a versatile router
- Removable edge guide for freehand routing
- Suitable for routing circles
- Adjustable depth

230

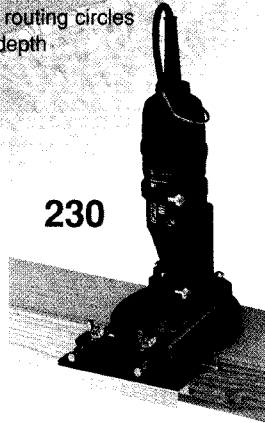

## Router table model 231

- Converts Dremel Multi into a stationary router
- Easy to mount on workbench
- Router bit guard with view cylinder
- Adjustable ripfence
- Large worktable (200 x 150 mm)

231

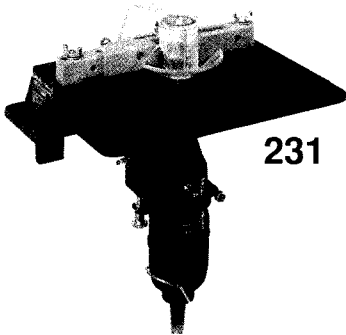

## D-vise model 2214

- Vise head, post and adjustable base
- Vise swivels 360°
- Tilts 180° all directions

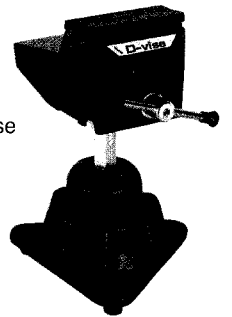

1453

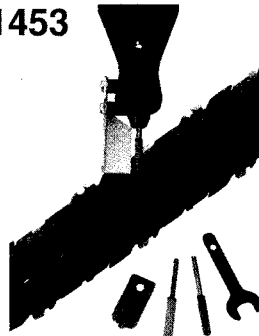

## Chainsaw sharpening attachment model 1453

- Easily sharpen the dulllest of blades with this attachment
- Use with model 395(0)

## Tool holder model 2217

- Tool holder and base for model 395

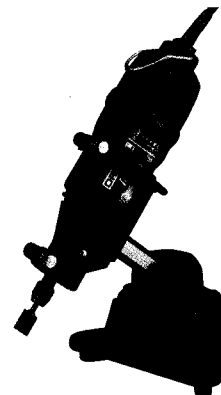

## Tile, plasterboard and wood cutting attachment

An intelligent attachment which solves once-and-for-all the age-old problem faced by all DIY enthusiasts and craftsmen: "How do you cut precise holes in sealed surfaces?" This attachment makes it possible: now, precise cutouts (for pipes, etc.) can be created in even the hardest tiles - or in wood, plasterboard and many more materials.

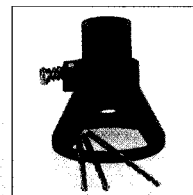

### Plasterboard and wood cutting kit 565

(with 2 plasterboard cutters and 1 spiral cutter) Cuts fibreglass, wood and plasterboard easily.

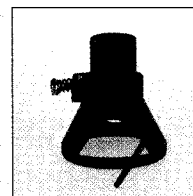

### Ceramic tile cutting kit 566

(with 1 tile cutter) Cuts ceramic wall tile to any shape.



# Multi Accessory Sets

## 10 Pc. Cleaning/Polishing set model 604

Qty.	Description
1	461 Rubber Polishing Wheel
1	428 Wire Brush
2	414, 429 Felt Polishing Wheels
1	404 Bristle Brush
1	422 Felt Polishing Tip
2	401, 402 Mandrels
1	423 Cloth Polishing Wheel
1	421 Polishing Compound



## 16 Pc. Cleaning/Polishing set model 624

Qty.	Description
2	461, 465 Rubber Polishing Wheels
4	414, 429 Felt Polishing Wheels
1	422 Felt Polishing Tip
1	425 Emery Polishing Wheel
1	423 Cloth Polishing Wheel
2	428, 443 Wire Brushes
2	404, 405 Bristle Brushes
2	401, 402 Mandrels
1	421 Polishing Compound



## 20 Pc. Cutting/Carving set model 605

Qty.	Description
1	426 Reinforced Cut-off Wheel
12	409 Cut-off Wheels
1	402 Mandrel
1	953 Grinding Stone
1	196 High Speed Cutter
1	107 Engraving Cutter
1	407 Drum Sander
1	408 Coarse Sander Band
1	432 Fine Sander Band

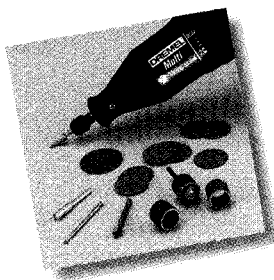

## 30 Pc. Cutting/Carving set model 625

Qty.	Description
2	426 Reinforced Cut-off Wheels
18	409 Cut-off Wheels
1	402 Mandrel
3	192, 194, 196 High Speed Cutters
1	107 Engraving Cutter
1	953 Grinding Stone
1	407 Drum Sander
1	408 Coarse Sander Band
2	432 Fine Sander Bands



## 25 Pc. Sanding/Grinding set model 606

Qty.	Description
4	952, 8193, 84922, 85422 Grinding Stones
1	415 Dressing Stone
1	407 Drum Sander
1	408 Coarse Sander Band
2	432 Fine Sander Bands
1	402 Mandrel
5	411 Coarse Sanding Discs
5	412 Medium Sanding Discs
5	413 Fine Sanding Discs



## 44 Pc. Sanding/Grinding set model 626

Qty.	Description
8	911, 952, 953, 8193, 83142, 83702, 84922, 85422 Grinding Stones
1	415 Dressing Stone
1	407 Drum Sander
1	408 Coarse Sander Band
2	432 Fine Sander Bands
1	402 Mandrel
10	411 Coarse Sanding Discs
10	412 Medium Sanding Discs
10	413 Fine Sanding Discs

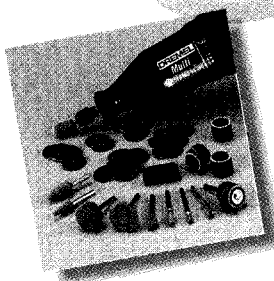

## 30 Pc. General Purpose model no. 607

Qty.	Description
2	952, 8193 Grinding Stones
1	428 Wire Brush
1	429 Felt Polishing Wheel
1	407 Drum Sander
1	408 Coarse Sander Band
2	432 Fine Sander Bands
2	401, 402 Mandrels
20	409 Cut-off Wheels



## 50 Pc. General Purpose model no. 627

Qty.	Description
3	952, 8193, 85422 Grinding Stones
1	415 Dressing Stone
1	428 Wire Brush
1	429 Felt Polishing Wheel
2	191, 194 High Speed Cutters
1	407 Drum Sander
1	408 Coarse Sander Band
2	432 Fine Sander Bands
2	401, 402 Mandrels
36	409 Cut-off Wheels

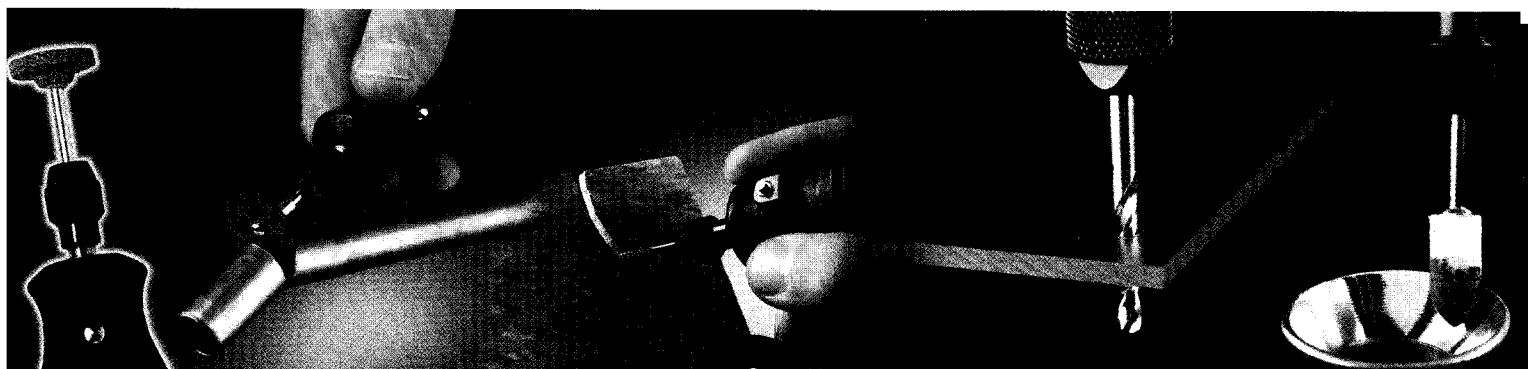



# Multi Accessories

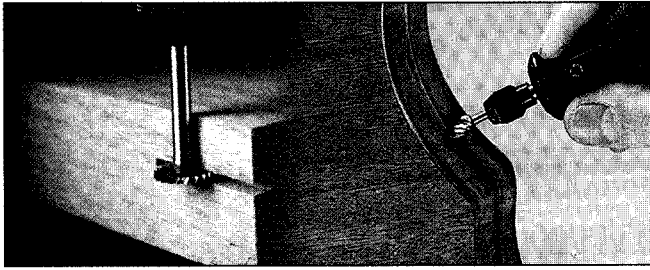

High Speed Cutters

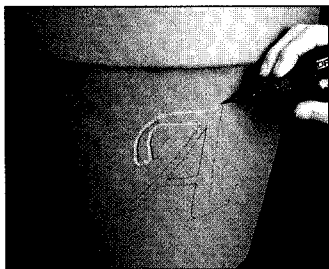
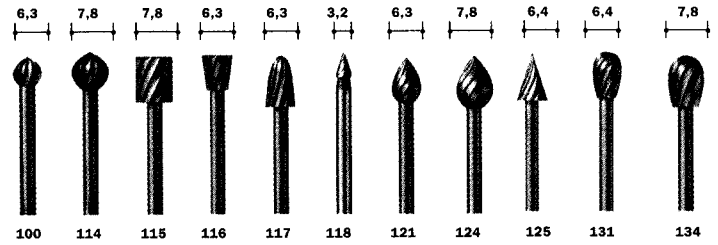

Tungsten carbide cutters

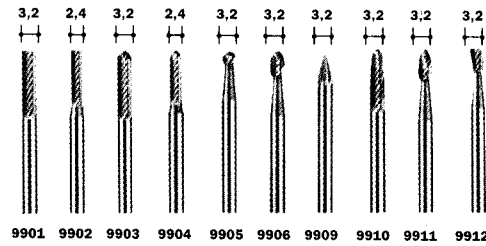

Diamond wheel points



Small engraving cutters

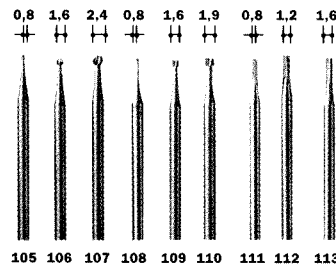

Structured tooth tungsten carbide

## Router bits

610

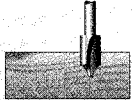

Beading Bit  
Decorative beading work.

612



Piloted Beading Bit  
A decorative bit for detailed edges.

613

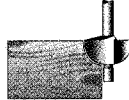

Piloted Cove Bit  
Routing of wood for cove cutting decorative edges.

614

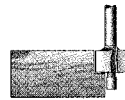

Piloted Rabbet Bit  
For rabbeting cuts.

615

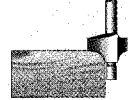

Piloted Corner Rounding Bit  
Rounding over edges and corners.

632

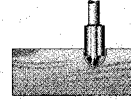

Veining Bit  
For veining or grooving.

640

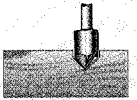

V-Groove Bit  
For sign word and lettering.

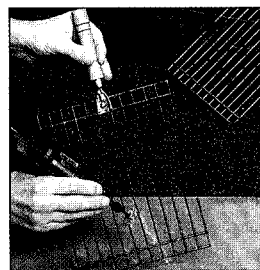

Aluminum Oxide  
Abrasive Wheels

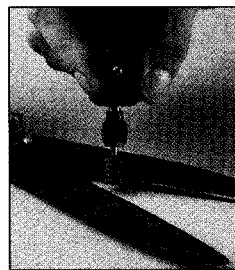
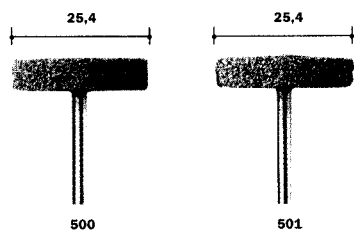

Aluminum Oxide  
Grinding Stones

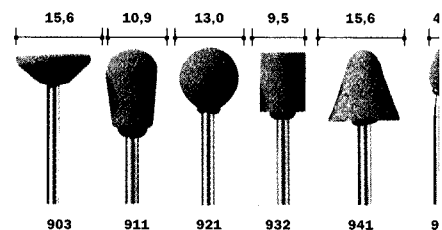

Model	QTY	Shank Ø mm	Use with	Ordernumber
-------	-----	------------	----------	-------------

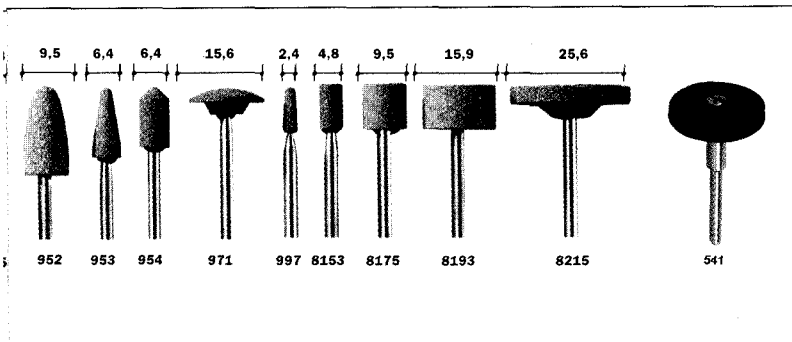
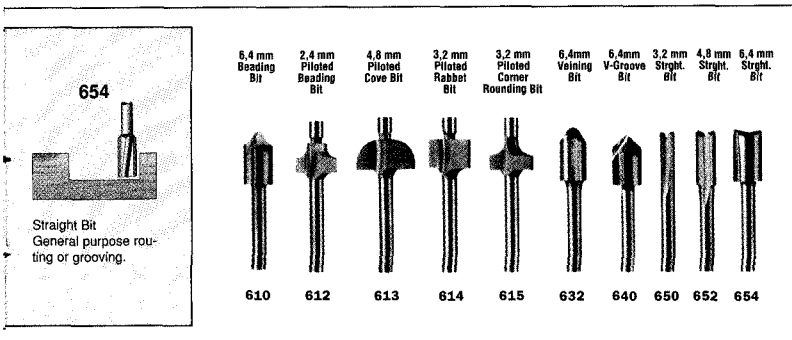
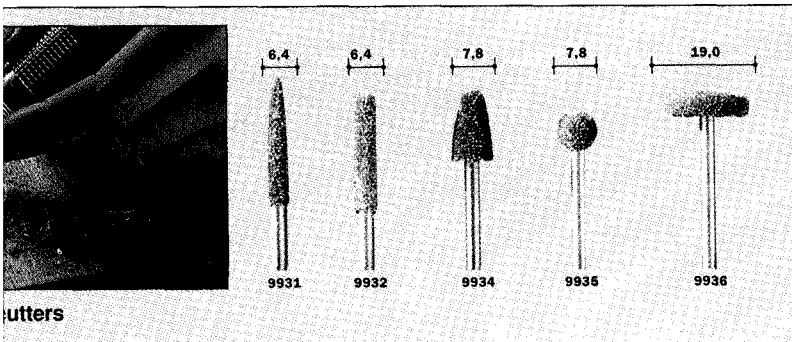
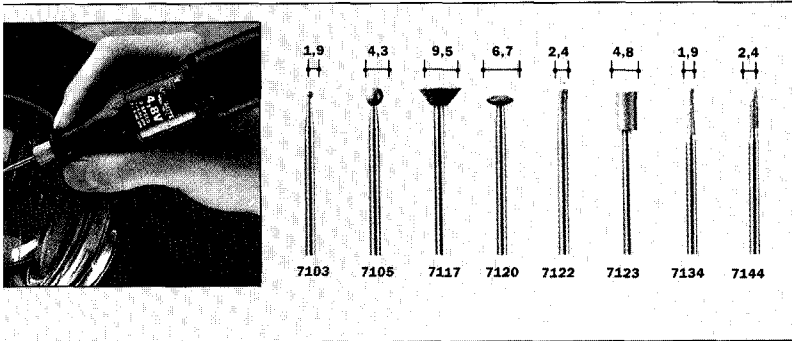
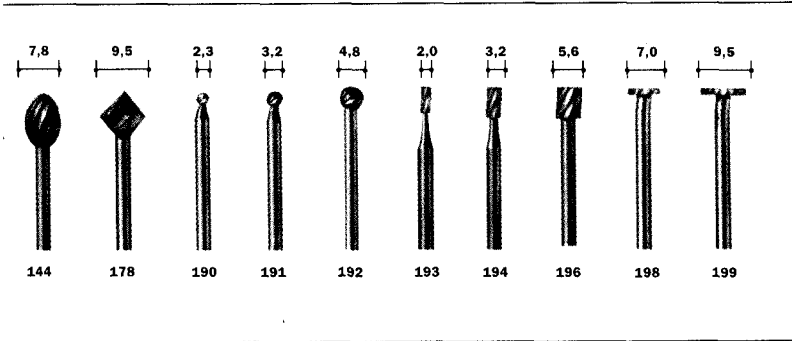

<b>High Speed Cutters</b>				
100	1	3,2		2615010032
114	1	3,2		2615011432
115	1	3,2		2615011532
116	1	3,2		2615011632
117	1	3,2		2615011732
118	1	3,2		2615011832
121	1	3,2		2615012132
124	1	3,2		2615012432
125	1	3,2		2615012532
131	1	3,2		2615013132
134	1	3,2		2615013432
144	1	3,2		2615014432
178	1	3,2		2615017832
190	1	3,2		2615019032
191	1	3,2		2615019132
192	1	3,2		2615019232
193	1	3,2		2615019332
194	1	3,2		2615019432
196	1	3,2		2615019632
198	1	3,2		2615019832
199	1	3,2		2615019932
<b>Tungsten carbide cutters</b>				
9901	1	3,2		2615990132
9902	1	3,2		2615990232
9903	1	3,2		2615990332
9904	1	3,2		2615990432
9905	1	3,2		2615990532
9906	1	3,2		2615990632
9909	1	3,2		2615990932
9910	1	3,2		2615991032
9911	1	3,2		2615991132
9912	1	3,2		2615991232
<b>Diamond wheel points</b>				
7103	1	2,4		2615710332
7105	1	2,4		2615710532
7117	1	2,4		2615711732
7120	1	2,4		2615712032
7122	1	2,4		2615712232
7123	1	2,4		2615712332
7134	1	2,4		2615713432
7144	1	2,4		2615714432
<b>Small engraving cutters</b>				
105	1	2,4		2615010532
106	1	2,4		2615010632
107	1	2,4		2615010732
108	1	2,4		2615010832
109	1	2,4		2615010932
110	1	2,4		2615011032
111	1	2,4		2615011132
112	1	2,4		2615011232
113	1	2,4		2615011332
<b>Structured tooth tungsten carbide cutters</b>				
9931	1	3,2		2615993132
9932	1	3,2		2615993232
9934	1	3,2		2615993432
9935	1	3,2		2615993532
9936	1	3,2		2615993632
<b>Router bits</b>				
610	1	3,2	230/231	2615061032
612	1	3,2	230/231	2615061232
613	1	3,2	230/231	2615061332
614	1	3,2	230/231	2615061432
615	1	3,2	230/231	2615061532
632	1	3,2	230/231	2615063232
640	1	3,2	230/231	2615064032
650	1	3,2	230/231	2615065032
652	1	3,2	230/231	2615065232
654	1	3,2	230/231	2615065432
<b>Aluminium Oxide Abrasive Wheels</b>				
500	1	3,2		2615050032
501	1	3,2		2615050132
<b>Aluminium Oxide Grinding stones</b>				
903	1	3,2		2615090332
911	1	3,2		2615091132
921	1	3,2		2615092132
932	1	3,2		2615093232
941	1	3,2		2615094132
945	1	3,2		2615094532
952	1	3,2		2615095232
953	1	3,2		2615095332
954	1	3,2		2615095432
971	1	3,2		2615097132
997	1	3,2		2615099732
8153	1	3,2		2615815332
8175	1	3,2		2615817532
8193	1	3,2		2615819332
8215	1	3,2		2615821532
541	1	3,2		2615054132
*Not included				



# Multi Accessories

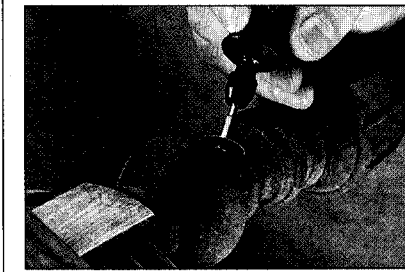

Sanding bands and discs

Ø 13,0 mm  
Coarse 60 Grit  
3,2 mm Shank



407

Ø 13,0 mm  
Coarse 60 Grit



408

Ø 13,0 mm  
Fine 120 Grit



432

Ø 6,4 mm  
Coarse 60 Grit  
3,2 mm Shank



430

Ø 6,4 mm  
Coarse 60 Grit



431

Ø 6,4 mm  
Fine 120 Grit



438

Ø 9,5 mm  
Coarse 60 Grit  
3,2 mm Shank



439

Ø 9,5 mm  
Coarse 60 Grit



440

Ø 9,5 mm  
Fine 120 Grit



444

Ø 19,0 mm  
Coarse 180 Grit



414



Silicone Carbide grinding stones

7,0 3,2 3,2 3,2 4,8 19,8 10,3 13,0

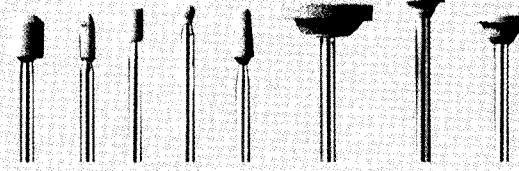

83142 83322 83702 84642 84922 85422 85602 85622

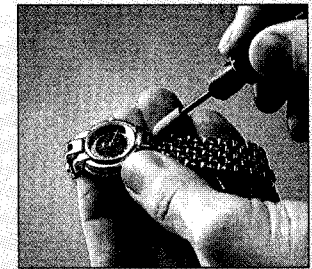

Rubber polishing points

6,4 6,4



461 462



Cleaning and polishing accessories

Polishing Compound

Ø 13,0 mm  
Felt



414  
Mandrel  
401



421

Ø 9,5 mm  
Felt



422  
Mandrel  
402

Ø 25,4 mm  
Cloth



423  
Mandrel  
402

Emery Impregnated  
22,2 mm Ø



425  
Mandrel  
402

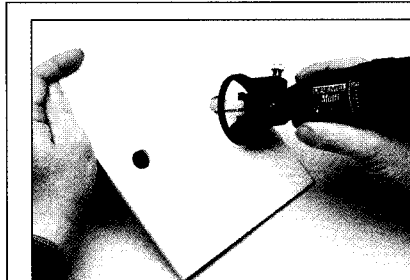

Tile cutter attachment accessories



560 Drywall  
Cutting Bit



561 Spiral  
Cutting Bit



562 Tile  
Cutting Bit

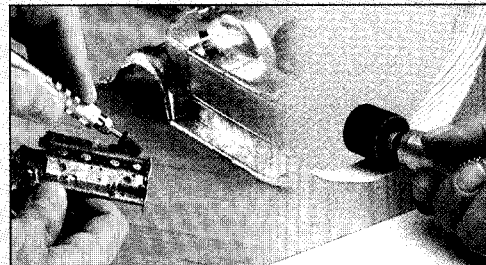

Multi Purpose Flex Shaft Tool accessories



507



508

Sanding bands. Structured tooth turn  
Ø 6,4 mm Shank for models no. 236.

Collets

Ø 3,2  
mm



585

Ø 2,3  
mm



587

Ø 6,3  
mm

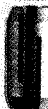

590

Collet Nut Kit no. 4485

Includes Collet Nut, 480, 481, 482, 483.

Ø 3,2  
mm



480

Ø 2,4  
mm



481

Ø 1,6  
mm

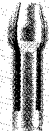

482

Ø 0,8  
mm



483



Collet Nut



Wire and bristle brushes

19,2 13,0 3,2

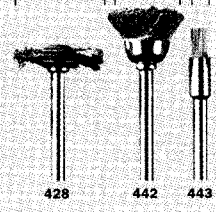

428

442

443

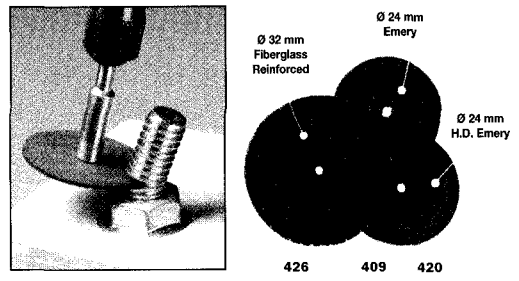
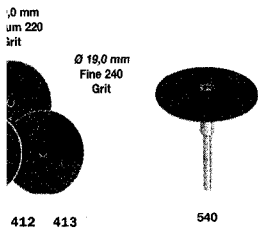

**Cut-off wheels**

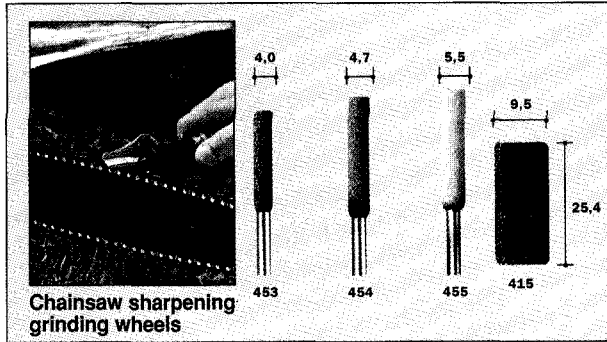
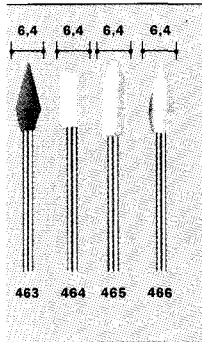

**Chainsaw sharpening grinding wheels**

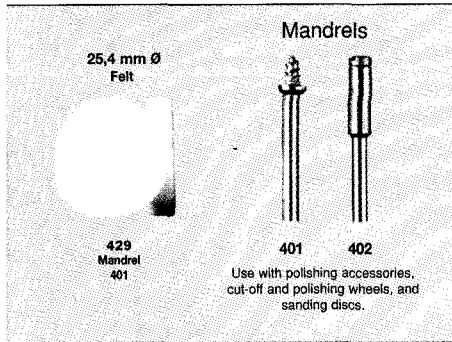

**Mandrels**

Use with polishing accessories, cut-off and polishing wheels, and sanding discs.

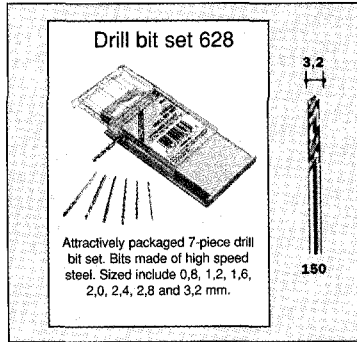

**Drill bit set 628**

Attractively packaged 7-piece drill bit set. Bits made of high speed steel. Sized include 0,8, 1,2, 1,6, 2,0, 2,4, 2,8 and 3,2 mm.

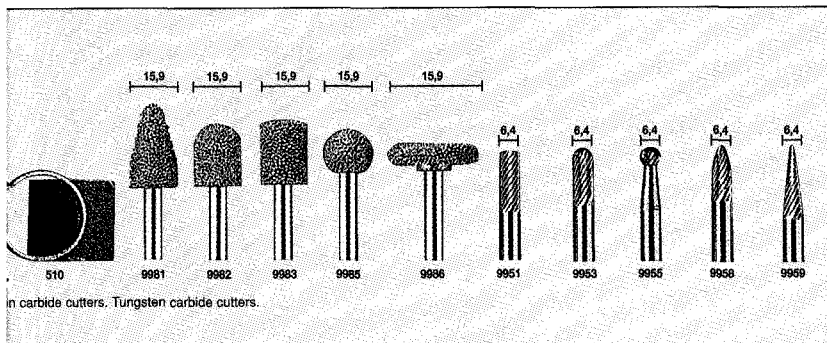

in carbide cutters. Tungsten carbide cutters.

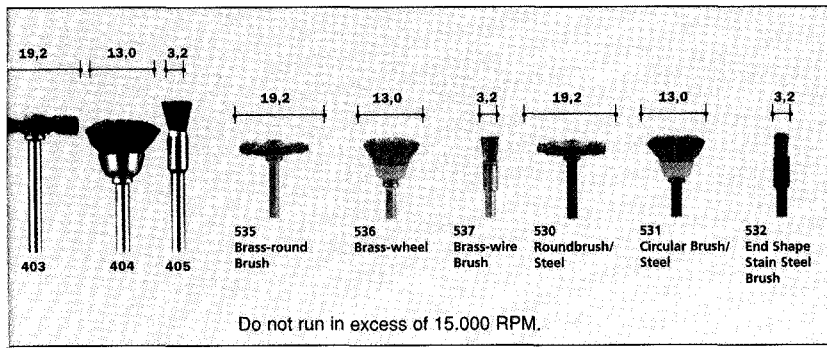

Do not run in excess of 15.000 RPM.

Model	QTY	Shank Ø mm	Use with	Ordernumber
<b>Sanding bands and discs</b>				
407	1	3,2		2615040732
408	6	3,2		2615040832
432	6	3,2		2615043232
430	1	3,2		2615043032
431	6	3,2		2615043132
438	6	3,2		2615043832
439	1	3,2		2615043932
440	6	3,2		2615044032
444	6	3,2		2615044432
411	36	3,2	402	2615041132
412	36	3,2	402	2615041232
413	36	3,2	402	2615041332
540	1	3,2		2615054032
<b>Cut-off wheels</b>				
426	5	3,2	402	2615042632
409	36	3,2	402	2615040932
420	20	3,2	402	2615042032
<b>Silicone Carbide grinding stones</b>				
83142	1	3,2		2615314232
83322	1	3,2		2615332232
83702	1	3,2		2615370232
84642	1	3,2		2615464232
84922	1	3,2		2615492232
85422	1	3,2		2615542232
85602	1	3,2		2615560232
85622	1	3,2		2615562232
<b>Rubber polishing points</b>				
461	1	3,2		2615046132
462	1	3,2		2615046232
463	1	3,2		2615046332
464	1	3,2		2615046432
465	1	3,2		2615046532
466	1	3,2		2615046632
<b>Chainsaw sharpening grinding wheels</b>				
453	2	3,2		2615045332
454	2	3,2		2615045432
455	2	3,2		2615045532
415	1	3,2		2615041532
<b>Mandrels</b>				
401	1	3,2		2615040132
402	1	3,2		2615040232
<b>Cleaning and polishing accessories</b>				
414	5	3,2	401	2615041432
421	1	3,2		2615042132
422	1	3,2	402	2615042232
423	1	3,2	402	2615042332
425	1	3,2	402	2615042532
429	1	3,2	401	2615042932
<b>Wire and bristle brushes</b>				
428	1	3,2		2615042832
442	1	3,2		2615044232
443	1	3,2		2615044332
403	1	3,2		2615040332
404	1	3,2		2615040432
405	1	3,2		2615040532
535	1	3,2		2615053532
536	1	3,2		2615053632
537	1	3,2		2615053732
530	1	3,2		2615053032
531	1	3,2		2615053132
532	1	3,2		2615053232
<b>Multi Purpose Flex Shaft Tool accessories</b>				
507	5	6,4		2615050732
508	5	6,4		2615050832
510	5	6,4		2615051032
9981	1	6,4		2615998132
9982	1	6,4		2615998232
9983	1	6,4		2615998332
9985	1	6,4		2615998532
9986	1	6,4		2615998632
9951	1	6,4		2615995132
9953	1	6,4		2615995332
9955	1	6,4		2615995532
9958	1	6,4		2615995832
9959	1	6,4		2615995932
<b>Drill bits</b>				
150	1	3,2		2615015032
628	7			2615062832
<b>Collets</b>				
480	1	3,2		2615048032
481	1	2,4		2615048132
482	1	1,6		2615048232
483	1	0,8		2615048332
4485	5			2615448532
585	1	3,2		2615058532
587	1	2,3		2615058732
590	1	6,3		2615059032
<b>Tile cutter attachment accessories</b>				
560	1	3,2		2615056032
561	1	3,2		2615056132
562	1	3,2		2615056232

\*Not included

# 1371 Moto-scroller

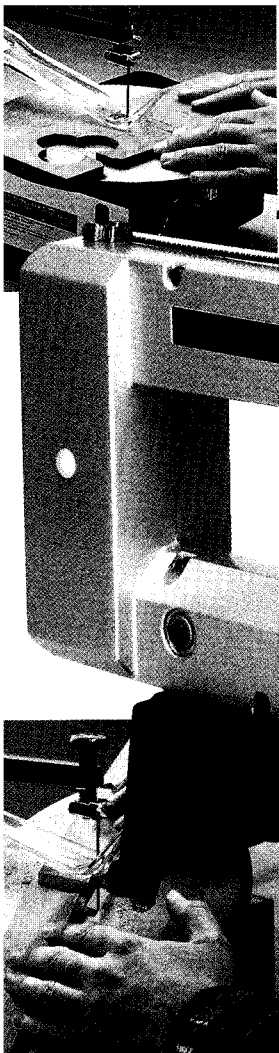

## Model 1371 Technical specifications:

Mains Supply .....	230 V
Input .....	110 Watt-1/7 hp
Capacity at 90° in wood .....	50 mm
Capacity at 90° in plastics .....	20 mm
Strokes p.m. ....	1350
Length of stroke .....	8 mm
Table size .....	Ø 254 mm
Throat depth .....	330 mm



## MOTO-SCROLLER MODEL 1371

High precision scroll-saw

- Very fine and smooth saw-cut
- Throat depth of 330 mm for large workpieces
- Large worktable-blade, adjustable up to 45° left
- Sawblade can be mounted in three positions for accurate scroll cuts or ripping long material
- Universal blade-retaining system
- Adjustable blade tension
- Vacuum cleaner connection
- Gauge for exact and easy mounting of blade adapters
- Vibration free and low noise level
- Extensive assortment of sawblades available
- Includes key, set of blade adapters and two sawblades

## Blades for use with Dremel Moto Scroller model 1371

### Plain-end Blades

Plain-end blades allow for extremely tight radius cutting and intricate cuts in wood, plastic, and fibrous materials. Use with no. 16436 Blade Adapter Set or the Quick Change Blade Adapter.

Catalog numbers	Width (mm)	Thick (mm)	Teeth per 2,5 cm
16440	0,56	0,25	28
16443	0,74	0,30	20
16446	0,96	0,40	12,5
16448	1,14	0,43	11,5
16453	1,57	0,50	9,5

### Metal Piercing Plain-end Blades

Metal piercing blades cut precious and non-ferrous metal. Must be used at slow speed. Perform best when lubricated\* with bees wax. Use with No. 16436 Blade Adapter Set.

Catalog numbers	Width (mm)	Thick (mm)	Teeth per 2,5 cm
16483	0,84	0,41	36

### Pin-end Blades

Pin-end blades are the easiest to take in and out of saw. For tight radius cutting in hard and soft wood.

Catalog numbers	Width (mm)	Thick (mm)	Teeth per 2,5 cm
16411	2,80	0,45	15
16412	2,80	0,45	10
16413	1,77	0,25	18,5

### Spiral Plain-end Blades

Spiral blades cut in all directions without turning the work piece. Use with No. 16436 Blade Adapter Set. For extremely tight cutting in wood, plastic and abrasive materials.

Catalog numbers	Width (mm)	Thick (mm)	Teeth per 2,5 cm
16461	46	0,71 - 0,76	46,0
16463	41	0,86 - 0,91	41,0

# 1731 Moto-sander

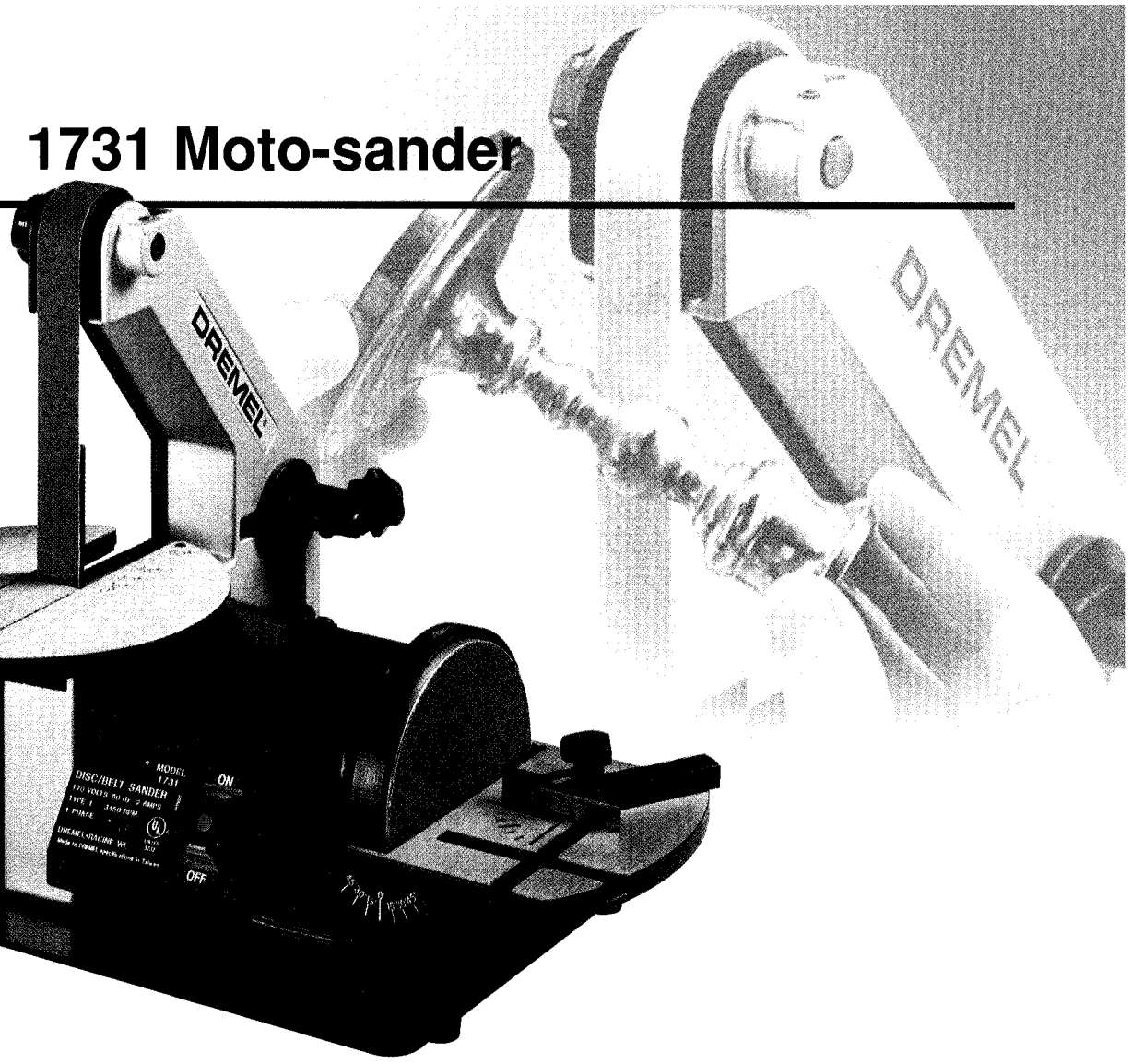
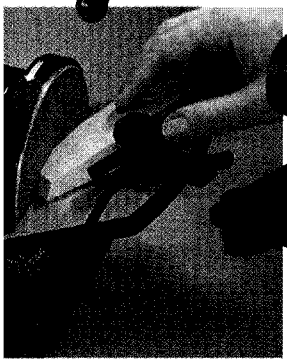

## MOTO-SANDER MODEL 1731

High precision disc/belt sander combination for precise modeling, sanding, grinding, polishing, cleaning and sharpening.

- Beltsander:
  - High belt speed
  - 60° adjustable belt table with slide plate to support smaller workpieces
  - Belt tracking and tension control mechanism
  - Easy belt changing
  - Removable belt support bracket
- Disc sander:
  - High speed
  - 45° up and down adjustable disc table with bevel guide
- Dust wand
- Various sanding belts and sanding discs available
- Includes key, sanding belt and sanding disc

## Accessoires for Model 1731 Moto-Sander

Sanding discs 125 mm dia

Model	Grit
8051	80
8052	120

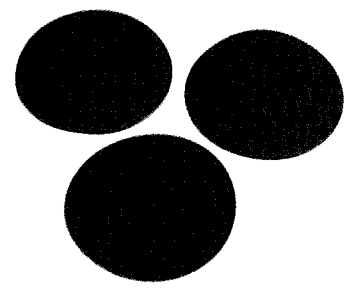

Belts 25,4 x 762 mm

Model	Grit
8041	80
8042	120
8044	240

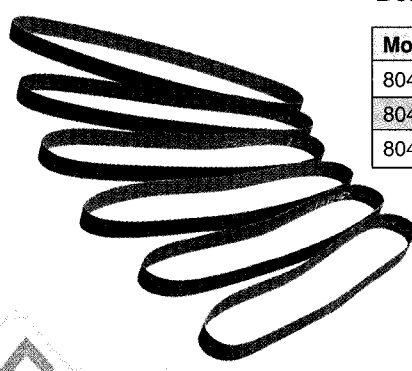

## Model 1731 Technical specifications:

Input.....	180 Watt-1/4hp
Belt speed.....	960 m/min
Belt size.....	25,4 x 762 mm
Table size.....	Ø 178 mm dia
Disc speed.....	3450 RPM
Disc size.....	Ø 127 mm dia
Table size.....	108 x 152 mm

**TOOLS**

Model	Partnumber	EAN 8710364
6000	F01360003R	011582
395	F0130395FR	007004
3950	F0133950FR	007011
7701	F013770183	010493
752	F013075232	006519
7360	F013736084	011391
1371	F013137183	005017
1731	F013173183	005024

**DREMEL ATTACHMENTS**

Model	Ordernumber	EAN 8710364
212	F013021232	008964
225	F013022532	008957
230	F013023032	008940
231	F013023132	008933
565	2615056532	010622
566	2615056632	010639
1453	2615145332	009398
2214	2615221432	000944
2217	2615221732	000975
2222	F013222232	002146

**DREMEL ACCESSORIES**

Model	Partnumber	EAN 8710364
<b>High Speed Cutters</b>		
100	2615010032	007851
114	2615011432	007868
115	2615011532	007332
116	2615011632	008803
117	2615011732	007875
118	2615011832	007349
121	2615012132	007882
124	2615012432	007899
125	2615012532	007356
131	2615013132	007905
134	2615013432	007912
144	2615014432	007936
178	2615017832	007943
190	2615019032	007967
191	2615019132	007974
192	2615019232	007363
193	2615019332	007370
194	2615019432	007387
196	2615019632	007394
198	2615019832	007998
199	2615019932	007400
<b>Tungsten carbide cutters</b>		
9901	2615990132	008605
9902	2615990232	008612
9903	2615990332	008629
9904	2615990432	008636
9905	2615990532	008643
9906	2615990632	008650
9909	2615990932	008667
9910	2615991032	008674
9911	2615991132	008681
9912	2615991232	008698
<b>Multi Purpose Flex Shaft Tool accessories</b>		
9951	2615995132	008759
9953	2615995332	008766
9955	2615995532	008773
9958	2615995832	008780
9959	2615995932	008797
9981	2615998132	008704
9982	2615998232	008711
9983	2615998332	008728
9985	2615998532	008735
9986	2615998632	008742

**ACCESSORIES**

Model	Partnumber	EAN 8710364
507	2615050732	009428
508	2615050832	009411
510	2615051032	009404
<b>Router bits</b>		
610	2615061032	008247
612	2615061232	008254
613	2615061332	008261
614	2615061432	008278
615	2615061532	008285
632	2615063232	008292
640	2615064032	008308
650	2615065032	007417
652	2615065232	008315
654	2615065432	008322
<b>Drill bits</b>		
150	2615015032	008001
628	2615062832	009381
<b>Structured tooth tungsten carbide cutters</b>		
9931	2615993132	008544
9932	2615993232	008551
9933	2615993332	008568
9934	2615993432	008575
9935	2615993532	008582
9936	2615993632	08599
<b>Diamond wheel points</b>		
7103	2615710332	008469
7105	2615710532	008476
7117	2615711732	008483
7120	2615712032	008490
7122	2615712232	008506
7123	2615712332	008513
7134	2615713432	008520
7144	2615714432	008537
<b>Small engraving cutters</b>		
105	2615010532	007288
106	2615010632	007295
107	2615010732	007301
108	2615010832	007318
109	2615010932	007813
110	2615011032	007820
111	2615011132	007837
112	2615011232	007844
113	2615011332	007325
<b>Aluminum Oxide Abrasive Wheels</b>		
500	2615050032	008025
501	2615050132	008032
<b>Aluminum Oxide Grinding Stones</b>		
541	2615054132	010523
903	2615090332	008049
911	2615091132	008056
921	2615092132	008063
932	2615093232	007455
941	2615094132	008070
945	2615094532	008087
952	2615095232	007462
953	2615095332	007479
954	2615095432	008094
971	2615097132	008100
997	2615099732	007486
<b>Sanding bands and discs</b>		
411	2615041132	008421
412	2615041232	008438
413	2615041332	008445
407	2615040732	007226
408	2615040832	007233
430	2615043032	007240
431	2615043132	007257
432	2615043232	007264
438	2615043832	007271
439	2615043932	008391
440	2615044032	008407
444	2615044432	008414

