



Type 702042



Type 702044



Type 702041



Type 702043



Type 702040

**JUMO** iTRON

Compact micro-processor controllers

**B 70.2040**  
**Operating Manual**

12.99/00357918



Please read this Manual carefully before starting up the instrument. Keep this manual in a place which is at all times accessible to all users. Please assist us to improve this manual where necessary. Your suggestions will be most welcome.

Phone      in Germany (0661) 6003-727  
              from abroad (+49) 661 6003-0  
Fax         in Germany (0661) 6003-508  
              from abroad (+49) 661 6003-607



All necessary settings are described in this Operating Manual. If any difficulties should still arise during start-up, you are asked not to carry out any unauthorised manipulations on the unit. You could endanger your rights under the warranty. Please contact the nearest office or the main factory.



When returning chassis, assemblies or components, the rules of EN 100 015 “Protection of electrostatically endangered components” have to be observed. Use only the appropriate **ESD** packaging material for transport.

Please note that we can not be held liable for damages caused by ESD (electrostatic discharge).

# Contents

<b>1</b>	<b>Identifying the instrument version</b>	<b>4</b>
<b>2</b>	<b>Installation</b>	<b>6</b>
<b>3</b>	<b>Electrical connection</b>	<b>7</b>
<b>4</b>	<b>Operation</b>	<b>11</b>
4.1	Displays and keys	11
4.2	Principle of operation	12
<b>5</b>	<b>Functions</b>	<b>14</b>
5.1	Process value input	15
5.2	Logic input	16
5.3	Controller	17
5.4	Limit comparators (alarm contact)	19
5.5	Ramp function	20
5.6	Self-optimisation	21
5.7	Level inhibit via code	22
<b>6</b>	<b>Configuration and parameter tables</b>	<b>23</b>
<b>7</b>	<b>Alarm messages</b>	<b>27</b>
<b>8</b>	<b>Technical data</b>	<b>28</b>

# 1 Identifying the instrument version

7020 (1) .. / (2) .. - (3) ... - (4) ... - (5) .. / (6) ..

<b>(1) Basic type</b> (bezel in mm)	<b>40</b> = 48 x 24, <b>41</b> = 48 x 48, <b>42</b> = 48 x 96 (portrait), <b>43</b> = 96 x 48 (landscape), <b>44</b> = 96 x 96		
<b>(2) Basic type extensions</b>	<b>88</b> = controller type configurable <sup>1</sup> <b>99</b> = controller type configurable to customer specifications <sup>2</sup>		
<b>(3) Inputs</b>	<b>888</b> = inputs configurable <sup>1</sup> <b>999</b> = inputs configured to customer specifications <sup>2</sup>		
<b>(4) Outputs (standard)</b>		Type 702040/41	Type 702042/43/44
	output 1	relay (n.o. make)	relay (n.o. make)
	output 2	logic 0/5V, optionally configurable as logic input	relay (n.o. make) and parallel logic 0/5V
<b>(4) Output 2 (option)</b>	<b>113</b> = output 2	logic 0/12V, optionally configurable as logic input	(not possible)
	<b>000</b> = option not available		
<b>(5) Supply</b>	<b>16</b> = 10 – 18V DC <b>22</b> = 20 – 53V AC/DC 48 – 53 Hz <b>23</b> = 110 – 240V -15/+10% AC 48 – 63Hz		
<b>(6) Extra Code</b>	<b>061</b> = UL approval (Underwriters Laboratories)		

1. Single-setpoint controller with limit comparator, see factory settings under configuration and parameter levels
2. See customer's ordering text or settings under configuration and parameter levels

<b>Delivery package</b>	ex-factory for	Type 702040/41	Type 702042/43/44
		1 mounting frame	2 fixing elements
		1 seal, 1 Operating Manual 70.2040	

## 2 Installation

°C 55

≤90

Installation 702042 as 702044

1. Push on seal  
2. Insert instrument  
3. Push on fixing elements  
4. Tighten screws

Type (bezel)	Panel cut-out (WxH) in mm	Edge-to-edge mounting (minimum spacings of the panel cut-outs)	
		horizontal	vertical
702040 (48mm x 24mm)	$45^{+0.6} \times 22.2^{+0.3}$	> 8mm	> 8mm
702041 (48mm x 48mm)	$45^{+0.6} \times 45^{+0.6}$	> 8mm	> 8mm
702042 (48mm x 96mm)	$45^{+0.6} \times 92^{+0.8}$	> 10mm	> 10mm
702043 (96mm x 48mm)	$92^{+0.8} \times 45^{+0.6}$	> 10mm	> 10mm
702044 (96mm x 96mm)	$92^{+0.8} \times 92^{+0.8}$	> 10mm	> 10mm

## 3 Electrical connection

### Installation notes

- The choice of cable, the installation and the electrical connection must conform to the requirements of VDE 0100 “Regulations on the Installation of Power Circuits with nominal voltages below 1000V”, or the appropriate local regulations.
- The electrical connection must only be carried out by properly qualified personnel.
- If contact with live parts is possible when working on the instrument, it has to be isolated on both poles from the supply.
- A current limiting resistor interrupts the supply circuit in the event of a short-circuit. The external fuse of the supply should not be rated above 1A (slow). The load circuit must be fused for the maximum relay current in order to prevent welding of the output relay contacts in the event of an external short-circuit.
- Electromagnetic compatibility conforms to the standards and regulations listed under Technical Data.
- Run input, output and supply lines separately and not parallel to each other.

- Sensor lines should be arranged as twisted and screened cables. Do not run them close to current-carrying components or cables.
- Do not connect any additional loads to the supply terminal of the instrument.
- The instrument is not suitable for installation in hazardous areas.
- Apart from faulty installation, there is a possibility of interference or damage to controlled processes due to incorrect settings on the controller (setpoint, data of parameter and configuration levels, internal adjustments).  
Safety devices independent of the controller, such as overpressure valves or temperature limiters/monitors, should always be provided and should be capable of adjustment only by specialist personnel.  
Please refer to the appropriate safety regulations in this connection. Since auto-tuning (self-optimisation) can not be expected to handle all possible control loops, there is a theoretical possibility of unstable parameter settings. The resulting process value should therefore be monitored for its stability.

# Type 702040/41

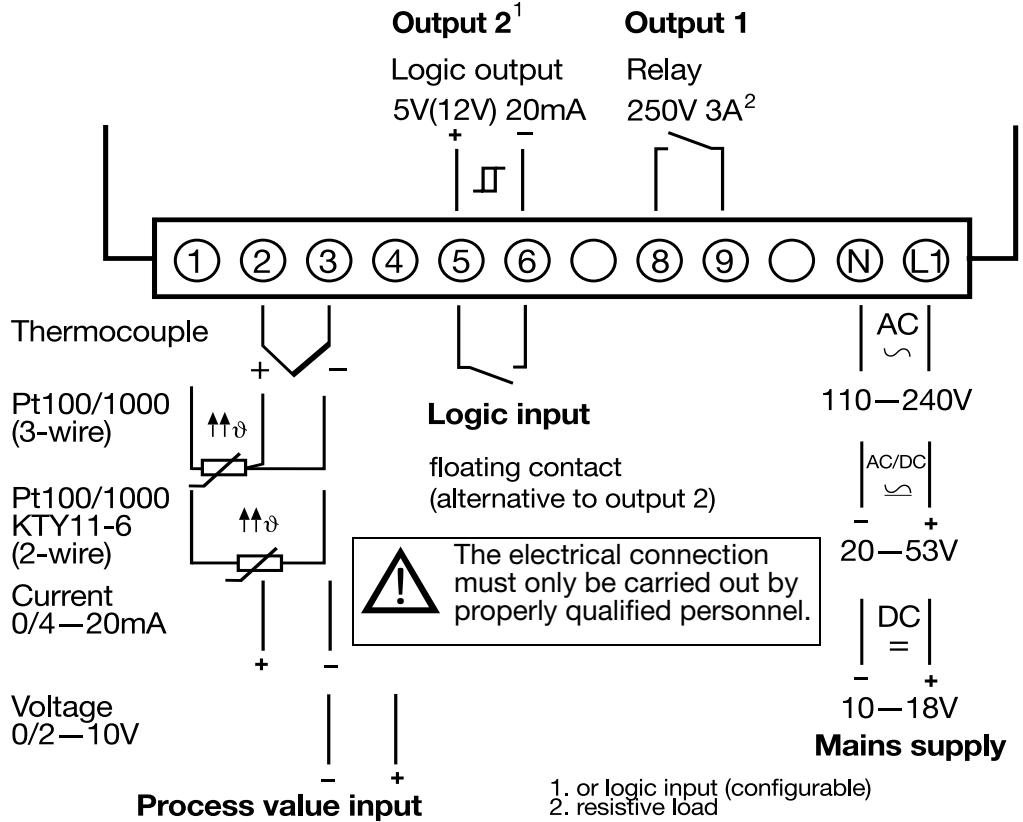

# Type 702042/43/44

**Output 2**

Logic output  
5V 20mA



**Output 1**

Relay  
250V 3A<sup>2</sup>



**Output 2**

Relay  
250V 3A<sup>2</sup>

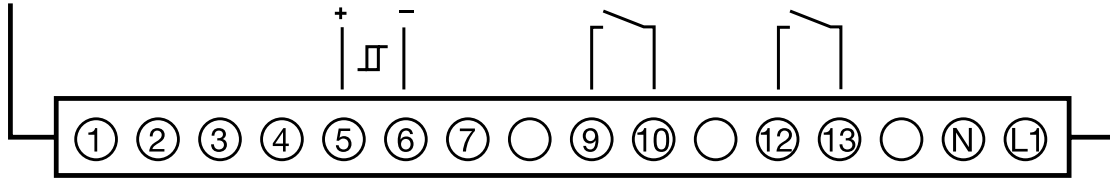

Thermocouple



Pt100/1000  
(3-wire)

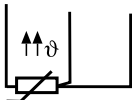

Pt100/1000  
KTY11-6  
(2-wire)

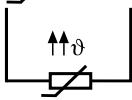

Current  
0/4—20mA



Voltage  
0/2—10V



**Process value input**

**Logic input**

floating contact



The electrical connection must only be carried out by properly qualified personnel.



110—240V



20—53V



10—18V

**Mains supply**

2. resistive load

## 4 Operation

### 4.1 Displays and keys

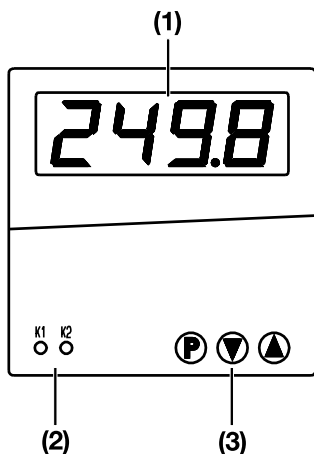

Example: Type 702041

#### (1) Display

7-segment display	four digits, green
Character height	Type 702040/41/42: 10mm Type 702043/44: 20mm
Display range	-1999 to +9999 digit
Decimal places	none, one, two
Unit	°C/ °F

#### (2) Status indication

LED	two LEDs for the outputs 1 and 2, yellow
-----	--

#### (3) Keys

	select next parameter select parameter and configuration level (at least 2 sec)
	increment parameter value <sup>1</sup>
	decrement parameter value <sup>1</sup>
+	instant return to basic status

1. Dynamic value setting; after 2 sec the value is accepted automatically (also configuration codes)

## 4.2 Principle of operation

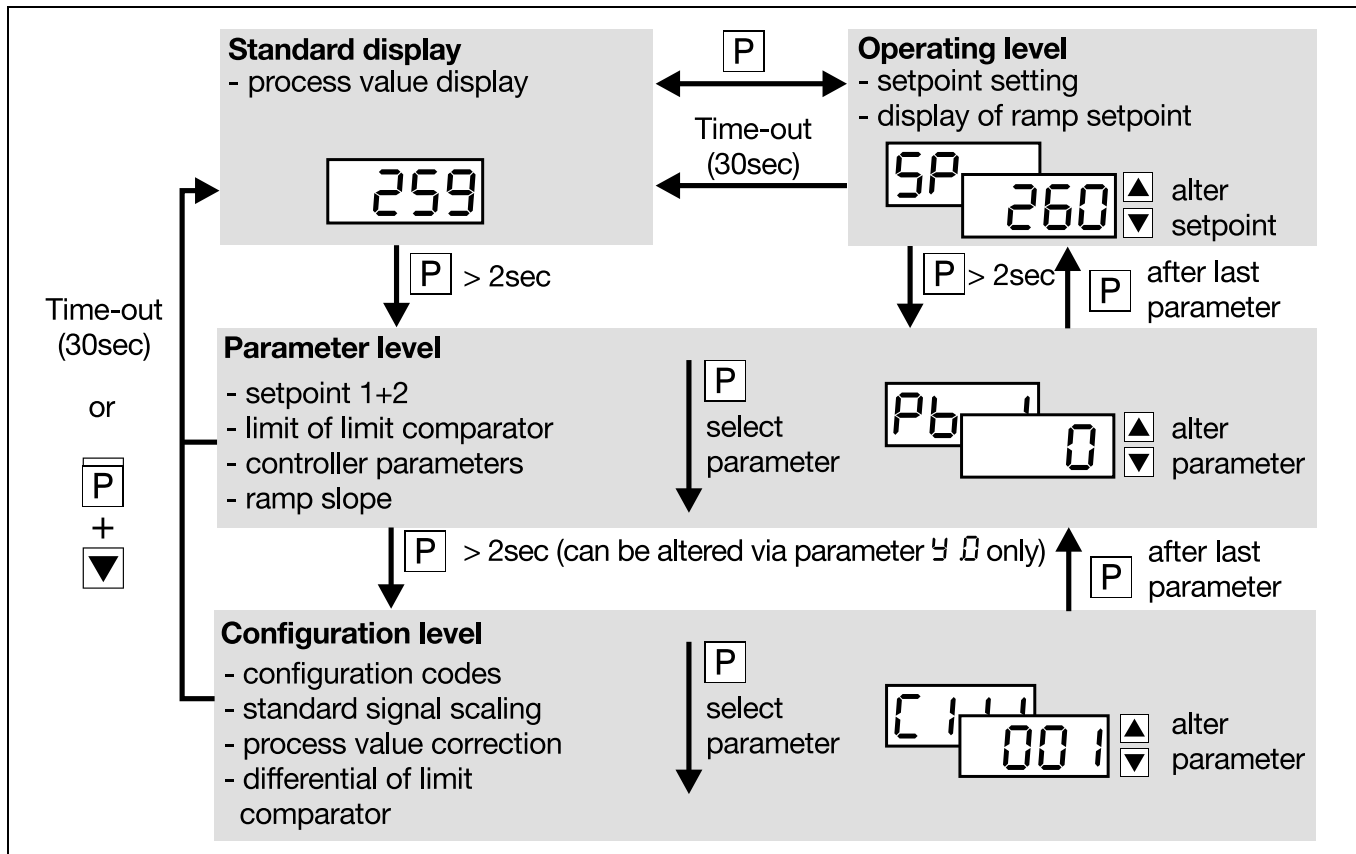

## Standard display

The display shows the process value.



## Operating level

The setpoint  $SP$  is input here. On active setpoint switching via the logic input,  $SP 1$  or  $SP 2$  appears on the display. When the ramp function is active, the ramp setpoint  $SP_r$  is displayed.

## Parameter level

The setpoints, the limit value of the limit comparator, the controller parameters and the ramp slope are programmed here.



The parameter symbol and the parameter value are displayed alternately.

The parameters are changed dynamically by using the keys  and . The setting is accepted automatically after approx. 2 sec.

## Configuration level

The basic functions of the controller are set here.

**In order to make the settings, it is necessary to change to the configuration level via the parameter  $9.0$  (parameter level).**

The configuration code (e.g.  $1111$ ) or the parameter symbol (e.g.  $Pb . 1$ ) and the code/parameter value are shown alternately on the display. The parameters are changed dynamically by using the keys  and . The setting is accepted automatically after approx. 2 sec.

## Time-out

If no operation occurs, the controller returns automatically to standard display after approx. 30 sec.

# 5 Functions

We recommend the following procedure:

- \* Familiarise yourself with the functions of the controller
- \* Enter the configuration codes and the parameter values in the tables provided for this purpose in Chapter 6. Write down the appropriate values (✎) or mark selections with a cross (X✎). The parameters and configuration codes are listed in the order of their appearance. Parameters which are not relevant are blanked out (see table below).
- \* Enter the configuration codes and the parameters in the unit.



## Blanking out irrelevant parameters

Configuration	Blanking out the parameters for	Parameter
Single-setpoint controller	Double-setpoint controller	Pb. 2, CY 2, db, HYS. 2
Double-setpoint controller	Limit comparator, logic input for Type 702040/41	C 114, HYS t, AL C 117
Limit comparator without function	Limit comparator	HYS t, AL
Limit comparator with function	Logic input for Type 702040/41	C 117
Resistance thermometer, thermocouple	Standard signal scaling	SCL, SCH
Ramp function without function	Ramp function	rASd
No setpoint switching	Setpoints at parameter level	SP 1, SP 2

## 5.1 Process value input

Symbol	Notes									
[ 1 1 1	<b>Transducer/sensor (process value input)</b> ⇒ page 23									
[ 1 1 2	<b>Unit of the process value (°C/°F) /decimal places of display</b> ⇒ page 23									
5CL	<b>Start /end value of the value range</b> for standard signals ⇒ page 25 Example: 0–20 mA→20– 200°C: 5CL = 20 / 5CH = 200									
5CH										
OFFS	<p><b>Process value correction</b> ⇒ page 25</p> <p>Using the process value correction, a measured value can be corrected by a programmable amount up or down (offset). Lead compensation can be implemented in software for 2-wire circuit through process value correction.</p> <p>Examples:</p> <table border="1"> <thead> <tr> <th>Measured value</th> <th>Offset</th> <th>Displayed value</th> </tr> </thead> <tbody> <tr> <td>294.7</td> <td>+ 0.3</td> <td>295.0</td> </tr> <tr> <td>295.3</td> <td>- 0.3</td> <td>295.0</td> </tr> </tbody> </table>	Measured value	Offset	Displayed value	294.7	+ 0.3	295.0	295.3	- 0.3	295.0
Measured value	Offset	Displayed value								
294.7	+ 0.3	295.0								
295.3	- 0.3	295.0								
dF	<p><b>Filter time constant</b> (damping) to adapt the digital input filter (0sec = filter off) ⇒ page 26</p> <p>if dF high:</p> <ul style="list-style-type: none"> <li>- high damping of interference signals</li> <li>- slow reaction of the process value display to changes in process value</li> <li>- low cut-off frequency (2nd order low-pass filter)</li> </ul>									

## 5.2 Logic input

		
<b>Key inhibit</b>	Operation is possible by keys	<b>No</b> operation by keys
<b>Level inhibit</b>	Access to the levels is possible. Starting self-optimisation is possible.	Access to the levels is <b>not</b> possible. Starting self-optimisation is <b>not</b> possible.
<b>Ramp stop</b>	Ramp running	Ramp stopped
<b>Setpoint switching</b>	Setpoint $SP\ 1$ is active The appropriate symbols $SP\ 1$ and $SP\ 2$ are displayed at the operating level.	Setpoint $SP\ 2$ is active

Symbol	Notes
[ 117	<b>Function of the logic input</b> ⇒ page 25 On Type 702040/41, the logic output function becomes automatically inactive (double assignment).



## 5.3 Controller

### Controller structure

The controller structure is defined via the parameters  $P_b$ ,  $d_t$  and  $r_t$ .

Example: Setting for PI controller  $\rightarrow P_b . 1 = 120$ ,  $d_t = 0 \text{ sec}$ ,  $r_t = 350 \text{ sec}$

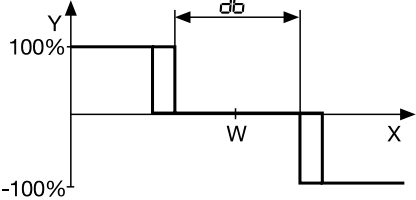
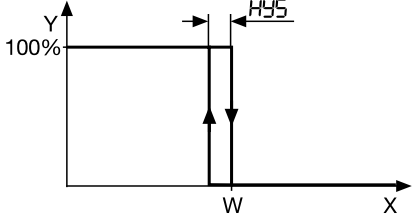
Symbol	Notes
$[ 1 ] 3$	<b>Controller type and assignment of the controller outputs to the physical outputs 1+2</b> $\Rightarrow$ page 24
$[ 1 ] 6$	<b>Outputs in the event of an error</b> $\Rightarrow$ page 25 The switching states of the outputs are defined here in the event of over/underrange, probe break/short-circuit or display overflow. $\Rightarrow$ Chapter 7
$P_b . 1$	<b>Proportional band 1</b> (controller output 1) $\Rightarrow$ page 26
$P_b . 2$	<b>Proportional band 2</b> (controller output 2) Influences the P action of the controller. If $P_b = 0$ the controller structure is ineffective.
$d_t$	<b>Derivative time</b> $\Rightarrow$ page 26 Influences the D action of the controller. If $d_t = 0$ the controller has no D action.
$r_t$	<b>Reset time</b> $\Rightarrow$ page 26 Influences the I action of the controller. If $r_t = 0$ the controller has no I action.
$[ 4 ] 1$	<b>Switching cycle duration 1</b> (controller output 1) $\Rightarrow$ page 26
$[ 4 ] 2$	<b>Switching cycle duration 2</b> (controller output 2) The cycle time should be selected so that the energy supply to the process is virtually continuous, while not subjecting the switching elements to excessive wear.

Symbol	Notes
$db$	<p><b>Contact spacing</b> <math>\Rightarrow</math> page 26 for double-setpoint controllers</p> 
$HYS.1$	<p><b>Differential (hysteresis) 1</b> (controller output 1) <math>\Rightarrow</math> page 26</p> <p><b>Differential (hysteresis) 2</b> (controller output 2) for controllers with <math>P_b.1=0</math> or <math>P_b.2=0</math></p> 
$HYS.2$	
$Y.0$	<p><b>Working point (basic load)</b> <math>\Rightarrow</math> page 26 output at process value = setpoint</p>
$Y.1$	<p><b>Output limitation</b> <math>\Rightarrow</math> page 26 <math>Y.1</math> - maximum output</p>
$Y.2$	<p><math>Y.2</math> - minimum output</p> <p> For controllers without controller structure (<math>P_b.1=0</math> or <math>P_b.2=0</math>) it is necessary that <math>Y.1 = 100\%</math> and <math>Y.2 = -100\%</math></p>

## 5.4 Limit comparators (alarm contact)

lk1

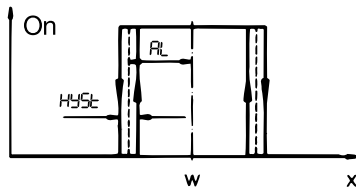

lk2

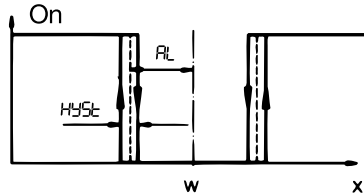

lk3

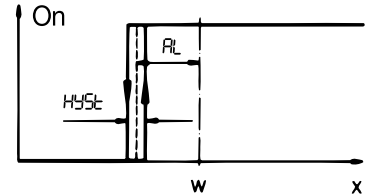

lk4

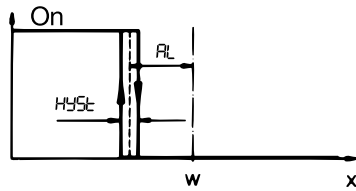

lk5

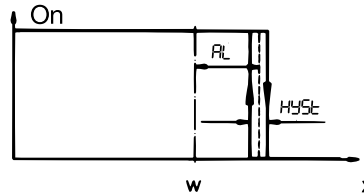

lk6

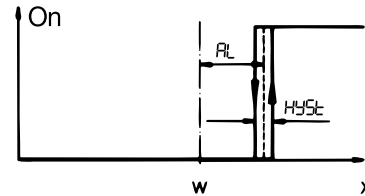

lk7

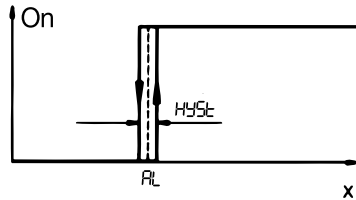

lk8

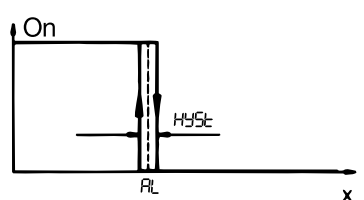

lk1 – lk6: Monitoring referred to the setpoint.

lk7 / lk8: Monitoring referred to a fixed value  $RL$ .

w = setpoint, x = process value

Symbol	Notes
$[14]$	Limit comparator function (lk1 – lk8) ⇒ page 24
$HYSL$	Switching differential (hysteresis) of the limit comparator ⇒ page 25
$RL$	Limit value of the limit comparator ⇒ page 26

## 5.5 Ramp function

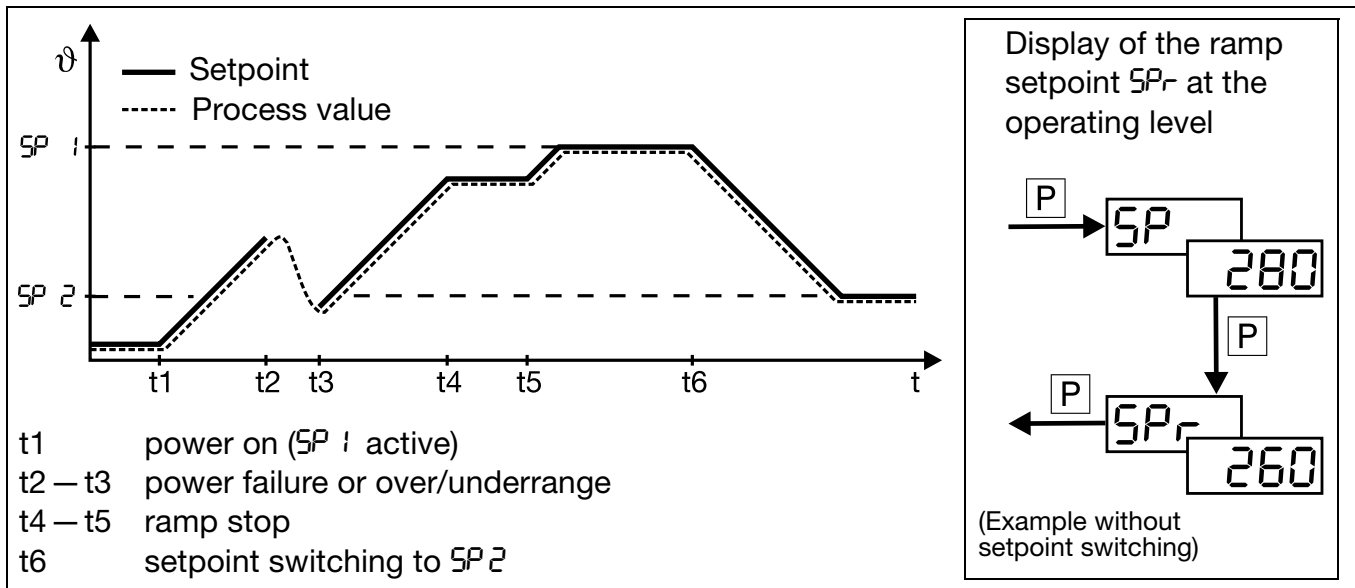

Symbol	Notes
[ 115	Ramp function (on/off, time unit) ⇒ page 24
[ 117	Ramp stop via logic input (floating contact) ⇒ page 25
rASd	Ramp slope in °C/h or °C/min ⇒ page 26

## 5.6 Self-optimisation

Self-optimisation determines the optimum controller parameters for PID or PI controllers.

The following controller parameters are defined:  $rT$ ,  $dT$ ,  $Pb.1$ ,  $Pb.2$ ,  $CY1$ ,  $CY2$ ,  $dF$

The controller selects procedure **a** or **b**, depending on the size of the control deviation:

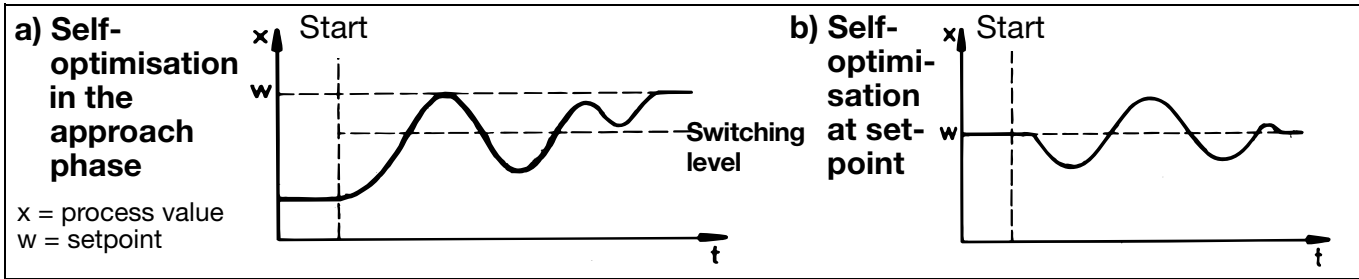

### Starting self-optimisation



Starting self-optimisation is not possible with active level inhibit and ramp function.

Self-optimisation is automatically terminated or can be cancelled.

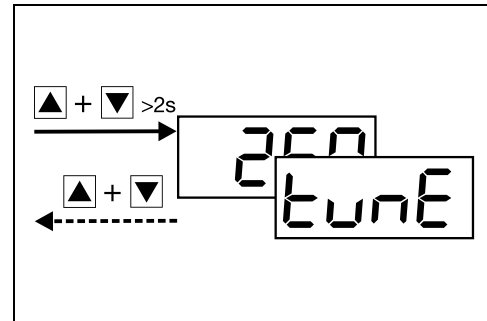



## 5.7 Level inhibit via code

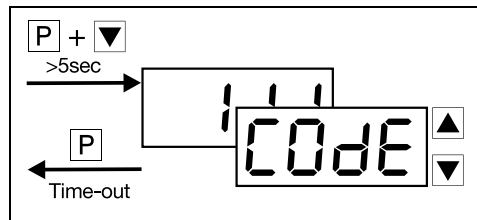

As an alternative to the logic input, the level inhibit can be set via a code (logic input has priority).



Code	Operating level	Parameter level	Configuration level
000	enabled	enabled	enabled
001	enabled	enabled	inhibited
011	enabled	inhibited	inhibited
111	inhibited	inhibited	inhibited

## 6 Configuration and parameter tables

[ 111	Transducer	X 	[ 112	Decimal places/unit	X 
<b>P</b> >2sec	001 Pt 100 (3-wire)		<b>P</b>	0 9999/°C	
	006 Pt 1000 (3-wire)			1 999.9/°C	
	601 KTY11-6 (2-wire)			2 99.99/°C	
	003 Pt 100 (2-wire)			3 9999/°F	
	005 Pt 1000 (2-wire)			4 999.9/°F	
	039 Cu-Con T			5 99.99/°F	
	040 Fe-Con J				
	041 Cu-Con U				
	042 Fe-Con L				
	043 NiCr-Ni K				
	044 Pt10Rh-Pt S				
	045 Pt13Rh-Pt R				
	046 Pt30Rh-Pt B				
	048 NiCrSi-NiSi N				
	052 Standard signal 0 – 20mA				
	053 Standard signal 4 – 20mA				
	063 Standard signal 0 – 10V				
	071 Standard signal 2 – 10V				

 → [ 112  
 → [ 113

1. SP I, AL or Pb. I is shown here, depending on the configuration.



Mark your selection with a cross.

<b>112</b>	<b>113</b>	<b>Controller type</b>	<b>Output 1</b>	<b>Output 2</b>	<b>X</b>
	10	single setpoint (reversed)	controller	limit comparator	
	11	single setpoint (direct)	controller	limit comparator	
	30	double setpoint	controller reversed	controller direct	
	20	single setpoint (reversed)	limit comparator	controller	
	21	single setpoint (direct)	limit comparator	controller	
	33	double setpoint	controller direct	controller reversed	

P

<b>114</b>	<b>Limit comparator (LK)</b>	<b>X</b>
0	no function	
1	lk 1	
2	lk 2	
3	lk 3	
4	lk 4	
5	lk 5	
6	lk 6	
7	lk 7	
8	lk 8	



P

<b>115</b>	<b>Ramp function</b>	<b>X</b>
0	ramp function off	
1	ramp function (°C/min)	
2	ramp function (°C/h)	

P

116

reversed = heating (output is active when process value is below setpoint)  
 direct = cooling (output is active when process value is above setpoint)

C115	→	C116	<b>Outputs on fault</b>	X 	→	C117	<b>Logic input</b>	X 
0		0	0 % output <sup>1</sup> /LK off		P	0	no function	
1		1	100 % output <sup>2</sup> /LK off			1	Key inhibit	
2		2	-100 % output <sup>1</sup> /LK off			2	Level inhibit	
3		3	0 % output <sup>2</sup> /LK on			3	Ramp stop	
4		4	100 % output <sup>1</sup> /LK on			4	Setpoint switching	

1. Minimum output 5.2 active
2. Maximum output 5.1 active

Parameter	Explanation	Value range	factory-set	Your setting 
SCL	Start value of standard signal	-1999 to +9999 digit	0	
SCH	End value of standard signal	-1999 to +9999 digit	100	
SPL	Lower setpoint limit	-1999 to +9999 digit	-200	
SPH	Upper setpoint limit	-1999 to +9999 digit	850	
OFFS	Process value correction	-1999 — 9999 digit <sup>3</sup>	0	
HYST	Switching differential of limit comparator	0 — 9999 digit <sup>3</sup>	1	

3. On the display with one or two decimal places, the value range and the factory setting change accordingly.  
Example: 1 decimal place → value range: -199.9 to +999.9

HYST →

Parameter	Explanation	Value range	factory-set	Your setting 
SP 1	Setpoint 1	SPL – SPH	0	
SP 2	Setpoint 2	SPL – SPH	0	
AL	Limit value of limit comparator	-1999 to +9999 digit	0	
Pb .1	Proportional band 1	0 – 9999 digit <sup>1</sup>	0	
Pb .2	Proportional band 2	0 – 9999 digit <sup>1</sup>	0	
dt	Derivative time	0 – 9999 sec	80 sec	
rt	Reset time	0 – 9999 sec	350 sec	
CY 1	Cycle time 1	1.0 – 999.9 sec	20.0 sec	
CY 2	Cycle time 2	1.0 – 999.9 sec	20.0 sec	
db	Contact spacing	0 – 1000 digit <sup>1</sup>	0	
HYS.1	Differential (hysteresis) 1	0 – 9999 digit <sup>1</sup>	1	
HYS.2	Differential (hysteresis) 2	0 – 9999 digit <sup>1</sup>	1	
y 0	Working point	-100 – 100 %	0 %	
y .1	Maximum output	0 – 100 %	100 %	
y .2	Minimum output	-100 to +100 %	-100 %	
dF	Filter time constant	0.0 – 100.0 sec	0.6 sec	
rASd	Ramp slope	0 – 999 °C/h or °C/min <sup>1</sup>	0	

## 7 Alarm messages

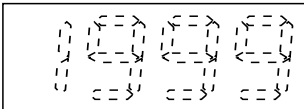
Display	Description	Cause/response
	The process value display flashes "1999".	Over/underrange of the process value. Controller and limit comparators referred to the process value input act in accordance with the configuration of the outputs.



The following events come under the heading over/underrange:

- Probe break/short circuit
- Measurement is outside the control range of the connected probe
- Display overflow

### Measurement circuit monitoring (• = recognised)

Transducer	Measurement over/ underrange	Probe/lead short-circuit	Probe/lead break
Thermocouple	•	-	•
Resistance thermometer	•	•	•
Voltage	2–10V 0–10V	• •	• -
Current	4–20mA 0–20mA	• •	• -

# 8 Technical data

## Thermocouple input

Designation	Range
Fe-Con L	-200 to + 900°C
Fe-Con J EN 60 584	-200 to +1200°C
Cu-Con U	-200 to + 600°C
Cu-Con T EN 60 584	-200 to + 400°C
NiCr-Ni K EN 60 584	-200 to +1372°C
NiCrSi-NiSi N EN 60 584	-200 to +1300°C
Pt10Rh-Pt S EN 60 584	0 — 1768°C
Pt13Rh-Pt R EN 60 584	0 — 1768°C
Pt30Rh-Pt6Rh B EN 60 584	0 — 1820°C
Measurement accuracy: $\leq 0.4\%$ / 100ppm/°C	
Cold junction: Pt100 internal	

## Input for standard signals

Designation	Range
Voltage	0 — 10V, $R_i > 100k\Omega$ 2 — 10V, $R_i > 100k\Omega$ $R_i$ - input resistance
Current	4 — 20mA, voltage drop 1V max. 0 — 20mA, voltage drop 1V max.
Measurement accuracy: $\leq 0.1\%$ / 100ppm/°C	

## Resistance thermometer input

Designation	Range
Pt100 EN 60 751	-200 to +850°C
Pt1000 EN 60 751	-200 to +850°C
KTY11-6	- 50 to +150°C
Measurement accuracy:	
Pt100/1000:	$\leq 0.1\%$ / 50ppm/°C
KTY11-6:	$\leq 1.0\%$ / 50ppm/°C
Sensor lead resistance:	20 $\Omega$ max. per lead
Measurement current:	250 $\mu$ A

## Outputs

Relay:

n.o. (make) contact;

3 A at 250 V AC resistive load;

150 000 operations at rated load

Logic 0/5 V:

Current limiting: 20mA;  $R_{load} \geq 250 \Omega$  min.

Logic 0/12V:

Current limiting: 20mA;  $R_{load} \geq 600 \Omega$  min.

## Supply

110 — 240V -15/+10% AC 48 — 63Hz or

20 — 53V AC/DC 48—63Hz or

10 — 18V DC

## Controller

Controller type	1-setp. controller with limit comparator, 2-setp. controller
Controller structures	P/PD/PI/PID
A/D converter	resolution better than 15 bit
Sampling time	210 msec

### Test voltages (type test)

to EN 61 010, Part 1, March 1994,  
 Type 702040/41: overvoltage Cat. II, pollution degree 2  
 Type 702042/43/44: overvoltage Cat. III, pollution degree 2

**Power consumption** 5 VA max.

**Data backup** EEPROM

### Electrical connection

at rear via plug-in screw terminals  
 conductor cross-section up to 1.5mm<sup>2</sup> (1.0mm<sup>2</sup> for Type 702040/41) or 2x1.5mm<sup>2</sup> (1.0mm<sup>2</sup> for Type 702040/41) with core end sleeves

### Electromagnetic compatibility

EN 50 081-1, EN 50 082-2,  
 NAMUR recommendation NE21

### Housing type

plastic housing for panel mounting to DIN 43 700

### Cleaning the front panel

use warm or hot water (add mildly acidic, neutral or mildly alkaline detergents, if required). Do not use any abrasive cleaning agents or high-pressure cleaners. Limited resistance to organic solvents (e.g. spirits, benzol etc.)

### Housing mounting

in panel to DIN 43 834

### Ambient and storage temperature

0 to 55 °C / -40 to +70 °C

### Climatic conditions

max. 75% rel. humidity, no condensation

### Operating position

any

### Weight (approx.)

75g (702040)	160g (702043)
95g (702041)	200g (702044)
145g (702042)	

### Protection

IP65 (front) to EN 60 529 IP20 (rear)

**Safety standard** to EN 61 010







### **M.K. JUCHHEIM GmbH & Co**

Hausadresse:

Moltkestraße 13-31, 36039 Fulda

Lieferadresse:

Mackenrodtstraße 14, 36039 Fulda

Postadresse:

36035 Fulda, Germany

Telefon: (06 61) 60 03 - 7 27

Telefax: (06 61) 60 03 - 5 08

E-Mail: [mail@jumo.net](mailto:mail@jumo.net)

Internet: [www.jumo.de](http://www.jumo.de)

### **United Kingdom**

JUMO Instrument Co. Ltd.

Temple Bank, Riverway

GB-Harlow

Essex CM20 2TT

Phone (0 12 79) 63 55 33

Fax (0 12 79) 63 52 62

### **USA**

JUMO PROCESS CKONTROL INC.

735 Fox Chase,  
Coatesville, PA 19320

Phone 610-380-8002  
800-554 JUMO

Fax 610-380-8009