

SHARKBITE - REDUCED RUN TEE

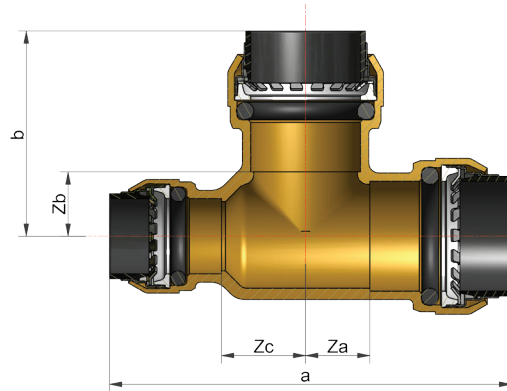
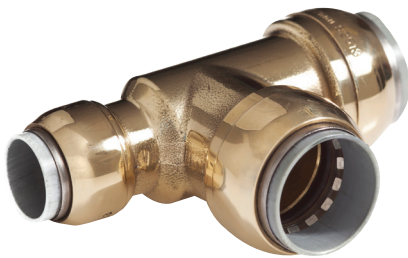

REDUCED RUN TEE							
SIZE	CODE	QTY	a	Za	b	Zb	Zc
22mm x 15mm x 22mm	SB03221522	5*	83mm	13mm	42mm	13mm	17mm

*Singles also available - add -s to the code

WORKING PRESSURES AND TEMPERATURES

SIZE	PIPE	PRESSURE/TEMPERATURE			
10mm	PEX or PB	12 Bar / - 20°C	12 Bar / 20°C	6 Bar / 65°C	6 Bar / 95°C
	Copper	16 Bar / - 24°C	16 Bar / 30°C	10 Bar / 65°C	6 Bar / 95°C
15mm	PEX or PB	12 Bar / - 20°C	12 Bar / 20°C	6 Bar / 65°C	6 Bar / 95°C
	Copper/Carbon Steel	20 Bar / - 24°C	20 Bar / 30°C	16 Bar / 65°C	10 Bar / 120°C
22mm	PEX or PB	12 Bar / - 20°C	12 Bar / 20°C	6 Bar / 65°C	6 Bar / 95°C
	Copper/Carbon Steel	20 Bar / - 24°C	20 Bar / 30°C	16 Bar / 65°C	10 Bar / 120°C
28mm	PEX or PB	12 Bar / - 20°C	12 Bar / 20°C	6 Bar / 65°C	6 Bar / 95°C
	Copper/Carbon Steel	20 Bar / - 24°C	20 Bar / 30°C	16 Bar / 65°C	10 Bar / 120°C
35mm	Copper/PEX/Carbon Steel	16 Bar / - 24°C	16 Bar / 30°C	10 Bar / 65°C	6 Bar / 95°C
42mm	Copper/PEX/Carbon Steel	16 Bar / - 24°C	16 Bar / 30°C	10 Bar / 65°C	6 Bar / 95°C
54mm	Copper/PEX/Carbon Steel	16 Bar / - 24°C	16 Bar / 30°C	10 Bar / 65°C	6 Bar / 95°C



DEMOUNTABLE



ULTRA LOW
LEAD DZR



ELECTRICALLY
CONTINUOUS



INSTANTLY
REUSABLE

FITTING MATERIALS

COMPONENT	MATERIAL
Body	Ultra low lead DZR
O Ring	Ethylene Polypropylene Diene Monomer (EPDM)
15, 22 & 28mm Cartridge	304 Stainless Steel
35, 42 & 54mm Cartridge	Polyphenylsulfone (PPSU)
Grab Ring	316 Stainless Steel
Disconnecting Ring	Acetal Copolymer
Alignment Ring	Nylon 6

GUARANTEE

As a result of the rigorous manufacturing and quality controls and also internal long term test results, all SharkBite fittings are guaranteed against defects in materials or manufacturing for a period of 25 years from the date of purchase.

APPROVALS

SharkBite Fittings are approved by WRAS under approval number 1311328 for 10mm – 28mm & 1409103 for 35mm – 54mm.



PIPE COMPATABILITY

COPPER

Copper pipe manufactured in accordance with BS EN 1057 in sizes 10mm to 54mm. If 10mm annealed Copper pipe is being used, it must be re-calibrated in accordance with Table 4 R250 tolerances in the above standard and a Copper liner installed into the pipe prior to assembly.

PEX

SharkBite cross linked Polyethylene (PEX) manufactured to BS 7291: Part 3 in sizes 10mm to 54mm utilising the specific manufacturer's pipe liner.

POLYBUTYLENE

Polybutylene (PB) manufactured to BS 7291: Part 2 when utilising the specific manufacturer's liner.



CARBON TUBE

Carbon Steel pipe manufactured to EN 10305 – 2.

ELECTRICAL CONTINUITY

SharkBite fittings are TRaC certified to provide electrical continuity when used with Copper or Carbon Steel pipe with the exception of 10mm fittings.