

## EVAL-AD7896CB

### FEATURES

Full-Featured Evaluation Board for the AD7896

EVAL-CONTROL BOARD Compatible

Stand Alone Capability

On-Board Analog Buffering and Reference

Various Linking Options

PC Software for Control and Data Analysis when used with the EVAL-CONTROL BOARD

### INTRODUCTION

This Application Note describes the evaluation board for the AD7896 A/D converter. The AD7896 is a fast 12-bit ADC which operates from a single +2.7V to +5.5V supply. The part incorporates an 8 $\mu$ S successive approximation ADC, an on chip track/hold amplifier, an on-chip clock and a high speed serial interface. Full data on the AD7896 is available in the AD7896 data sheet available from Analog Devices and should be consulted in conjunction with this Application Note when using the Evaluation Board.

On-board components include an AD780 which is a pin programmable +2.5V or +3V ultra high precision bandgap reference, a REF195 which is a +5V reference and an AD713 quad op-amp used to buffer and bias (if required) the analog input. There are various link options which are explained in detail on page 2.

Interfacing to this board is through a 96-way connector. This 96-way connector is compatible with the EVAL-CONTROL BOARD which is also available from Analog Devices.

External sockets are provided for the CONVST input, SCLK input, SDATA output, BUSY output and the VIN input.

### OPERATING THE AD7896 EVALUATION BOARD

#### Power Supplies

Since the AD7896  $V_{DD}$  is also used as the voltage reference for the converter, two high quality references are included on the board. The REF195 supplies +5V and the AD780 supplies +3V. These references are used to supply the  $V_{DD}$  for the AD7896. Link option LK13 determines which voltage reference is used as the AD7896 supply voltage.

When using this evaluation board with the EVAL-CONTROL BOARD all other supplies are provided from the EVAL-CONTROL BOARD through the 96 way connector.

When using the board as a stand alone unit external supplies must be provided. This evaluation board has five power supply inputs:  $V_{DD}$ , AGND, +12V, -12V and AGND.  $V_{DD}$  is used to supply the 74HC08 AND gate. +12V and -12V are used to supply the AD780 and REF195 voltage references and the AD713 quad op-amp. Both of the AGND inputs are connected to the AGND plane.

The supplies are decoupled to AGND with 47 $\mu$ F tantalum and 0.1 $\mu$ F ceramic disc capacitors at the point where they arrive on the eval board. The supply pins of each analog device are also decoupled to AGND with 10 $\mu$ F tantalum and a 0.1 $\mu$ F ceramic capacitor.

Extensive ground planes are used on this board to minimize the effect of high frequency noise interference. There are two ground planes, AGND and DGND. These are connected at one location, close to the AD7896.

FIG. 1: FUNCTIONAL BLOCK DIAGRAM

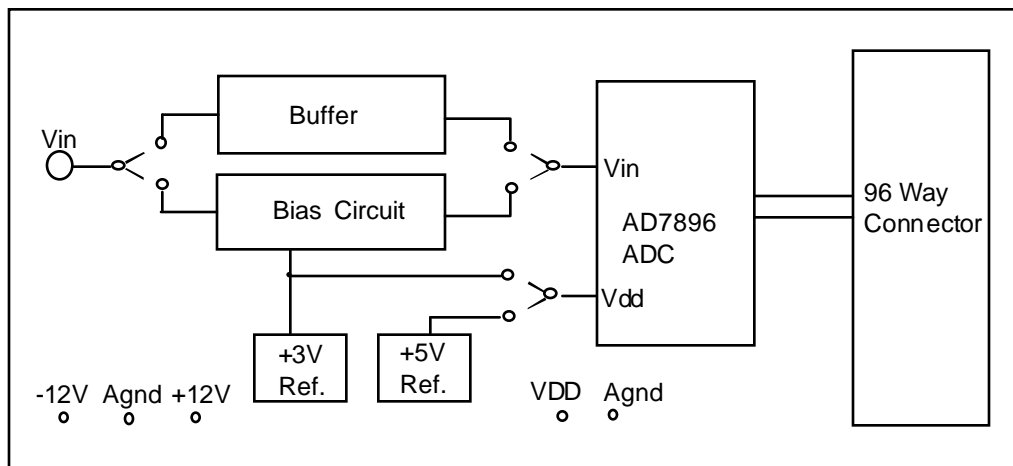

REV. 0

Information furnished by Analog Devices is believed to be accurate and reliable. However, no responsibility is assumed by Analog Devices for its use, nor for any infringements of patents or other rights of third parties which may result from its use. No license is granted by implication or otherwise under any patent or patent rights of Analog Devices.

# EVAL-AD7896CB

## Link and Switch Options

There are twelve link options which must be set for the required operating setup before using the evaluation board. The functions of these options are outlined below.

Link No.	Function.
LK1	This link option is used to select the source of the VDD supply for the 74HC08 AND gate. With this link "IN" V <sub>DD</sub> is supplied by the EVAL-CONTROL BOARD. With this link "OUT" V <sub>DD</sub> must be supplied from an external source through the power connector, J2.
LK2	This link option is used to select the source of the +12V supply. In position A, the +12V is supplied from the EVAL-CONTROL BOARD through the 96 way connector. In position B, the +12V is supplied from an external source through the power connector, J3.
LK3	This link option is used to select the source of the -12V supply. In position A, the -12V is supplied from the EVAL-CONTROL BOARD through the 96 way connector. In position B, the -12V is supplied from an external source through the power connector, J3.
LK4	This link option is used to direct the signal from the Vin socket (SK1) to an input buffer or a bias circuit. With this link in position A, the analog input is directed to the input buffer. With this link in position B, the analog input is directed to the bias circuit.
LK5	This link option adds a 50Ω termination to AGND at the Vin socket. In most applications this link will be left unconnected. If a 50Ω termination is required this link should be connected.
LK6	This link option is used to select between the input buffer or the bias circuit as the signal source for the AD7896. With this link in position A, the bias circuit is selected as the signal source. With this link in position B, the input buffer is selected as the signal source.
LK7	This link selects the bias voltage for the bias circuit. With this link in position A, the full AD780 output voltage is applied to the bias circuit. With this link in position B, the AD780 output voltage is halved by the resistor divider before being applied to the bias circuit.
LK8	This link option is permanently "IN" when evaluating AD7896 parts. This connects the AD780 output pin to the bias circuit.
LK9	This link option selects a 2.5V or 3.0V reference from the AD780. With this link "IN", the AD780 produces a 3V output. Use this option to supply the AD7896 when evaluating with a 3V supply. With this link "OUT", the AD780 produces a 2.5V output. Use this option to supply the bias circuit when evaluating the AD7896 with a 5V supply (generated by the REF195 voltage reference).
LK10	This link option selects the source of the <u>CONVST</u> input. This link should be in position A when using an external <u>CONVST</u> signal. This link option should be in position B when using the <u>CONVST</u> signal from the EVAL-CONTROL BOARD.
LK11	This link option selects the destination of the BUSY output. When this link is in position A the BUSY output is directed to the external socket. When this link is in position B the BUSY output is directed to the EVAL-CONTROL BOARD.
LK12	This link option selects the source of the SCLK input. When this link is in position A the SCLK input is provided by the external socket. When this link is in position B the SCLK input is provided by the EVAL-CONTROL BOARD.
LK13	This link option selects the voltage supply for the AD7896. With this link in position A the part is supplied by the +5V generated by the REF195 voltage reference. When using this option please ensure that +2.5V is being applied to the bias circuit if it is being used ( LK7 - A, LK8 - IN, LK9 - OUT). With this link in position B, the part is supplied by the AD780 output voltage. When using this option please ensure that the AD780 is producing +3V (LK9 - IN), and that 1.5V is being applied to the bias circuit if it is being used (LK7 - B, LK8 - IN, LK9 - IN).

**SET-UP CONDITIONS**

Care should be taken before applying power and signals to the evaluation board to ensure that all link positions are as per the required operating mode. Table I shows the position in which all the links are set when the evaluation board is sent out.

**Table I. Initial Link and Switch Positions**

Link No.	Position	Function.
LK1	IN	74HC08 $V_{DD}$ supplied from EVAL-CONTROL BOARD.
LK2	A	+12V supplied from EVAL-CONTROL BOARD.
LK3	A	-12V supplied from EVAL-CONTROL BOARD.
LK4	B	This directs the signal applied to the Vin socket (SK1) to the bias circuit.
LK5	IN	50 $\Omega$ termination is selected at the Vin socket.
LK6	A	This selects the output of the bias circuit as the input to the Vin pin of the AD7896
LK7	A	Provides 2.5V dc level for the bias circuit.
LK8	IN	AD780 reference output is applied to the bias circuit.
LK9	OUT	This selects a 2.5V output from the AD780 voltage reference.
LK10	B	<u>CONVST</u> is supplied from the EVAL-CONTROL BOARD.
LK11	B	BUSY is directed to the EVAL-CONTROL BOARD.
LK12	B	SCLK is supplied from the EVAL-CONTROL BOARD.
LK13	A	This selects the +5V from the REF195 as the supply for the AD7896.

# EVAL-AD7896CB

## EVALUATION BOARD INTERFACING

Interfacing to the evaluation board is via a 96-way connector, J1. J1 is used to connect the evaluation board to the EVAL-CONTROL BOARD or other system. The pinout for the J1 connector is shown in Figure 2 and its pin designations are given in Table II.

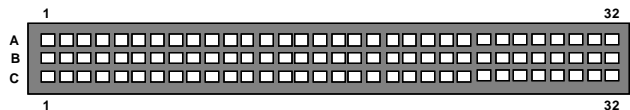

Figure 2. Pin Configuration for the 96-Way Connector, J1

### 96-Way Connector Pin Description

- DR0** Data Receive Zero. Serial data from the AD7896 SDATA output is transferred to this pin. Sixteen bits of serial data are provided with four leading zeroes followed by the 12 bits of conversion data. On the sixteenth falling edge of SCLK, the SDATA line is held for the data hold time and then disabled (three stated). Output data coding is straight binary .
- DGND** Digital Ground. These lines are connected to the digital ground plane on the evaluation board. It allows the user to provide the digital supply via the connector along with the other digital signals.
- FL0** Flag zero. This is a logic input and is connected to the CONVST logic input on the device via LK10. On the falling edge of this input the track/hold amplifier goes into its hold mode and conversion is initiated. If CONVST is low at the end of conversion, the part goes into power down mode. In this case, the rising edge of CONVST "wakes up" the part.
- IRQ2** Interrupt Request 2. This is a logic output and is connected to the BUSY logic output on the device via LK11. This output will go high on the falling edge of CONVST and will return low when the conversion is complete.
- SCLK0** Serial Clock Zero. This is a continuous clock which is converted to sixteen clock pulses by the 74HC08 AND gate. This is done by ANDing the continuous clock and the RFS/TFS framing pulses. The sixteen clock pulses are connected to the SCLK pin of the AD7896 via LK12
- AGND** Analog Ground. These lines are connected to the analog ground plane on the evaluation board.
- AV<sub>DD</sub>** Analog +5V Supply. These lines are connected to the V<sub>DD</sub> supply line on the board via LK1.
- +12V** +12V Supply. This line is connected to the +12V supply line on the board via LK2.
- 12V** -12V Supply. This line is connected to the -12V supply line on the board via LK3.

Table II. 96-Way Connector Pin Functions.

	ROW A	ROWB	ROWC
1			
2			
3			
4	DGND	DGND	DGND
5			DR0
6	TFS0		RFS0
7	SCLK0		SCLK0
8			
9			
10			
11			
12	DGND	DGND	DGND
13			
14			
15			
16	DGND	DGND	DGND
17	FL0		IRQ2
18			
19			
20	DGND	DGND	DGND
21	AGND	AGND	AGND
22	AGND	AGND	AGND
23	AGND	AGND	AGND
24	AGND	AGND	AGND
25	AGND	AGND	AGND
26	AGND	AGND	AGND
27		AGND	
28		AGND	
29	AGND	AGND	AGND
30	-12V	AGND	+12V
31			
32	AVDD	AVDD	AVDD

Note : The unused pins of the 96-way connector are not shown.

**SOCKETS**

There are five input sockets relevant to the operation of the AD7896 on this evaluation board. The function of these sockets is outlined in Table III.

**Table III. Socket Functions**

Socket	Function
SK1	Sub-Miniature BNC Socket for $V_{IN}$ .
SK2	Sub-Miniature BNC Socket for <u>CONVST</u> input.
SK3	Sub-Miniature BNC Socket for BUSY output.
SK4	Sub-Miniature BNC Socket for SDATA output.
SK5	Sub-Miniature BNC Socket for SCLK input.

**CONNECTORS**

There are three connectors on the AD7896 evaluation board as outlined in Table IV.

**Table IV. Connector Functions**

Connector	Function
J1	96-Way Connector for Parallel Interface connections.
J2	External $V_{DD}$ (for the 74HC08) & AGND power connector.
J3	External +12V, -12V & AGND power connector.

**OPERATING WITH THE EVAL-CONTROL BOARD**

The evaluation board can be operated in a stand-alone mode or operated in conjunction with the EVAL-CONTROL BOARD. This EVAL-CONTROL BOARD is available from Analog Devices under the order entry "EVAL-CONTROL BOARD". When operated with this control board, all supplies (except the AD7896  $V_{DD}$ ) and control signals for operating the AD7896 are provided by the EVAL-CONTROL BOARD when it is run under control of the AD7896 software which is provided with the AD7896 evaluation board package. This EVAL-CONTROL BOARD will also operate with all Analog Devices evaluation boards which end with the letters CB in their title.

The 96-way connector on the EVAL-AD7896CB plugs directly into the 96-way connector on the EVAL-CONTROL BOARD. No power supplies are required in the system. The EVAL-CONTROL BOARD generates all the required supplies for itself and the EVAL-AD7896CB. The EVAL-CONTROL BOARD is powered from a 12V ac transformer. This is a standard 12V ac transformer capable of supplying 1A current and is available as an accessory from Analog Devices under the following part numbers:

- EVAL-110VAC-US: For use in the U.S. or Japan
- EVAL-220VAC-UK: For use in the U.K.
- EVAL-220VAC-EU: For use in Europe

These transformers are also available for other suppliers including Digikey (U.S.) and Campbell Collins (U.K.).

Connection between the EVAL-CONTROL BOARD and the serial port of a PC is via a standard RS-232 cable which is provided as part the EVAL-CONTROL BOARD package. Please refer to the manual which accompanies the EVAL-CONTROL BOARD for more details on the EVAL-CONTROL BOARD package.

# EVAL-AD7896CB

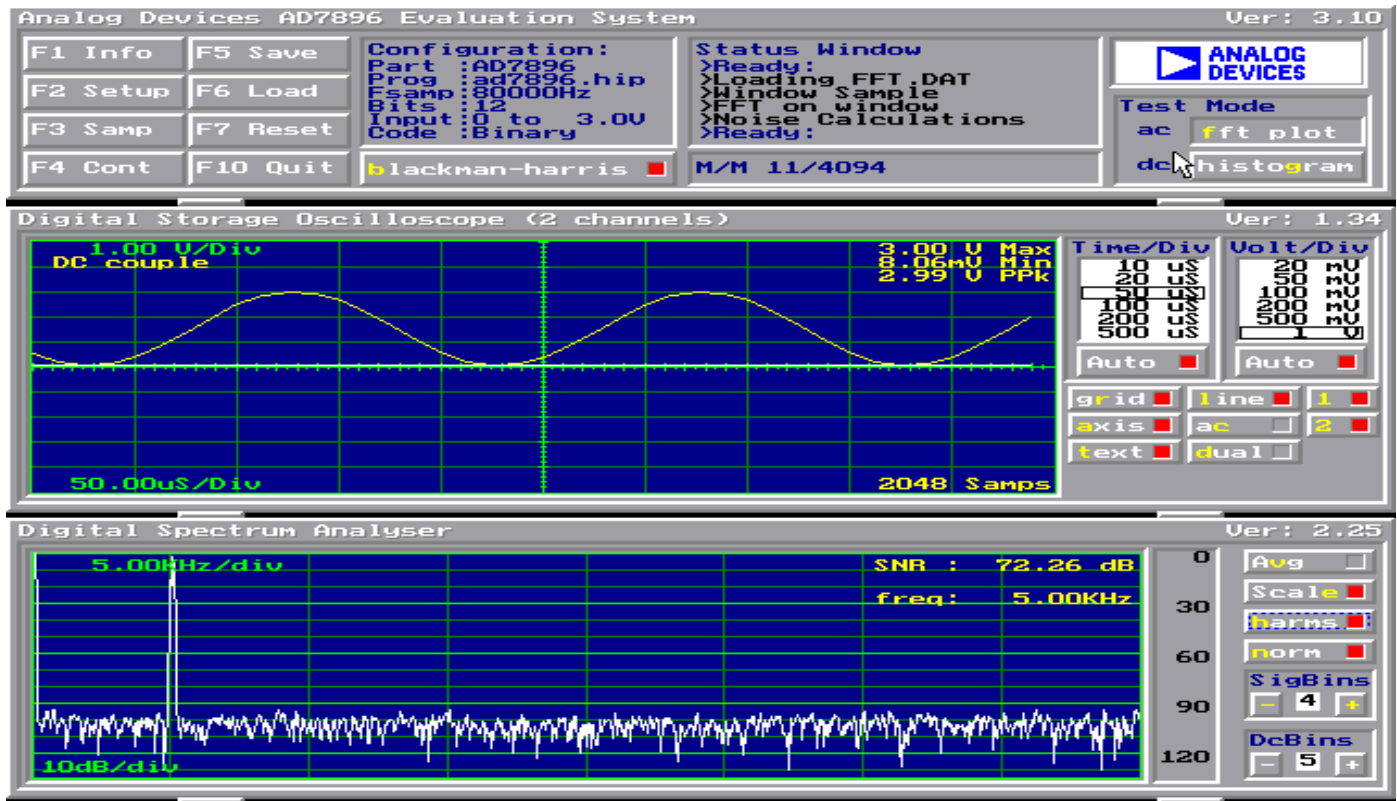

Figure 3. FFT Screen

## SOFTWARE DESCRIPTION

Included in the EVAL-AD7896CB evaluation board package is a PC-compatible disk which contains software for controlling and evaluating the performance of the AD7896 when it is operated with the EVAL-CONTROL BOARD. The EVAL-AD7896CB Demonstration/Evaluation Software runs under DOS 4.0 or later and requires a minimum of a 386-based machine with 400kB of base RAM and 500kB of free hard disk space. The user interface on the PC is a dedicated program written especially for the AD7896.

The disk which accompanies the EVAL-AD7896CB contains several files. The user should create a new directory on the main PC drive and label this "AD7896". Then, all files on the EVAL-AD7896CB disk should be copied into this directory. The Mouse Driver on the PC should be enabled before running the software. If this has not been loaded, the program will not run.

To run the software, simply make the AD7896 directory the current directory and type "go". When the evaluation program starts, the user sees the screen shown on Figure 3 (without any FFT or scope waveforms). This is the main screen and it is divided into three parts. The top part provides the main control interface for the AD7896 evaluation software. The middle part of the main screen functions as a Digital Storage Oscilloscope and the bottom part of the main screen operates as either a Digital Spectrum Analyzer or a Histogram analyzer.

Each part of the screen has several buttons that can be pressed by using the mouse or the keyboard. To press a button using the mouse, simply use it to move the on-screen pointer to the button to be activated and click. To use the keyboard, simply press the appropriate key as highlighted on the button. Lower case letters must be used. When a button is pressed, it is highlighted on the

screen. The next button can be highlighted by using the Tab key or the previous button by holding down the shift key and the Tab key together. The highlighted button can also be pressed by pressing the space bar. Pressing the ESC key halts any operation currently in progress. In this document, if a button can be activated from the keyboard then the key used is shown in bold in the button name. For example, "no prog" has the "p" highlighted in bold, indicating that the button can be activated by pressing the p key.

Some buttons have a red indicator. A red indicator on the button means that the function associated with that button is on. Absence of the red indicator light means that the function associated with the button is off. The on/off status of these buttons is changed simply by selecting the button.

## Setting up the EVAL-CONTROL BOARD

When the software is run, the "F2 Setup" button in the top left of the screen should be selected to pop up the setup menu. This menu sets up the EVAL-CONTROL BOARD for use with the EVAL-AD7896CB.

Firstly, a configuration file must be chosen. The configuration file contains the default configuration information for the EVAL-CONTROL BOARD, the Digital Spectrum Analyzer and the Digital Storage Oscilloscope. It also tells the AD7896.EXE software which .HIP file to download to the ADSP-2111. The .HIP file contains the DSP code which is executed by the ADSP-2111. Normally, the "no prog" button is off, so when the configuration file is loaded, the .HIP file is automatically downloaded to the ADSP-2111. However, if the "no prog" button is on, then the .HIP file is not downloaded to the ADSP-2111.

There are two configuration files for the AD7896. These are AD7896-3 and AD7896-5. If the AD7896 device is being evaluated using a 3V VDD then the AD7896-3 config file is chosen, alternately if the part is being evaluated using a 5V VDD then the AD7896-5 config file is chosen. For example, if evaluating with a 5V VDD, the mouse or the keyboard is used to highlight the "AD7896-5" option and the "load" button is pressed.

After the configuration file is loaded, the sample rate and number of samples can be changed. The CONVST frequencies are limited to frequencies of the form 16 MHz/N, where N is an integer in the range 1 to 65536 with a maximum conversion time for the AD7896 being 8uS. If a frequency other than one of these frequencies is chosen, then the EVAL-CONTROL BOARD generates the next lowest available frequency.

### Main Screen

The top left part of the main screen contains eight buttons which are selected using the mouse or by using the function keys from the keyboard. These buttons and the actions they perform are:

F1: Info. Activating this button provides information on the software.

F2: Setup . Pressing this button pops up the Setup Menu. This menu is described above.

F3: Samp. When this key is pressed, the software causes the AD7896 to perform a number of conversions as determined by the setup menu (see above). The data from these conversions is then analyzed by the AD7896 evaluation software. Another set of samples may be taken by pressing the F3 key again.

F4: Cont. Pressing this button causes the software to repeatedly perform conversions and analyze them. Once the conversions and analysis has been done for one set of samples, the software automatically repeats the process. It continues to do this until the ESC key is pressed.

F5: Save. This saves a set of samples to a file for use either at a later date or with other software. The samples can be saved either as "volts", "ints" or "binary". The format of all these files is ASCII text. Note that the AD7896 software can only load files saved in the "ints" format. Files saved in the "volts" and "ints" formats can be used with packages such as Mathcad. Files saved in the "binary" format are for viewing purposes only.

F6: Load. This allows the user to load data from a file with a .DAT extension. Only data that was saved as ints can be loaded and analyzed. A configuration file must be loaded via the "F2 Setup" menu before the data file can be analyzed. If there is no EVAL-CONTROL BOARD connected to the PC, then the "no prog" button in the "F2 Setup" menu must be on. Once a configuration file has been loaded, the data loaded from the .DAT file is analyzed according to the settings in the "F2 Setup" menu.

F7: Reset. Choosing this option resets the EVAL-CONTROL BOARD.

F10: Quit. This quits the AD7896 evaluation software and returns control to the operating system.

### Information Windows

There are three information windows at the top of the main screen. The left-hand window is the configuration window and gives details about part being evaluated. It shows the name of the

program that has been downloaded to the EVAL-CONTROL BOARD, the sampling frequency, the number of bits, the analog input range of the part and the output code format of the part. The right-hand large window is the Status window. This window provides feedback to the user as to what operations are currently being performed by the software and also displays error messages. Directly underneath the status window is a small window that shows the maximum and minimum values of the most recently captured samples.

### Test Mode

At the top right of the main screen are the Test Mode buttons. These buttons determine what sort of testing is done on the samples captured by the software. Both an ac analysis and dc analysis can be performed. The function of these buttons are:

fft plot Choosing this button causes the Digital Spectrum Analyzer to appear at the bottom of the screen.

histogram: Choosing this button causes the Histogram Analyzer to be displayed at the bottom of the screen.

There is one other button near the top of the screen, beside the "F10 Quit" button. This is:

blackman-harris: When performing a fourier transform of the sampled data, this button determines whether or not the data is windowed by a blackman-harris window before the transform. When this button is on, the data is windowed. When this button is off, the data isn't windowed. See the Digital Spectrum Analyzer section for more details.

# EVAL-AD7896CB

## Digital Storage Oscilloscope.

When samples of data are captured, they are displayed on the Digital Storage Oscilloscope. If the blackman-harris button is turned on then the windowed data is also displayed on the oscilloscope. The 'scope has been designed to act in a similar way as a conventional oscilloscope. To the right of the oscilloscope are several buttons that control the manner in which data is displayed on the 'scope. The timebase for the oscilloscope is automatically chosen by the software if the Time/Div "Auto" button is on. The user can also select the timebase by clicking in the Time/Div window and scrolling up and down through the possible timebases. Similarly, the vertical scale of the oscilloscope is chosen automatically if the Volt/Div "Auto" button is on. The user also has the option of selecting the desired vertical scale in a similar manner to selecting the timebase.

The other buttons associated with the oscilloscope are:

- grid This button toggles the grid display of the oscilloscope on and off.
- axis This button toggles the axis display of the oscilloscope on and off
- text This button toggles the text displayed on the oscilloscope screen on and off.
- line When the line button is on, the displayed samples are joined together by lines. When this button is off, the samples are displayed as points.

ac When this button is on, the dc component of the sampled signal is removed and the signal is displayed. This has the effect of centering the signal vertically on the oscilloscope screen. When this button is off, the dc component is not removed and the signal is displayed with its horizontal axis corresponding to a code of 0. The ac display option is useful for zooming in on a low-level signal that has a large dc offset.

dual When the "dual" button is on, the oscilloscope screen is divided into two parts with the sampled data display centered on one horizontal axis and the windowed data display centered on another. When the "dual" button is off, both traces are centered on the same horizontal axis.

- 1 This button toggles the sampled data trace on and off
- 2 This button toggles the windowed data trace on and off.

## Histogram Analyzer

The histogram analyzer counts the number of occurrences of each code in the captured samples and displays a histogram of these counts. The most frequently occurring code is displayed in the center of the histogram. The analyzer is normally used with a dc input signal and calculates the mean and the standard deviation of the sampled data. The mean and standard deviation are displayed in both volts and in units of the lsb size of the converter. The histogram gives a good indication of the dc noise performance of the ADC. The standard deviation shows directly the noise introduced in the conversion process.

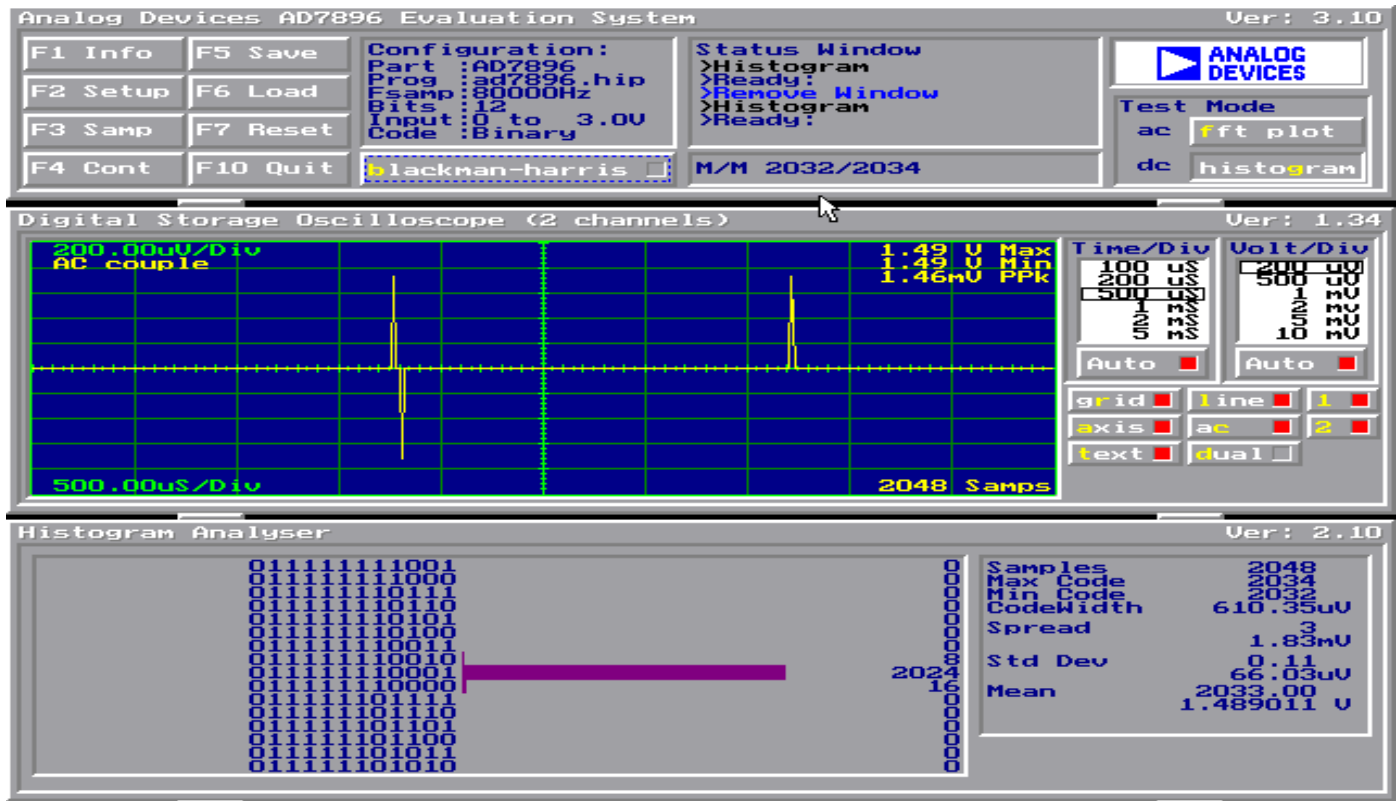

Figure 4. Histogram Screen

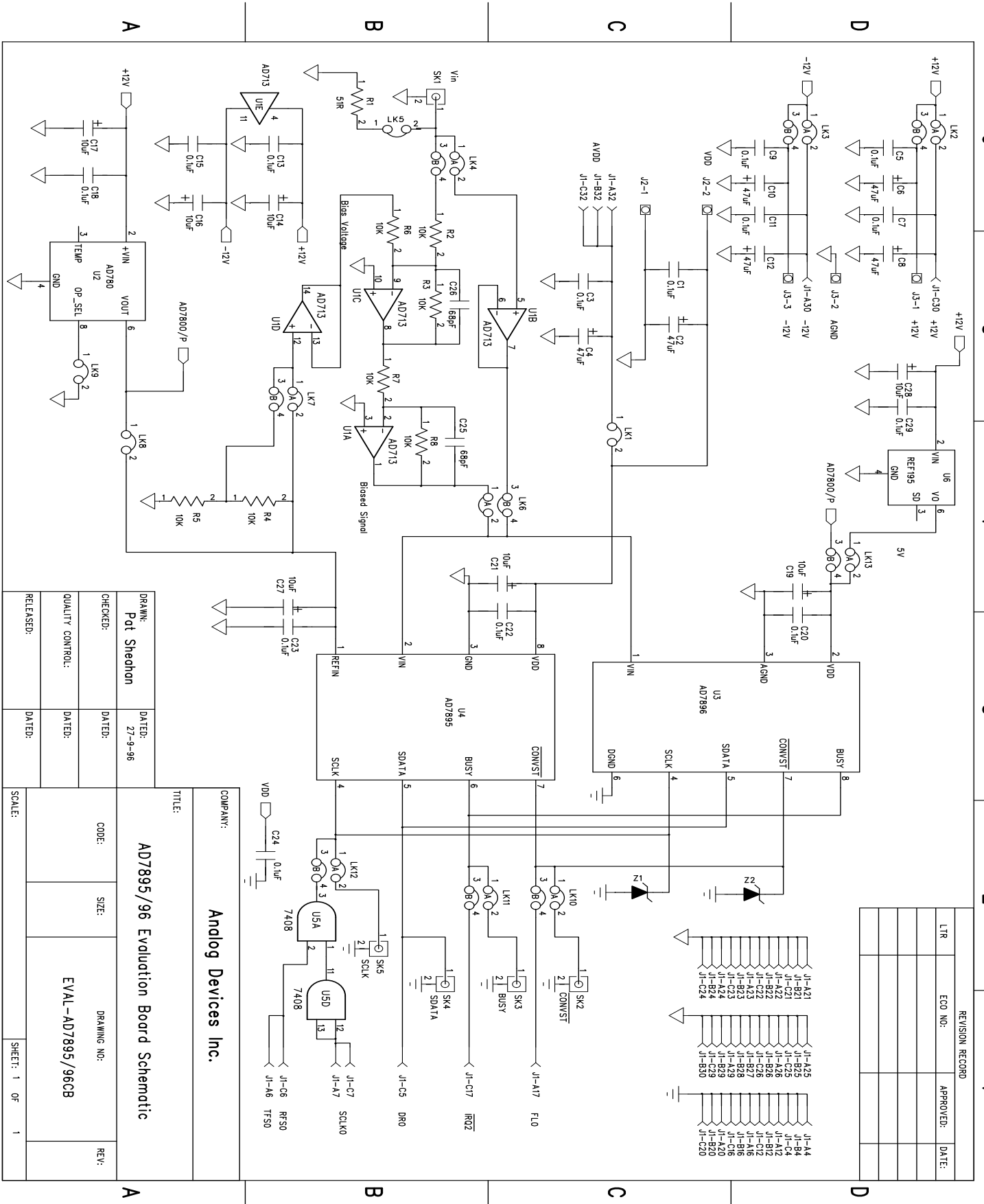

Figure 5. AD7896 Evaluation Board Circuit Diagram

6	5	4	3	2	1
REVISION RECORD					
LTB	ECO NO:	APPROVED:	DATE:		

DRAWN: Pot Sheehan	DATED: 27-9-96
CHECKED:	DATED:
QUALITY CONTROL:	DATED:
RELEASED:	DATED:

COMPANY: Analog Devices Inc.	
TITLE: AD7895/96 Evaluation Board Schematic	
CODE:	SIZE:
DRAWING NO: EVAL-AD7895/96CB	
SCALE:	SHEET: 1 OF 1

# EVAL-AD7896CB

## COMPONENT LISTING AND MANUFACTURERS

Component	Location	Vendor
AD713	U1	Analog Devices
AD780	U2	AnalogDevices
AD7896	U3	AnalogDevices
-----	U4	-----
74HC08	U5	Texas Instruments
REF-195	U6	AnalogDevices
SD103C	Z1 Z2	HewlettPackard

### Capacitors

Component	Location	Vendor
0.1 $\mu$ F Ceramic(X7R $\pm$ 20%)	C1 C3 C5 C7 C9 C11 C13 C15 C18 C20 C22 C23 C24 C29	Philips Mftrs No. CW20C104M
10 $\mu$ F $\pm$ 20% Tantalum (16V)	C14 C16 C17 C19 C21 C27 C28	Mftrs No TAG106MO16
47 $\mu$ F $\pm$ 20% Tantalum (16V)	C2 C4 C6 C8 C10 C12	Mftrs No TAG476MO16
68pF polystyrene	C25 C26	Farnell 105-059

### Resistors

Component	Location	Vendor
51 $\Omega$ $\pm$ 1% 0.25W	R1	Multicomp
10K $\Omega$ $\pm$ 0.1% 0.25W	R2 R3 R4 R5 R6 R7 R8	RC55 Series

### Link Options

Component	Location	Vendor
Pin Headers (1x2 way)	Lk1 Lk5 Lk8 Lk9	Harwin
Pin Headers (2x2 way)	Lk2 Lk3 Lk4 Lk6 Lk7 Lk10 Lk11 Lk12 Lk13	Mftrs No. M20-9993606
Shorting Plugs	Pin Headers (13 required)	Harwin Mftrs No. M7571-05

### Sockets

Component	Location	Vendor
SMB Connectors	SK1 SK2 SK3 SK4 SK5	M/A - Com Greenpar Mftrs No. B65N07G999X99
96 Way 90° DIN41612 Plug	J1	Harting Mftrs No. 09031966921
2 Way Terminal Block	J2	Bulgin RIA
3 Way Terminal Block	J3	Bulgin RIA
Ultra low profile sockets	U1 - U5 (63 required)	Harwin Farnell 519-959

Component	Location	Vendor
Rubber Stick-on Feet	Each Corner	Farnell 148-922

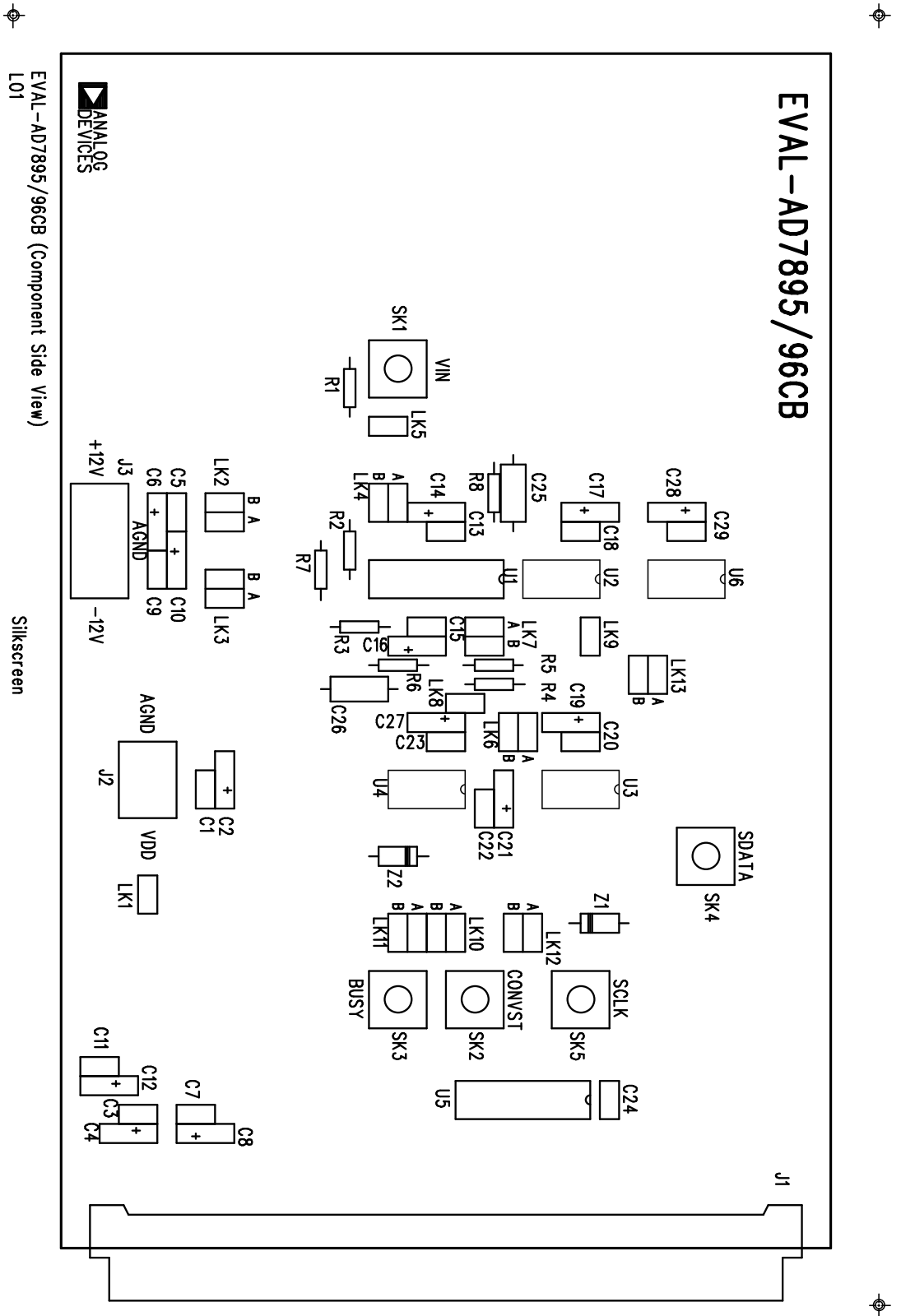

EVAL-AD7895/96CB (Component Side View)  
L01

Silkscreen

Figure 5. Component Layout Diagram