

Engwinklige LED im Dragon Dome Gehäuse (850 nm)
Narrow beam LED in Dragon Dome package (850 nm)
Lead (Pb) Free Product - RoHS Compliant
SFH 4783

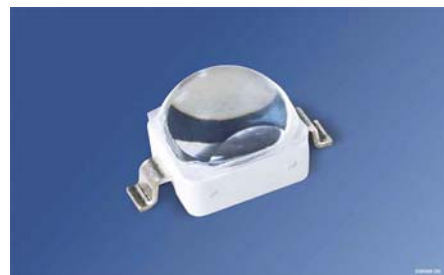

DRAFT - This design is for Reference only.
Subject to change without notice.

Wesentliche Merkmale

- IR-Lichtquelle mit hohem Wirkungsgrad
- Enger Abstrahlwinkel ($\pm 12^\circ$)
- Niedriger Wärmewiderstand (Max. 11 K/W)
- Schwerpunktwellenlänge 850 nm
- ESD sicher bis 2 kV nach ANSI/ESDA/JEDEC JS-001; Klasse 2

Features

- IR lightsource with high efficiency
- Narrow half angle ($\pm 12^\circ$)
- Low thermal resistance (Max. 11 K/W)
- Centroid wavelength 850 nm
- ESD safe up to 2 kV acc. to ANSI/ESDA/ JEDEC JS-001)

Anwendungen

- Infrarotbeleuchtung für Kameras
- Überwachungssysteme
- Beleuchtung für Bilderkennungssysteme

Applications

- Infrared illumination for cameras
- Surveillance systems
- Machine vision systems

Sicherheitshinweise

Je nach Betriebsart emittieren diese Bauteile hochkonzentrierte, nicht sichtbare Infrarot-Strahlung, die gefährlich für das menschliche Auge sein kann. Produkte, die diese Bauteile enthalten, müssen gemäß den Sicherheitsrichtlinien der IEC-Normen 60825-1 und 62471 behandelt werden.

Safety Advices

Depending on the mode of operation, these devices emit highly concentrated non visible infrared light which can be hazardous to the human eye. Products which incorporate these devices have to follow the safety precautions given in IEC 60825-1 and IEC 62471.

Typ Type	Bestellnummer Ordering Code	Strahlstärkegruppierung ¹⁾ ($I_F = 1 \text{ A}$, $t_p = 10 \text{ ms}$) Radiant Intensity Binning ¹⁾ I_e (mW/sr)
SFH 4783	Q65111A4329	≥ 1000 (typ. 2400)

¹⁾ gemessen bei einem Raumwinkel $\Omega = 0.01 \text{ sr}$ / measured at a solid angle of $\Omega = 0.01 \text{ sr}$

Grenzwerte ($T_A = 25\text{ °C}$)**Maximum Ratings**

Bezeichnung Parameter	Symbol Symbol	Wert Value	Einheit Unit
Betriebs- und Lagertemperatur Operating and storage temperature range	T_{op}, T_{stg}	- 40 ... + 100	°C
Sperrschichttemperatur Junction temperature	T_J	+ 125	°C
Sperrspannung Reverse voltage	V_R	1	V
Vorwärtsgleichstrom ¹⁾ Forward current ¹⁾	I_F	1	A
Stoßstrom, $t_p < 1.5\text{ ms}$, $D = 0$ Surge current	I_{FSM}	2	A
Leistungsaufnahme ¹⁾ Power consumption ¹⁾	P_{tot}	2.1	W
Wärmewiderstand Sperrschicht - Lötstelle Thermal resistance junction - soldering point	R_{thJS}	11	K/W

¹⁾ siehe auch maximal zulässiges Durchlassstrom Diagramm /
see maximum permissible forward current diagram

Kennwerte ($T_A = 25\text{ °C}$)**Characteristics**

Bezeichnung Parameter	Symbol Symbol	Wert Value	Einheit Unit
Wellenlänge der Strahlung Wavelength at peak emission $I_F = 1\text{ A}$, $t_p = 10\text{ ms}$	λ_{peak}	860	nm
Schwerpunktwellenlänge der Strahlung Centroid wavelength $I_F = 1\text{ A}$, $t_p = 10\text{ ms}$	$\lambda_{centroid}$	850	nm
Spektrale Bandbreite bei 50% von I_{max} Spectral bandwidth at 50% of I_{max} $I_F = 1\text{ A}$, $t_p = 10\text{ ms}$	$\Delta\lambda$	30	nm
Abstrahlwinkel Half angle	φ	± 12	Grad deg.
Abmessungen der aktiven Chipfläche Dimension of the active chip area	$L \times B$ $L \times W$	1×1	mm ²

Kennwerte ($T_A = 25\text{ °C}$)

Characteristics (cont'd)

Bezeichnung Parameter	Symbol Symbol	Wert Value	Einheit Unit
Schaltzeiten, I_e von 10% auf 90% und von 90% auf 10%, $I_F = 2\text{ A}$, $R_L = 50\ \Omega$ Switching times, I_e from 10% to 90% and from 90% to 10%, $I_F = 2\text{ A}$, $R_L = 50\ \Omega$	t_r / t_f	11 / 14	ns
Durchlassspannung Forward voltage $I_F = 1\text{ A}$, $t_p = 100\ \mu\text{s}$ $I_F = 2\text{ A}$, $t_p = 100\ \mu\text{s}$	V_F V_F	1.65 (< 2.1) 1.9 (< 2.5)	V V
Gesamtstrahlungsfluss Total radiant flux $I_F = 1\text{ A}$, $t_p = 100\ \mu\text{s}$	Φ_e	430	mW
Temperaturkoeffizient von I_e bzw. Φ_e Temperature coefficient of I_e or Φ_e $I_F = 1\text{ A}$, $t_p = 10\text{ ms}$	TC_I	- 0.3	%/K
Temperaturkoeffizient von V_F Temperature coefficient of V_F $I_F = 1\text{ A}$, $t_p = 10\text{ ms}$	TC_V	- 1	mV/K
Temperaturkoeffizient von λ Temperature coefficient of λ $I_F = 1\text{ A}$, $t_p = 10\text{ ms}$	$TC_{\lambda, \text{centroid}}$	+ 0.3	nm/K

Strahlstärke I_e in Achsrichtung¹⁾gemessen bei einem Raumwinkel $\Omega = 0.01$ sr**Radiant Intensity I_e in Axial Direction**at a solid angle of $\Omega = 0.01$ sr

Bezeichnung Parameter	Symbol	Werte Values		Einheit Unit
		-FW	-GW	
Strahlstärke	$I_{e \text{ min}}$	1000	1600	mW/sr
Radiant intensity	$I_{e \text{ max}}$	2000	3200	mW/sr
$I_F = 1$ A, $t_p = 10$ ms				

- ¹⁾ Nur eine Gruppe in einer Verpackungseinheit (Streuung kleiner 2:1) /
Only one bin in one packing unit (variation lower 2:1)

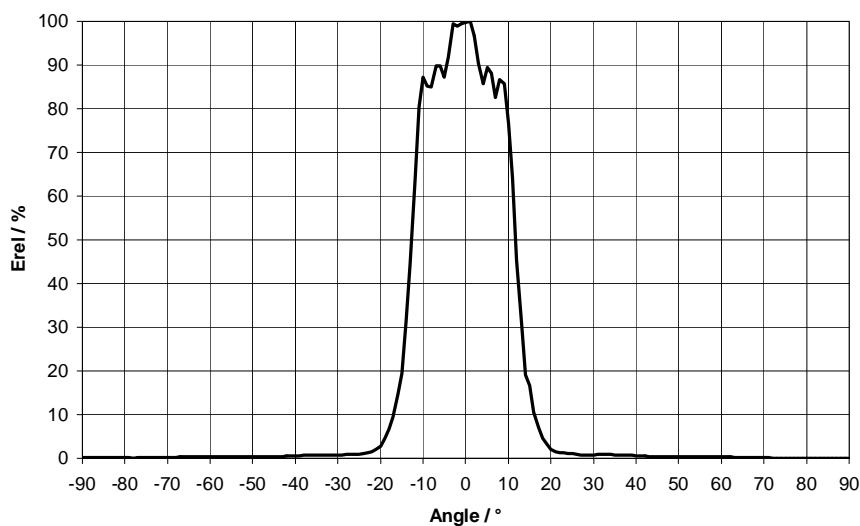
Abstrahlcharakteristik**Radiation Characteristics $I_{\text{rel}} = f(\varphi)$** 

Relative spektrale Emission
Relative Spectral Emission

$I_{rel} = f(\lambda), T_A = 25\text{ °C}, I_F = 1\text{ A}$
 Single pulse, $t_p = 10\text{ ms}$

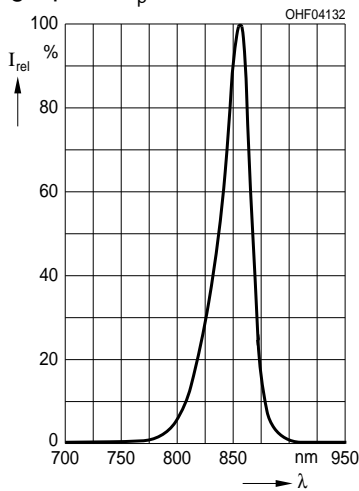

Durchlassstrom
Forward Current

$I_F = f(V_F), T_A = 25\text{ °C}$
 Single pulse, $t_p = 100\text{ }\mu\text{s}$

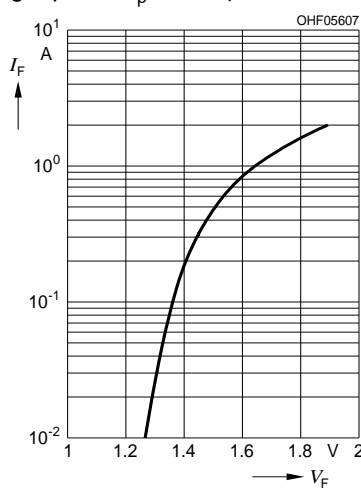

Relativer Gesamtstrahlungsfluss
Relative Total Radiant Flux

$\Phi_e / \Phi_e(1000\text{mA}) = f(I_F), T_A = 25\text{ °C}$
 Single pulse, $t_p = 100\text{ }\mu\text{s}$

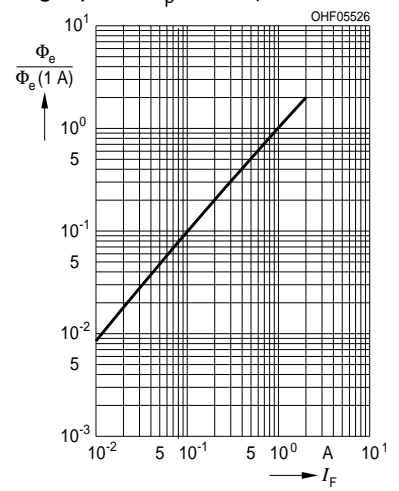

Max. zulässiger Durchlassstrom
Max. Permissible Forward Current

$I_F = f(T_S), R_{thJS} = 11\text{K/W}$

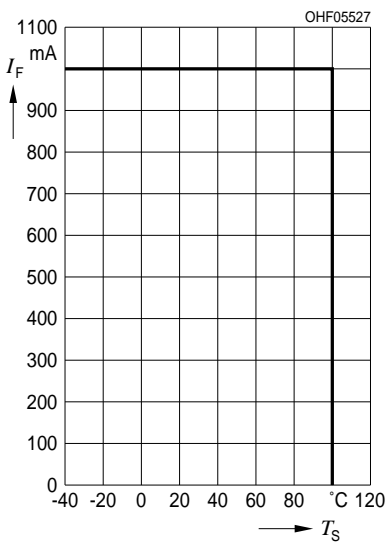

Zulässige Impulsbelastbarkeit
Permissible Pulse Handling

Capability $I_F = f(t_p), T_S = 85\text{ °C}$,
 Duty cycle $D =$ parameter

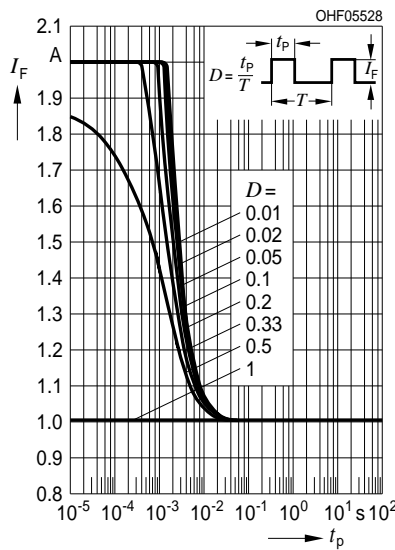

Maßzeichnung¹⁾
 Package Outlines

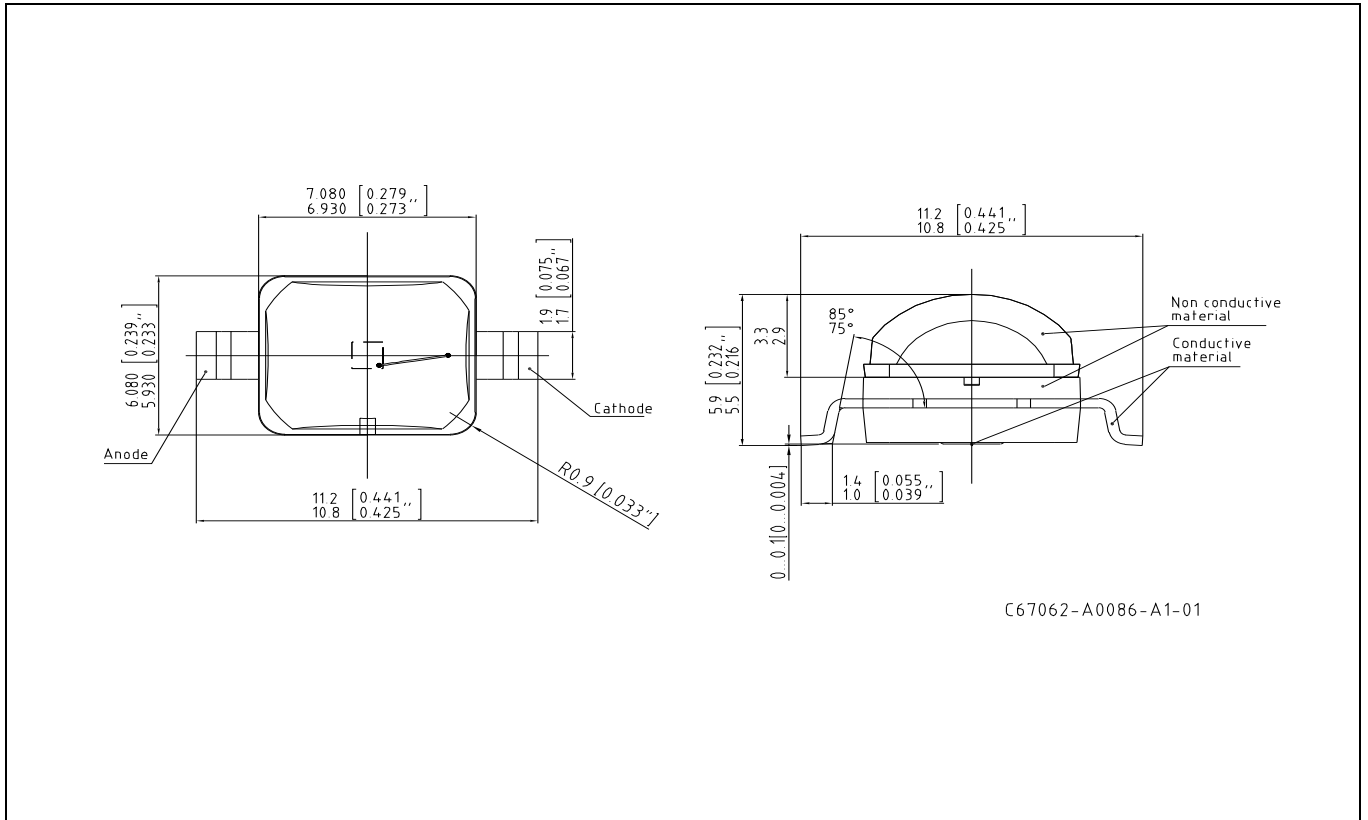

¹⁾ Maße in mm (inch) / Dimensions in mm (inch)

Empfohlenes Lötpaddesign¹⁾ Recommended Solder Pad Design

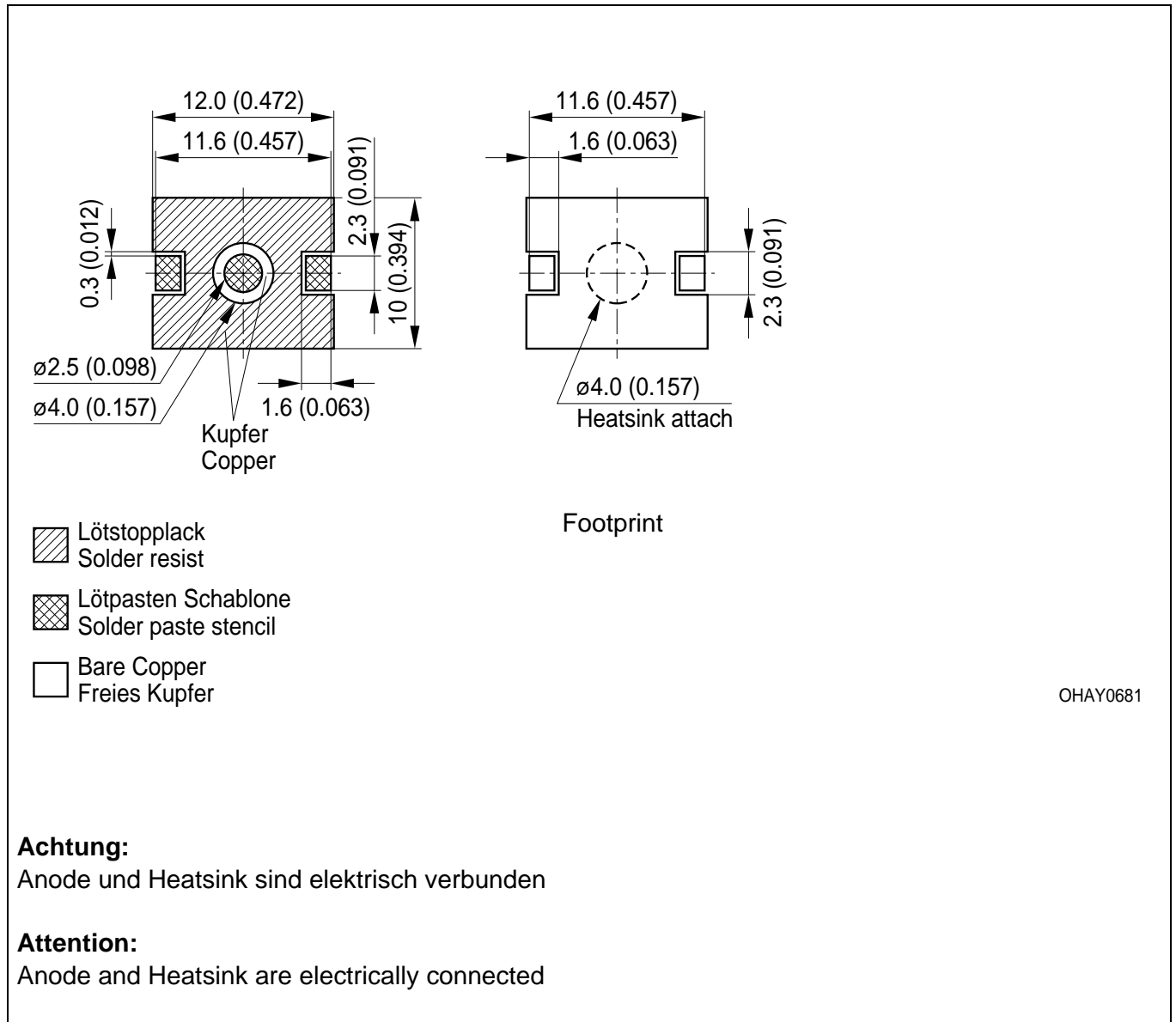

Note: Um eine verbesserte Lötstellenkontaktierung zu erreichen, empfehlen wir, unter Standardstickstoffatmosphäre zu löten. / For superior solder joint connectivity results we recommend soldering under standard nitrogen atmosphere.

¹⁾ Maße in mm (inch) / Dimensions in mm (inch)

Lötbedingungen Soldering Conditions

Reflow Lötprofil für bleifreies Löten Reflow Soldering Profile for lead free soldering

Vorbehandlung nach JEDEC Level 3
Preconditioning acc. to JEDEC Level 3
(nach J-STD-020D.01)
(acc. to J-STD-020D.01)

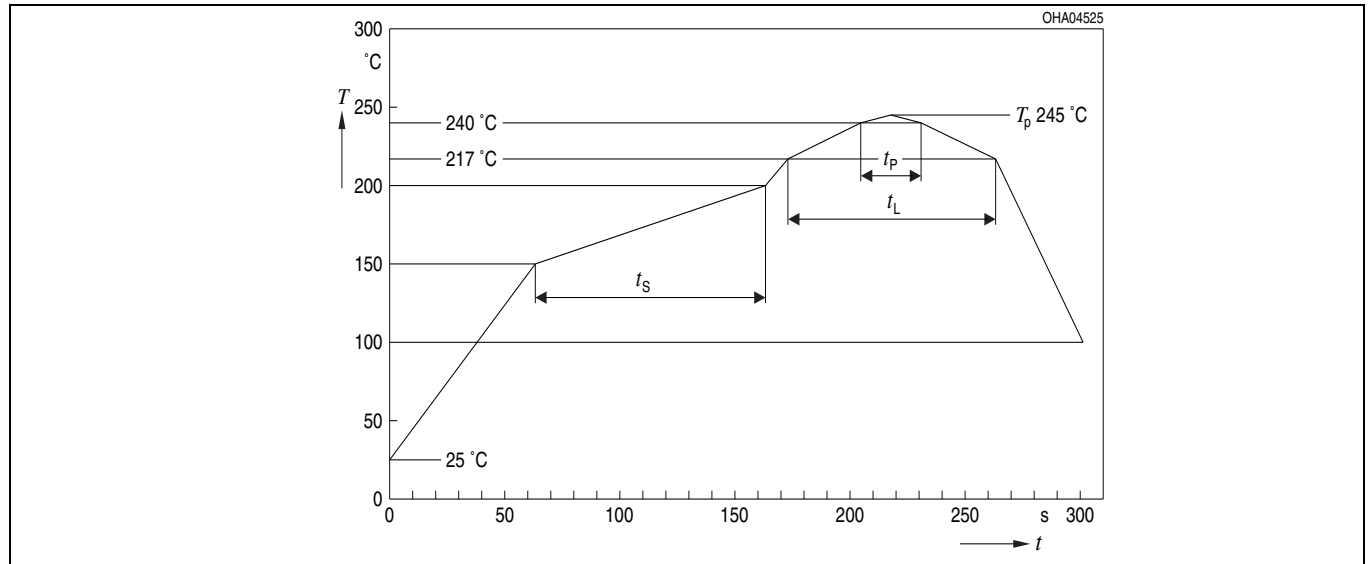

Profileigenschaften Profile Feature	Bleifreier Aufbau / Pb-Free Assembly (SnAgCu)	
	Empfehlung / Recommendation	Grenzwerte / Max. Ratings
Aufheizrate zum Vorwärmen*) / Ramp-up rate to preheat*) 25 °C to 150 °C	2 K / s	3 K / s
Zeit t_s von T_{Smin} bis T_{Smax} / Time t_s from T_{Smin} to T_{Smax} 150 °C to 200 °C	100 s	min. 60 s max. 120 s
Aufheizrate zur Spitzentemperatur*) / Ramp-up rate to peak*) 180 °C to T_p	2 K / s	3 K / s
Liquidustemperatur T_L / Liquidus temperature T_L	217 °C	
Zeit t_L über T_L / Time t_L above T_L	80 s	max. 100 s
Spitzentemperatur T_p / Peak temperature T_p	245 °C	max. 260 °C
Verweilzeit t_p innerhalb des spezifizierten Spitzentemperaturbereichs $T_p - 5$ K / Time t_p within the specified peak temperature range $T_p - 5$ K	20 s	min. 10 s max. 30 s
Abkühlrate*) / Ramp-down rate*) T_p to 100 °C	3 K / s	6 K / s maximum
Zeitspanne von 25 °C bis zur Spitzentemperatur / Time from 25 °C to peak temperature		max. 8 min.

Alle Temperaturen beziehen sich auf die Bauteilmitte, jeweils auf der Bauteiloberseite gemessen / All temperatures refer to the center of the package, measured on the top of the package

* Steigungsberechnung $\Delta T/\Delta t$: Δt max. 5 s; erfüllt über den gesamten Temperaturbereich / slope calculation $\Delta T/\Delta t$: Δt max. 5 s; fulfillment for the whole T-range

Published by
OSRAM Opto Semiconductors GmbH
Leibnizstraße 4, D-93055 Regensburg
www.osram-os.com
© All Rights Reserved.

The information describes the type of component and shall not be considered as assured characteristics. Terms of delivery and rights to change design reserved. Due to technical requirements components may contain dangerous substances. For information on the types in question please contact our Sales Organization.

Packing

Please use the recycling operators known to you. We can also help you – get in touch with your nearest sales office. By agreement we will take packing material back, if it is sorted. You must bear the costs of transport. For packing material that is returned to us unsorted or which we are not obliged to accept, we shall have to invoice you for any costs incurred.

Components used in life-support devices or systems must be expressly authorized for such purpose! Critical components¹, may only be used in life-support devices or systems² with the express written approval of OSRAM OS.

¹ A critical component is a component used in a life-support device or system whose failure can reasonably be expected to cause the failure of that life-support device or system, or to affect its safety or effectiveness of that device or system.

² Life support devices or systems are intended (a) to be implanted in the human body, or (b) to support and/or maintain and sustain human life. If they fail, it is reasonable to assume that the health of the user may be endangered.

Disclaimer

OSRAM OS assumes no liability whatsoever for any use of this document or its content by recipient including, but not limited to, for any design-in activities based on this preliminary draft version. OSRAM OS may e.g. decide at its sole discretion to stop developing and/or finalising the underlying design at any time.

EU RoHS and China RoHS compliant product



此产品符合欧盟 RoHS 指令的要求；

按照中国的相关法规和标准，不含有毒有害物质或元素。