

**Engwinklige LED im MIDLED-Gehäuse**  
**Narrow beam LED in MIDLED package**  
**Lead (Pb) Free Product - RoHS Compliant**

**SFH 4680**  
**SFH 4685**

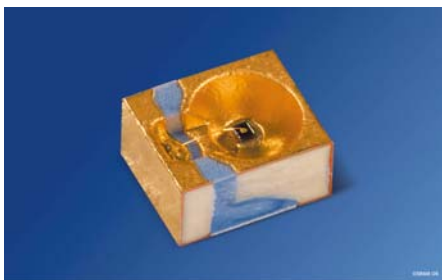

SFH 4680

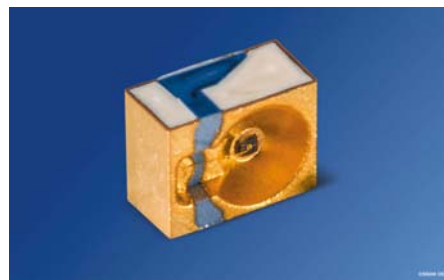

SFH 4685

**Vorläufige Daten / Preliminary Data**

**Wesentliche Merkmale**

- AlGaAs-LED mit typischer Emissionswellenlänge 880 nm
- Enger Abstrahlwinkel ( $\pm 20^\circ$ )
- Geringe Bauhöhe
- Als Toplooker und Sidelooker einsetzbar
- SFH 4680: Gurtung als Toplooker
- SFH 4685: Gurtung als Sidelooker

**Features**

- AlGaAs-LED with typical peak wavelength of 880 nm
- Narrow halfangle ( $\pm 20^\circ$ )
- Low profile component
- Usable as top-looking and side-looking device
- SFH 4680: Taping as Toplooker
- SFH 4685: Taping as Sidelooker

**Anwendungen**

- Sensorik in der Automobiltechnik
- Datenübertragung
- Fernsteuerrung

**Applications**

- Automotive sensors
- Data transmission
- Remote controls

**Sicherheitshinweise**

Je nach Betriebsart emittieren diese Bauteile hochkonzentrierte, nicht sichtbare Infrarot-Strahlung, die gefährlich für das menschliche Auge sein kann. Produkte, die diese Bauteile enthalten, müssen gemäß den Sicherheitsrichtlinien der IEC-Normen 60825-1 und 62471 behandelt werden.

**Safety Advices**

Depending on the mode of operation, these devices emit highly concentrated non visible infrared light which can be hazardous to the human eye. Products which incorporate these devices have to follow the safety precautions given in IEC 60825-1 and IEC 62471.

Typ Type	Bestellnummer Ordering Code	Strahlstärkegruppierung <sup>1)</sup> ( $I_F = 100 \text{ mA}$ , $t_p = 20 \text{ ms}$ ) Radiant Intensity Grouping <sup>1)</sup> $I_e \text{ (mW/sr)}$
SFH 4680	Q65110A1570	$\geq 10 \text{ (typ. 20)}$
SFH 4685	Q65110A1571	$\geq 10 \text{ (typ. 20)}$

<sup>1)</sup> gemessen bei einem Raumwinkel  $\Omega = 0.01 \text{ sr}$  / measured at a solid angle of  $\Omega = 0.01 \text{ sr}$



**ATTENTION - Observe Precautions For Handling - Electrostatic Sensitive Device**

**Grenzwerte  
Maximum Ratings**

Bezeichnung Parameter	Symbol Symbol	Wert Value	Einheit Unit
Betriebs- und Lagertemperatur Operating and storage temperature range	$T_{op}, T_{stg}$	- 40 ... + 100	°C
Sperrspannung Reverse voltage	$V_R$	5	V
Vorwärtsgleichstrom, $T_A \leq 60$ °C Forward current	$I_F$	100	mA
Stoßstrom, $t_p = 10$ µs, $D = 0$ , $T_A = 25$ °C Surge current	$I_{FSM}$	1	A
Verlustleistung $T_A = 25$ °C Power dissipation	$P_{tot}$	180	mW
Wärmewiderstand Sperrschicht - Umgebung bei Montage auf FR4 Platine, Padgröße je 16 mm <sup>2</sup> Thermal resistance junction - ambient mounted on PC-board (FR4), pads size 16 mm <sup>2</sup> each	$R_{thJA}$	340	K/W
Wärmewiderstand Sperrschicht - Lötstelle bei Montage auf Metall-Block Thermal resistance junction - soldering point, mounted on metal block	$R_{thJS}$	180	K/W

**Kennwerte ( $T_A = 25$  °C)**

**Characteristics**

Bezeichnung Parameter	Symbol Symbol	Wert Value	Einheit Unit
Wellenlänge der Strahlung Wavelength at peak emission $I_F = 100$ mA	$\lambda_{peak}$	880	nm
Spektrale Bandbreite bei 50% von $I_{max}$ Spectral bandwidth at 50% of $I_{max}$ $I_F = 100$ mA	$\Delta\lambda$	80	nm

**Kennwerte** ( $T_A = 25\text{ °C}$ )  
**Characteristics** (cont'd)

Bezeichnung Parameter	Symbol Symbol	Wert Value	Einheit Unit
Abstrahlwinkel Half angle	$\varphi$	$\pm 20$	Grad deg.
Aktive Chipfläche Active chip area	$A$	0.09	mm <sup>2</sup>
Abmessungen der aktiven Chipfläche Dimension of the active chip area	$L \times B$ $L \times W$	$0.3 \times 0.3$	mm <sup>2</sup>
Schaltzeiten, $I_e$ von 10% auf 90% und von 90% auf 10%, bei $I_F = 100\text{ mA}$ , $R_L = 50\ \Omega$ Switching times, $I_e$ from 10% to 90% and from 90% to 10%, $I_F = 100\text{ mA}$ , $R_L = 50\ \Omega$	$t_r, t_f$	0.5	$\mu\text{s}$
Durchlassspannung Forward voltage $I_F = 100\text{ mA}$ , $t_p = 20\text{ ms}$ $I_F = 1\text{ A}$ , $t_p = 100\ \mu\text{s}$	$V_F$ $V_F$	1.5 (< 1.8) 3.0 (< 3.8)	V V
Sperrstrom Reverse current $V_R = 5\text{ V}$	$I_R$	not designed for reverse operation	$\mu\text{A}$
Gesamtstrahlungsfluss Total radiant flux $I_F = 100\text{ mA}$ , $t_p = 20\text{ ms}$	$\Phi_{e\text{ typ}}$	23	mW
Temperaturkoeffizient von $I_e$ bzw. $\Phi_e$ , $I_F = 100\text{ mA}$ Temperature coefficient of $I_e$ or $\Phi_e$ , $I_F = 100\text{ mA}$	$TC_I$	- 0.5	%/K
Temperaturkoeffizient von $V_F$ , $I_F = 100\text{ mA}$ Temperature coefficient of $V_F$ , $I_F = 100\text{ mA}$	$TC_V$	- 2	mV/K
Temperaturkoeffizient von $\lambda$ , $I_F = 100\text{ mA}$ Temperature coefficient of $\lambda$ , $I_F = 100\text{ mA}$	$TC_\lambda$	+ 0.25	nm/K

**Strahlstärke  $I_e$  in Achsrichtung<sup>1)</sup>**

gemessen bei einem Raumwinkel  $\Omega = 0.01$  sr

**Radiant Intensity  $I_e$  in Axial Direction**

at a solid angle of  $\Omega = 0.01$  sr

Bezeichnung Parameter	Symbol	Werte Values			Einheit Unit
		-R	-S	-T	
Strahlstärke Radiant intensity $I_F = 100$ mA, $t_p = 20$ ms	$I_{e \text{ min}}$ $I_{e \text{ max}}$	10 20	16 32	25 50	mW/sr mW/sr
Strahlstärke Radiant intensity $I_F = 1$ A, $t_p = 100$ $\mu$ s	$I_{e \text{ typ}}$	130	160	240	mW/sr

<sup>1)</sup> Nur eine Gruppe in einer Verpackungseinheit (Streuung kleiner 2:1) /  
Only one group in one packing unit (variation lower 2:1)

**Abstrahlcharakteristik**

**Radiation Characteristics  $I_{rel} = f(\varphi)$**

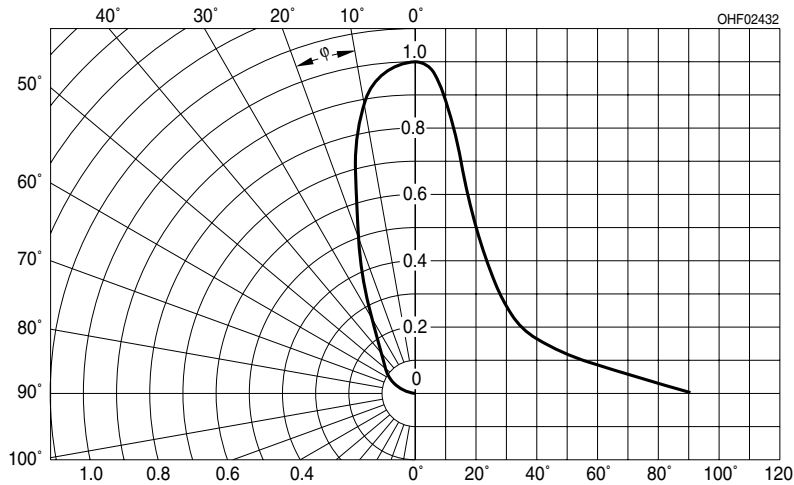

**Relative Spectral Emission**

$I_{rel} = f(\lambda)$

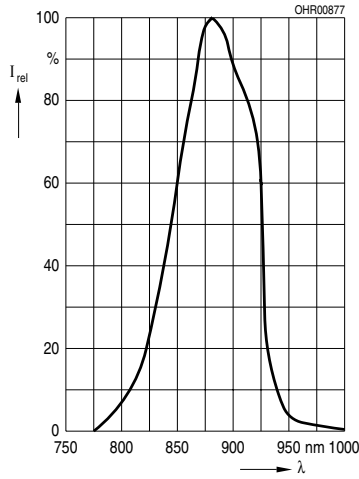

**Radiant Intensity**  $\frac{I_e}{I_e 100 \text{ mA}} = f(I_F)$

Single pulse,  $t_p = 20 \mu\text{s}$

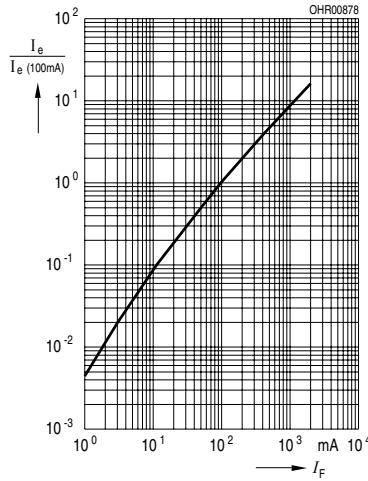

**Max. Permissible Forward Current**

$I_F = f(T_A), R_{thJA} = 340 \text{ K/W}$

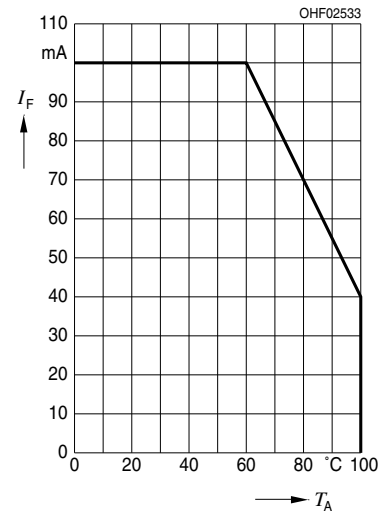

**Forward Current  $I_F = f(V_F)$**

Single pulse,  $t_p = 20 \mu\text{s}$

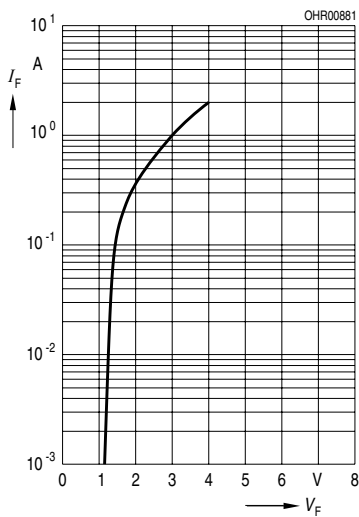

**Permissible Pulse Handling Capability  $I_F = f(\tau), T_A = 25 \text{ °C}$**

duty cycle  $D = \text{parameter}$

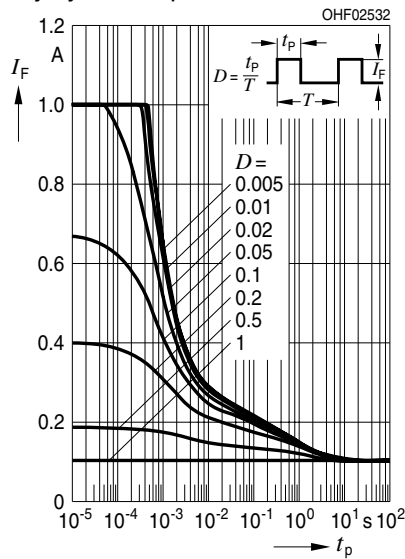

**Maßzeichnung  
Package Outlines**

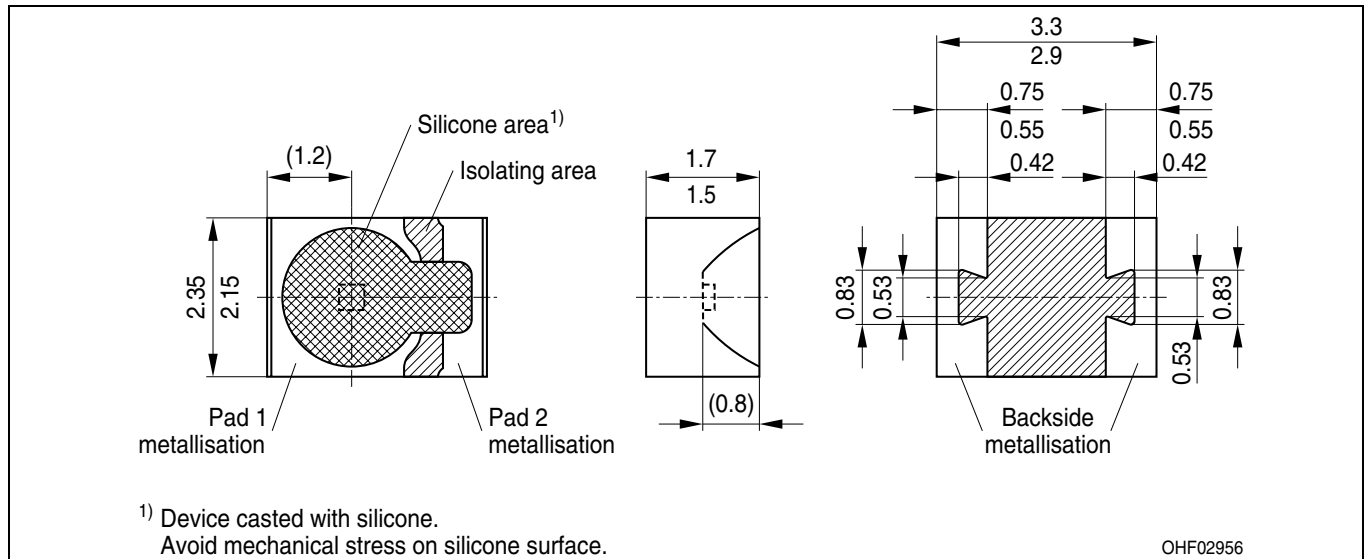

Maße werden in mm angegeben / Dimensions are specified in mm.

Gehäuse / Package	MID mit klarem Silikonverguss / MID casted with clear Silicone
Anschlussbelegung Pin configuration	Pad 1 = Anode / anode Pad 2 = Kathode / cathode

**Gurtung / Polarität und Lage**

Verpackungseinheit 2000/Rolle, ø180 mm  
oder 9000/Rolle, ø330 mm

**Method of Taping / Polarity and Orientation**

Packing unit 2000/reel, ø180 mm  
or 9000/reel, ø330 mm

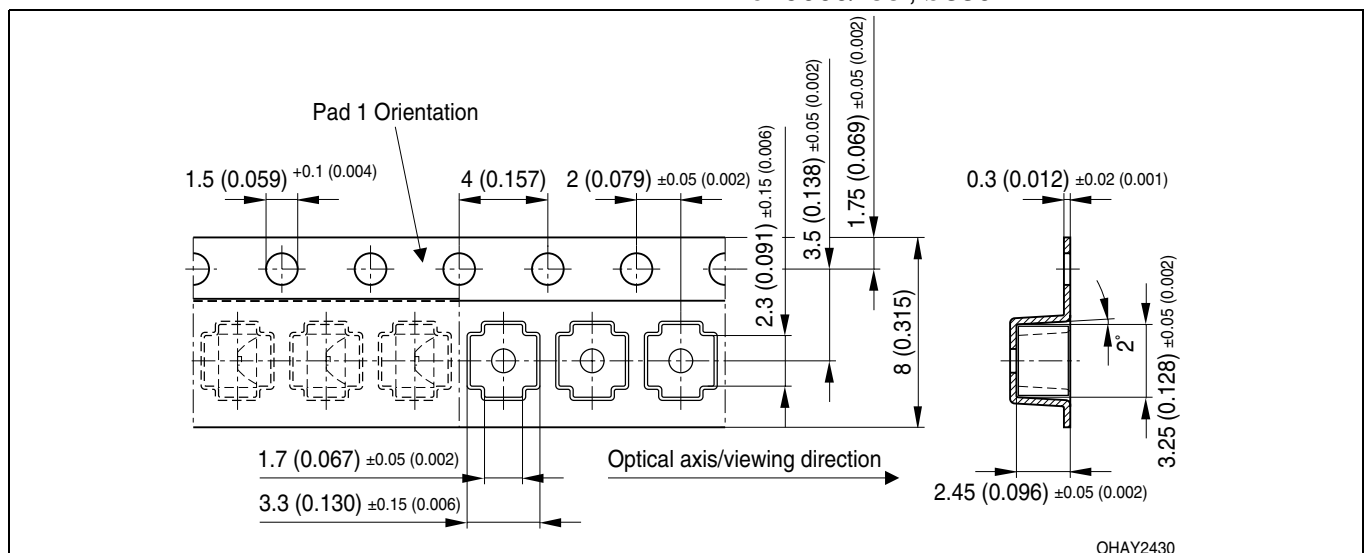

Maße werden wie folgt angegeben: mm (inch) / Dimensions are specified as follows: mm (inch).

**Empfohlenes Lötpaddesign**  
**Recommended Solder Pad Design**

SFH 4680

Padgeometrie für verbesserte Wärmeableitung  
 Pad design for improved heat dissipation

Cu-Fläche > 16 mm<sup>2</sup>  
 Cu-area

 Lötstopplack  
 Solder resist

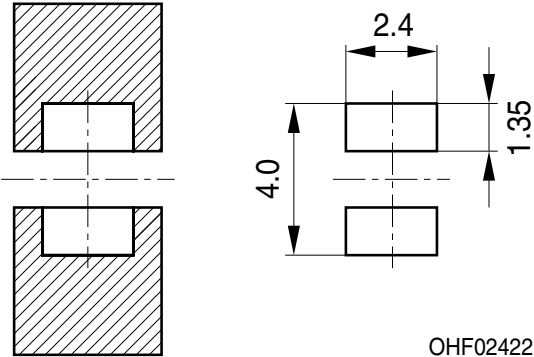

OHF02422

SFH 4685

Padgeometrie für verbesserte Wärmeableitung  
 Pad design for improved heat dissipation

Cu-Fläche > 16 mm<sup>2</sup>  
 Cu-area

 Lötstopplack  
 Solder resist

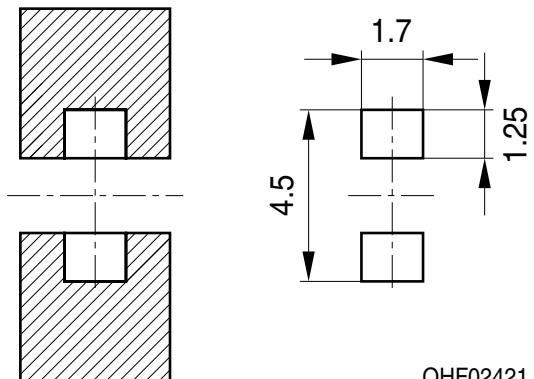

OHF02421

Maße werden in mm angegeben / Dimensions are specified in mm.

**Verarbeitungshinweis:** Das Gehäuse ist mit Silikon vergossen. Mechanischer Stress auf der Bauteiloberfläche sollte so gering wie möglich gehalten werden.

**Handling indication:** The package is casted with silicone. Mechanical stress at the surface of the unit should be as low as possible.

**Lötbedingungen****Soldering Conditions****IR-Reflow Lötprofil für bleifreies Löten****IR Reflow Soldering Profile for lead free soldering**

Vorbehandlung nach JEDEC Level 4

Preconditioning acc. to JEDEC Level 4

(nach J-STD-020C)

(acc. to J-STD-020C)

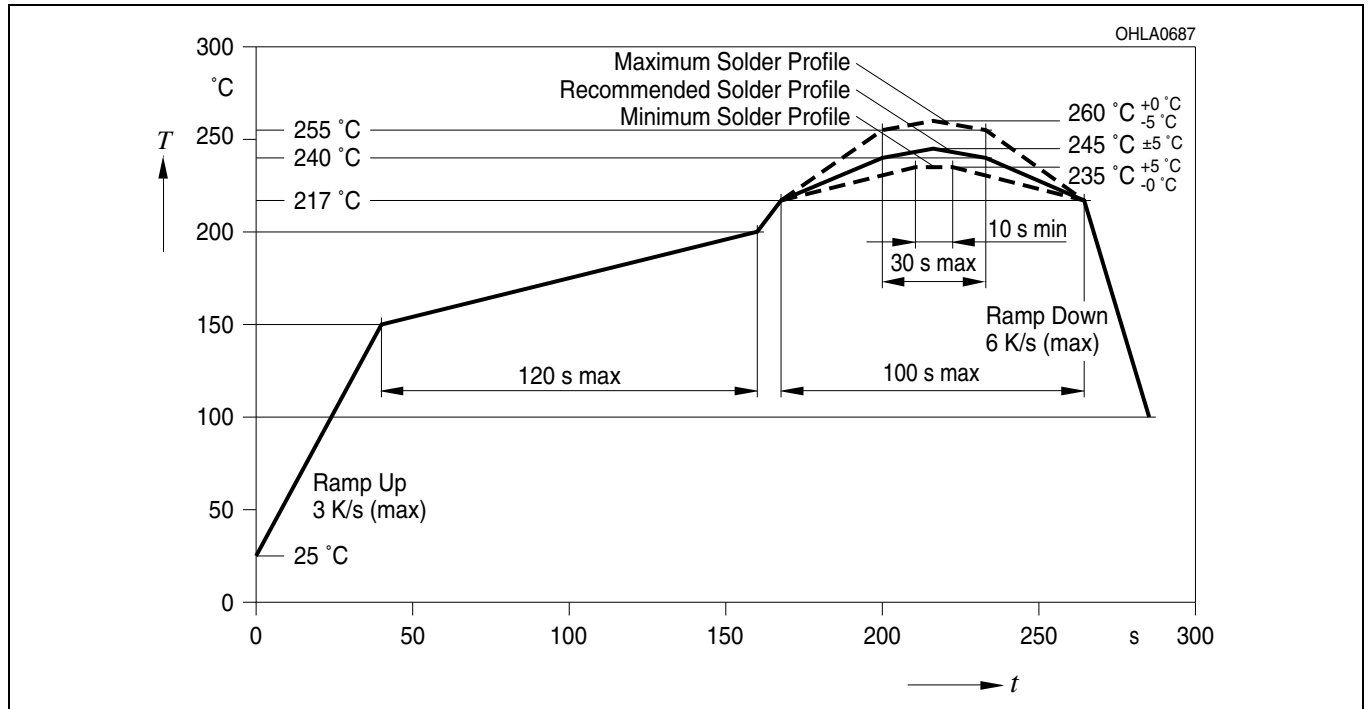
**Published by****OSRAM Opto Semiconductors GmbH**

Wernerwerkstrasse 2, D-93049 Regensburg

[www.osram-os.com](http://www.osram-os.com)**© All Rights Reserved.**

The information describes the type of component and shall not be considered as assured characteristics.

Terms of delivery and rights to change design reserved. Due to technical requirements components may contain dangerous substances. For information on the types in question please contact our Sales Organization.

**Packing**

Please use the recycling operators known to you. We can also help you – get in touch with your nearest sales office. By agreement we will take packing material back, if it is sorted. You must bear the costs of transport. For packing material that is returned to us unsorted or which we are not obliged to accept, we shall have to invoice you for any costs incurred.

**Components used in life-support devices or systems must be expressly authorized for such purpose!** Critical components<sup>1</sup>, may only be used in life-support devices or systems<sup>2</sup> with the express written approval of OSRAM OS.

<sup>1</sup> A critical component is a component used in a life-support device or system whose failure can reasonably be expected to cause the failure of that life-support device or system, or to affect its safety or effectiveness of that device or system.

<sup>2</sup> Life support devices or systems are intended (a) to be implanted in the human body, or (b) to support and/or maintain and sustain human life. If they fail, it is reasonable to assume that the health of the user may be endangered.