

# FSA1256(A) / FSA1257(A) / FSA1258(A)

## Low- $R_{ON}$ Low-Voltage, Dual SPST Analog Switch with Low- $I_{CCT}$ “A” Option

### Features

- FSA1256A, FSA1257A, FSA1258A Feature Low  $I_{CCT}$  when S Input is Lower than  $V_{CC}$
- Maximum 1.1  $\Omega$  On Resistance ( $R_{ON}$ ) for 4.5 V Supply
- 0.4  $\Omega$  Max.  $R_{ON}$  Flatness for 4.5 V Supply
- Space-Saving Pb-Free MicroPak™ Packaging
- Broad  $V_{CC}$  Operating Range:
  - FSA1256, FSA1257, FSA1258: 1.65 V to 5.5 V
  - FSA1256A, FSA1257A, FSA1258A: 2.7 V to 5.5 V
- Fast Turn-On and Turn-Off Times
- FSA1258, FSA1258A Feature Break-Before-Make Enable Circuitry
- Over-Voltage Tolerant TTL-Compatible Control Input

### Applications

- Cell Phone, PDA, Digital Camera, and Notebook
- LCD Monitor, TV, and Set-Top Box

### Description

The FSA1256, FSA1256A, FSA1257, FSA1257A, FSA1258, and FSA1258A are high performance dual Single-Pole / Single-Throw (SPST) analog switches. All devices feature ultra-low  $R_{ON}$  of 1.1  $\Omega$  maximum at 4.5 V  $V_{CC}$ . The FSA1256, FSA1257, and FSA1258 operate over a wide  $V_{CC}$  range of 1.65 V to 5.5 V. The FSA1256A, FSA1257A, and FSA1258A operation range is 2.7 V to 5.5 V. These devices are fabricated with sub-micron CMOS technology to achieve fast switching speeds and are designed for break-before-make operation. The select input is TTL level compatible. The FSA1256 and FSA1256A feature two Normally Open (NO) switches. The FSA1257 and FSA1257A feature two Normally Closed (NC) switches. The FSA1258 and FSA1258A have one NO switch and one NC switch.

### IMPORTANT NOTE:

For additional performance information, please contact [analogswitch@fairchildsemi.com](mailto:analogswitch@fairchildsemi.com).

### Ordering Information

Part Number	Top Mark	Package Description	Packing Method
FSA1256L8X	EB	8-Lead, MicroPak™, 1.6 mm Wide	5000 Units Tape and Reel
FSA1256AL8X	FN	8-Lead, MicroPak, 1.6 mm Wide	5000 Units Tape and Reel
FSA1257L8X	EC	8-Lead, MicroPak, 1.6 mm Wide	5000 Units Tape and Reel
FSA1257AL8X	FP	8-Lead, MicroPak, 1.6 mm Wide	5000 Units Tape and Reel
FSA1258L8X	ED	8-Lead, MicroPak, 1.6 mm Wide	5000 Units Tape and Reel
FSA1258AL8X	FS	8-Lead, MicroPak, 1.6 mm Wide	5000 Units Tape and Reel

MicroPak™ is a trademark of Fairchild Semiconductor Corporation.

### Analog Symbols

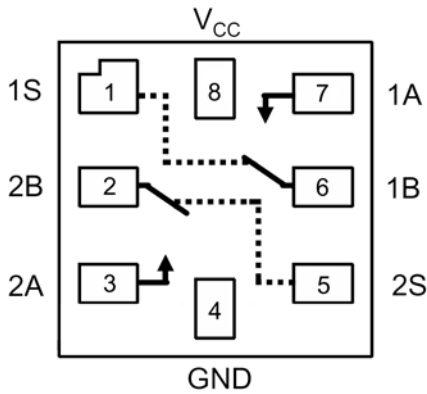


Figure 1. FSA1256, FSA1256A

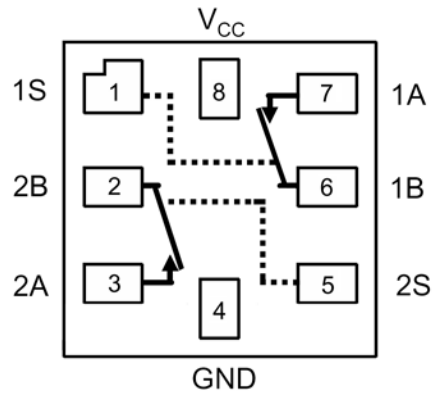


Figure 2. FSA1257, FSA1257A

### Truth Tables

Control Input (s)	Function
LOW Logic Level	Disconnect
HIGH Logic Level	A Connected to B

Control Input (s)	Function
LOW Logic Level	A Connected to B
HIGH Logic Level	Disconnected

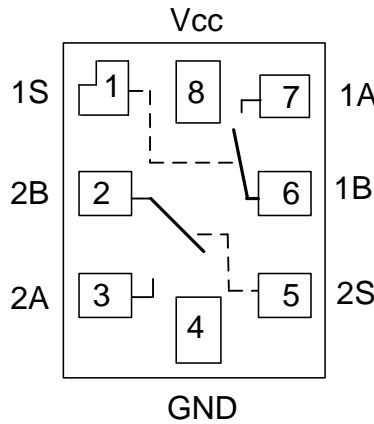


Figure 3. FSA1258, FSA1258A

### Truth Table

Control Input, 1S	Function	Control Input 2S	Function
LOW Logic Level	1A Connected to 1B	LOW Logic Level	Disconnect
HIGH Logic Level	Disconnect	HIGH Logic Level	2A Connected to 2B

### Pin Descriptions

Name	Description
A, B <sub>0</sub> , B <sub>1</sub>	Data Ports
S	Switch Select Pin

## Absolute Maximum Ratings

Stresses exceeding the absolute maximum ratings may damage the device. The device may not function or be operable above the recommended operating conditions and stressing the parts to these levels is not recommended. In addition, extended exposure to stresses above the recommended operating conditions may affect device reliability. The absolute maximum ratings are stress ratings only.

Symbol	Parameter	Min.	Max.	Units
V <sub>CC</sub>	Supply Voltage	-0.5	6.0	V
V <sub>S</sub>	Switch Voltage <sup>(1)</sup>	-0.5	V <sub>CC</sub> +0.5	V
V <sub>in</sub>	Input Voltage <sup>(1)</sup>	-0.5	6.0	V
	Power Dissipation at 85°C, MicroPak 8-Lead Package		180	mW
I <sub>IK</sub>	Input Diode Current		-50	mA
I <sub>SW</sub>	Switch Current		200	mA
I <sub>SWPEAK</sub>	Peak Switch Current (Pulsed at 1ms Duration, <10% Duty Cycle)		400	mA
T <sub>STG</sub>	Storage Temperature Range	-65	+150	°C
T <sub>J</sub>	Maximum Junction Temperature		+150	°C
T <sub>L</sub>	Lead Temperature (Soldering 10 Seconds)		+260	°C
ESD	Human Body Model (JEDEC: JESD22-A114)	FSA1256, FSA1257, FSA1258	5.5	kV
		FSA1256A, FSA1257A, FSA1258A	4.5	

**Note:**

1. Input and output negative ratings may be exceeded if input and output diode current ratings are observed.

## Recommended Operating Conditions

The Recommended Operating Conditions table defines the conditions for actual device operation. Recommended operating conditions are specified to ensure optimal performance to the datasheet specifications. Fairchild does not recommend exceeding them or designing to absolute maximum ratings.

Symbol	Parameter	Min.	Max.	Units	
V <sub>CC</sub>	Supply Voltage	FSA1256, FSA1257, FSA1258	1.65	5.50	V
		FSA1256A, FSA1257A, FSA1258A	2.70	5.50	
V <sub>IN</sub>	Control Input Voltage <sup>(2)</sup>	0	V <sub>CC</sub>	V	
V <sub>IN</sub>	Switch Input Voltage	0	V <sub>CC</sub>	V	
Θ <sub>JA</sub>	Thermal Resistance in Still Air, MicroPak 8L Package (Modeled)		224	°C/W	
T <sub>A</sub>	Operating Temperature	-40	+85	°C	

**Note:**

2. Unused inputs must be held HIGH or LOW. They must not float.

## DC Electrical Characteristics

All typical values are at 25°C unless otherwise specified. The 1.65 V to 1.95 V range applies to FSA1256, FSA1257, and FSA1258 only.

Symbol	Parameter	Conditions	V <sub>CC</sub> (V)	T <sub>A</sub> =+25°C			T <sub>A</sub> =-40 to +85°C		Unit
				Min.	Typ.	Max.	Min.	Max.	
V <sub>IH</sub>	Input Voltage High <sup>(3)</sup>		4.5 to 5.5				2.4		V
			2.7 to 3.6				2.0		
			1.65 to 1.95				0.9		
V <sub>IL</sub>	Input Voltage Low <sup>(3)</sup>	FSA1256A, FSA1257A, FSA1258A Only	4.5 to 5.5					0.8	V
			2.7 to 3.6					0.4	
			2.7 to 3.6					0.6	
			1.65 to 1.95					0.4	
I <sub>IN</sub>	Control Input Leakage (S)	V <sub>IN</sub> =0 to V <sub>CC</sub>	1.95 to 5.5				-1	1	μA
I <sub>NO(OFF)</sub> , I <sub>NC(OFF)</sub>	Off Leakage Current	A=1 V, 4.5 V 1B or 2B=1 V, 4.5 V	5.5		±2		-20	20	nA
R <sub>ON</sub>	Switch On Resistance <sup>(3,4)</sup>	I <sub>OUT</sub> =100 mA, 1B or 2B=3.5 V	4.5		0.95	1.15		1.30	Ω
		I <sub>OUT</sub> =100 mA, 1B or 2B=1.5 V	2.7		2.6	4.0		4.3	
		I <sub>OUT</sub> =100 mA, 1B or 2B=1.2 V	1.65		8.0	9.5		10.5	
ΔR <sub>ON</sub>	On Resistance Matching Between Channels <sup>(3,5)</sup>	I <sub>OUT</sub> =100 mA, 1B or 2B=3.5 V	4.5		0.06	0.12		0.15	Ω
R <sub>FLAT(ON)</sub>	On Resistance Flatness <sup>(3,6)</sup>	I <sub>OUT</sub> =100 mA, 1B or 2B=0 V, 1.0 V, 2.0 V	4.5		0.2	0.3		0.4	Ω
		I <sub>OUT</sub> =100 mA, 1B or 2B=0 V, 0.75 V, 1.5 V	2.7		1.4				
		I <sub>OUT</sub> =100 mA, 1B or 2B=0 V, 1.0 V, 1.2 V	1.65		1.8				
I <sub>CC</sub>	Quiescent Supply Current	V <sub>IN</sub> =0 V or V <sub>CC</sub> , I <sub>OUT</sub> =0 V	5.5		0.1	0.5		1.0	μA
			3.6		0.1	0.5		1.0	
I <sub>CC</sub> T	Increase in I <sub>CC</sub> per Input	One Input at 2.6 V, Others at V <sub>CC</sub> or GND (FSA1256A, FSA1257A, FSA1258A Only)	4.3		0.2			10.0	μA

### Notes:

- Guaranteed, but not tested for V<sub>CC</sub>=1.65 V.
- On resistance is determined by the voltage drop between A and B pins at the indicated current through the switch.
- Δ R<sub>ON</sub>=R<sub>ON max</sub> – R<sub>ON min</sub> measured at identical V<sub>CC</sub>, temperature, and voltage.
- Flatness is defined as the difference between the maximum and minimum value of on resistance (R<sub>ON</sub>) over the specified range of conditions.

## AC Electrical Characteristics

All typical values are at 25°C unless otherwise specified. The 1.65 V to 1.95 V range applies to FSA1256, FSA1257, and FSA1258 only.

Symbol	Parameter	Conditions	V <sub>CC</sub> (V)	T <sub>A</sub> =+25°C			T <sub>A</sub> =-40 to +85°C		Unit	Figure
				Min.	Typ.	Max.	Min.	Max.		
t <sub>ON</sub>	Turn-On Time <sup>(7)</sup>	1B or 2B=3.0 V, R <sub>L</sub> =50 Ω, C <sub>L</sub> =35 pF	4.5 to 5.5		10	35		40	ns	Figure 8
		1B or 2B=1.5 V, R <sub>L</sub> =50 Ω, C <sub>L</sub> =35 pF	2.7 to 3.6		15	50		60		
		1B or 2B=1.0 V R <sub>L</sub> =50 Ω, C <sub>L</sub> =35 pF	1.65 to 1.95		35	110		120		
t <sub>OFF</sub>	Turn-Off Time <sup>(7)</sup>	1B or 2B=3.0 V, R <sub>L</sub> =50 Ω, C <sub>L</sub> =35 pF	4.5 to 5.5		4	15		20	ns	Figure 8
		1B or 2B=1.5 V, R <sub>L</sub> =50 Ω, C <sub>L</sub> =35 pF	2.7 to 3.6		8	20		30		
		1B or 2B=1.0 V R <sub>L</sub> =50 Ω, C <sub>L</sub> =35 pF	1.65 to 1.95		10	30		40		
t <sub>BBM</sub>	Break-Before-Make Time <sup>(7)</sup>	1B or 2B=3.0 V, R <sub>L</sub> =50 Ω, C <sub>L</sub> =35 pF	4.5 to 5.5		7				ns	Figure 9
		1B or 2B=1.5 V, R <sub>L</sub> =50 Ω, C <sub>L</sub> =35 pF	2.7 to 3.6		12					
Q	Charge Injection <sup>(7)</sup>	C <sub>L</sub> =1.0 nF, V <sub>GEN</sub> =0 V, R <sub>GEN</sub> =0 Ω	4.5 to 5.5		20				pC	Figure 13
			2.7 to 3.6		10					
			1.65 to 1.95		5					
OIRR	Off Isolation <sup>(7)</sup>	f=1 MHz, R <sub>L</sub> =50 Ω,	1.65 to 5.50		-70				dB	Figure 11
Xtalk	Crosstalk <sup>(7)</sup>	f=1 MHz, R <sub>L</sub> =50 Ω,	1.65 to 4.30		-100				dB	Figure 12
BW	-3db Bandwidth <sup>(7)</sup>	R <sub>L</sub> =50 Ω	1.65 to 4.30		300				MHz	Figure 10
THD	Total Harmonic Distortion <sup>(7)</sup>	f=20 Hz to 20 kHz, R <sub>L</sub> =600 Ω, V <sub>IN</sub> =0.5 V <sub>PP</sub>	1.65 to 4.30		0.002				%	Figure 16

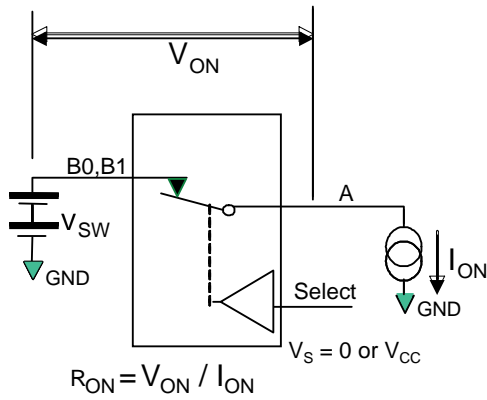
### Notes:

7. Guaranteed, but not tested for V<sub>CC</sub>=1.65 V.

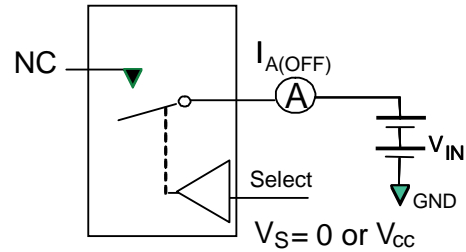
## Capacitance

Symbol	Parameter	Conditions	V <sub>CC</sub> (V)	T <sub>A</sub> =+25°C			Unit	Figure
				Min.	Typ.	Max.		
C <sub>IN</sub>	Control Pin Input Capacitance	f=1 MHz	0		3.0		pF	Figure 15
C <sub>OFF</sub>	B Port Off Capacitance	f=1 MHz	4.5		11.5		pF	Figure 14
C <sub>ON</sub>	A Port On Capacitance	f=1 MHz	4.5		27.0		pF	Figure 15

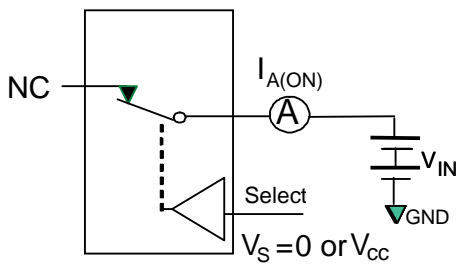
### Test Diagrams



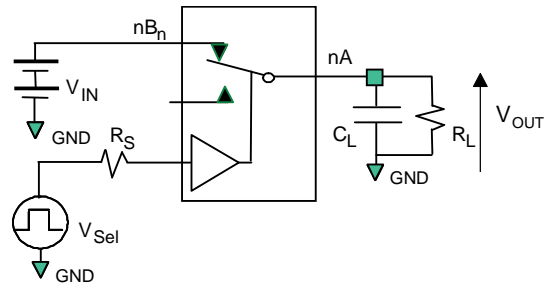
**Figure 4. On Resistance**



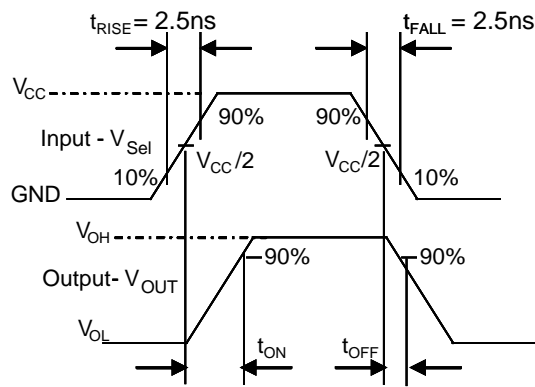
**Figure 5. Off Leakage (Ports Tested Separately)**



**Figure 6. On Leakage**

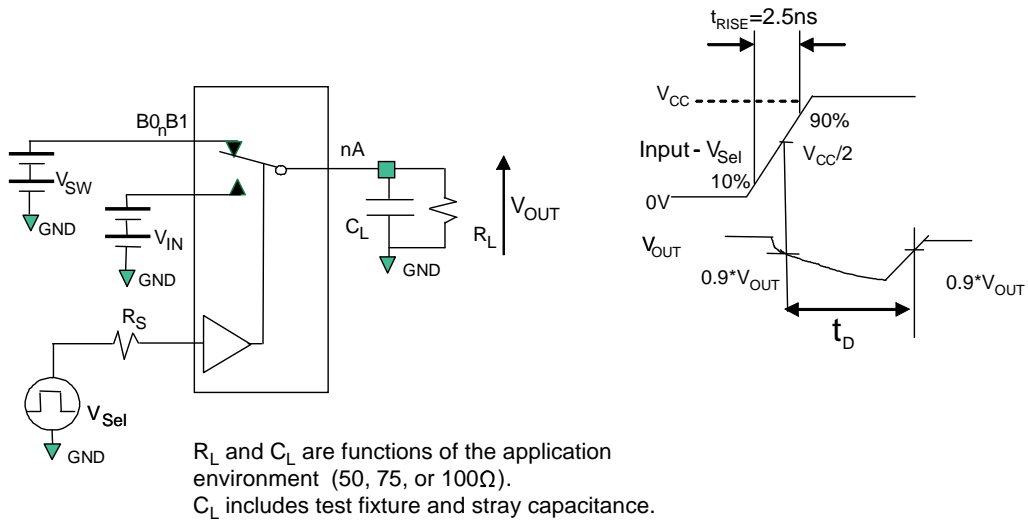


**Figure 7. Test Circuit Load**

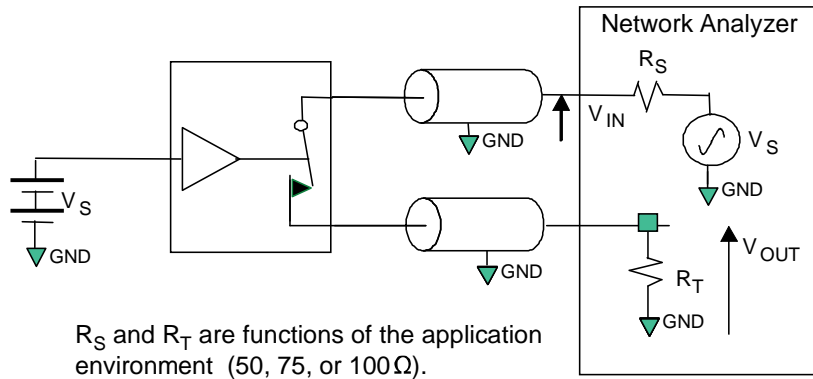


**Figure 8. Turn-On / Turn-Off Waveforms**

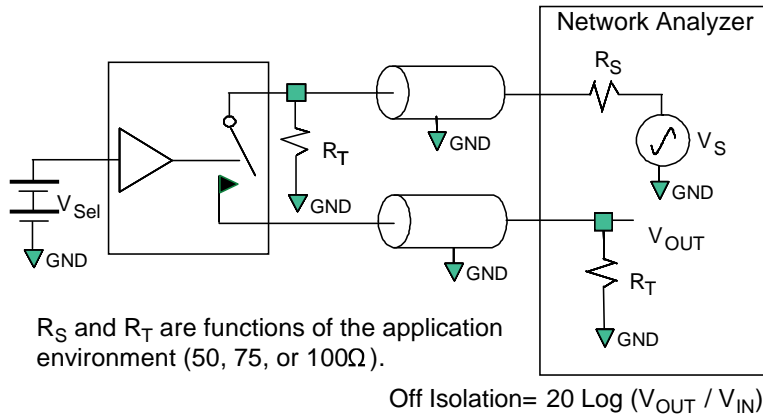
**Test Diagrams** (Continued)



**Figure 9. Break-Before-Make Interval Timing**

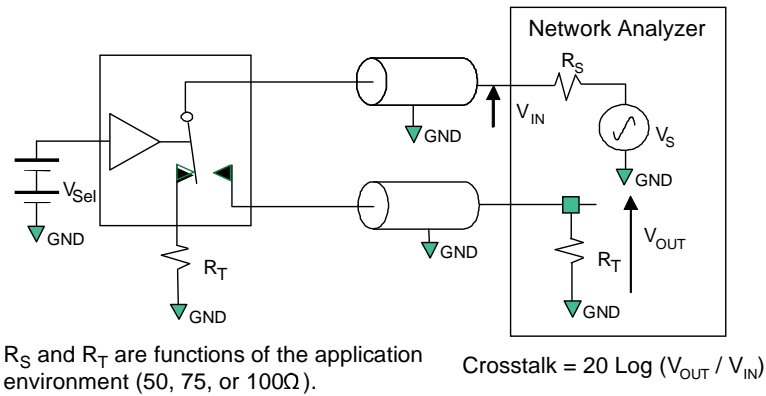


**Figure 10. Bandwidth**

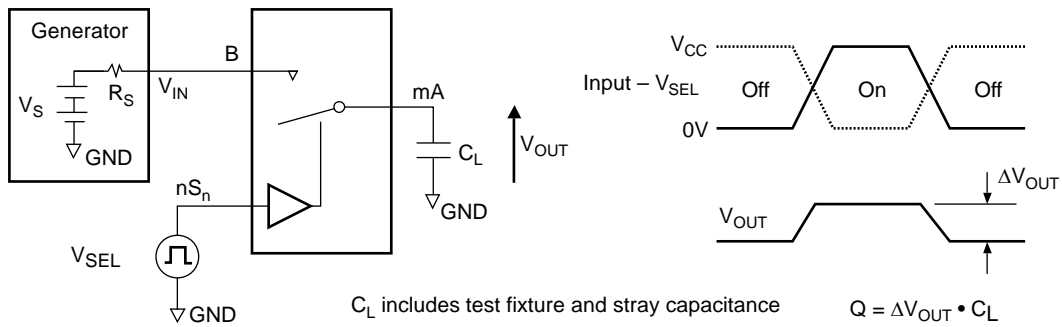


**Figure 11. Channel Off Isolation**

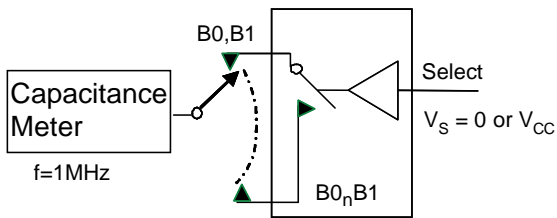
**Test Diagrams (Continued)**



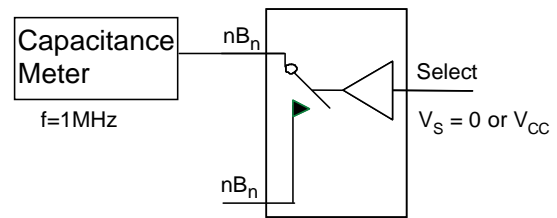
**Figure 12. Adjacent Channel Crosstalk**



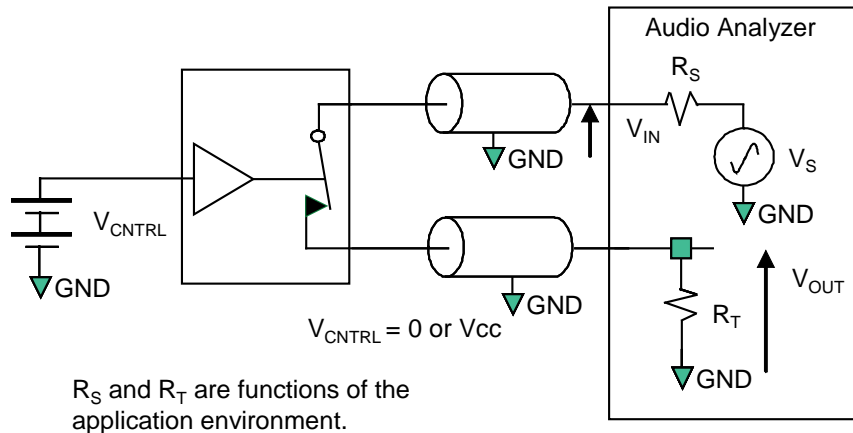
**Figure 13. Charge Injection Test**



**Figure 14. Channel Off Capacitance**

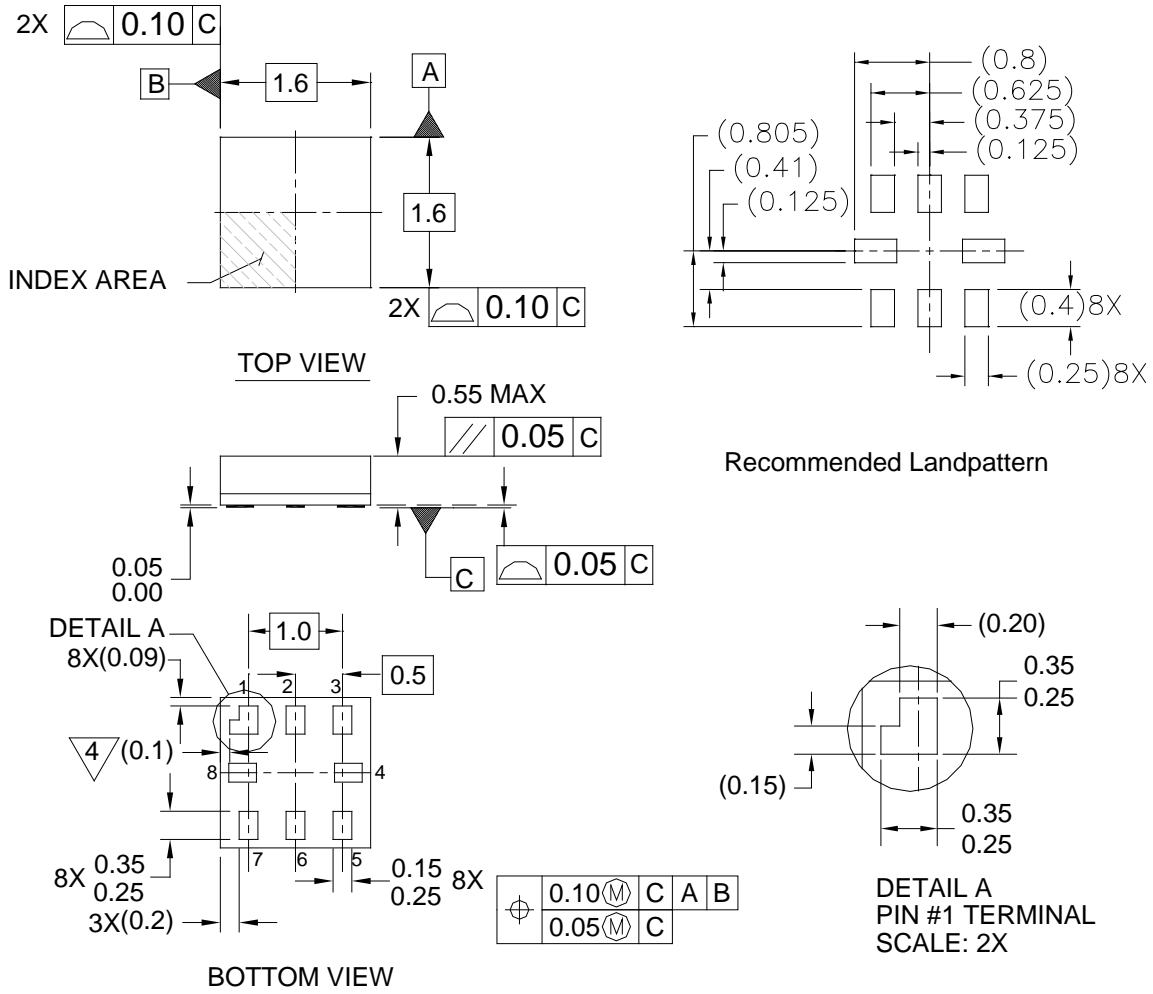


**Figure 15. Channel On Capacitance**



**Figure 16. Total Harmonic Distortion**

## Physical Dimensions



### Notes:

1. PACKAGE CONFORMS TO JEDEC MO-255 VARIATION UAAD
2. DIMENSIONS ARE IN MILLIMETERS
3. DRAWING CONFORMS TO ASME Y.14M-1994
4. PIN 1 FLAG, END OF PACKAGE OFFSET
5. DRAWING FILE NAME: MKT-MAC08AREV4

MAC08AREV4

**Figure 17. 8-Lead MicroPak™, 1.6 mm Wide**

For tape and reel specifications for MicroPak, please visit:  
[http://www.fairchildsemi.com/products/logic/pdf/micropak\\_tr.pdf](http://www.fairchildsemi.com/products/logic/pdf/micropak_tr.pdf)





Package drawings are provided as a service to customers considering Fairchild components. Drawings may change in any manner without notice. Please note the revision and/or date on the drawing and contact a Fairchild Semiconductor representative to verify or obtain the most recent revision. Package specifications do not expand the terms of Fairchild's worldwide terms and conditions, specifically the warranty therein, which covers Fairchild products.

Always visit Fairchild Semiconductor's online packaging area for the most recent package drawings:  
<http://www.fairchildsemi.com/packaging/>



**TRADEMARKS**

The following includes registered and unregistered trademarks and service marks, owned by Fairchild Semiconductor and/or its global subsidiaries, and is not intended to be an exhaustive list of all such trademarks.

- |   |  |   |   |
|---|--|---|---|
| AccuPower™  | F-PFST™  |  | Sync-Lock™  |
| AX-CAP®   | FRFET®   | PowerXST™   |  |
| BitSiC™   | Global Power Resource™                         | Programmable Active Droop™  | TinyBoost®  |
| Build it Now™   | GreenBridge™                                   | QFET®   | TinyBuck®   |
| CorePLUS™   | Green FPST™                                    | QST™  | TinyCalc™   |
| CorePOWER™  | Green FPST™ e-Series™                          | Quiet Series™   | TinyLogic®  |
| CROSSVOLT™  | Gmax™  | RapidConfigure™   | TINYOPTO™   |
| CTL™  | GTO™   |  | TinyPower™  |
| Current Transfer Logic™   | IntelliMAX™                                    | Saving our world, 1mW/W/KW at a time™   | TinyPWM™  |
| DEUXPEED®   | ISOPLANAR™                                     | SignalWise™   | TinyWire™   |
| Dual Cool™  | Making Small Speakers Sound Louder and Better™ | SmartMax™   | TranSiC™  |
| EcoSPARK®   | MegaBuck™                                      | SMART START™  | TriFault Detect™  |
| EfficientMax™   | MICROCOUPLER™                                  | Solutions for Your Success™   | TRUECURRENT®  |
| ESBCT™  | MicroFET™                                      | SPM®  | µSerDes™  |
|  | MicroPak™                                      | STEALTH™  |  |
| Fairchild®  | MicroPak2™                                     | SuperFET®   | UHC™  |
| Fairchild Semiconductor®  | MillerDrive™                                   | SuperSOT™-3   | Ultra FRFET™  |
| FACT Quiet Series™  | MotionMax™                                     | SuperSOT™-6   | UniFET™   |
| FACT®   | miWSaver®                                      | SuperSOT™-8   | VCX™  |
| FAST®   | OptoHIT™                                       | SupreMOS®   | VisualMax™  |
| FastvCore™  | OPTOLOGIC®                                     | SyncFET™  | VoltagePlus™  |
| FETBench™   | OPTOPLANAR®                                    |   | XST™  |
| FPST™   |  |   |   |

\* Trademarks of System General Corporation, used under license by Fairchild Semiconductor.

**DISCLAIMER**

FAIRCHILD SEMICONDUCTOR RESERVES THE RIGHT TO MAKE CHANGES WITHOUT FURTHER NOTICE TO ANY PRODUCTS HEREIN TO IMPROVE RELIABILITY, FUNCTION, OR DESIGN. FAIRCHILD DOES NOT ASSUME ANY LIABILITY ARISING OUT OF THE APPLICATION OR USE OF ANY PRODUCT OR CIRCUIT DESCRIBED HEREIN; NEITHER DOES IT CONVEY ANY LICENSE UNDER ITS PATENT RIGHTS, NOR THE RIGHTS OF OTHERS. THESE SPECIFICATIONS DO NOT EXPAND THE TERMS OF FAIRCHILD'S WORLDWIDE TERMS AND CONDITIONS, SPECIFICALLY THE WARRANTY THEREIN, WHICH COVERS THESE PRODUCTS.

**LIFE SUPPORT POLICY**

FAIRCHILD'S PRODUCTS ARE NOT AUTHORIZED FOR USE AS CRITICAL COMPONENTS IN LIFE SUPPORT DEVICES OR SYSTEMS WITHOUT THE EXPRESS WRITTEN APPROVAL OF FAIRCHILD SEMICONDUCTOR CORPORATION.

As used herein:

1. Life support devices or systems are devices or systems which, (a) are intended for surgical implant into the body or (b) support or sustain life, and (c) whose failure to perform when properly used in accordance with instructions for use provided in the labeling, can be reasonably expected to result in a significant injury of the user.
2. A critical component in any component of a life support, device, or system whose failure to perform can be reasonably expected to cause the failure of the life support device or system, or to affect its safety or effectiveness.

**ANTI-COUNTERFEITING POLICY**

Fairchild Semiconductor Corporation's Anti-Counterfeiting Policy. Fairchild's Anti-Counterfeiting Policy is also stated on our external website, [www.fairchildsemi.com](http://www.fairchildsemi.com), under Sales Support.

Counterfeiting of semiconductor parts is a growing problem in the industry. All manufacturers of semiconductor products are experiencing counterfeiting of their parts. Customers who inadvertently purchase counterfeit parts experience many problems such as loss of brand reputation, substandard performance, failed applications, and increased cost of production and manufacturing delays. Fairchild is taking strong measures to protect ourselves and our customers from the proliferation of counterfeit parts. Fairchild strongly encourages customers to purchase Fairchild parts either directly from Fairchild or from Authorized Fairchild Distributors who are listed by country on our web page cited above. Products customers buy either from Fairchild directly or from Authorized Fairchild Distributors are genuine parts, have full traceability, meet Fairchild's quality standards for handling and storage and provide access to Fairchild's full range of up-to-date technical and product information. Fairchild and our Authorized Distributors will stand behind all warranties and will appropriately address any warranty issues that may arise. Fairchild will not provide any warranty coverage or other assistance for parts bought from Unauthorized Sources. Fairchild is committed to combat this global problem and encourage our customers to do their part in stopping this practice by buying direct or from authorized distributors.

**PRODUCT STATUS DEFINITIONS**

**Definition of Terms**

Datasheet Identification	Product Status	Definition
Advance Information	Formative / In Design	Datasheet contains the design specifications for product development. Specifications may change in any manner without notice.
Preliminary	First Production	Datasheet contains preliminary data; supplementary data will be published at a later date. Fairchild Semiconductor reserves the right to make changes at any time without notice to improve design.
No Identification Needed	Full Production	Datasheet contains final specifications. Fairchild Semiconductor reserves the right to make changes at any time without notice to improve the design.
Obsolete	Not In Production	Datasheet contains specifications on a product that is discontinued by Fairchild Semiconductor. The datasheet is for reference information only.

Rev. 166