



Single Output A-Series, UWR Models

High-Density, 2" x 1" 15 Watt, DC/DC Converters

A - SERIES

Features

- Synchronous rectifier topology
- Guaranteed efficiencies to 86%
- Standard 2" x 1" package and pinout
- Compatible with Lucent LC/LW Series
- -40 to +60°C ambient operation without derating
- 3.3, 5, 12 or 15 Volt outputs
- Choice of 3 input voltage ranges:
10-18V, 18-36V, 36-75V
- Fully isolated, 1500Vdc guaranteed
- UL1950/EN60950 approvals pending
- mark available (75V-input models)
- Optional V_{out} trim and on/off control
- Fully I/O protected

The newest products in DATEL's flagship A-Series are the single-output UWR 15 Watt models. These power converters exemplify DATEL's relentless drive to bring you more power, in standard packages, without compromising reliability or resorting to thermal specmanship.

The combination of a high-frequency (300kHz), high-efficiency, synchronous-rectifier topology with the newest components and time-tested, fully automated, SMT-on-pcb construction, enables these UWR Models to bring you 15 Watts in the standard 2" x 1" package from which most competitors can only deliver 5-10 Watts. And the UWR's deliver their full output power over ambient temperature ranges from -40°C to as high as +70°C (model and input voltage dependent) without heat sinks or forced-air cooling. Devices derate to +100°C.

Output voltages are 3.3, 5, 12 or 15 Volts. Input voltage ranges are 10-18V ("D12A" models), 18-36V ("D24A" models) or 36-75V ("D48A" models). All models feature input pi filters, input undervoltage and overvoltage lockout, input reverse-polarity protection, output overvoltage protection, output current limiting, and short-circuit protection. On/off control, sync, and output-trim functions are optional (see Optional Functions). These devices satisfy IEC950, UL1950 and EN60950 safety requirements for OPERATIONAL insulation. CE marking is available for "D48A" models (36-75V inputs).

UWR 15W DC/DC's are packaged in low-cost, light-weight, diallyl phthalate (UL94V-0 rated), plastic packages with standoffs. EMC compliance is achieved via a low-noise design rather than through expensive metal shielding.

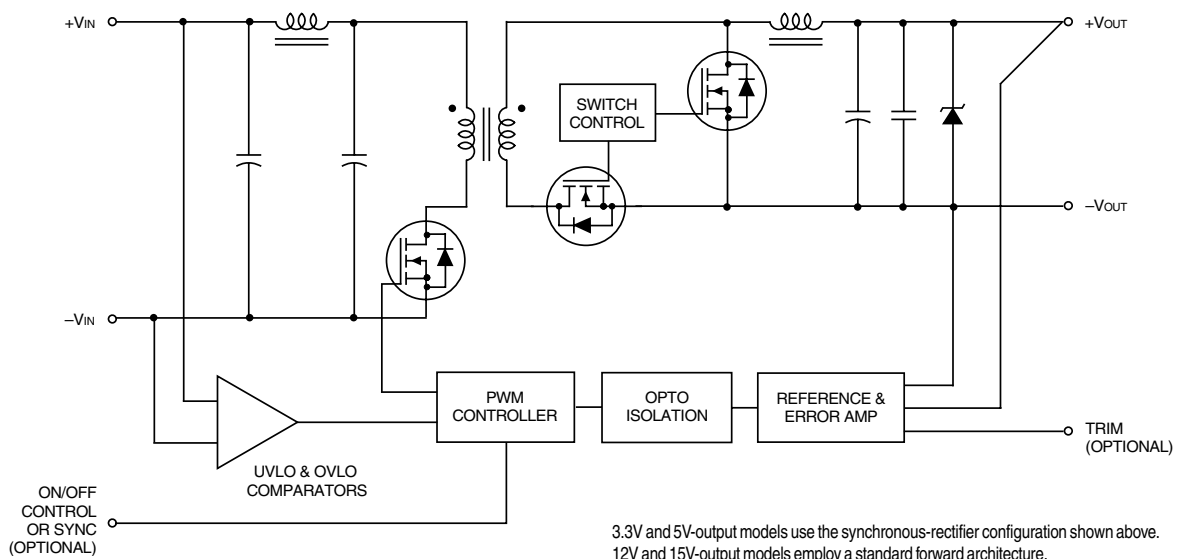

Figure 1. Simplified Schematic

Performance Specifications and Ordering Guide ^①

Model	Output						Input			Efficiency		Package (Case, Pinout)
	V _{OUT} (Volts)	I _{OUT} (mA)	R/N (mVp-p) ^②		Regulation (Max.)		V _{IN} Nom. (Volts)	Range (Volts)	I _{IN} ^④ (mA)	Min.	Typ.	
			Typ.	Max.	Line	Load ^③						
UWR-3.3/4250-D12A	3.3	4250	85	100	±0.2%	±0.5%	12	10-18	80/1375	83%	85%	C14, P22
UWR-3.3/4250-D24A	3.3	4250	85	100	±0.2%	±0.5%	24	18-36	45/672	84.5%	87%	C14, P22
UWR-3.3/4250-D48A	3.3	4250	85	100	±0.2%	±0.5%	48	36-75	35/336	85%	87%	C14, P22
UWR-5/3000-D12A	5	3000	85	100	±0.2%	±0.3%	12	10-18	110/1471	83%	85%	C14, P22
UWR-5/3000-D24A	5	3000	85	100	±0.2%	±0.3%	24	18-36	55/710	85.5%	88%	C14, P22
UWR-5/3000-D48A	5	3000	85	100	±0.2%	±0.3%	48	36-75	35/355	85.5%	88%	C14, P22
UWR-12/1250-D12A	12	1250	85	100	±0.2%	±0.3%	12	10-18	20/1471	82.5%	85%	C14, P22
UWR-12/1250-D24A	12	1250	85	100	±0.2%	±0.3%	24	18-36	20/718	85%	87%	C14, P22
UWR-12/1250-D48A	12	1250	85	100	±0.2%	±0.3%	48	36-75	20/359	85%	87%	C14, P22
UWR-15/1000-D12A	15	1000	85	100	±0.2%	±0.3%	12	10-18	20/1471	82.5%	85%	C14, P22
UWR-15/1000-D24A	15	1000	85	100	±0.2%	±0.3%	24	18-36	20/718	85%	87%	C14, P22
UWR-15/1000-D48A	15	1000	85	100	±0.2%	±0.3%	48	36-75	20/359	85%	87%	C14, P22

- ① Typical at T_A = +25°C under nominal line voltage and full-load conditions, unless otherwise noted.
- ② Ripple/Noise (R/N) measured over a 20MHz bandwidth. All models are specified with two external 0.47µF multi-layer ceramic capacitors installed across their output pins.
- ③ 10% to 100% load.
- ④ Nominal line voltage, no-load/full-load conditions.

PART NUMBER STRUCTURE

UWR-5/3000-D48ACT

Output Configuration:
U = Unipolar

Wide Range Input

Nominal Output Voltage:
3.3, 5, 12 or 15 Volts

Maximum Output Current
in mA

Optional Functions
See Below

A-Series
High Reliability

Input Voltage Range:
D12 = 10-18 Volts (12V nominal)
D24 = 18-36 Volts (24V nominal)
D48 = 36-75 Volts (48V nominal)

Optional Functions

A-Series UWR 15 Watt DC/DC Converters have been designed so that an On/Off Control function, with either positive (add "C" suffix to part number) or negative ("N" suffix) polarity, or a Sync function ("S" suffix) can be added in the pin 3 position. Additionally, an output-voltage Trim function ("T" suffix) can be added to the pin 5 position. There are 7 possible combinations of one or two-character, part-number suffixes as described below:

- T Trim function on pin 5. No pin 3.
- C On/Off Control function (positive polarity) on pin 3. No pin 5.
- CT On/Off Control function (positive polarity) on pin 3. Trim function on pin 5.
- N On/Off Control function (negative polarity) on pin 3. No pin 5.
- NT On/Off Control function (negative polarity) on pin 3. Trim function on pin 5.
- S Sync function on pin 3. No pin 5.
- ST Sync function on pin 3. Trim function on pin 5.
- Blank -- No Trim function. No On/Off Control function.

MECHANICAL SPECIFICATIONS

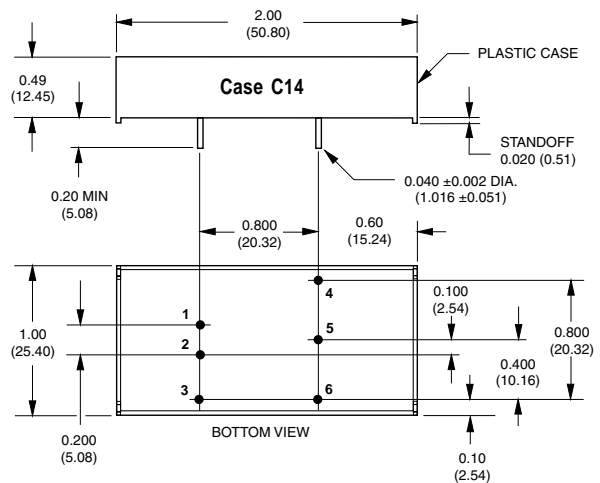

I/O Connections	
Pin	Function P22
1	+Input
2	-Input
3	On/Off Control*
4	+Output
5	Trim*
6	Common

* Pins 3 and 5 are optional. See Optional Functions and Technical Notes for details.

Performance/Functional Specifications

Typical @ T_A = +25°C under nominal line voltage and full-load conditions, unless noted. ①②

Input	
Input Voltage Range:	
"D12" Models	10-18 Volts (12V nominal)
"D24" Models	18-36 Volts (24V nominal)
"D48" Models	36-75 Volts (48V nominal)
Overvoltage Shutdown:	
"D12" Models	20 Volts
"D24" Models	40 Volts
"D48" Models	80 Volts
Start-Up Threshold: ③	
"D12" Models	8 Volts
"D24" Models	17 Volts
"D48" Models	35 Volts
Undervoltage Shutdown: ③	
"D12" Models	7 Volts
"D24" Models	16 Volts
"D48" Models	34 Volts
Input Current:	
Normal Operating Conditions	See Ordering Guide
Standby Mode (Off, OV, UV)	5mA
Input Filter Type	Pi
Reverse-Polarity Protection:	
"D12" Models	Brief duration, 10A maximum
"D24" Models	Brief duration, 10A maximum
"D48" Models	Brief duration, 10A maximum
On/Off Control (Pin 3) ④	TTL high (or open) = on, low = off
Output	
V_{out} Accuracy (50% load):	
3.3V Outputs	±1.5%, maximum
5/12/15V Outputs	±1%, maximum
Temperature Coefficient	±0.04% per °C
Ripple/Noise (20MHz BW) ② ⑤	See Ordering Guide
Line/Load Regulation	See Ordering Guide
Efficiency	See Ordering Guide
Isolation Voltage:	
Input-to-Output	1500Vdc, minimum
Input-to-Case	1500Vdc, minimum
Output-to-Case	1500Vdc, minimum
Isolation Capacitance	600pF
Isolation Resistance	100MΩ
Current Limiting:	
3.3V and 5V Outputs	Hiccup technique, auto-recovery
12V and 15V Outputs	Power-limiting technique, auto-recovery
Overvoltage Protection	Zener/transorb clamp, magnetic feedback
Dynamic Characteristics	
Transient Response (50% load step)	200µsec max. to ±1.5% of final value
Start-Up Time: ③	
V _{IN} to V _{OUT}	50msec
On/Off to V _{OUT}	30msec
Switching Frequency	300kHz (±15kHz)

Environmental	
Operating Temperature (Ambient):	
Without Derating	-40 to +60°C
With Derating	to +100°C (See Derating Curves)
Case Temperature:	
Maximum Allowable	+100°C
Storage Temperature	-40 to +105°C
Physical	
Dimensions	2" x 1" x 0.49" (51 x 25 x 12.45mm)
Shielding	None
Case Material	Diallyl phthalate, UL94V-0 rated
Pin Material	Brass, solder coated
Weight	1.4 ounces (39.7 grams)

- ① These power converters require a minimum 10% output loading to maintain specified regulation. Operation under no-load conditions will not damage these devices; however they may not meet all listed specifications.
- ② All models are specified with two external 0.47µF multi-layer ceramic capacitors installed across their output pins.
- ③ See Technical Notes for details.
- ④ The On/Off Control, Sync and Trim functions are optional and must be installed by DATEL. See Optional Functions or contact DATEL for details.
- ⑤ Output noise may be further reduced with the installation of additional external output capacitors. See Technical Notes.

Absolute Maximum Ratings	
Input Voltage:	
Continuous:	
"D12" Models	22 Volts
"D24" Models	44 Volts
"D48" Models	88 Volts
Transient (100msec):	
"D12" Models	50 Volts
"D24" Models	50 Volts
"D48" Models	100 Volts
Input Reverse-Polarity Protection	Current must be <10 Amps. Brief duration only. Fusing recommended.
Output Overvoltage Protection:	
3.3V Outputs	4.5 Volts, unlimited duration
5V Outputs	6.8 Volts, unlimited duration
12V Outputs	15 Volts, unlimited duration
15V Outputs	18 Volts, unlimited duration
Output Current	Current limited. Devices can withstand sustained output short circuits without damage.
Case Temperature	+100°C
Storage Temperature	-40 to +105°C
Lead Temperature (soldering, 10 sec.)	+300°C
These are stress ratings. Exposure of devices to any of these conditions may adversely affect long-term reliability. Proper operation under conditions other than those listed in the Performance/Functional Specifications Table is not implied.	

TECHNICAL NOTES

Floating Outputs

Since these are isolated DC/DC converters, their outputs are "floating." Designers will usually use the output Common (pin 6) as the ground/return of the load circuit. You can, however, use the +Output (pin 4) as ground/return to effectively reverse the output polarity.

Filtering and Noise Reduction

All A-Series UWR 15 Watt DC/DC Converters achieve their rated ripple and noise specifications using the external input and output capacitors specified in the Performance/Functional Specifications table. In critical applications, input/output noise may be further reduced by installing additional external I/O caps. Input capacitors should be selected for bulk capacitance, low ESR and high rms-ripple-current ratings. Output capacitors should be selected for low ESR and appropriate frequency response. All caps should have appropriate voltage ratings and be mounted as close to the converters as possible.

The most effective combination of external I/O capacitors will be a function of your particular load and layout conditions. Our Applications Engineers will be happy to recommend potential solutions and can discuss the possibility of our modifying a given device's internal filtering to meet your specific requirements. Contact our Applications Engineering Group for additional details.

Input Fusing

Certain applications and/or safety agencies may require the installation of fuses at the inputs of power conversion components. Fuses should also be used if the possibility of sustained, non-current-limited, input-voltage polarity reversals exists. For DATEL A-Series UWR 15 Watt DC/DC Converters, you should use slow-blow type fuses with values no greater than the following.

V _{IN} Range	Fuse Value
"D12" Models	3 Amps
"D24" Models	2 Amps
"D48" Models	1 Amp

Start-Up Threshold and Undervoltage Shutdown

Under normal start-up conditions, devices will not begin to regulate until the ramping-up input voltage exceeds the Start-Up Threshold Voltage (35V for "D48A" models). Once operating, devices will not turn off until the input voltage drops below the Undervoltage Shutdown/Lockout limit (34V for "D48A" models). Subsequent re-start will not occur until the input is brought back up to the Start-Up Threshold. This built-in hysteresis obviously avoids any indeterminate on/off situations at a single voltage.

Start-Up Time

The V_{IN} to V_{OUT} Start-Up Time is the interval between the time at which a ramping input voltage crosses the turn-on threshold point and the fully-loaded output voltage enters and remains within its specified accuracy band. Actual measured times will vary with input source impedance, external input capacitance, and the slew rate and final value of the input voltage as it appears to the converter.

The On/Off to V_{OUT} Start-Up Time assumes the converter is turned off via the On/Off Control with the nominal input voltage already applied to the converter. The specification defines the interval between the time at which the converter is turned on and the fully-loaded output voltage enters and remains within its specified accuracy band.

TEMPERATURE DERATING

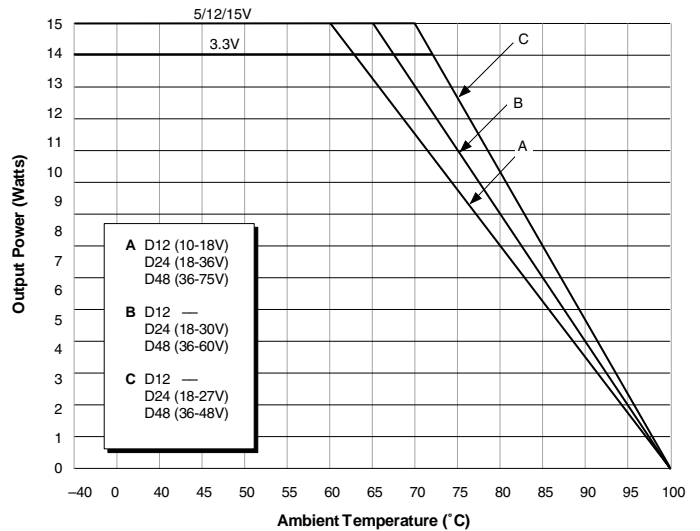

The thermal performance of A-Series UWR 15 Watt DC/DC Converters is depicted above. All devices, when operated at full load, in still ambient air, over their full specified input voltage range, can safely operate to +60°C, and subsequently must have their output power derated along curve "A" (half power at +80°C). As shown by curves "B" and "C," "D24" and "D48" models can reliably operate under higher temperature conditions if their input voltages are known to have more limited excursions. Model UWR-15/1000-D24A, for example, can operate under full load to +70°C if its input voltage is kept between 18 and 27 Volts. Contact DATEL's Applications Engineering Group if you need additional details.