

## Instruction Manual

### SLM 1352P

### Sound Level Meter

### Datalogger and USB Interface

EN FR IT DE ES

---

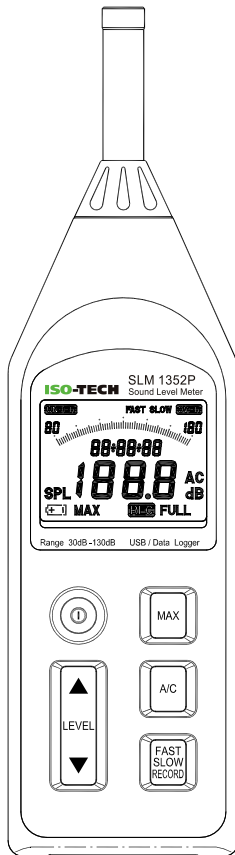

# CONTENTS

<b>Title</b>	<b>Page</b>
<b>1. INSTRUMENT CARE .....</b>	<b>1</b>
<b>2. FEATURES.....</b>	<b>2</b>
<b>3. MEASUREMENT PARAMETERS.....</b>	<b>3</b>
<b>4. SPECIFICATIONS .....</b>	<b>4</b>
<b>5. CONTROLS AND FUNCTIONS .....</b>	<b>10</b>
<b>6. DISPLAY DESCRIPTION .....</b>	<b>12</b>
<b>7. PREPARATION FOR USE .....</b>	<b>13</b>
<b>8. CALIBRATION PROCEDURE .....</b>	<b>15</b>
<b>9. MEASUREMENT PROCEDURE.....</b>	<b>16</b>
<b>10. SETTING THE CURRENT TIME AND DATE .....</b>	<b>17</b>
<b>11. STORE/ERASE RECORDED DATA .....</b>	<b>18</b>
<b>12. PRINTING DATA (OPTIONAL – 300XP PRINTER).....</b>	<b>19</b>
<b>13. OUTPUT CONNECTORS.....</b>	<b>20</b>
<b>14. ADJUSTMENT DATA FOR CALIBRATOR (B&amp;K TYPE 4226 PRESSURE MODE).....</b>	<b>21</b>
<b>15. TYPICAL INSTRUMENT FREQUENCY RESPONSE AT 0° INCIDENCE.</b>	<b>22</b>
<b>16. TYPICAL FREQUENCY RESPONSE DUE TO CASE REFLECTIONS AT 0° INCIDENCE .....</b>	<b>23</b>
<b>17. TYPICAL FREQUENCY RESPONSE FOR INSTRUMENT FITTED WITH WINDSCREEN AT 0° INCIDENCE.....</b>	<b>24</b>
<b>18. DIRECTIONAL CHARACTERISTICS OF THE COMPLETE INSTRUMENT .....</b>	<b>25</b>
<b>19. APPENDIX A FREQUENCY WEIGHTING NETWORK.....</b>	<b>28</b>
<b>20. APPENDIX B RMS DETECTION CIRCUIT AND TIME WEIGHTING .....</b>	<b>29</b>
<b>21. APPENDIX C INFLUENCE OF BACKGROUND NOISE .....</b>	<b>31</b>

**1. INSTRUMENT CARE**

- ❑ Do not attempt to remove the mesh cover from the microphone as this will cause damage and affect the accuracy of the instrument.
- ❑ Protect the instrument from impact. Do not drop it or subject it to rough handling. Transport it in the supplied carrying case.
- ❑ Protect the instrument from water, dust, extreme temperatures, high humidity and direct sunlight during storage and use.
- ❑ Protect the instrument from air with high salt or sulphur content, gases and stored chemicals, as this may damage the delicate microphone and sensitive electronics.
- ❑ Always turn the instrument off after use. Remove the batteries from the instrument if it is not to be used for a long time. Do not leave exhausted batteries in the instrument, as they may leak and cause damage.
- ❑ Clean the instrument only by wiping it with a soft, dry cloth or, when necessary, with a cloth lightly moistened with water. Do not use any solvents, alcohol or cleaning agents.

**2. FEATURES**

The ISO-TECH SLM 1352P Sound Level Meter complies with the requirements of IEC 61672-1:2003 standard for a Class 2 instrument.

The instrument contains several features which permit sound level measurements under a variety of conditions.

**Features include:**

- Ease of use.
- Easy to read large display.
- Five measurement ranges.
- Fast and Slow time weightings.
- A and C frequency weightings.
- Storage of up to 32000 measurement records.
- USB serial port for downloading records to a computer or real time analysis to a computer.
- Both AC and DC signal outputs are available from a single standard 3.5mm coaxial socket suitable for use with a frequency analyzer, level recorder, FFT analyzer, graphic recorder, etc.

### **3. MEASUREMENT PARAMETERS**

**The following parameters are used on the instrument.**

- A → “A” frequency weighting sound pressure level
- C → “C” frequency weighting sound pressure level
- FAST → Fast time weighting
- SLOW → Slow time weighting
- SPL → Current time-weighted sound pressure level
- SPL MAX → Maximum time-weighted sound pressure level

The various settings depend on the condition the instrument was in before it was last turned off.

## 4. SPECIFICATIONS

☐ Specifications apply to Model SLM 1352P fitted with Microphone model MC-21 and Microphone Preamplifier model AP-21

☐ **Applicable standards:** IEC61672-1: 2003 Class 2  
IEC60651: 1979 Type 2  
ANSI S1.4: 1983 Type 2

☐ **Measurement functions:**

- **Main processing functions**

Sound level: Current time-weighted sound pressure level A or current time-weighted sound pressure level C

Maximum time-weighted sound pressure level A or Maximum time-weighted sound pressure level C

- **Total range:** 30 to 130dB
- **Max. measurement level:** 130dB
- **Self-generated noise level:**

Typical values at 23°C using the nominal microphone equivalent capacitance of 27pF (30-90dB range)

Weighting	Electrical	Total
"A"	22.7dB	26.1dB
"C"	21.8dB	29.5dB

**Linearity operating range:** A-weighted, 1000Hz, 60dB dynamic range.

**Total linear operating range:**

In accordance with IEC 61672-1, A-weighted, 1000Hz: 30dB to 130dB.

**Level range selection:**

5 ranges in 10dB steps 30 to 90dB , 40 to 100dB  
50 to 110dB , 60 to 120dB  
70 to 130dB

### LINEAR OPERATING RANGES (L.O.R.)

**RANGE: 30 – 90 dB.** Test starting point 64 dB for all weightings and frequencies except 31.5Hz A-weighted, for which the starting point is 44 dB.

FREQUENCY Hz	WEIGHTING	L.O.R. dB	WEIGHTING	L.O.R. dB
31.5	A	36.1 – 50.6	C	39.5 – 87.0
1000	A	36.1 – 90.0	C	39.5 – 90.0
4000	A	36.1 – 90.0	C	39.5 – 89.2
8000	A	36.1 – 88.9	C	39.5 – 87.0

**RANGE: 40 – 100 dB.** Test starting point 74 dB for all weightings and frequencies except 31.5Hz A-weighted, for which the starting point is 54 dB.

FREQUENCY Hz	WEIGHTING	L.O.R. dB	WEIGHTING	L.O.R. dB
31.5	A	40.0 – 60.6	C	40.0 – 97.0
1000	A	40.0 – 100.0	C	40.0 – 100.0
4000	A	40.0 – 100.0	C	40.0 – 99.2
8000	A	40.0 – 98.9	C	40.0 – 97.0

**RANGE: 50 – 110 dB.** Test starting point 84 dB for all weightings and frequencies except 31.5Hz A-weighted, for which the starting point is 64 dB.

FREQUENCY Hz	WEIGHTING	L.O.R. dB	WEIGHTING	L.O.R. dB
31.5	A	50.0 – 70.6	C	50.0 – 107.0
1000	A	50.0 – 110.0	C	50.0 – 110.0
4000	A	50.0 – 110.0	C	50.0 – 109.2
8000	A	50.0 – 108.9	C	50.0 – 107.0

**RANGE: 60 – 120 dB.** Test starting point 94 dB for all weightings and frequencies except 31.5Hz A-weighted, for which the starting point is 74 dB.

FREQUENCY Hz	WEIGHTING	L.O.R. dB	WEIGHTING	L.O.R. dB
31.5	A	60.0 – 80.6	C	60.0 – 117.0
1000	A	60.0 – 120.0	C	60.0 – 120.0
4000	A	60.0 – 120.0	C	60.0 – 119.2
8000	A	60.0 – 118.9	C	60.0 – 117.0

**RANGE: 70 – 130 dB.** Test starting point 104 dB for all weightings and frequencies except 31.5Hz A-weighted, for which the starting point is 84 dB.

FREQUENCY Hz	WEIGHTING	L.O.R. dB	WEIGHTING	L.O.R. dB
31.5	A	70.0 – 90.6	C	70.0 – 127.0
1000	A	70.0 – 130.0	C	70.0 – 130.0
4000	A	70.0 – 130.0	C	70.0 – 129.2
8000	A	70.0 – 128.9	C	70.0 – 127.0

**Frequency range:** Overall characteristics including microphone: 31.5 to 8000Hz

**Frequency weighting: A,** meets the requirement of IEC 61672-1 for class 2 "A" weighting.

**C,** meets the requirement of IEC 61672-1 for class 2 "C" weighting.

**Time weighting (RMS detection): Fast,** according to IEC 61672-1 class 2.  
**Slow,** according to IEC 61672-1 class 2.

- **Reference conditions:**

**Type of the acoustic field:** Free

**Reference sound pressure level:** 94.0dB (related to 20 $\mu$ Pa)

**Reference level range:** 60 to 120dB

**Reference frequency:** 1000Hz

**Reference temperature:** +23 $^{\circ}$ C

**Reference relative humidity:** 50%RH

**Reference static pressure:** 101.325 kPa

**Reference incidence direction:** Perpendicular to the front of the microphone diaphragm.

- **Calibration:** Acoustic using calibrator ISO-TECH SLC 1356, B&K 4231 or equivalent.  
Calibration check frequency is 1000Hz.

**Nominal calibration level for the free field:** 94.1dB

**Nominal calibration level for the diffuse field:** 94.0dB

- **Frequency for acoustic testing:** 8000Hz.
- **Warm-up time:**  $\leq$ 2min
- **Sampling interval:** Bar graph indication  $\rightarrow$  125 ms approx.  
Numeric indication  $\rightarrow$  1 sec approx.
- **Data record capacity:** Data can be stored in the memory.  
Max. 32000 data can be stored.  
Max. 255 blocks can be split.
- **Microphone equivalent electrical impedance (electrical input device) :** Replace the microphone capsule with a series capacitance of 27pF +/- 3pF

- **Microphone:**

- **Model:** MC-21
- **Nominal diameter:** 1/2 inch electret condenser type
- **Sensitivity:** -37dB (0dB = 1V/Pa)
- **Frequency response:** 31.5Hz to 8000Hz
- **Capacitance:** 27pF

- **Reference direction and position:** Perpendicular to the front of the microphone diaphragm at its geometric centre.
- **Maximum input sound level:** 131dB at microphone for no damage.
- **Operating temperature:** -10°C to +50°C
- **Temperature coefficient:** Approx. 0.05dB/°C at 1000Hz
- **Dimensions:** 13.2dia x 14mm

**Frequency Response**

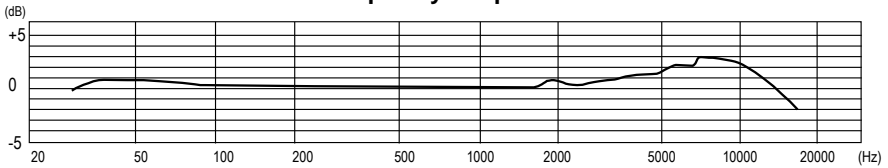

Freq units	31.5 Hz	63 Hz	125 Hz	250 Hz	500 Hz	1000 Hz	2000 Hz	4000 Hz	8000 Hz
dB	+0.6	+0.8	+0.2	+0.0	0.0	0.0	+0.8	+1.3	+3.0

Typical free-field response 0° incidence

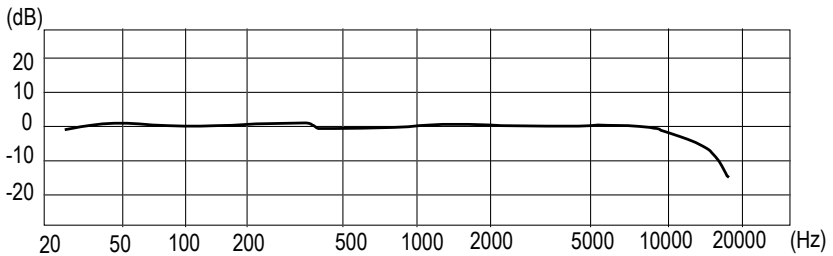

Freq units	31.5 Hz	63 Hz	125 Hz	250 Hz	500 Hz	1000 Hz	2000 Hz	4000 Hz	8000 Hz
dB	+0.1	+0.4	0.0	+0.5	-0.2	0.0	+0.2	0.0	-0.5

Typical diffuse-field response for random incidence

□ **Preamplifier:**

- **Model:** AP-21
- **Input impedance:** 470MΩ
- **Output impedance:** 550Ω at 1000Hz
- **Maximum input voltage:** 2.828V peak-to-peak at electrical input for no damage.

- **Measuring input (viewed from top of instrument):**

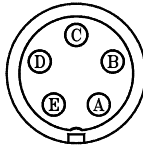

- A: ground
- B: ground
- C: +10V
- D: signal input
- E: N.C.

- **Display LCD**

- **Display screens:**

- 4 digit numerical indication of sound level, from 30.0 to 130.0dB with 0.1dB resolution.

- Bar-graph indication of current sound level with 1dB resolution.

- Sound level range indicator: 30–90dB, 40–100dB, 50–110dB, 60–120dB or 70–130dB in five ranges.

- Time display; year – month – day and hour: minute: second.

- **Display update rate:** 1 second

- **Display first indication:** Depends on the condition the instrument when it was last turned off.

- **Warning indications:**

- Out-of-range indications:

- OVER** displayed at upper limit of the range

- UNDER** displayed at lower limit of the range

- **Outputs**

- **AC output** (using selected frequency weighting)

- Output voltage:** 2V<sub>rms</sub> (at full-scale of the range)

- Output impedance:** 5k $\Omega$

- Load impedance:**  $\geq 1M\Omega$

- **DC output**

- Output voltage:** 10mV/dB

- Output impedance:** 5k $\Omega$

- Load impedance:**  $\geq 1M\Omega$

- **I/O connector:** Sound level meter control from and data output to a computer (USB)

- **Power requirements**

- **Qty 4 x 1.5V IEC R6P (size “AA”) manganese super heavy duty batteries or equivalent.**

- **Battery life:** Approx. 50 hours

- **External power source:** DC voltage from 5V to 12V

- Current rating:** Approx. 10mA @ 6V

**□ Ambient conditions:**

- **Operating conditions:** -10°C to +50°C, 30% to 90%RH non-condensing
- **Storage conditions:** -10°C to +60°C, <70%RH non-condensing
- **Effect of temperature:** < 0.5dB (-10 to +50°C)
- **Effect of humidity:** < 0.5dB (for 30%RH to 90%RH at 40°C, 1000Hz)
- **Effect of vibration:** A 40 Hz 1m/s vibration produces no noticeable effect.
- **Effect of magnetic field:** No noticeable effect.

**□ Compliance with standards:**

- **CE:** indicates compliance with applicable European Union Directives.
- **EMC Emission:** IEC 61000-6-3, Generic emission standard for residential, commercial and light industrial environments.  
No significant emissions from the instrument.  
IEC 61672-1, Instrumentation standard classification group X and performance class 2 sound level meter.
- **EMC Immunity:** IEC 61000-6-2, Generic standard-Immunity for industrial environments.  
No degradation in performance when subjected to 10V/m unmodulated.  
IEC 61672-1, Instrumentation standard classification group X and performance class 2 sound level meter.  
No permanent degradation of performance, loss of function, change of operating state or configuration, or loss or corruption of stored data due to ESD discharges as specified in the above standard.
- No degradation in performance when the instrument was subjected to ESD at 8kV per IEC 801-2.

**□ Dimensions:** Approx. 265x72x36 mm**□ Weight (including battery):** Approx. 380g**□ Supplied accessories:** Instruction manual, Batteries, Adjustment screwdriver, PC software, Windscreen, USB connecting cable, 3.5φ plug, Carrying case.**□ Optional equipment (Not supplied):** AC adaptor, Sound calibrator, Thermal printer connecting cable, Portable thermal printer.

## 5. CONTROLS AND FUNCTIONS

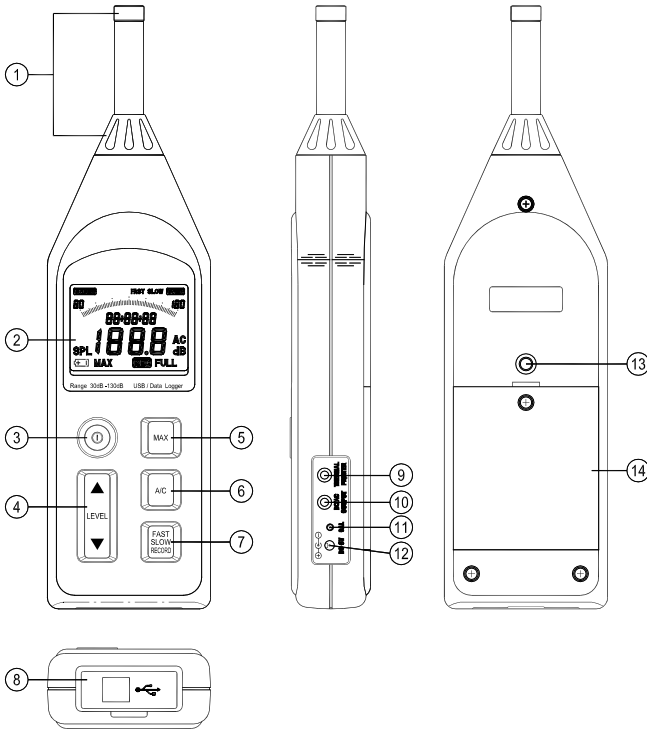

1. **Microphone and preamplifier:** The MC-21 microphone capsule is connected to the AP-21 preamplifier for normal operation. The microphone capsule may be carefully removed from the preamplifier and substituted with the appropriate electrical impedance (See sect. 4. "Specifications") for electrical verification of the instrument.
2. **Display:** The LCD shows the sound level as a numeric value and a bar graph. The display also shows the operation mode of the instrument, the selected measurement parameters and warning indications.
3. **Ⓚ Button:** Press to turn the instrument on and off.
4. **▲/▼ Button:**

▲

LEVEL

▼

  - ① Level range buttons: select the level range for the measurement. The following five settings are available: 30 to 90dB, 40 to 100dB, 50 to 110dB, 60 to 120dB, 70 to 130dB.
  - ② Press these buttons to increment or decrement setting values.



5. **Button:** Used for reading the maximum time-weighted sound level encountered during a measurement.  
Press this button to enter maximum recording mode. The “MAX” indicator will appear on the display. Press again to exit maximum recording mode.



6. **Button:** Sets the frequency weighting to A or C mode.



7. **Button:** ① Sets the time weighting to FAST or SLOW mode.  
**FAST:** uses a 125ms time-constant. This setting is used in most situations.  
**SLOW:** uses a 1s time constant, which smoothes out fluctuating levels.
- ② Data record mode: Press and hold this button for 3 seconds to enter data recording mode. The “RECORD” indicator will appear on the display and will flash to indicate recording is in progress. To exit data recording mode, press and hold for 3 seconds until the instrument returns to normal mode and the “RECORD” indicator disappears.
- ③ Erase all records: Turn off the instrument, press and hold down this button then turn on the instrument until the “CLR RECORD” indication appears on the display.

8. **I/O connector:** USB input/output connector for input of control signals and output of measurement data.

9. **Thermal printer output jack:** Connection for the 300XP printer.

10. **DC/AC output socket:** DC output signal corresponding to sound level.  
AC output signal with frequency weighting.

11. **CAL potentiometer:** Calibration potentiometer for level adjustment.

12. **External DC power supply socket:** Type 1.3 coaxial power connector; centre negative, nominal 6V DC.

13. **Tripod mounting:** ¼” - 20 UNC Female thread.

14. **Battery cover.**

## 6. DISPLAY DESCRIPTION

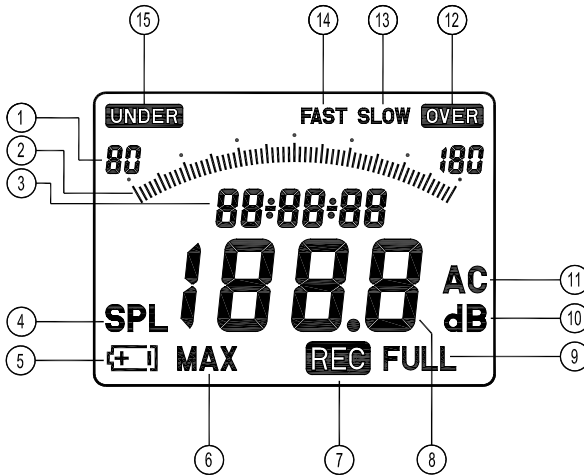

1. Sound level range indicator (5 ranges): 30–90dB, 40–100dB, 50–110dB, 60–120dB and 70–130dB
2. Bar graph shows the current sound level (1dB resolution).
3. Date/time and maximum SPL measurement time.  
This indicator shows the “year - month - day” or “hour: minute: second”.  
DATE: Date (year - month - day).  
TIME: Time (hour: minute: second)
4. SPL: Time-weighted sound level reading “Sound Pressure Level”
5. Low-battery indication
6. MAX: Maximum time-weighted sound level reading.
7. RECORD: Data records indicator
8. Sound level reading (0.1dB resolution): 30.0 – 130.0dB
9. FULL: Data records full indicator
10. dB: Sound level unit
11. A, C: “A” Frequency weighting or “C” Frequency weighting indicator.
12. **OVER**: Over-range indicator.
13. SLOW: “Slow” time weighting indicator
14. FAST: “Fast” time weighting indicator
15. **UNDER**: Under-range indicator.

## 7. PREPARATION FOR USE



### Power Supply

The instrument can be powered by internal batteries, or for extended operation by an optional external 6V DC supply such as a suitable AC mains adapter or battery pack. Rechargeable batteries may be used in the instrument, but cannot be recharged when fitted as the instrument is not designed to recharge batteries.

Before inserting or replacing the batteries and before connecting the AC adaptor, be sure to turn the instrument off.

#### 1. Battery Installation

When the low battery indication symbol “” appears on the display, there is insufficient power to make accurate measurements and the batteries must be replaced.

- ① Before replacing the batteries, press the  button to turn off the instrument.
- ② Use a screwdriver to loosen the screw in the battery cover. Remove the cover from the battery compartment. Retain the screw and cover.
- ③ Observing correct polarity as indicated in the compartment, insert four batteries of the type given in section 4. “Specifications”.
- ④ Refit the battery cover and screw. Use a screwdriver to tighten the screw.
- ⑤ Press the  button to turn on the instrument and check for correct operation.

**Note:** Take care not to reverse the (+) and (-) polarity when inserting the batteries, otherwise the instrument may be damaged.

Always replace all four batteries at the same time.

Do not mix old and new batteries or batteries of different types.

Remove the batteries from the instrument if it is not to be used for a month or longer.

#### 2. Using an external power source.

Insert the plug of the AC adaptor or external battery pack into the DC 6V (DC source from 5V to 12V) socket on the side of the instrument. When a connector is inserted into this socket, the internal batteries will be disconnected and the instrument will be powered from the external source. The low battery symbol “” will appear on the display if the external voltage is insufficient for the instrument to provide accurate measurements.

**Note:** Ensure the external power source is connected with the polarity as indicated in the following diagram, otherwise damage may be caused to the instrument and external power source.

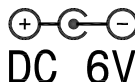

### 3. Windscreen

When making measurements outdoors in strong winds or when measuring air conditioning equipment or similar, wind noise and strong air movements at the microphone can cause measurement errors. Such effect can be reduced by using the windscreen.

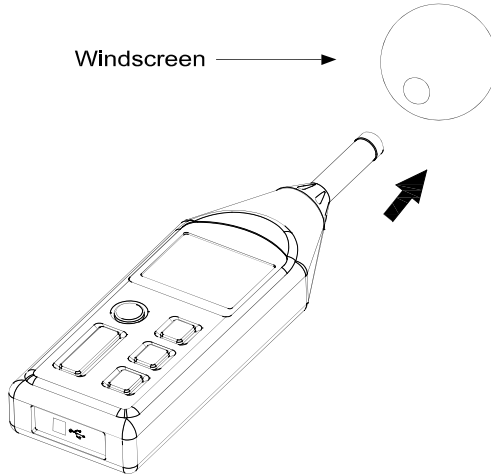

### 4. Tripod Mounting

For long-term measurements, the instrument may be mounted on a standard camera tripod using the integral  $\frac{1}{4}$ " x 20 UNC mounting thread.

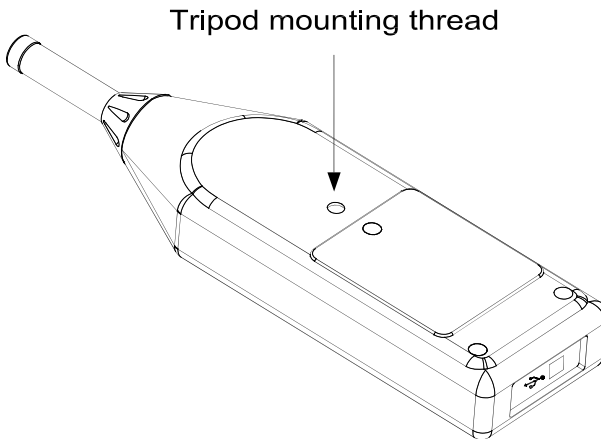



**8. CALIBRATION PROCEDURE**

Most national standards recommend that you calibrate your sound level meter before each set of measurements and check the calibration after each set.

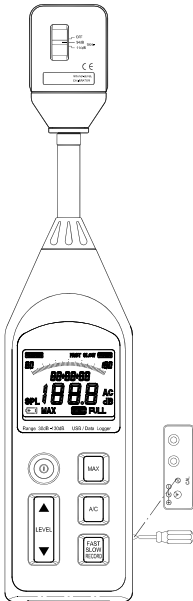
The procedure to check/adjust the displayed sound level in response to acoustic calibrator types SLC 1356 or B&K 4231 (or equivalent) is as follows:



1. Turn off the sound calibrator.
2. Press the  button to turn on the instrument.
3. Use the “  ” and “  ” buttons to select the 60 to 120dB reference sound level range.



4. Use the  button to select “A” frequency weighting.

5. Use the  button to select “FAST” time weighting.

6. Insert the microphone very carefully and slowly all the way into the sound calibrator coupling orifice.
7. Switch on the 1000Hz sound calibrator in its nominal 94 dB level setting.
8. Adjust the CAL potentiometer of the instrument, until the display reading for diffuse field is the same as the certified pressure level of the calibrator, or is 0.1 dB higher than this pressure level for free-field. This applies to calibrators type SLC 1356 or B&K4231.

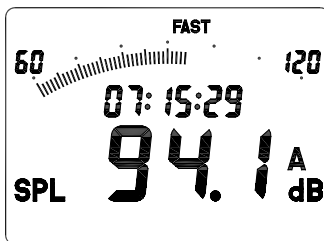

9. Set the power switch of the sound calibrator to OFF.
10. Remove the microphone very carefully and slowly from the coupler.

## 9. MEASUREMENT PROCEDURE

### Sound level measurement

1. Press the  button to turn on the instrument. The initial state depends on the condition the instrument was in before it was last turned off.



2. Press the  button to select the desired frequency weighting. For normal sound level measurements, select the "A" setting.



3. Press the  button to select the desired time weighting (dynamic characteristics). Normally, the "FAST" setting should be used.
4. When performing measurement according to IEC or other standards, the frequency weighting and time weighting setting required by the standard should be selected.







5. Press the  buttons to select desired level range. Choose a setting in which the bar graph indication registers approximately the middle of the range. If the "**OVER**" indicator appear during measurement, the upper limit of the selected range has been exceeded. Increase the range setting until the symbol remains off during measurement. Similarly, if the "**UNDER**" indicator appears, reduce the range setting until the symbol remains off during measurement. Both indicators are non-latching and will clear when the correct range is selected.
6. The numeric level indication shows the currently measured sound level. The reading is updated once every second.







7. Press the  button to record the maximum time-weighted sound level encountered during a measurement period; the "MAX" indicator will appear on the display. Press this button again to exit this mode.

**10. SETTING THE CURRENT TIME AND DATE**

Date and time information is stored with each record block. Therefore, it is important to make sure that this information is correct.

1. Press  button turn off the meter.
2. Press and hold down  button, then press  button turn on the meter, enter the current date and time setting mode.
3. A flashing cursor indicates the currently selected parameter (the second), press  and  buttons to set the current second.

4. Press  button move to the next parameter (the minute), press  and  buttons to set the current minute.
5. Repeat step 4 until you have set the current hour, day, month, and year.





6. Press  button to store the new date and time, and exit this mode.

## 11. STORE/ERASE RECORDED DATA

The instrument incorporates a memory which can be used to store measurement data.

The maximum has a data capacity of 32000 readings which can be split into 255 blocks of records.

### 1. Setting the record sampling interval time.

- ① Press  button turn off the meter.
- ② Press and hold down  button then turn on the meter, enter to sampling interval time setting mode, the “intr” symbol is displayed.
- ③ A flashing cursor indicates the currently parameter (the second), press  and  buttons to set desired sampling interval time (from 1 second to 255 seconds)



- ④ Press  button to stored the setting and exit this mode.

2. To record data, press and hold the “” button for 3 seconds to enter data recording mode. The “RECORD” indicator will appear on the display and will flash to indicate recording is in progress. To exit data recording mode, press and hold for 3 seconds until the instrument returns to normal mode and the “RECORD” indicator disappears.







3. When the memory is filled (32000 data or 255 blocks is full used), the “RECORD FULL” symbol will appear on the display.

4. The recorded data can only be reviewed after it has been downloaded to a PC. Recorded data cannot be displayed on the instrument.

5. To erase stored data, press the  button to turn the instrument off. Press and hold

down the “” button, then press the  button to turn the instrument on. “CLR RECORD” will appear on the display and all stored data will be erased.

**12. PRINTING DATA (OPTIONAL – 300XP PRINTER)**

1. Using the cable connect the meter and the printer.
2. Turn on the printer.
3. Setting the meter printing interval time
  - ① Press  button turn to off the meter.
  - ② Press and hold down  button then turn on the meter, enter the sampling interval time setting mode, the “intr” symbol is displayed.
  - ③ A flashing cursor indicates the current parameter (the second), press  and  buttons to set desired sampling interval time (from 1 second to 255 seconds)
  - ④ Press  button to stored the setting and exit this mode.
4. Press and hold down  button, then press  button turn on the meter, enter to printing data mode.

**13. OUTPUT CONNECTORS****AC Output:**

An AC signal corresponding to the frequency-weighted signal is available at this connector.

Output voltage:  $2V_{rms} \pm 100mV_{rms}$  (scale upper limit)

Output impedance: approx.  $5k\Omega$

Load impedance:  $\geq 1M\Omega$

The output voltage when the instrument is in calibration mode (-6dB from scale upper limit, 1000Hz sine wave) is  $0.5V_{rms}$ .

**DC Output:**

A level-converted DC signal generated by RMS detection and logarithmic compression is available at this connector. The signal reflects the frequency and time weighting settings of the instrument.

Output voltage:  $10mV \pm 0.1mV/dB$

Output impedance: approx.  $5k\Omega$

Load impedance:  $\geq 1M\Omega$

The output voltage when the instrument is reading 94dB is nominally 0.94V DC.

**14. ADJUSTMENT DATA FOR CALIBRATOR (B&K TYPE 4226 PRESSURE MODE)**

Freq units	31.5 Hz	63 Hz	125 Hz	250 Hz	500 Hz	1000 Hz	2000 Hz	4000 Hz	8000 Hz
dB	+0.2	+0.3	+0.1	-0.1	-0.2	-0.1	0	+1.2	+3.9

**15. TYPICAL INSTRUMENT FREQUENCY RESPONSE AT 0° INCIDENCE**

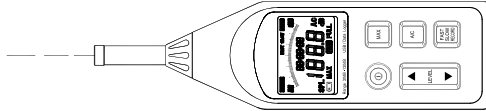

Freq units	31.5 Hz	40 Hz	50 Hz	63 Hz	80 Hz	100 Hz	125 Hz	160 Hz	200 Hz	250 Hz	315 Hz	400 Hz	500 Hz
0deg dB	1.6	2.3	1.1	1.2	1.1	1.0	0.9	1.2	0.4	0.0	0.5	0.5	0.3
Freq units	630 Hz	800 Hz	1000 Hz	1250 Hz	1600 Hz	2000 Hz	2500 Hz	3150 Hz	4000 Hz	5000 Hz	6300 Hz	8000 Hz	
0deg dB	0.2	0.2	0.0	-0.3	0.2	0.2	1.2	2.3	2.3	2.9	4.5	3.4	

**16. TYPICAL FREQUENCY RESPONSE DUE TO CASE REFLECTIONS AT 0°  
INCIDENCE**

Freq units	31.5 Hz	63 Hz	80 Hz	100 Hz	125 Hz	160 Hz	200 Hz	250 Hz	315 Hz	400 Hz	500 Hz	630 Hz
Case Reflections in dB	-0.2	-0.1	0.0	0.0	-0.1	-0.1	-0.1	-0.1	-0.1	0.5	0.1	0.2
Freq units	800 Hz	1000 Hz	1250 Hz	1600 Hz	2000 Hz	2500 Hz	3150 Hz	4000 Hz	5000 Hz	6300 Hz	8000 Hz	
Case Reflections in dB	-0.1	0.0	0.0	-0.4	0.4	0.0	1.0	0.2	0.8	-1.3	-1.0	

Absolute effect at 1000Hz = 0.0 dB

**Case reflections for an ISO-TECH 1352P meter fitted with an MC-21 microphone as per IEC 61672-1 and IEC 60651, relative to 1000Hz.**

**17. TYPICAL FREQUENCY RESPONSE FOR INSTRUMENT FITTED WITH WINDSCREEN AT 0° INCIDENCE**

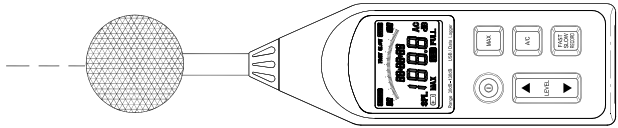

Freq units	31.5 Hz	63 Hz	80 Hz	100 Hz	125 Hz	160 Hz	200 Hz	250 Hz	315 Hz	400 Hz	500 Hz	630 Hz
Windshield Effects in dB	-0.2	-0.2	-0.1	-0.1	-0.2	-0.2	-0.2	-0.2	-0.1	-0.2	-0.1	-0.1
Freq units	800 Hz	1000 Hz	1250 Hz	1600 Hz	2000 Hz	2500 Hz	3150 Hz	4000 Hz	5000 Hz	6300 Hz	8000 Hz	
Windshield Effects in dB	-0.1	0.0	0.1	0.1	0.1	0.4	0.5	0.4	0.4	0.6	0.4	

Absolute effect at 1000Hz = +0.2 dB

**Frequency response effects for a 65mm dia. windshield fitted to an ISO-TECH 1352P meter fitted with an MC-21 microphone as per IEC 61672-1 and IEC 60651, relative to 1000Hz**

**18. DIRECTIONAL CHARACTERISTICS OF THE COMPLETE INSTRUMENT**

The directional characteristics of a microphone give a measure of its differing sensitivity for sound waves arriving from various angles. Since the pre-polarized condenser microphone used in the instrument is a pressure-sensitive type, it should be equally sensitive in all directions. However, refraction and cavity effects cause certain microphone directional characteristics at high frequencies. The diagrams below show the directional characteristics of the complete instrument with the microphone MC-21.

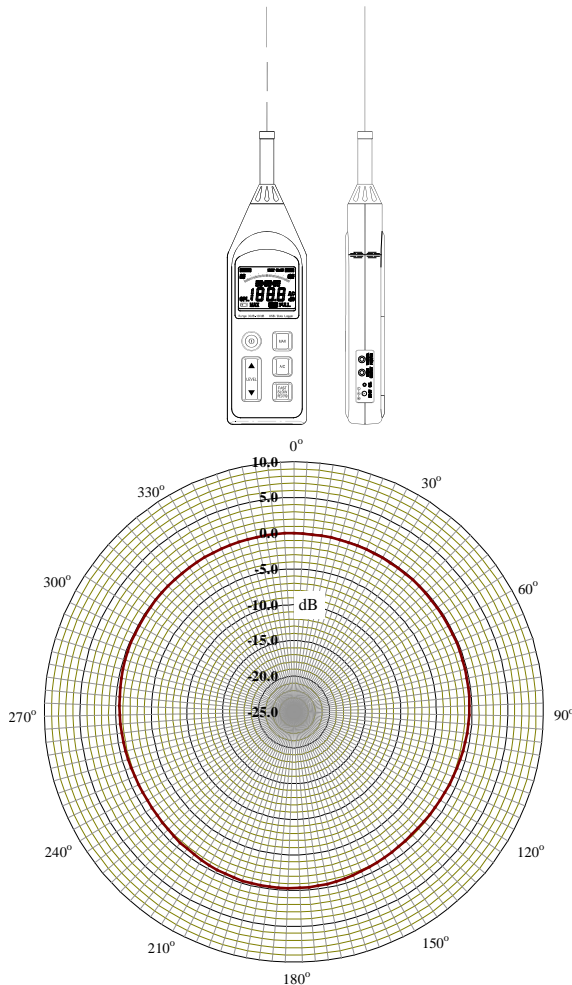

**Directional characteristics for frequency equal to 1000Hz**

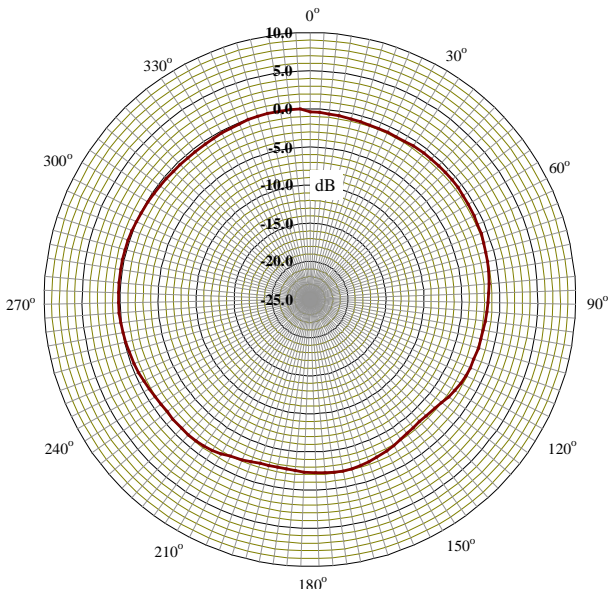

**Directional characteristics for frequency equal to 2000Hz**

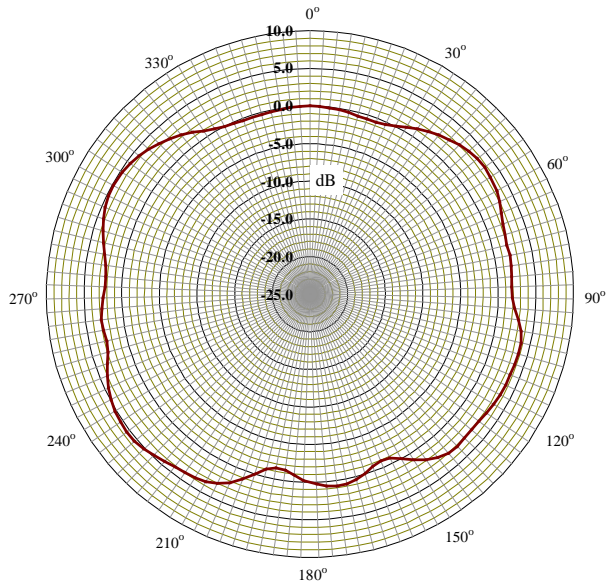

**Directional characteristics for frequency equal to 4000Hz**

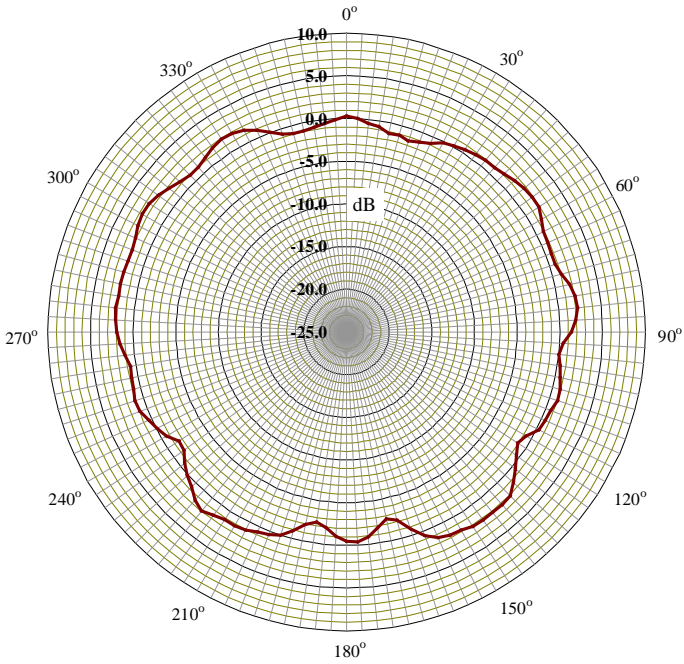

**Directional characteristics for frequency equal to 8000Hz**

**19. APPENDIX A FREQUENCY WEIGHTING NETWORK**

The SLM 1352P provides frequency weightings A, and C. The electrical characteristics of the weighting network at AC output connector are as shown below.

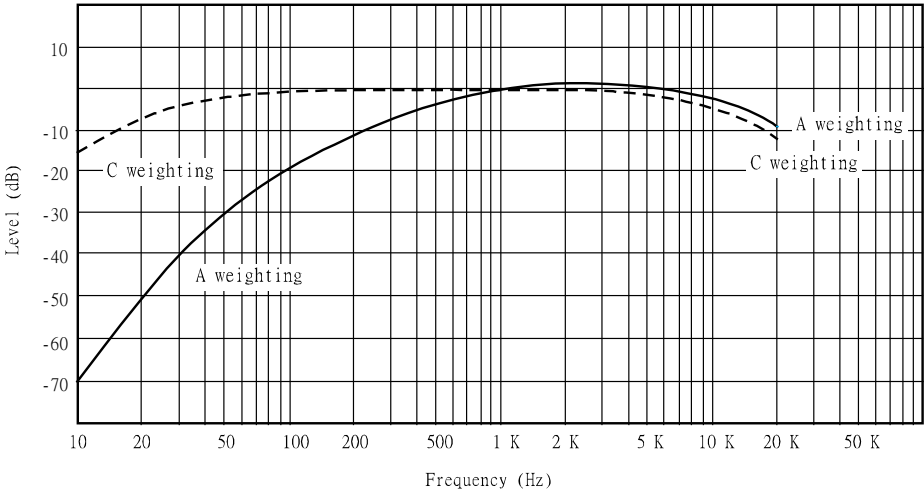

Frequency weighting characteristics

The human perception of a sound depends not only on the sound pressure level, but also on the frequency. At high or low frequencies, a sound is felt to be less loud than a sound of equal level in the midrange. The frequency weighting A compensates for this effect and produces measurement results which are close to the perceived sound level. For this reason, this type of frequency weighting is widely used for purposes such as sound level evaluation.

The frequency weighting C curve produces almost flat response, but with a roll off below 31.5Hz and above 8000Hz. This is suitable for sound pressure level measurements in situations with unwanted low-frequency or high-frequency components.

**20. APPENDIX B RMS DETECTION CIRCUIT AND TIME WEIGHTING**

The sound level meter uses rms detection. The effective value E (rms) is defined by the following equation.

$$E(rms) = \sqrt{\frac{1}{T} \int_0^T e^2 dt}$$

The voltage e which changes over time is raised to the power of 2, and integration for the time interval T is performed. The result is divided by T and the square root is extracted. The circuit configuration for performing the above mathematical operation looks as follows.

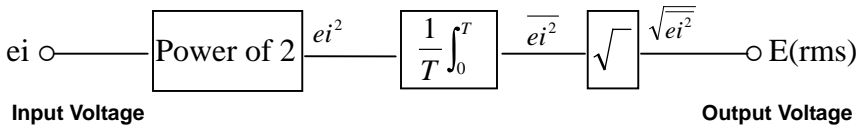

During sound level measurements, the level often fluctuates drastically, which would make it difficult to evaluate readings if some kind of averaging were not applied. Sound level meters therefore provide the capability for index weighting (index averaging) using the rms circuit. The parameters of this weighting process are called the time weightings, determined by the time constant (see next page).

Sound level meters usually have a F(Fast) and S(Slow) setting for the time weighting. The time range that is considered for averaging is narrow in the F(Fast) setting and wide in the S(Slow) setting. In the F(Fast) setting, the instantaneous level has a larger bearing on the displayed value than in the S(Slow) setting. From the point of view of the measurement objective, the F(Fast) setting is more suitable to situations with swiftly changing sound level, whereas the S(Slow) setting yields a more broadly averaged picture. The F(Fast) setting is more commonly used, and sound pressure level values given without other indication are usually made with F(Fast) characteristics.

Time weightings and time constant

Time Weightings	Time constant	
	Rise time	Decay time
F(Fast)	125ms	125ms
S(Slow)	1s	1s

The time weighting network of the sound level meter performs index averaging on the square of the sound pressure signal. The equivalent circuit is shown at right.  $\tau$  is the time constant, which equals CR.

The response of the index averaging circuit to a single burst signal is shown below.

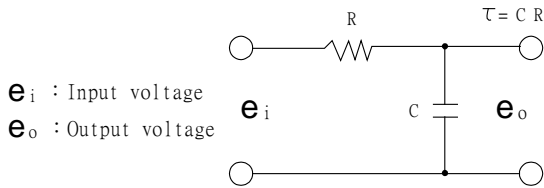

Equivalent electrical circuit

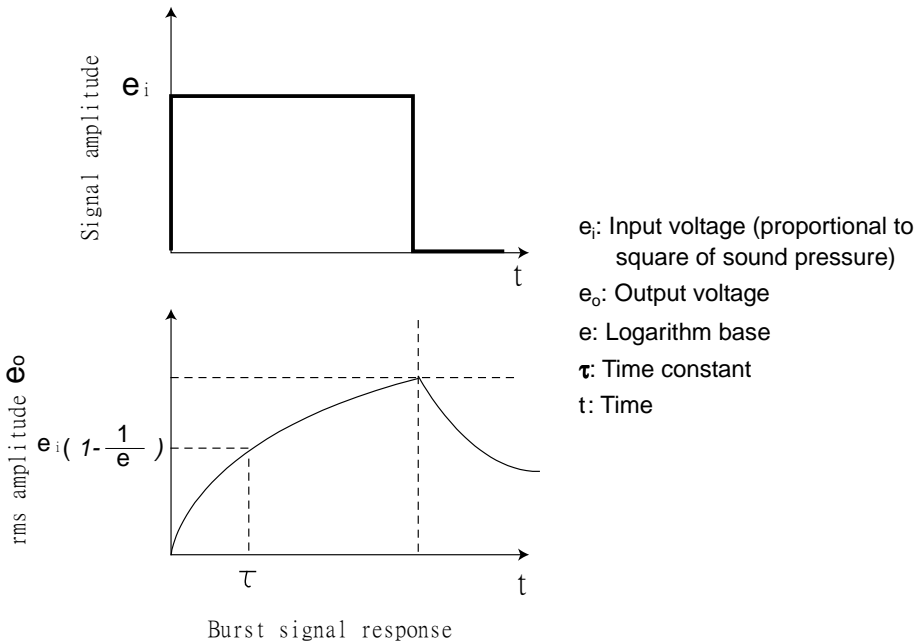

**21. APPENDIX C INFLUENCE OF BACKGROUND NOISE**

When measuring a certain sound in a certain location, all other sounds present at that location except the measurement target sound are background noise (also called ambient noise or dark noise). Since the sound level meter will display the combination of target sound and background noise, the amount of background noise must be taken into consideration when determining the level of the target sound.

If the difference between the instrument reading in absence of the target sound and the reading with the target sound is more than 10dB, the influence of background noise is small and may be disregarded. If the difference is less than 10dB, the values shown in the table below may be used for compensation, to estimate the level of the target sound.

**Background noise compensation**

<b>Display reading difference with and without target sound (dB)</b>	4	5	6	7	8	9
<b>Compensation value (dB)</b>	-2			-1		

If for example the measured sound level when operating a machine is 70dB, and the background noise level when the machine is not operating is 63dB, the compensation value for the difference of 7dB is -1dB. Therefore the sound level of the machine can be taken to be 70dB + (-1dB) = 69dB.

The above principle for compensating the influence of the background noise assumes that both the background noise and the target sound are approximately constant. If the background noise fluctuates, or contains very different spectral content and especially if it is close in level to the target sound, compensation is difficult and will often be meaningless.