

DETAILS

Product Number	F14304_FLORENCE-1R-Z90
Family	Florence
Type	Lens
Color	clear
Diameter	19,5 x 286 mm
Height	7 mm
Style	rectang
Optic Material	PMMA
Holder Material	
Fastening	glue
Status	ready
ROHS Compliant	Yes
Date Updated	27/03/2015



OPTICAL PROPERTIES

LED	Viewing	Light	Effi-	cd/lm	Connector
	Angle	Beam	ciency		
Luxeon 3030 2D	88+108 deg	WWW-class	92 %	0.420	-
MP-2016	89+108 deg	WWW-class	93 %	0.420	-
Duris S5 (2 chip)	90+113 deg	WWW-class	94 %	0.400	-
NF2x757D	90+110 deg	WWW-class	93 %	0.400	-
LM302A	90+108 deg	WWW-class	93 %	0.410	-
SEOUL 3030	90+109 deg	WWW-class	92 %	0.410	-
Fortimo LED Line 1ft 1100lm 8x0 1R xV290+110 deg	90+110 deg	WWW-class	94 %	0.410	-
LM561B	91+109 deg	WWW-class	93 %	0.390	-
Luxeon 3535	92+110 deg	WWW-class	93 %	0.390	-
XH-B/G	97+117 deg	WWW-class	90 %	0.350	-

H G F E D C B A

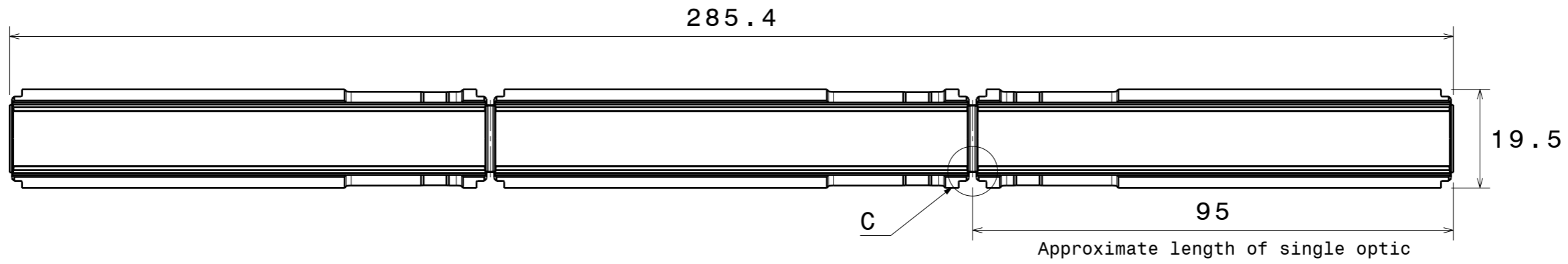

Bottom view

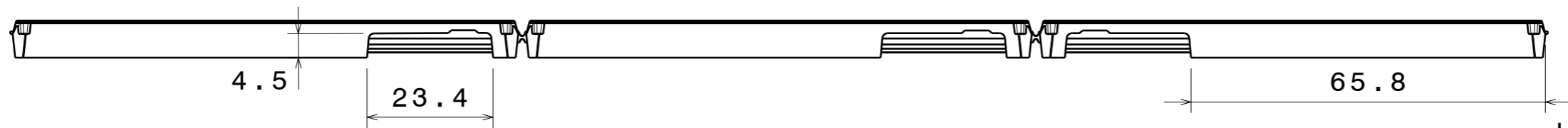

Left view

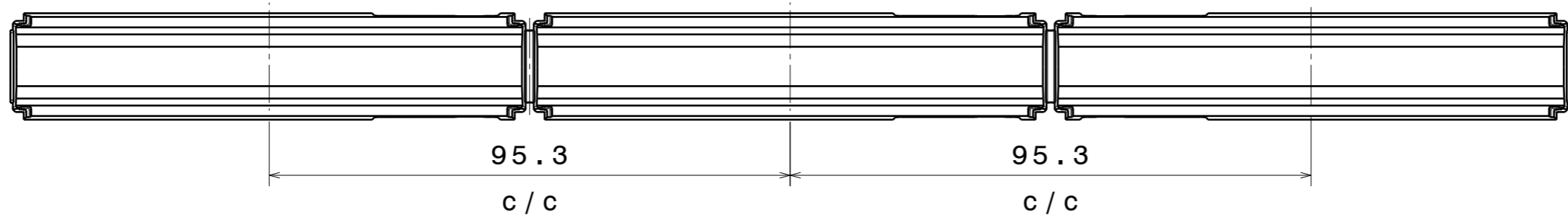

Top view

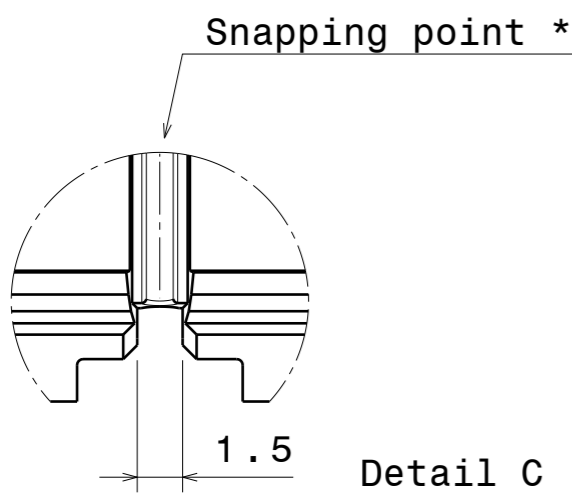

Detail C
Scale 4:1

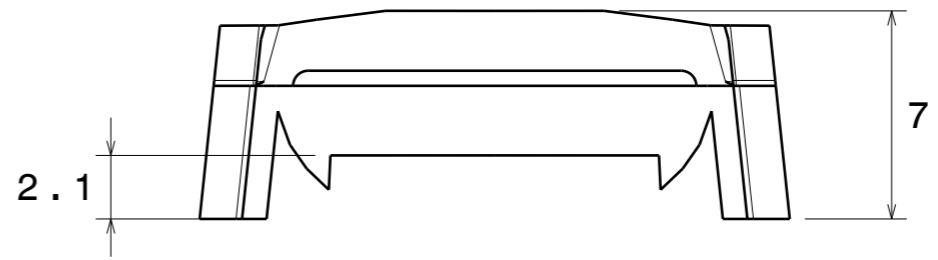

Front view
Scale 4:1

* Optics can be snapped along this line and used also as single parts.

Tolerances if not otherwise shown
According to DIN ISO 2768-1
Linear measures:
Up to 30mm class M, otherwise class C.
According to DIN ISO 2768-2
Form and position: class L

LEDiL LediL Oy
Salorankatu 10
FIN 24240 SALO
Finland

THIRD ANGLE PROJECTION:

DRAWING TITLE
Datasheet FLORENCE-1R

This drawing is the property of LEDiL Oy. It may not be reproduced, copied or communicated without a written agreement with LEDiL Oy.

SIZE	PART NUMBER		
A3	-		

SCALE	1:1	WEIGHT	-	SHEET	1/1
-------	-----	--------	---	-------	-----

H G B A

Ledil F14304_FLORENCE-1R-Z90_(Luxeon_3030_2D) / LDC (Linear)

Luminaire: Ledil F14304_FLORENCE-1R-Z90_(Luxeon_3030_2D)
Lamps: 1 x Luxeon_3030_2D_x22_(L130-4080003000W21)
_1601.44lm@200mA_CCT=4000K_P=12.8W_I=0.2A

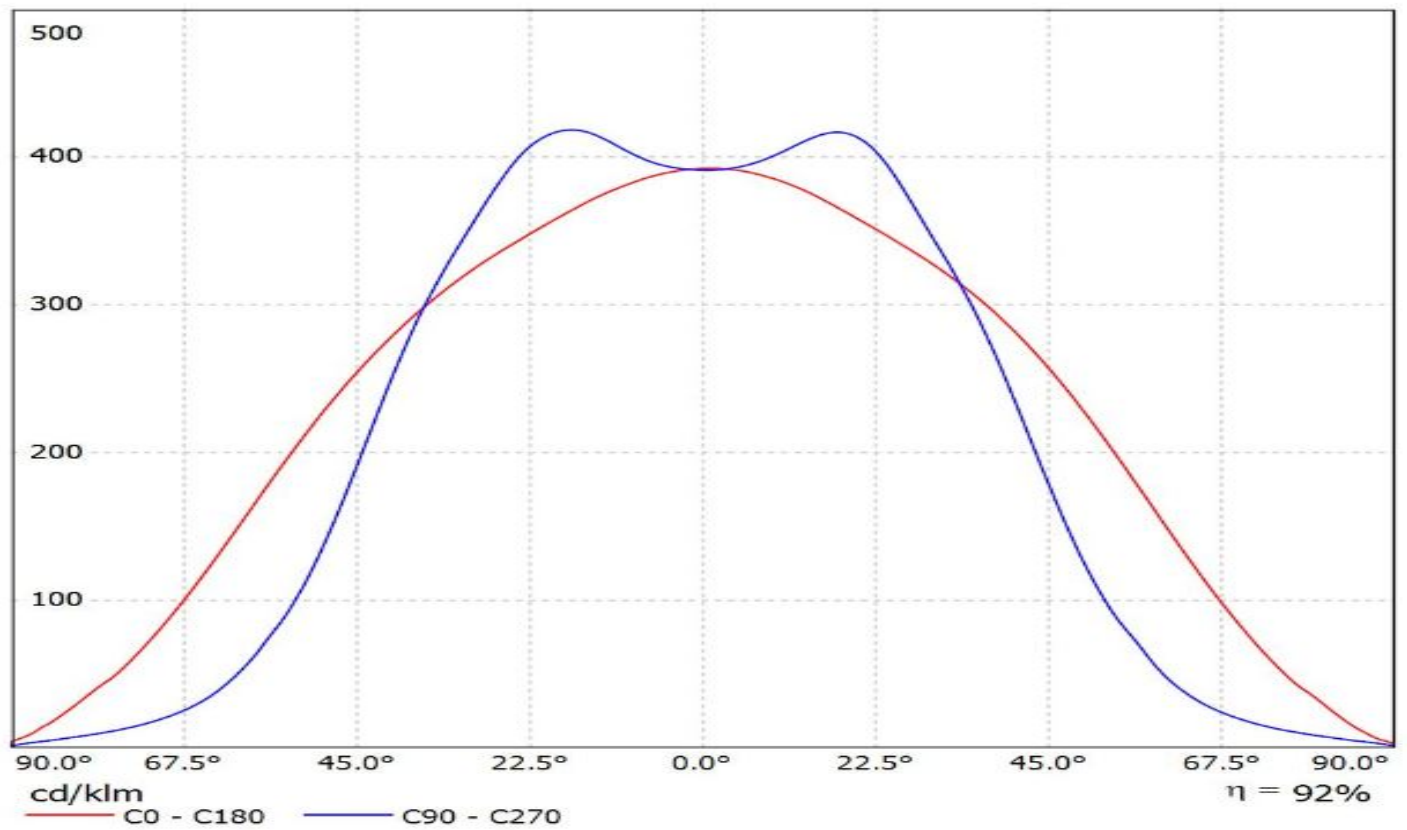

Ledil F14304_FLORENCE-1R-Z90_(Luminus_MP-2016) / LDC (Linear)

Luminaire: Ledil F14304_FLORENCE-1R-Z90_(Luminus_MP-2016)

Lamps: 1 x Luminus_MP-2016_1x22_(LUMMP-1100-30-80)_471.904lm@120mA_P=4W_I=0.12A

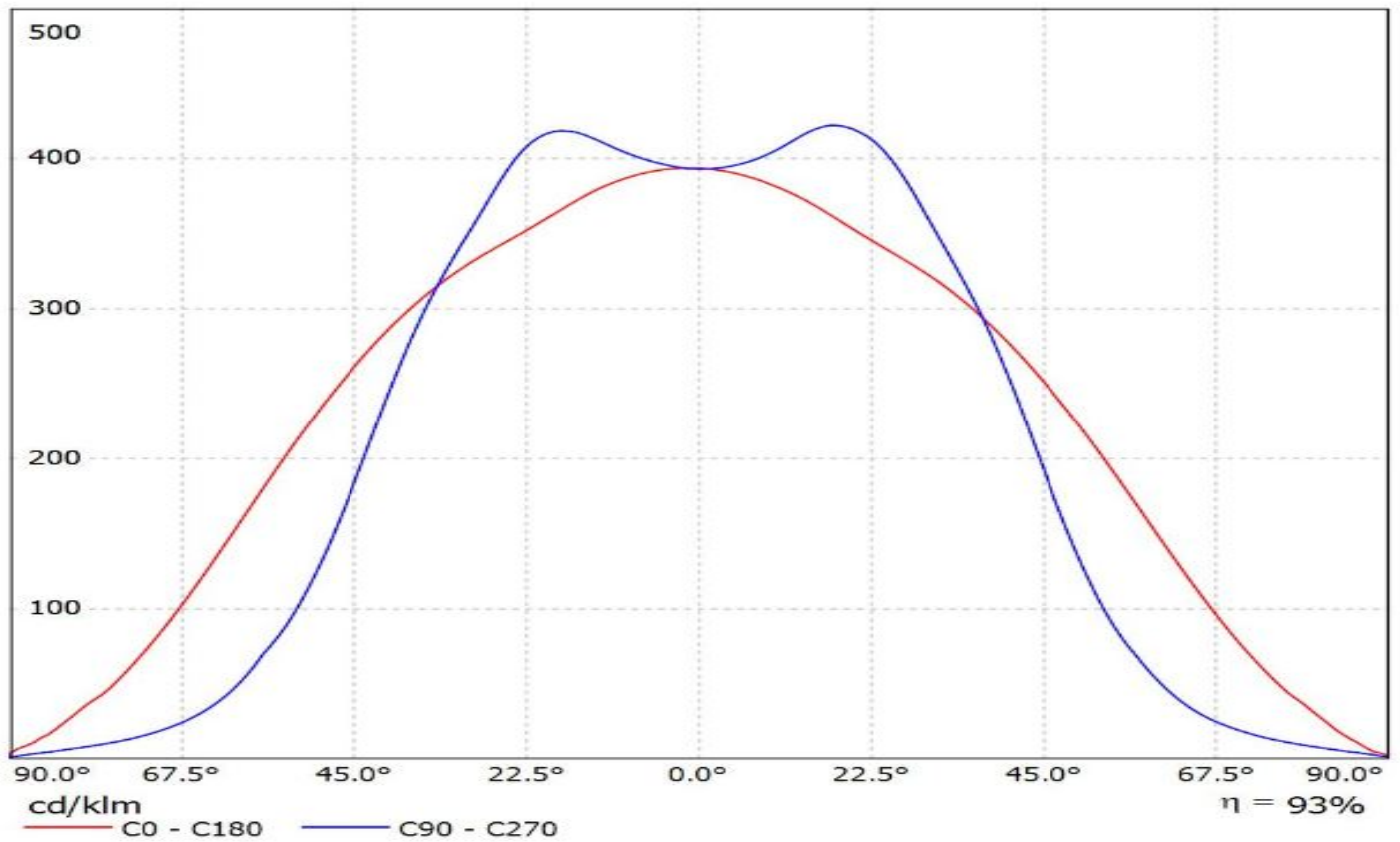

Luminaire: Ledil F14304_FLORENCE-1R-Z90_(Duris_S5)

Lamps: 1 x Osram_Duris_S5_(GW_PSLRS1.ÉC-LQLS-5H7I-1)_993.467lm@100mA_P=8W_I=0.1000A

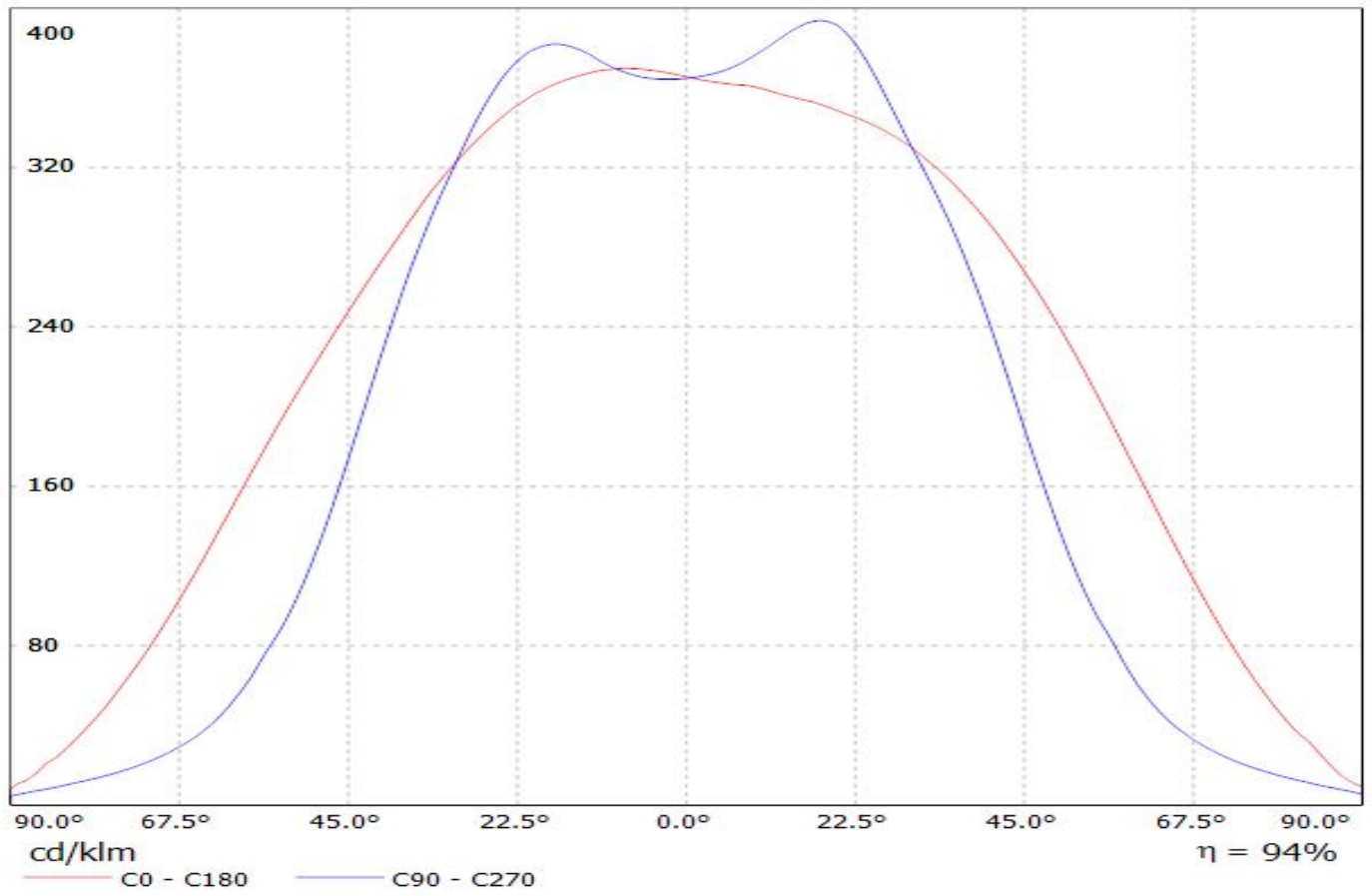

Ledil F14304_FLORENCE-1R-Z90_(NF2x757D) / LDC (Linear)

Luminaire: Ledil F14304_FLORENCE-1R-Z90_(NF2x757D)

Lamps: 1 x Nichia_NF2x757D_2chip_x22 (NF2W757DRT)_2050.61lm@200mA_P=12.95W_I=0.2A

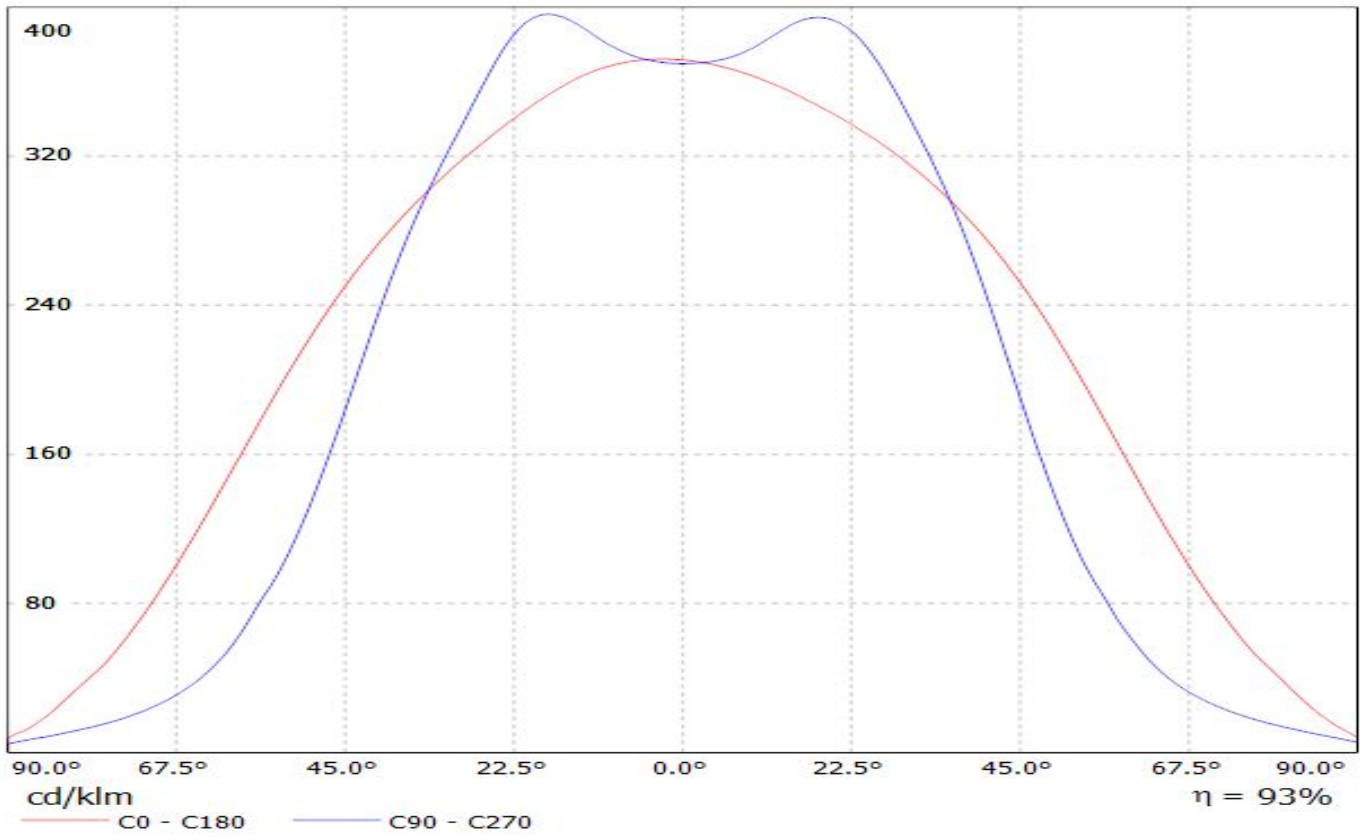

Luminaire: LEDiL Oy F14304_FLORENCE-1R-Z90_(LM302A)

Lamps: 1 x Samsung_LM302A_865.46lm@100mA_P=6.64694W_I=0.1001A

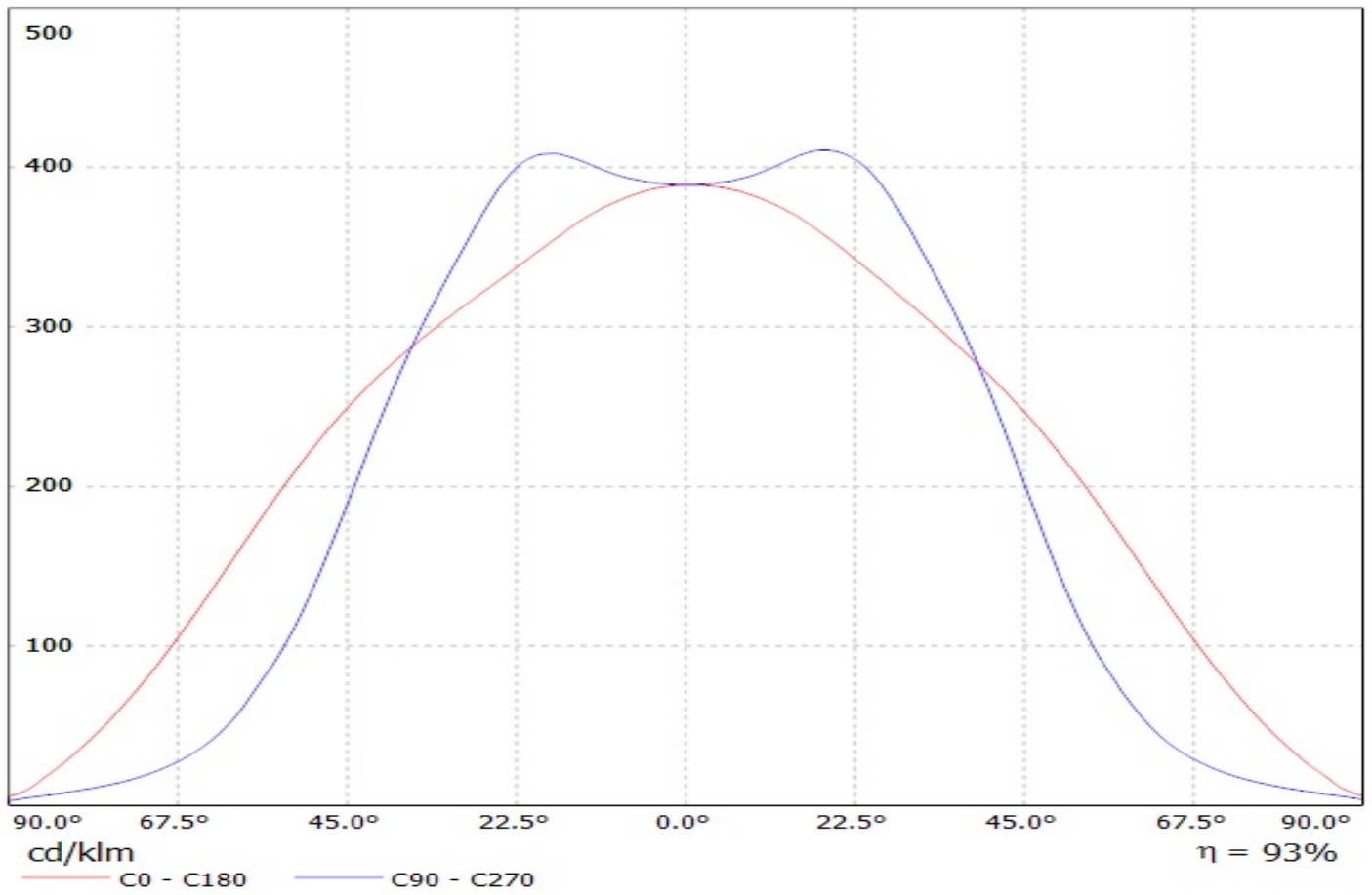

Ledil F14304_FLORENCE-1R-Z90_(Seoul_3030) / LDC (Linear)

Luminaire: Ledil F14304_FLORENCE-1R-Z90_(Seoul_3030)

Lamps: 1 x Seoul_3030_x11_(STW8C2SA)_785.296lm@100mA_P=6.5W_I=0.1A

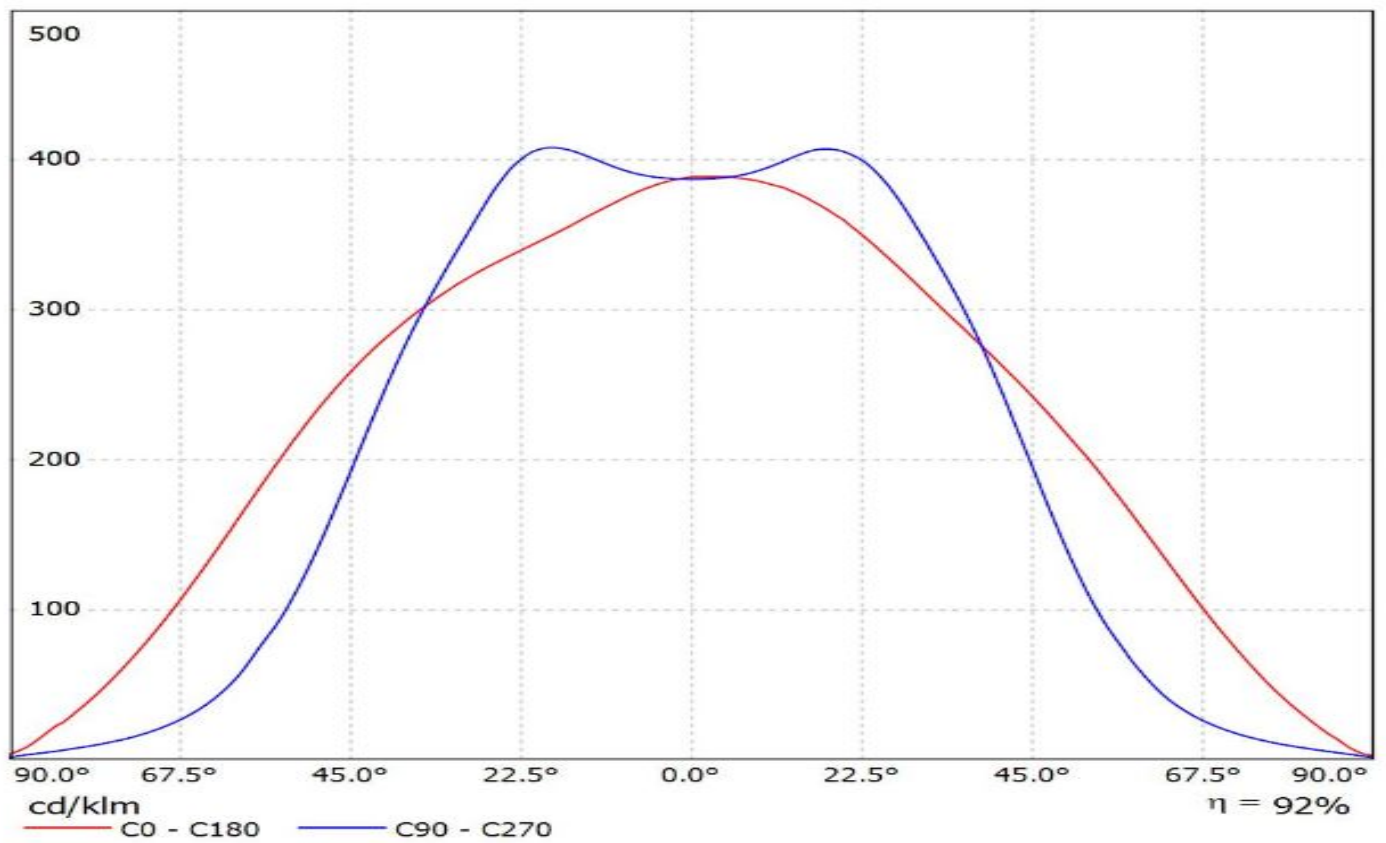

Luminaire: LEDiL Oy F14304_FLORENCE-1R-Z90

Lamps: 1 x Fortimo LED Line 1ft 1100lm 1R_1033.71lm@250mA_P=8.41851W_I=249.8mA

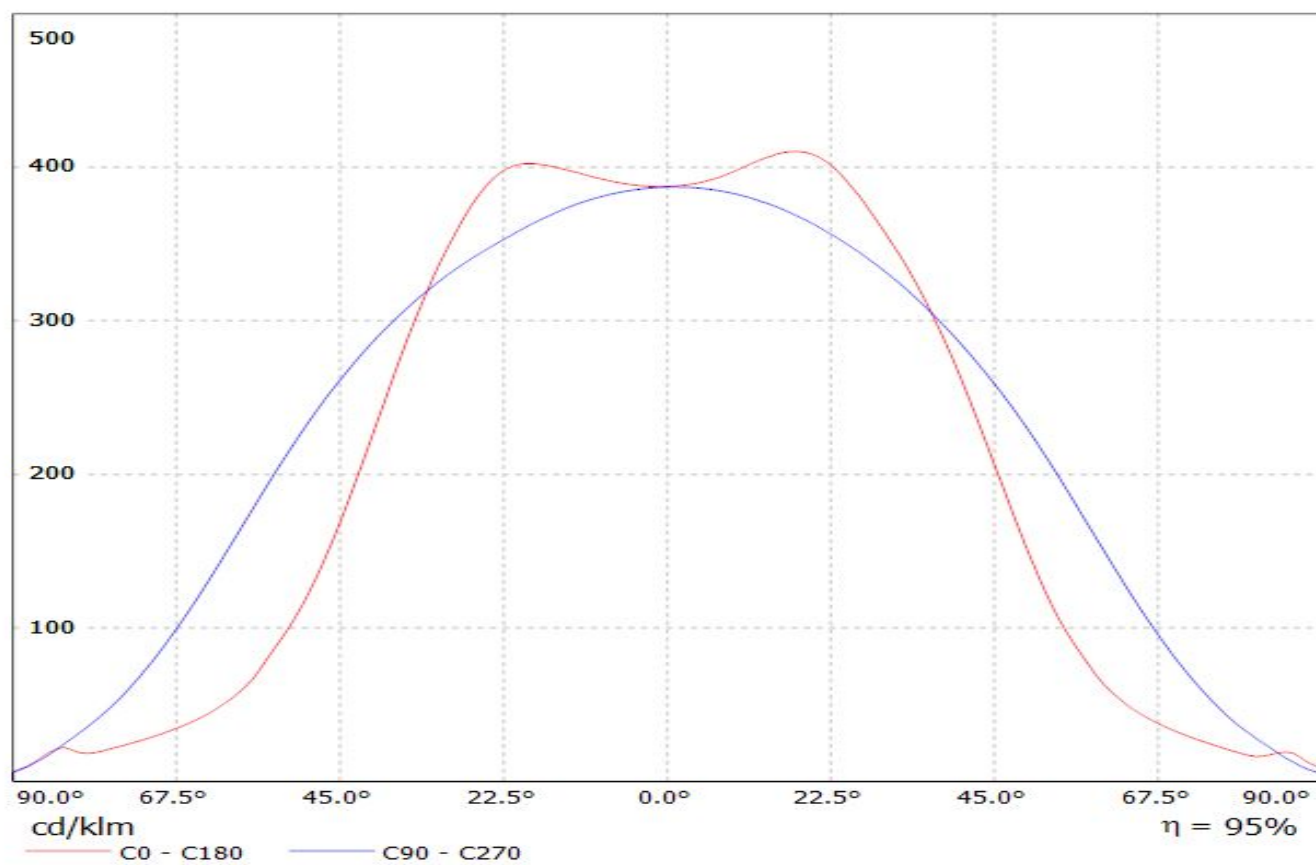

Ledil F14304_FLORENCE-1R-Z90_(LM561B) / LDC (Linear)

Luminaire: Ledil F14304_FLORENCE-1R-Z90_(LM561B)

Lamps: 1 x Samsung_LM561B_x22_348.84lm@65mA_P=1.97W_I=65mA

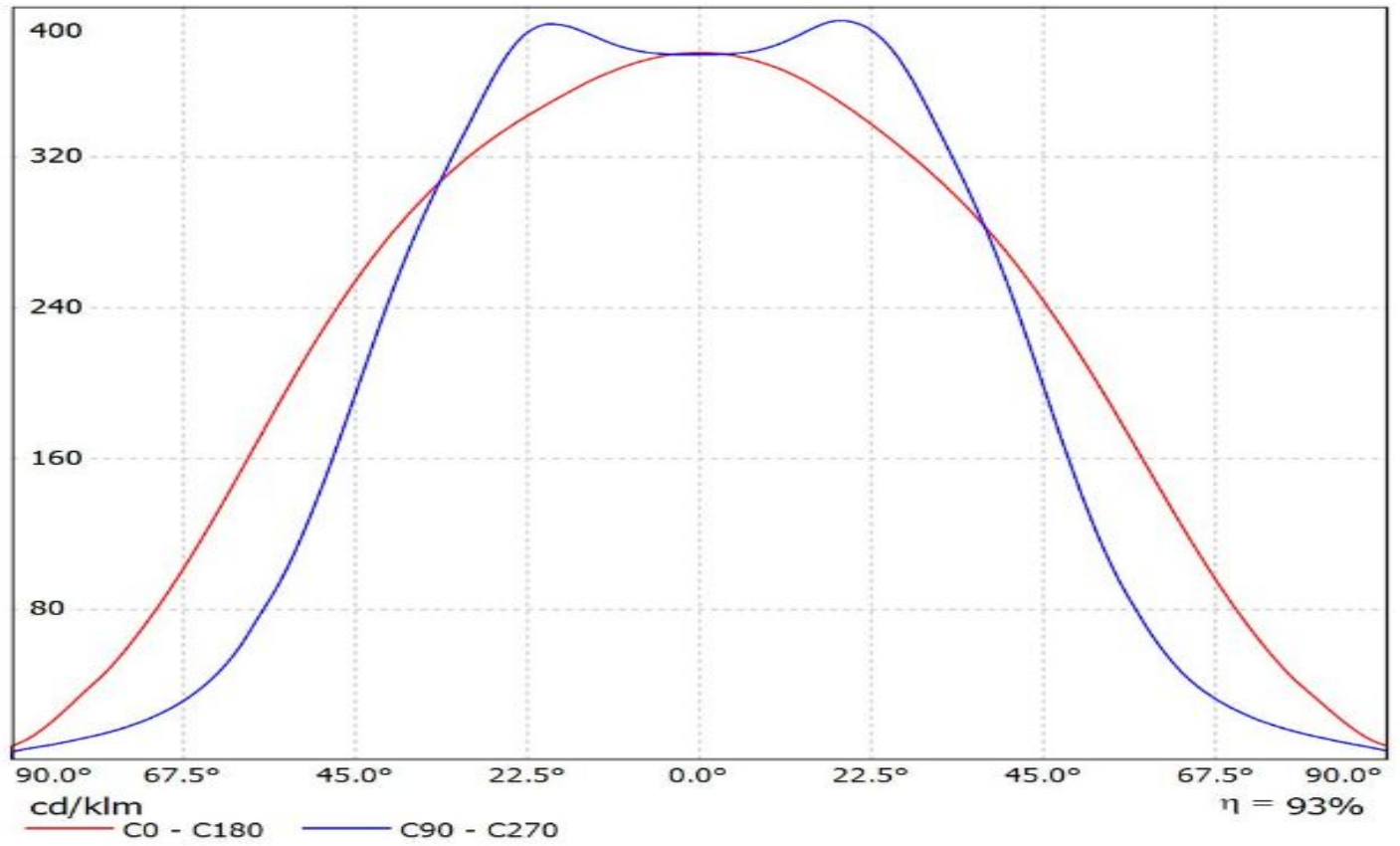

Ledil F14304_FLORENCE-1R-Z90_(Luxeon_3535_2D) / LDC (Linear)

Luminaire: Ledil F14304_FLORENCE-1R-Z90_(Luxeon_3535_2D)

Lamps: 1 x Luxeon_3535_2D_x22_(MXC8_4000K)_910.245lm@100mA_CCT=4000K_P=6.32W_I=0.1A

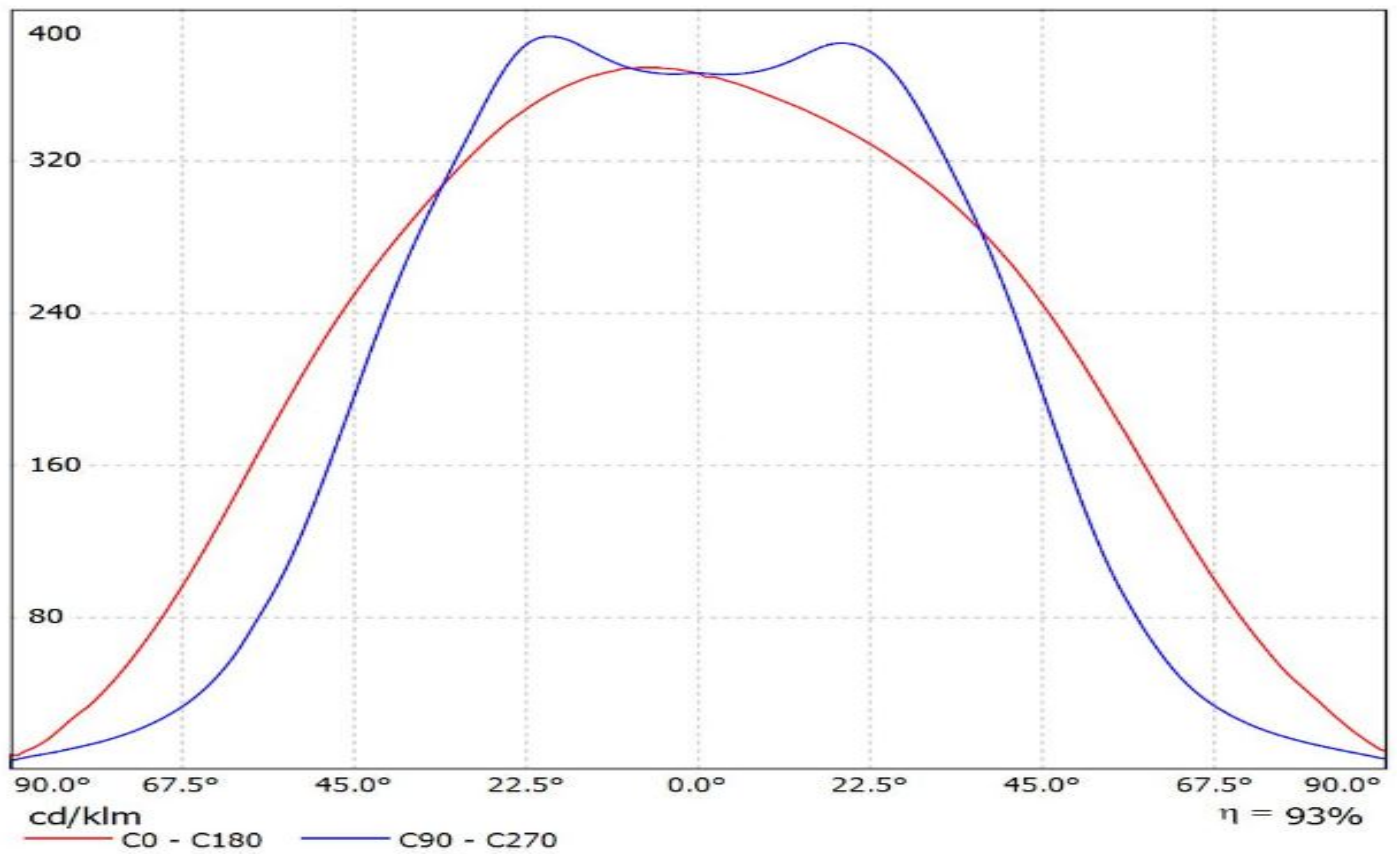

Ledil F14304_FLORENCE-1R-Z90_(XH-B) / LDC (Linear)

Luminaire: Ledil F14304_FLORENCE-1R-Z90_(XH-B)

Lamps: 1 x Cree_XH-B_x22_(XHBAAWT-0-7B4-J20-0H-0001)_315.848lm@65mA_P=2.11W_I=65mA

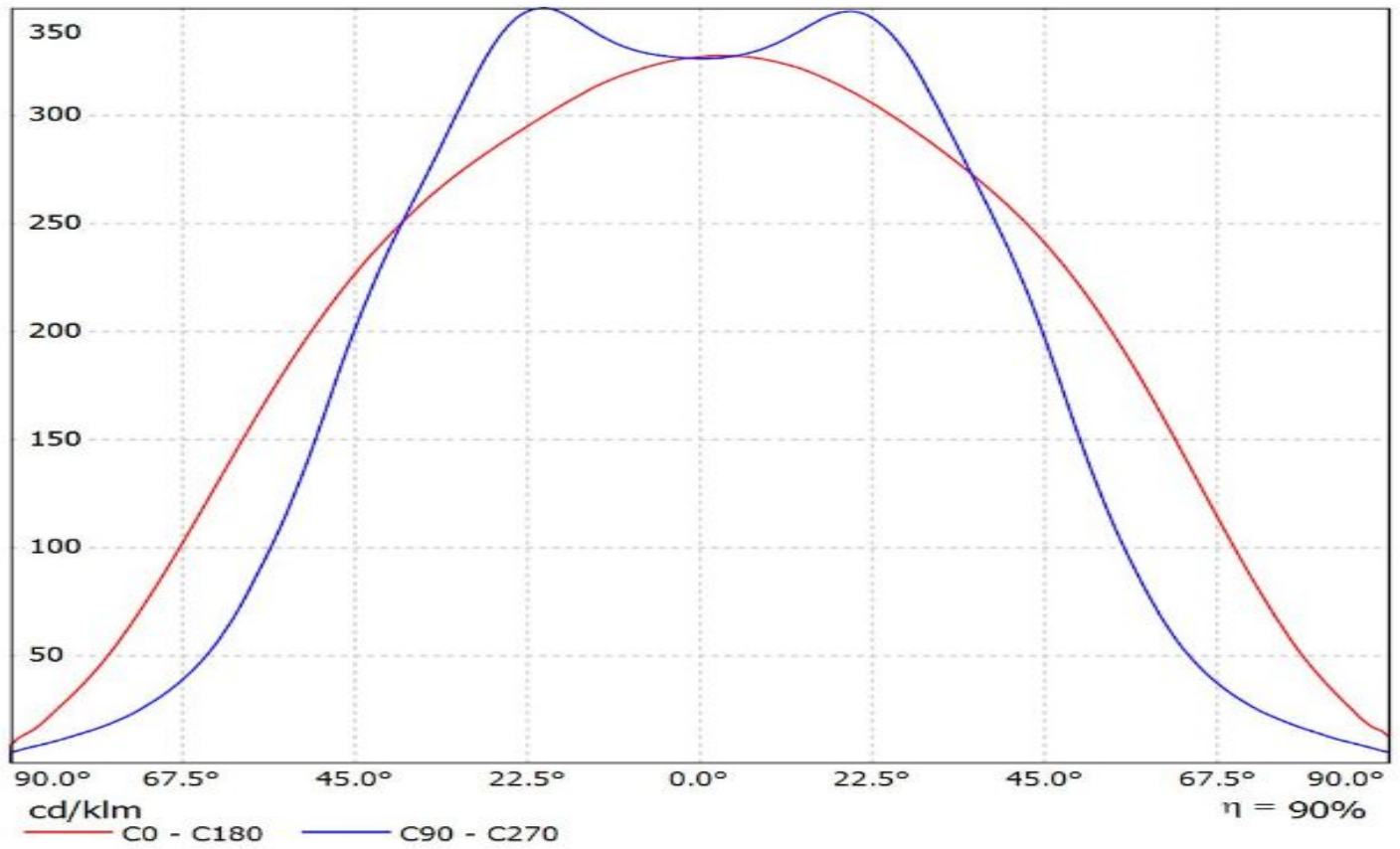

Ledil F14304_FLORENCE-1R-Z90_(Luxeon_3030_2D) / LDC (Polar)

Luminaire: Ledil F14304_FLORENCE-1R-Z90_(Luxeon_3030_2D)

Lamps: 1 x Luxeon_3030_2D_x22_(L130-4080003000W21)

_1601.44lm@200mA_CCT=4000K_P=12.8W_I=0.2A

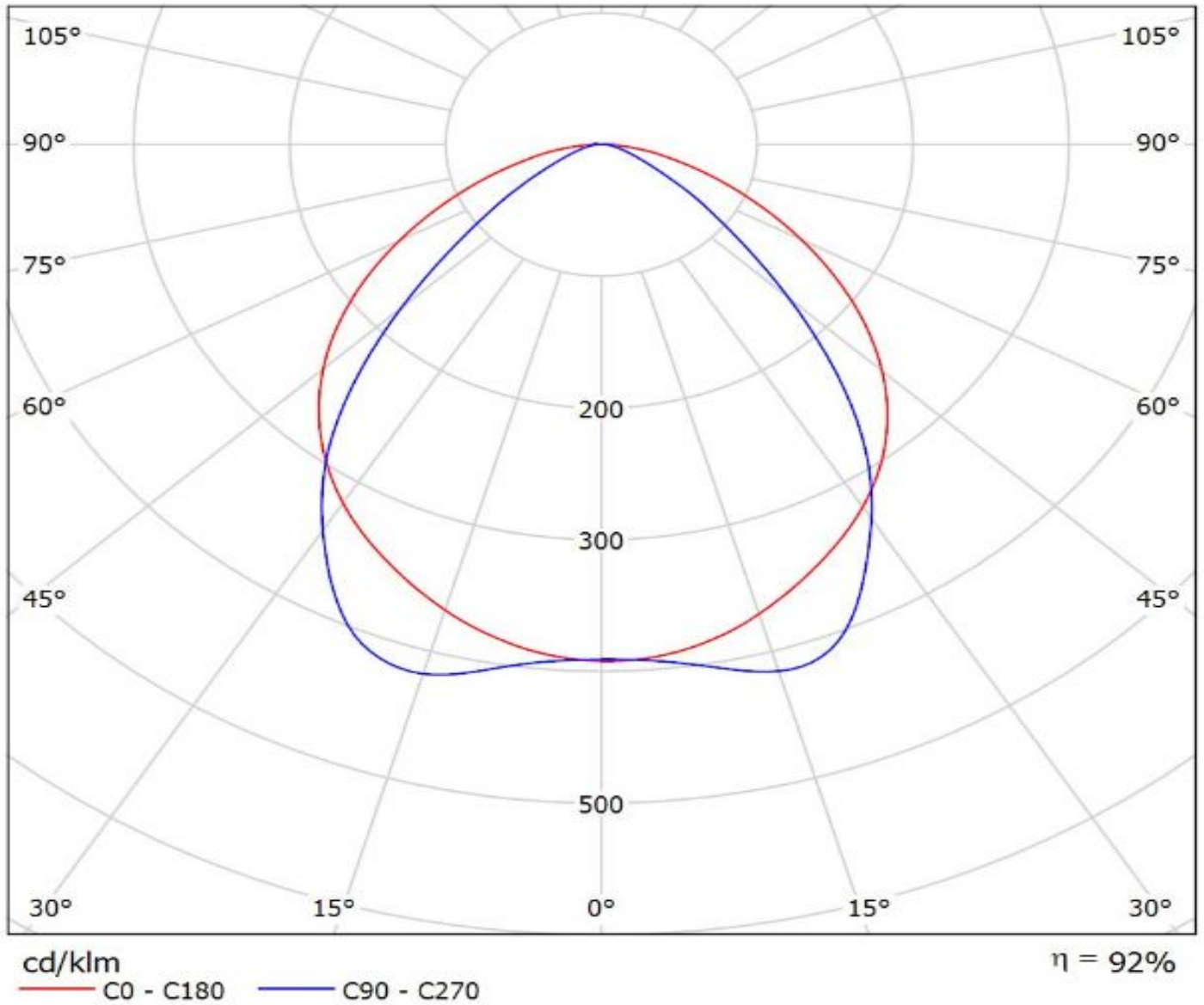

Ledil F14304_FLORENCE-1R-Z90_(Luminus_MP-2016) / LDC (Polar)

Luminaire: Ledil F14304_FLORENCE-1R-Z90_(Luminus_MP-2016)

Lamps: 1 x Luminus_MP-2016_1x22_(LUMMP-1100-30-80)_471.904lm@120mA_P=4W_η=0.12A

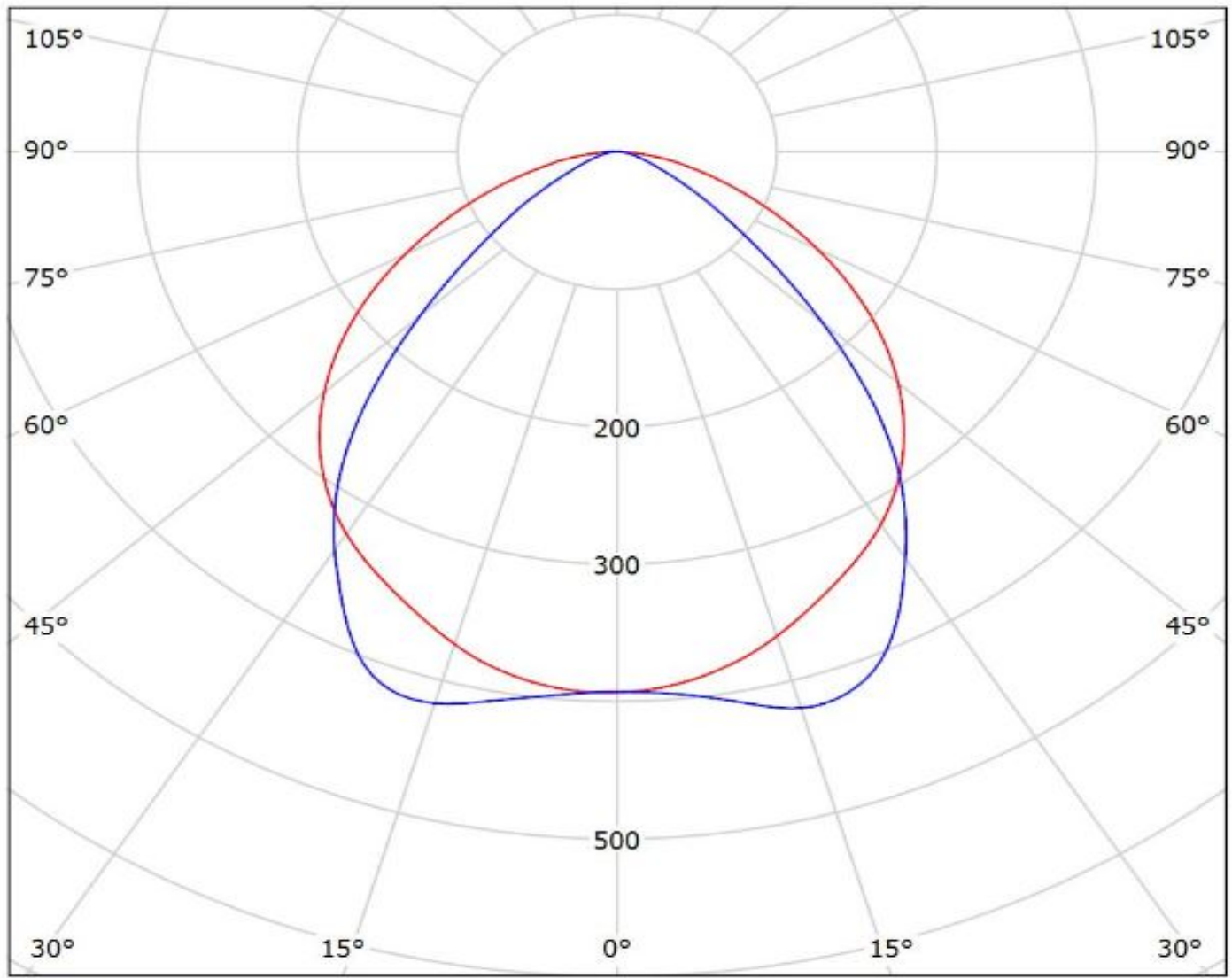

cd/klm

— C0 - C180

— C90 - C270

$\eta = 93\%$

Luminaire: Ledil F14304_FLORENCE-1R-Z90_(Duris_S5)

Lamps: 1 x Osram_Duris_S5_(GW_PSLRS1.EC-LQLS-5H7I-1)_993.467lm@100mA_P=8W_I=0.1000A

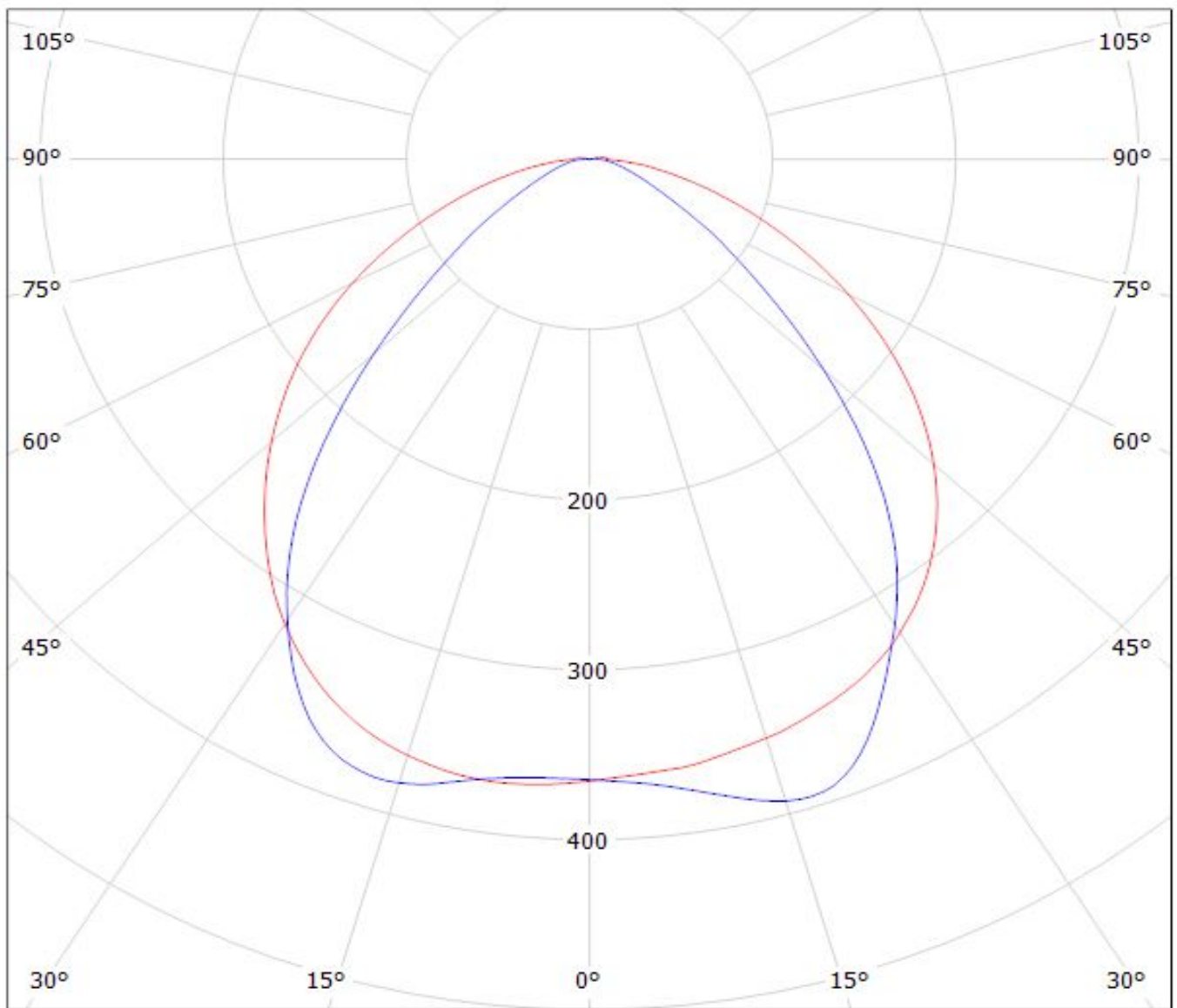

cd/klm

— C0 - C180 — C90 - C270

$\eta = 94\%$

Ledil F14304_FLORENCE-1R-Z90_(NF2x757D) / LDC (Polar)

Luminaire: Ledil F14304_FLORENCE-1R-Z90_(NF2x757D)

Lamps: 1 x Nichia_NF2x757D_2chip_x22 (NF2W757DRT)_2050.61lm@200mA_P=12.95W_I=0.2A

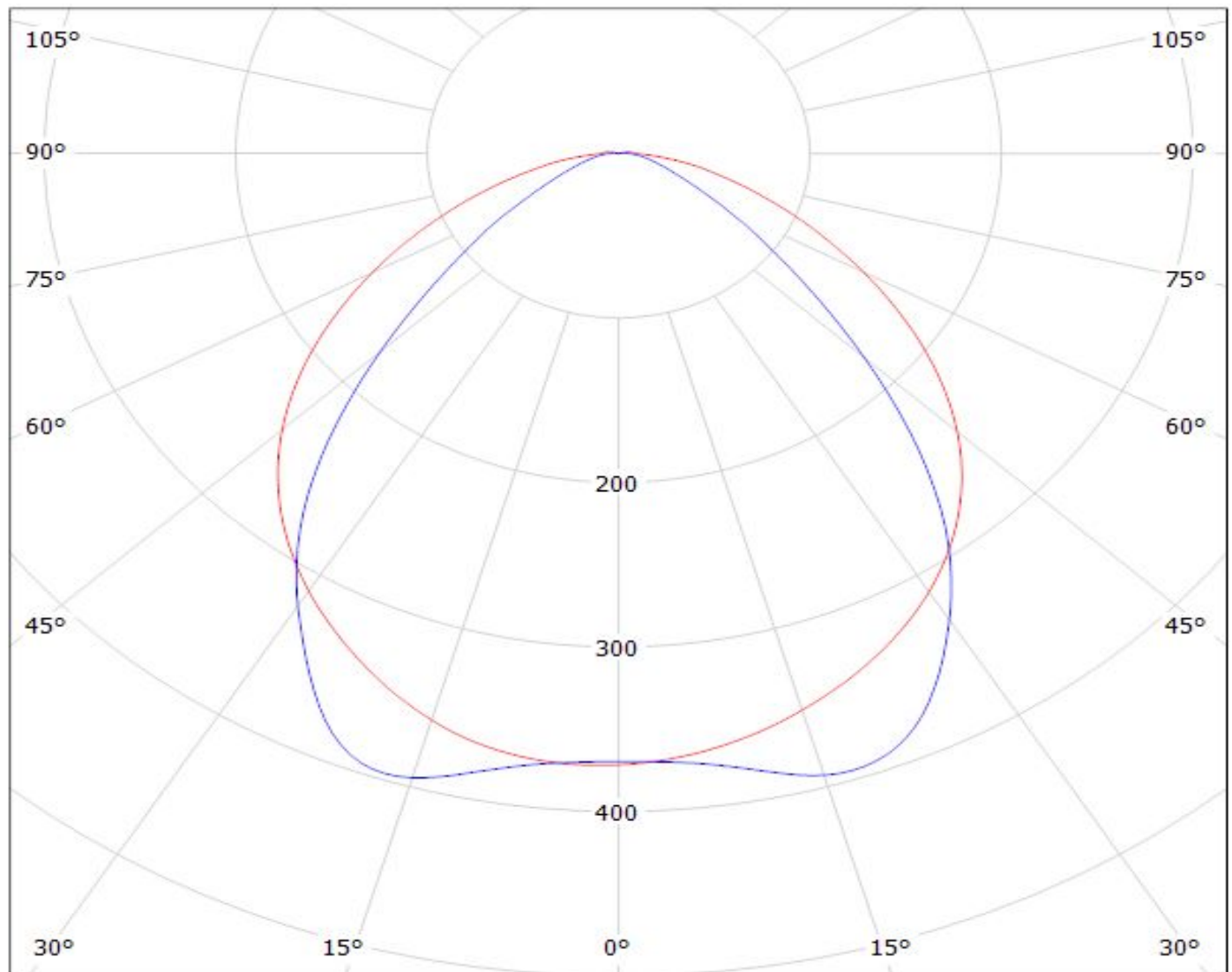

cd/klm

— C0 - C180

— C90 - C270

$\eta = 93\%$

Luminaire: LEDiL Oy F14304_FLORENCE-1R-Z90_(LM302A)

Lamps: 1 x Samsung_LM302A_865.46lm@100mA_P=6.64694W_I=0.1001A

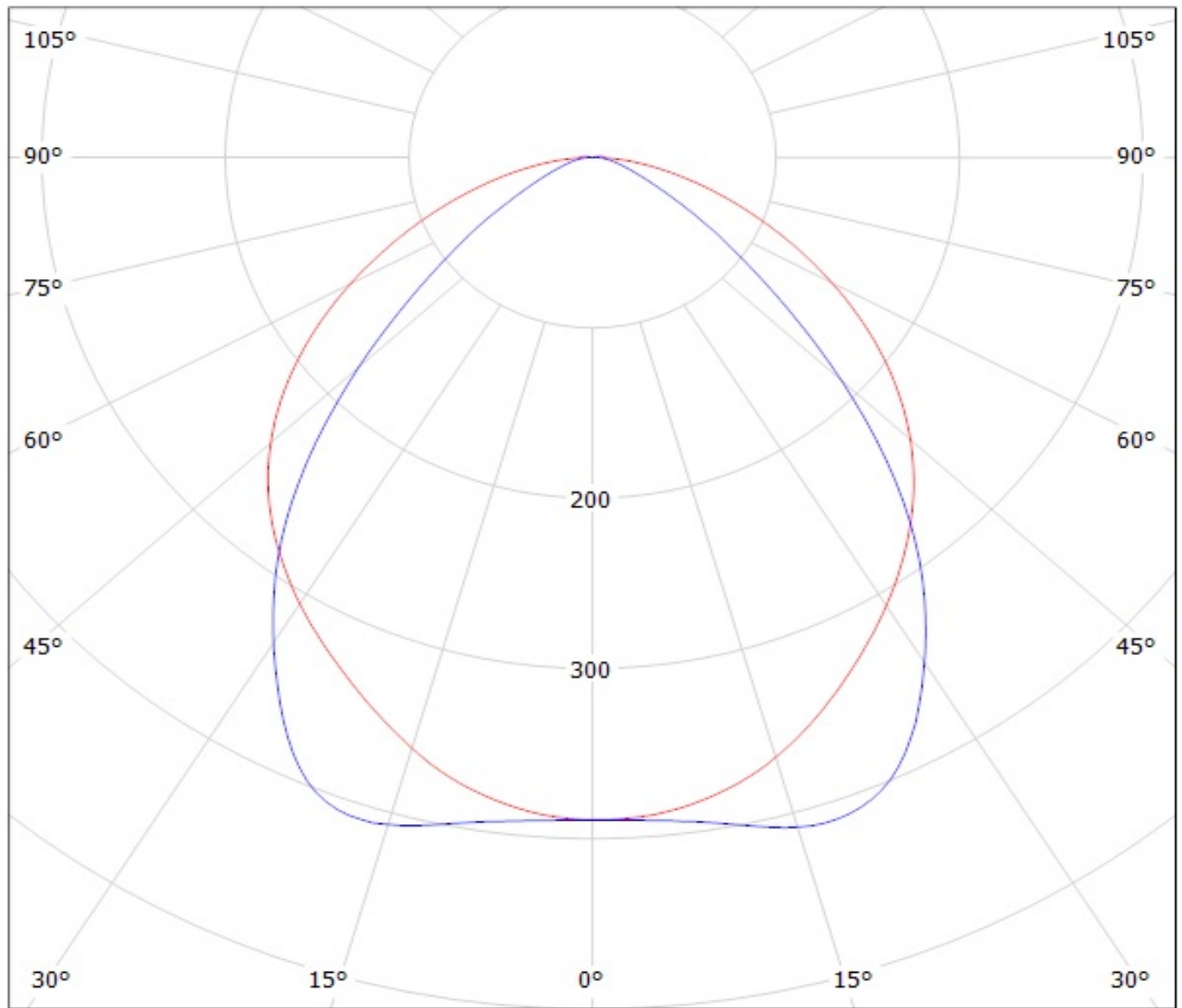

cd/klm

— C0 - C180

— C90 - C270

$\eta = 93\%$

Ledil F14304_FLORENCE-1R-Z90_(Seoul_3030) / LDC (Polar)

Luminaire: Ledil F14304_FLORENCE-1R-Z90_(Seoul_3030)

Lamps: 1 x Seoul_3030_x11_(STW8C2SA)_785.296lm@100mA_P=6.5W_I=0.1A

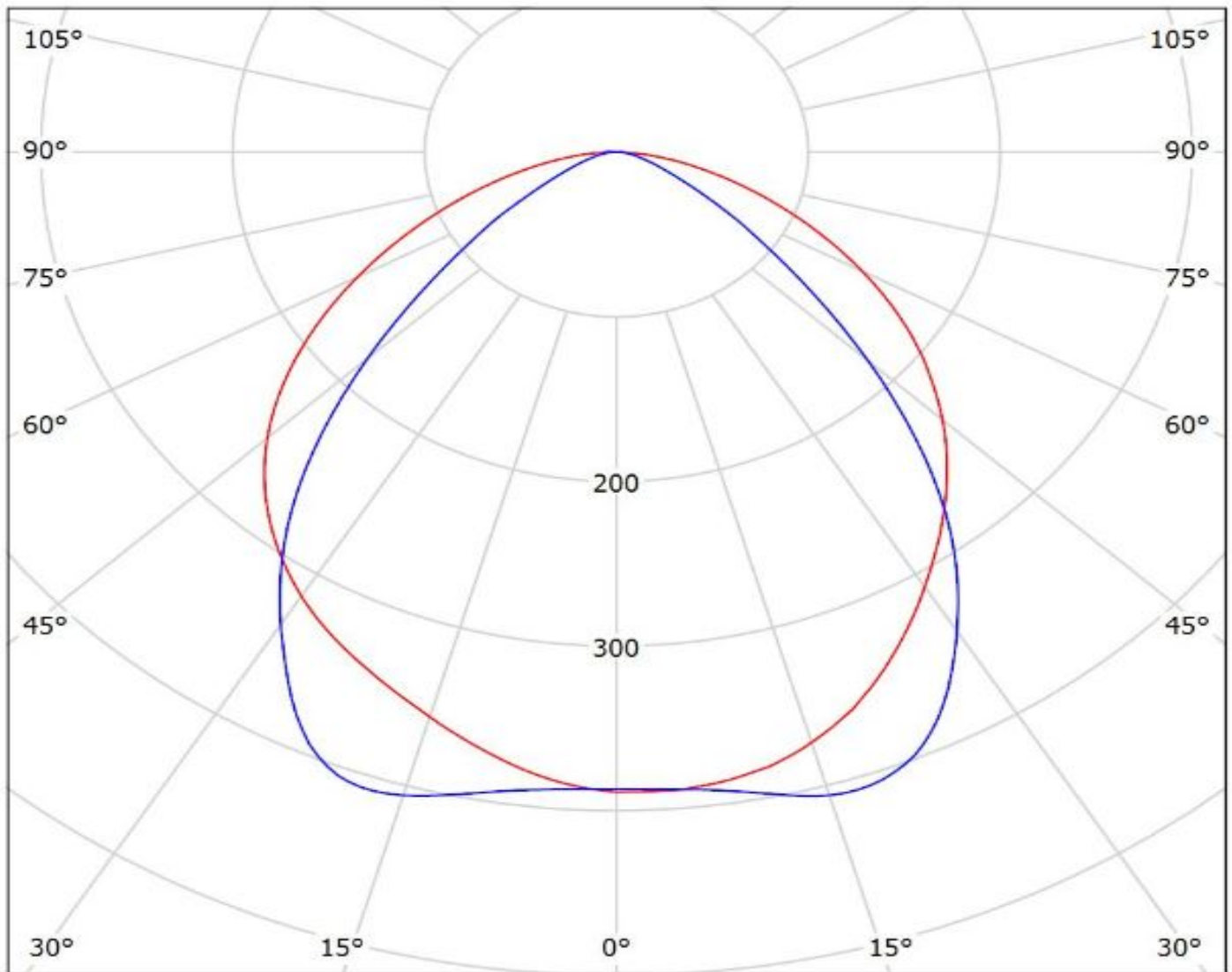

cd/klm

— C0 - C180 — C90 - C270

$\eta = 92\%$

Luminaire: LEDiL Oy F14304_FLORENCE-1R-Z90

Lamps: 1 x Fortimo LED Line 1ft 1100lm 1R_1033.71lm@250mA_P=8.41851W_I=249.8mA

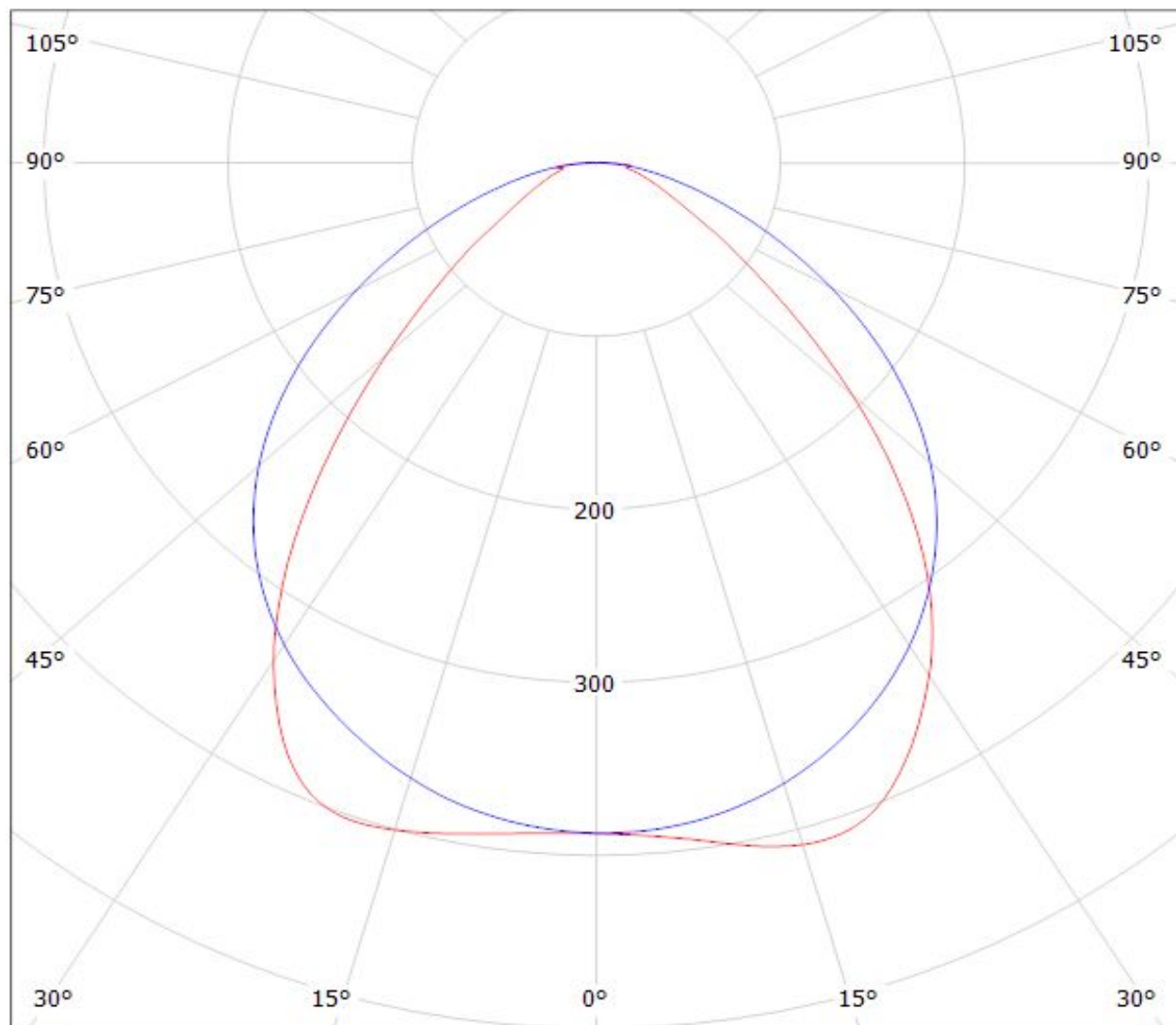

cd/klm

— C0 - C180

— C90 - C270

$\eta = 95\%$

Ledil F14304_FLORENCE-1R-Z90_(LM561B) / LDC (Polar)

Luminaire: Ledil F14304_FLORENCE-1R-Z90_(LM561B)

Lamps: 1 x Samsung_LM561B_x22_348.84lm@65mA_P=1.97W_I=65mA

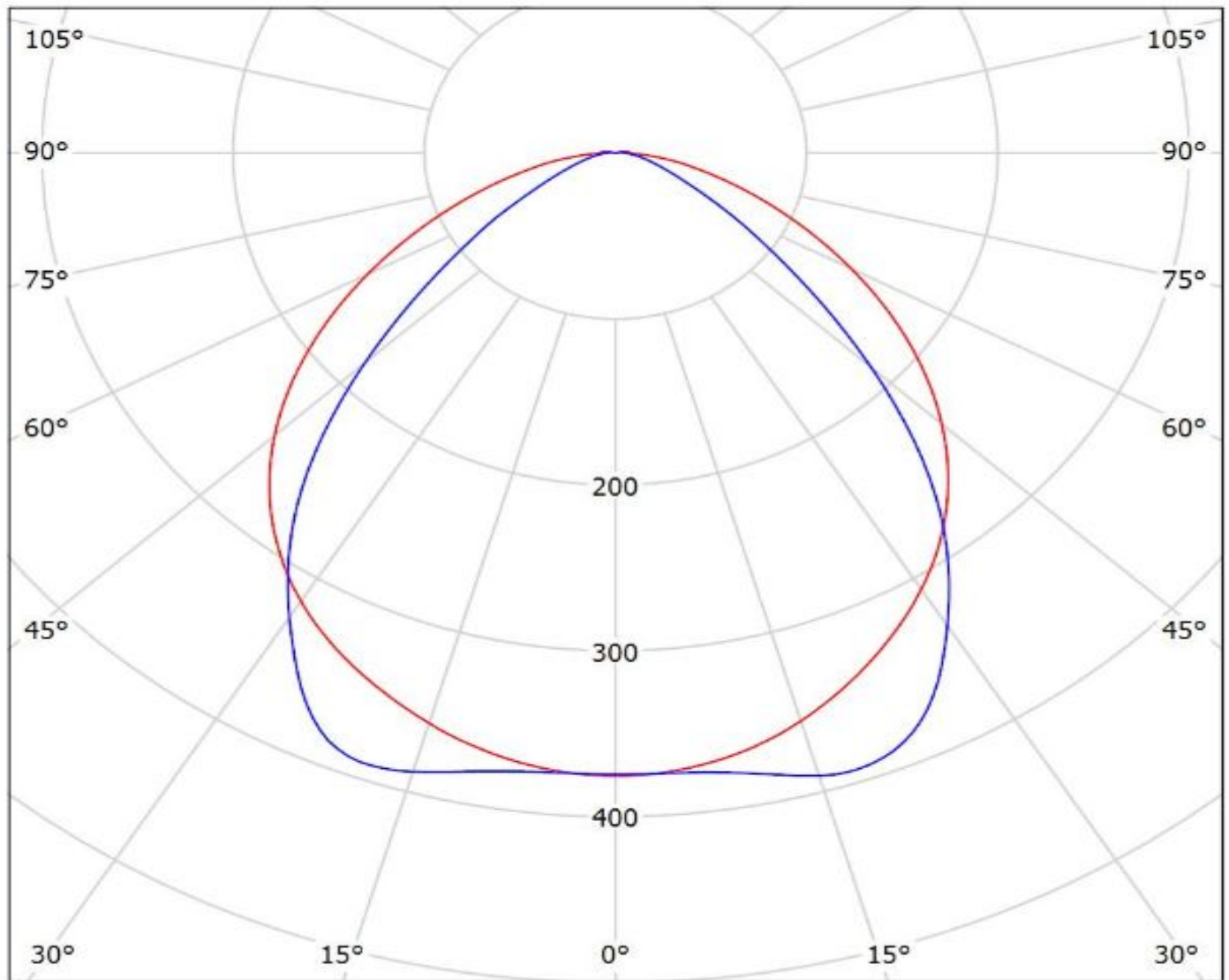

cd/klm

— C0 - C180 — C90 - C270

$\eta = 93\%$

Ledil F14304_FLORENCE-1R-Z90_(Luxeon_3535_2D) / LDC (Polar)

Luminaire: Ledil F14304_FLORENCE-1R-Z90_(Luxeon_3535_2D)

Lamps: 1 x Luxeon_3535_2D_x22_(MXC8_4000K)_910.245lm@100mA_CCT=4000K_P=6.32W_I=0.1A

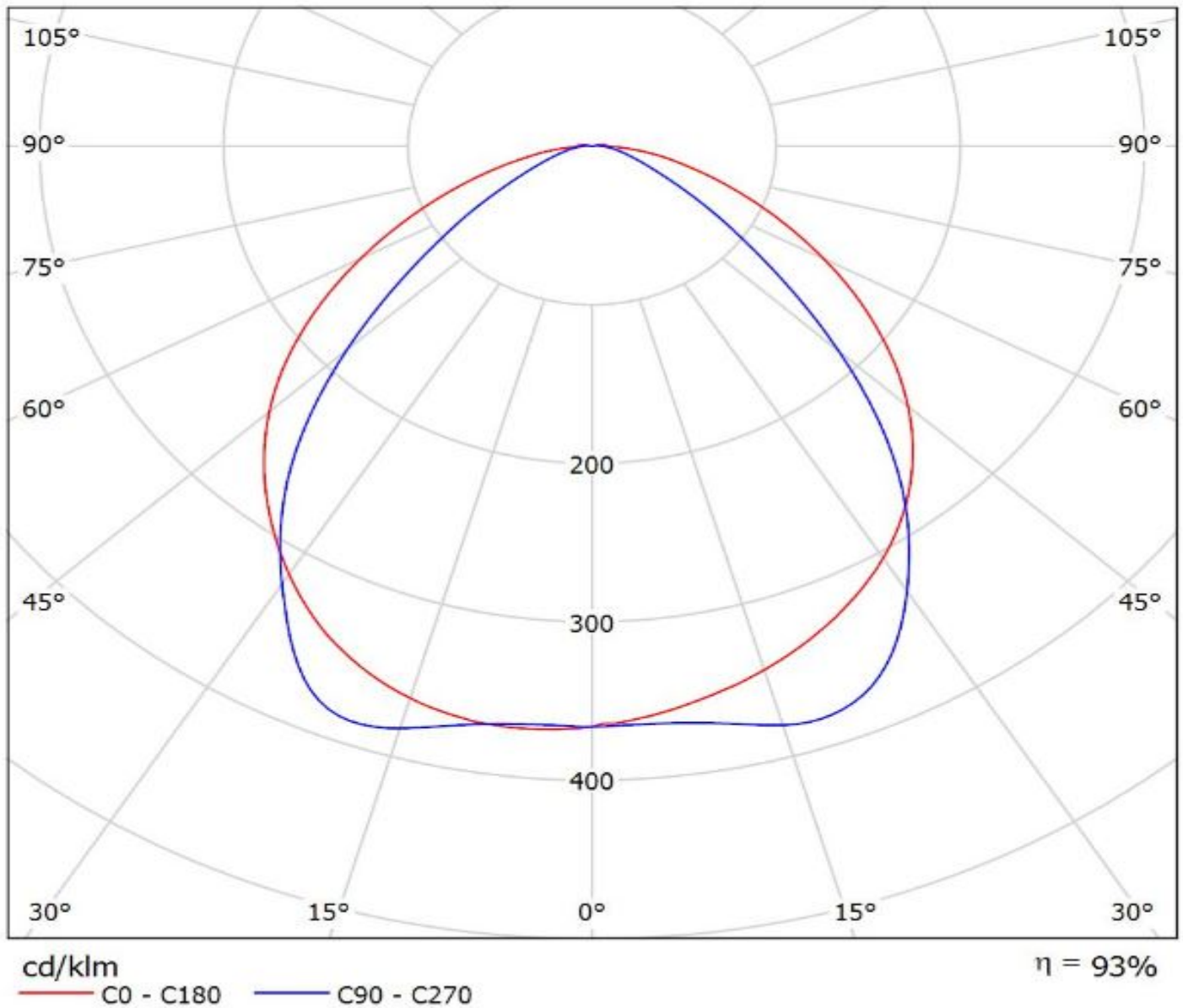

Ledil F14304_FLORENCE-1R-Z90_(XH-B) / LDC (Polar)

Luminaire: Ledil F14304_FLORENCE-1R-Z90_(XH-B)

Lamps: 1 x Cree_XH-B_x22_(XHBAAWT-0-7B4-J20-0H-0001)_315.848lm@65mA_P=2.11W_I=65mA

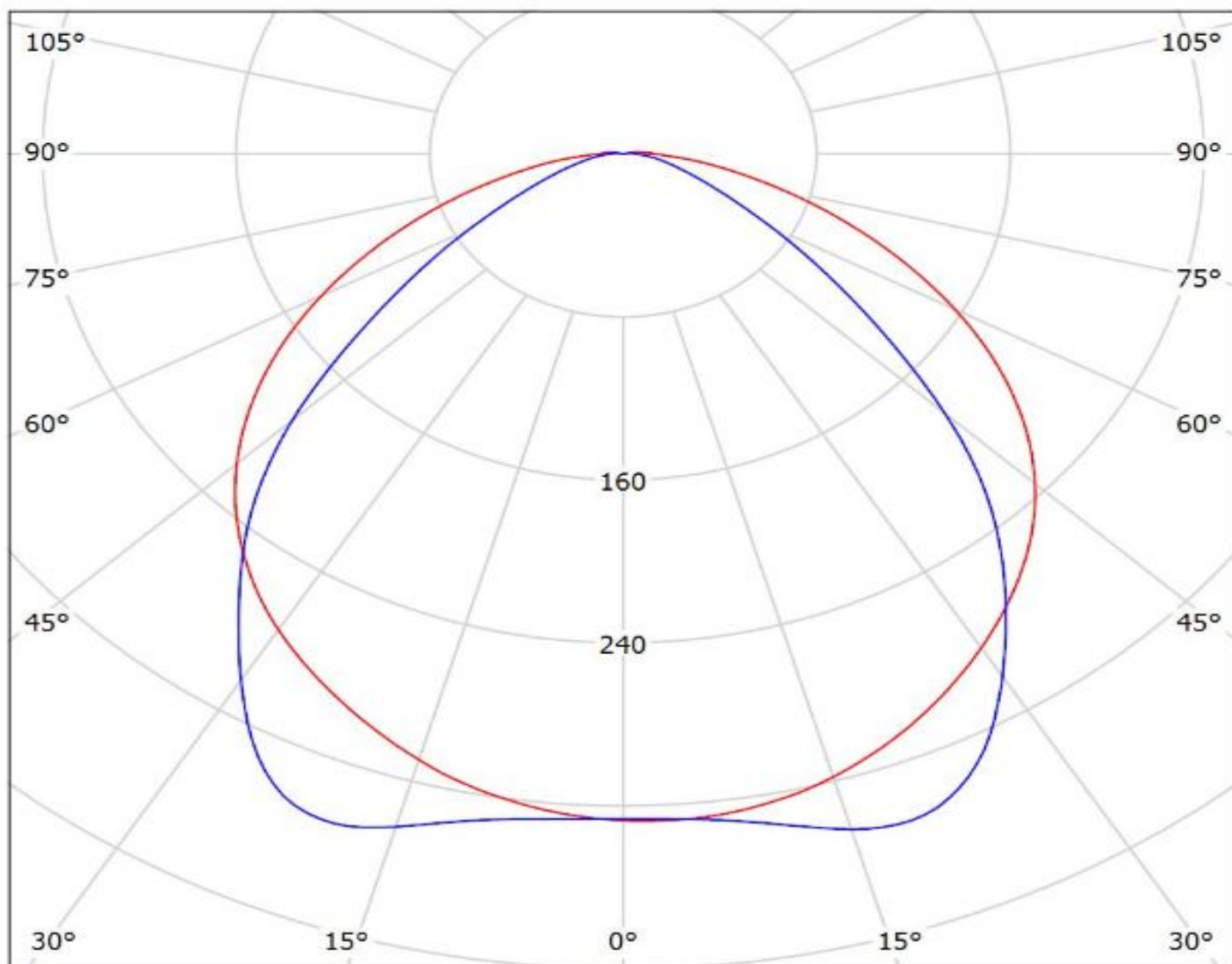

cd/klm

— C0 - C180 — C90 - C270

$\eta = 90\%$

NOTE: The typical divergence will be changed by different color, chip size and chip position tolerance. The typical total divergence is the full angle measured where the luminous intensity is half of the peak value.

GENERAL INFORMATION

- Product series especially designed & optimized for series of LEDs.
- Special care taken to make light distribution as uniform as possible.
- Fastening to PCB with appropriate adhesive. By clicking link below you can find Ledil recommended glue options.
http://www.ledil.com/datasheets/DataSheet_GLUES.pdf

NOTE 1: We advise customer to ensure the suitability and sufficiency of the bond in the end product. For example, mechanical stress, vibration and holes on the surface of the circuit board weaken the strength of the glue.

NOTE 2: All surfaces where glue is applied must be clean, dry and free from grease and dirt. If cleaning of PCB surfaces is needed, please follow strictly the cleaning instructions of your LED manufacturer -this is important as cleaning shall under no circumstances damage LEDs or other electronics components on the PCB.

Further note that optical components shall not be cleaned with any chemicals - only micro fiber cloth may be used to remove fingerprints or other traces from handling.