

22MM METAL ROUND ACTUATOR: EMERGEN.-STOP  
MUSHR.PUSHB. 40MM LATCHING W.PULL-TO-UNLOCK MECH.  
WITH HOLDER RED, SOLVENT-RESISTANT



<b>Design of the product</b>	Single device round with positive latching in accordance with ISO 13850
<b>Enclosure:</b>	
Number of command points	1
<b>Actuator:</b>	
Design of the operating mechanism	Emergency stop mushroom pushbutton
Manner of function of the actuating element	Latching
Product expansion optional Light source	No
Color	
• of the actuating element	Red
Material of the actuating element	plastic
Outer diameter of the actuating element	40 mm
Type of unlocking device	pull-to-unlatch mechanism
Number of switching positions	2
<b>Front ring:</b>	
Product component front ring	No
<b>Holder:</b>	
Material of the holder	Metal

**General technical data:**

<b>Product function</b>	
• EMERGENCY OFF function	Yes
• EMERGENCY STOP function	Yes
<b>Vibration resistance</b>	
• acc. to IEC 60068-2-6	20 ... 200 Hz: 5g
<b>Operating frequency maximum</b>	1 000 1/h
<b>Mechanical service life (switching cycles)</b>	
• typical	300 000
<b>Protection class IP</b>	IP67
<b>Equipment marking</b>	
• acc. to DIN 40719 extended according to IEC 204-2 acc. to IEC 750	S
• acc. to DIN EN 61346-2	S
• acc. to DIN EN 81346-2	S

**Safety related data:**

<b>B10 value with high demand rate acc. to SN 31920</b>	30 000
<b>Proportion of dangerous failures</b>	
• with low demand rate acc. to SN 31920	20 %
• with high demand rate acc. to SN 31920	20 %
<b>T1 value for proof test interval or service life acc. to IEC 61508</b>	20 y

**Ambient conditions:**

<b>Ambient temperature</b>	
• during operation	-25 ... +70 °C
• during storage	-40 ... +80 °C
<b>Environmental category during operation acc. to IEC 60721</b>	3K6

**Installation/ mounting/ dimensions:**

<b>Mounting type</b>	front mounting
<b>Shape of the installation opening</b>	round
<b>Mounting diameter</b>	22 mm

**Certificates/ approvals:**

General Product Approval	Functional Safety/Safety of Machinery	Declaration of Conformity	Test Certificates
--------------------------	---------------------------------------	---------------------------	-------------------



[spezielle Prüfbescheinigung](#)  
[n](#)

Shipping Approval	other
-------------------	-------



[Bestätigungen](#)

other
-------

[Umweltbestätigung](#)

[sonstige](#)

### Further information

**Information- and Downloadcenter (Catalogs, Brochures,...)**

<http://www.siemens.com/industrial-controls/catalogs>

**Industry Mall (Online ordering system)**

<http://www.siemens.com/industrymall>

**Cax online generator**

<http://support.automation.siemens.com/WW/CAXorder/default.aspx?lang=en&mfb=3SB35001TA20>

**Service&Support (Manuals, Certificates, Characteristics, FAQs,...)**

<https://support.industry.siemens.com/cs/ww/en/ps/3SB35001TA20>

**Image database (product images, 2D dimension drawings, 3D models, device circuit diagrams, EPLAN macros, ...)**

[http://www.automation.siemens.com/bilddb/cax\\_de.aspx?mfb=3SB35001TA20&lang=en](http://www.automation.siemens.com/bilddb/cax_de.aspx?mfb=3SB35001TA20&lang=en)

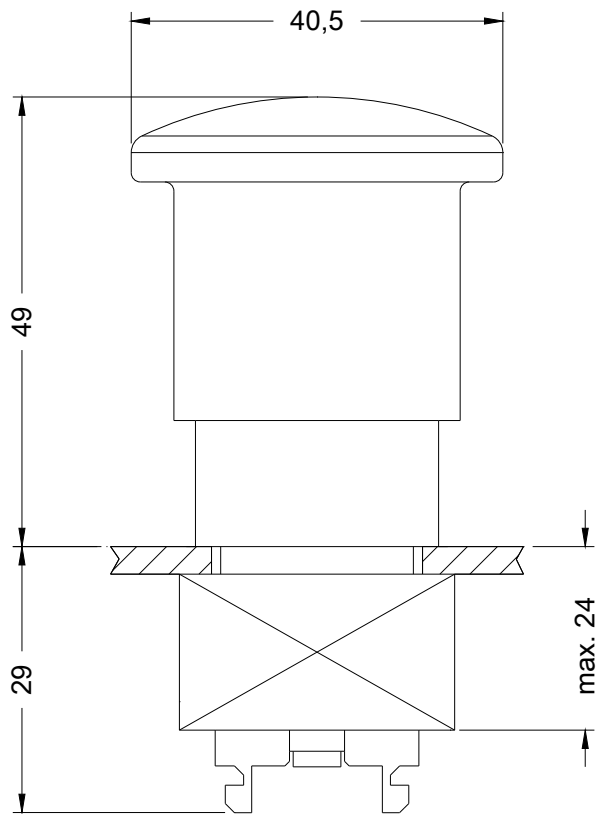

last modified:

27.07.2015