



MBRS20H100CT - MBR20H200CT

20.0AMPS. Surface Mount Schottky Barrier Rectifiers

D²PAK

Features

- ✧ UL Recognized File # E-326854
- ✧ Plastic material used carriers Underwriters Laboratory Classification 94V-0
- ✧ Metal silicon junction, majority carrier conduction
- ✧ Low power loss, high efficiency
- ✧ High current capability, low forward voltage drop
- ✧ High surge capability
- ✧ For use in power supply - output rectification, power management, instrumentation
- ✧ Guard-ring for overvoltage protection
- ✧ High temperature soldering guaranteed: 260°C/10 seconds/.25", (6.35mm) from case
- ✧ Green compound with suffix "G" on packing code & prefix "G" on datecode

Mechanical Data

- ✧ Case: D²PAK molded plastic body
- ✧ Terminals: Pure tin plated, lead free, solderable per MIL-STD-750, Method 2026
- ✧ Polarity: As marked
- ✧ Mounting position: Any
- ✧ Mounting torque: 5 in. - lbs, max
- ✧ Weight: 1.41 grams

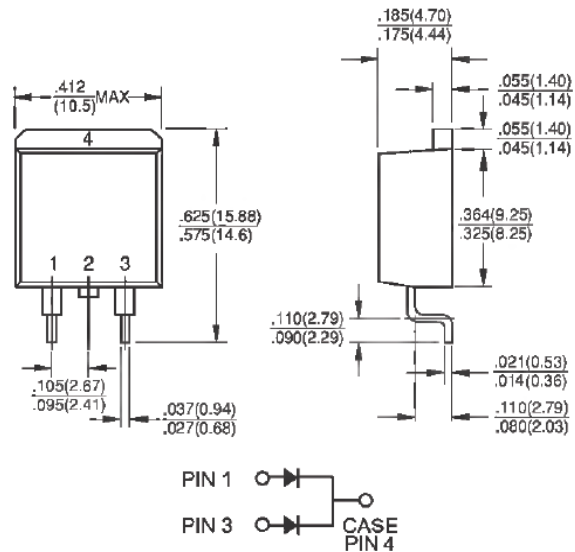

Dimensions in inches and (millimeters)

Marking Diagram



- MBR20HXXCT = Specific Device Code
- G = Green Compound
- Y = Year
- WW = Work Week

Maximum Ratings and Electrical Characteristics

Rating at 25 °C ambient temperature unless otherwise specified.

Single phase, half wave, 60 Hz, resistive or inductive load.

For capacitive load, derate current by 20%

Type Number	Symbol	MBRS 20H100CT	MBRS 20H150CT	MBRS 20H200CT	Unit
Maximum Repetitive Peak Reverse Voltage	V_{RRM}	100	150	200	V
Maximum RMS Voltage	V_{RMS}	70	105	140	V
Maximum DC Blocking Voltage	V_{DC}	100	150	200	V
Maximum Average Forward Rectified Current at $T_C=125^\circ C$	$I_{F(AV)}$	20			A
Peak Repetitive Surge Current (Rated V_R , Square Wave, 20KHz) at $T_C=125^\circ C$	I_{FRM}	20			A
Peak Forward Surge Current, 8.3 ms Single Half Sine-wave Superimposed on Rated Load (JEDEC method)	I_{FSM}	150			A
Peak Repetitive Reverse Surge Current (Note 1)	I_{RRM}	1		0.5	A
Maximum Instantaneous Forward Voltage (Note 2) $I_F=10A, T_A=25^\circ C$ $I_F=10A, T_A=125^\circ C$ $I_F=20A, T_A=25^\circ C$ $I_F=20A, T_A=125^\circ C$	V_F	0.85 0.75 0.95 0.85	0.88 0.75 0.97 0.85		V
Maximum Reverse Current @ Rated V_R $T_A=25^\circ C$ $T_A=125^\circ C$	I_R	5 2			 mA
Voltage Rate of Change, (Rated V_R)	dV/dt	10000			V/us
Typical Thermal Resistance (Note 3)	$R_{\theta JC}$	1.5			$^\circ C/W$
Operating Temperature Range	T_J	- 65 to + 175			$^\circ C$
Storage Temperature Range	T_{STG}	- 65 to + 175			$^\circ C$

Note 1: 2.0uS Pulse Width, f=1.0KHz

Note 2: Pulse Test : 300uS Pulse Width, 1% Duty Cycle

Note 3: Mount on Heatsink Size of 2in x 3in x 0.25in Al-Plate

RATINGS AND CHARACTERISTIC CURVES (MBRS20H100CT THRU MBRS20H200CT)

FIG. 1 FORWARD CURRENT DERATING CURVE

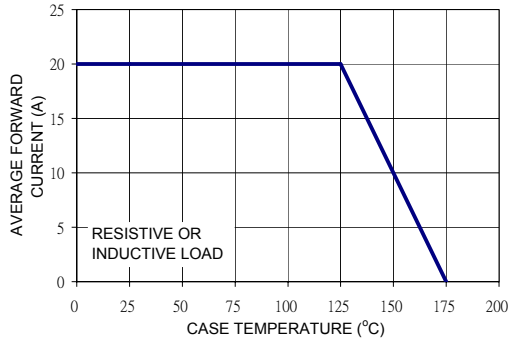

FIG. 2 MAXIMUM NON-REPETITIVE FORWARD SURGE CURRENT PER LEG

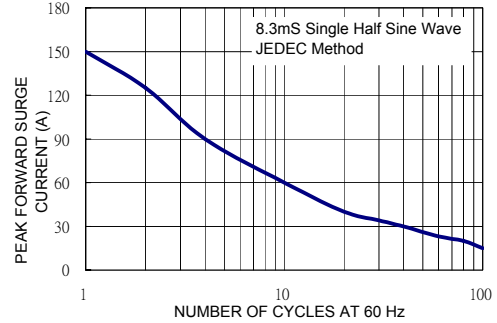

FIG. 3 TYPICAL FORWARD CHARACTERISTICS PER LEG

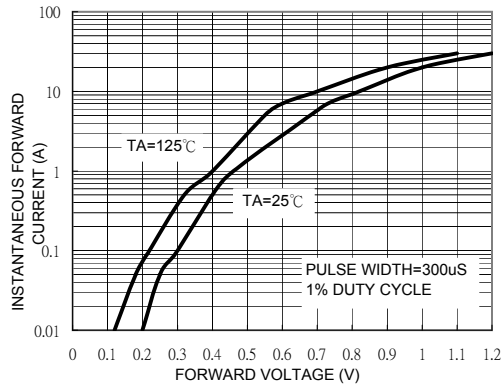

FIG. 4 TYPICAL REVERSE CHARACTERISTICS PER LEG

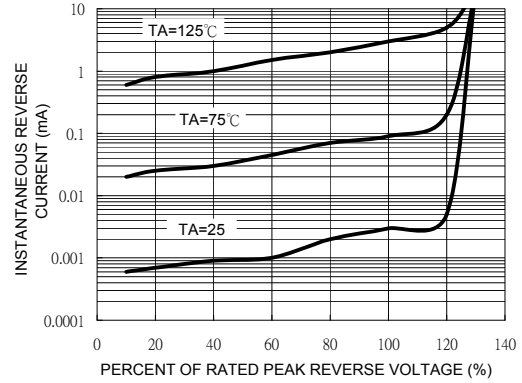

FIG. 5 TYPICAL JUNCTION CAPACITANCE

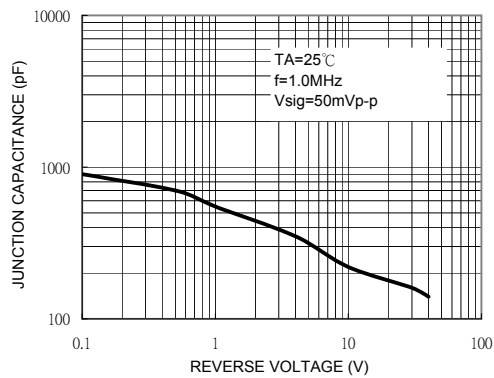

FIG. 6 TYPICAL TRANSIENT THERMAL IMPEDANCE PER LEG

