



HB34, HF34 and HG34 Varistor Series



Agency Approvals

| Agency | Agency Approval | Agency File Number |
|---|-----------------|--------------------|
|  | UL1449 | E320116 |
|  | 22.2-1 | 91788 |

Additional Information



Datasheet



Resources



Samples

Description

The HB34, HF34, and HG34 Series of transient surge suppressors are industrial high-energy Metal-Oxide Varistors (MOVs). They are designed to provide surge suppression in the AC mains outdoor and service entrance environment (distribution panels) of buildings. Applications also include industrial heavy motors, controls, and power supplies such as used in the oil-drilling, mining, and transportation fields, including HVAC and motor/generator applications.

The HB34 Series provides rigid terminals for through-hole solder mounting on printed circuit boards, thereby eliminating the need for screw mounting. The HF34 Series has the same rigid through-hole terminals as the HB34 with the addition of mounting holes for bolt-down mounting and longer terminals to allow for additional mounting flexibility. The HG34 has formed feet with mounting holes for vertical bolt-down mounting.

See Ratings and Specifications table for part numbers.

Features

- Lead-Free, Halogen-Free and RoHS Compliant available
- High peak pulse current capability
 $I_{TM} = 40,000A$
- Wide operating voltage range
 $V_{MIACIRMS} = 110V$ to 750V
- Rigid terminals for secure through-hole solder mounting
- High energy absorption capability
 $W_{TM} = 220J$ to 1050J
- No derating up to 85°C ambient

Absolute Maximum Ratings

• For ratings of individual members of a series, see Device Ratings and Specifications chart

| Continuous | Hx34 Series | Units |
|---|-------------|------------|
| Steady State Applied Voltage: | | |
| AC Voltage Range ($V_{MIACIRMS}$) | 110 to 750 | V |
| DC Voltage Range (V_{MIDC}) | 148 to 970 | V |
| Transients: | | |
| Peak Pulse Current (I_{TM}) For 8/20 μs Current Wave (See Figure 2) | 40000 | A |
| Single Pulse Energy Range For 2ms Current Wave (W_{TM}) | 220 to 1050 | J |
| Operating Ambient Temperature Range (T_A) | -55 to +85 | °C |
| Storage Temperature Range (T_{STG}) | -55 to +125 | °C |
| Temperature Coefficient (a^V) of Clamping Voltage (V_C) at Specified Test Current | <0.01 | %/°C |
| Hi-Pot Encapsulation (COATING Isolation Voltage Capability) (Dielectric must withstand indicated DC voltage for one minute per MILSTD 202, Method 301) | 2500 | V |
| COATING Insulation Resistance | 1000 | M Ω |

CAUTION: Stresses above those listed in "Absolute Maximum Ratings" may cause permanent damage to the device. This is a stress only rating and operation of the device at these or any other conditions above those indicated in the operational sections of this specification is not implied.

HB34 Series Ratings & Specifications

| Lead-free and RoHS Compliant Models | Model Size Disc Dia. (mm) | Maximum Rating (85°C) | | | | Specifications (25°C) | | | | |
|-------------------------------------|---------------------------|-----------------------|-------------|--------------|-------------------------------|---|-------------|-------|---|---------------------|
| | | Continuous | | Transient | | Varistor Voltage at 1mA DC Test Current | | | Maximum Clamping Voltage V_c at 200A Current (8/20 μ s) | Typical Capacitance |
| | | V_{RMS} | V_{DC} | Energy (2ms) | Peak Current (8 x 20 μ s) | | | | | |
| | | $V_{M(AC)}$ | $V_{M(DC)}$ | W_{TM} | I_{TM} | Min | $V_{N(DC)}$ | Max | V_c | $f = 1\text{MHz}$ |
| Part Number | | (V) | (V) | (J) | (A) | (V) | (V) | (V) | (V) | (pF) |
| V111HB34 | 34 | 110 | 148 | 220 | 40,000 ¹ | 156 | 173 | 190 | 288 | 11,600 |
| V131HB34 | 34 | 130 | 175 | 270 | 40,000 ² | 184.5 | 205 | 225.5 | 345 | 10,000 |
| V141HB34 | 34 | 140 | 188 | 291 | 40,000 ³ | 198 | 220 | 242 | 375 | 9,000 |
| V151HB34 | 34 | 150 | 200 | 300 | 40,000 ⁴ | 216 | 240 | 264 | 405 | 8,000 |
| V181HB34 | 34 | 180 | 240 | 330 | 40,000 | 254 | 282 | 310 | 468 | 6,800 |
| V201HB34 | 34 | 200 | 265 | 350 | 40,000 | 283 | 314 | 345 | 533 | 6,350 |
| V251HB34 | 34 | 250 | 330 | 370 | 40,000 | 351 | 390 | 429 | 650 | 5,000 |
| V271HB34 | 34 | 275 | 370 | 400 | 40,000 | 387 | 430 | 473 | 730 | 4,500 |
| V301HB34 | 34 | 300 | 410 | 430 | 40,000 | 423 | 470 | 517 | 780 | 4,100 |
| V321HB34 | 34 | 320 | 420 | 460 | 40,000 | 459 | 510 | 561 | 830 | 3,800 |
| V331HB34 | 34 | 330 | 435 | 475 | 40,000 | 467 | 518.5 | 570 | 843 | 3,750 |
| V351HB34 | 34 | 350 | 460 | 500 | 40,000 | 495 | 549.5 | 604 | 894 | 3,600 |
| V391HB34 | 34 | 385 | 510 | 550 | 40,000 | 545 | 604 | 663 | 1000 | 3,500 |
| V421HB34 | 34 | 420 | 560 | 600 | 40,000 | 612 | 680 | 748 | 1,130 | 3,000 |
| V441HB34 | 34 | 440 | 587 | 620 | 40,000 | 622 | 690 | 758 | 1,150 | 2,900 |
| V481HB34 | 34 | 480 | 640 | 650 | 40,000 | 675 | 750 | 825 | 1,240 | 2,700 |
| V511HB34 | 34 | 510 | 675 | 700 | 40,000 | 738 | 820 | 902 | 1,350 | 2,500 |
| V551HB34 | 34 | 550 | 710 | 755 | 40,000 | 778 | 863.5 | 949 | 1,404 | 2,390 |
| V571HB34 | 34 | 570 | 730 | 770 | 40,000 | 819 | 910 | 1001 | 1,480 | 2,200 |
| V661HB34 | 34 | 660 | 850 | 900 | 40,000 | 945 | 1050 | 1155 | 1,720 | 2,000 |
| V681HB34 | 34 | 680 | 875 | 925 | 40,000 | 962 | 1067.5 | 1173 | 1,777 | 1,900 |
| V751HB34 | 34 | 750 | 970 | 1050 | 40,000 | 1080 | 1200 | 1320 | 2,000 | 1,800 |

NOTE: Average power dissipation of transients not to exceed 2.0W.

1. Peak current applies to applications rated up to 97V_{RMS}. Peak current is 30kA for applications greater than 97V.
2. Peak current applies to applications rated up to 115V_{RMS}. Peak current is 30kA for applications greater than 115V.
3. Peak current applies to applications rated up to 123V_{RMS}. Peak current is 30kA for applications greater than 123V.
4. Peak current applies to applications rated up to 132V_{RMS}. Peak current is 30kA for applications greater than 132V.

HF34 Series Ratings & Specifications

| Lead-free and RoHS Compliant Models | Model Size Disc Dia. (mm) | Maximum Rating (85°C) | | | | Specifications (25°C) | | | | |
|-------------------------------------|---------------------------|-----------------------|-------------|--------------|-----------------------------|---|-------------|-------|---|---------------------|
| | | Continuous | | Transient | | Varistor Voltage at 1mA DC Test Current | | | Maximum Clamping Voltage V_C at 200A Current (8/20 μ s) | Typical Capacitance |
| | | V_{RMS} | V_{DC} | Energy (2ms) | Peak Current 8 x 20 μ s | | | | | |
| | | $V_{M(AC)}$ | $V_{M(DC)}$ | W_{TM} | I_{TM} | Min | $V_{N(DC)}$ | Max | V_C | $f = 1\text{MHz}$ |
| Part Number | | (V) | (V) | (J) | (A) | (V) | (V) | (V) | (V) | (pF) |
| V111HF34 | 34 | 110 | 148 | 220 | 40,000 ¹ | 156 | 173 | 190 | 288 | 11,600 |
| V131HF34 | 34 | 130 | 175 | 270 | 40,000 ² | 184.5 | 205 | 225.5 | 345 | 10,000 |
| V141HF34 | 34 | 140 | 188 | 291 | 40,000 ³ | 198 | 220 | 242 | 375 | 9,000 |
| V151HF34 | 34 | 150 | 200 | 300 | 40,000 ⁴ | 216 | 240 | 264 | 405 | 8,000 |
| V181HF34 | 34 | 180 | 240 | 330 | 40,000 | 254 | 282 | 310 | 468 | 6,800 |
| V201HF34 | 34 | 200 | 265 | 350 | 40,000 | 283 | 314 | 345 | 533 | 6,350 |
| V251HF34 | 34 | 250 | 330 | 370 | 40,000 | 351 | 390 | 429 | 650 | 5,000 |
| V271HF34 | 34 | 275 | 370 | 400 | 40,000 | 387 | 430 | 473 | 730 | 4,500 |
| V301HF34 | 34 | 300 | 410 | 430 | 40,000 | 423 | 470 | 517 | 780 | 4,100 |
| V321HF34 | 34 | 320 | 420 | 460 | 40,000 | 459 | 510 | 561 | 830 | 3,800 |
| V331HF34 | 34 | 330 | 435 | 475 | 40,000 | 467 | 518.5 | 570 | 843 | 3,750 |
| V351HF34 | 34 | 350 | 460 | 500 | 40,000 | 495 | 549.5 | 604 | 894 | 3,600 |
| V391HF34 | 34 | 385 | 510 | 550 | 40,000 | 545 | 604 | 663 | 1,000 | 3,500 |
| V421HF34 | 34 | 420 | 560 | 600 | 40,000 | 612 | 680 | 748 | 1,130 | 3,000 |
| V441HF34 | 34 | 440 | 587 | 620 | 40,000 | 622 | 690 | 758 | 1,150 | 2,900 |
| V481HF34 | 34 | 480 | 640 | 650 | 40,000 | 675 | 750 | 825 | 1,240 | 2,700 |
| V511HF34 | 34 | 510 | 675 | 700 | 40,000 | 738 | 820 | 902 | 1,350 | 2,500 |
| V551HF34 | 34 | 550 | 710 | 755 | 40,000 | 778 | 863.5 | 949 | 1,404 | 2,390 |
| V571HF34 | 34 | 570 | 730 | 770 | 40,000 | 819 | 910 | 1001 | 1,480 | 2,200 |
| V661HF34 | 34 | 660 | 850 | 900 | 40,000 | 945 | 1050 | 1155 | 1,720 | 2,000 |
| V681HF34 | 34 | 680 | 875 | 925 | 40,000 | 962 | 1067.5 | 1173 | 1777 | 1,900 |
| V751HF34 | 34 | 750 | 970 | 1050 | 40,000 | 1080 | 1200 | 1320 | 2,000 | 1,800 |

Note:

1. Peak current applies to applications rated up to $97V_{RMS}$. Peak current is 30kA for applications greater than 97V.
2. Peak current applies to applications rated up to V_{RMS} . Peak current is 30kA for applications greater than 115V.
3. Peak current applies to applications rated up to V_{RMS} . Peak current is 30kA for applications greater than 123V.
4. Peak current applies to applications rated up to V_{RMS} . Peak current is 30kA for applications greater than 132V.

HG34 Series Ratings & Specifications

| Lead-free and RoHS Compliant Models | Model Size Disc Dia. (mm) | Maximum Rating (85°C) | | | | Specifications (25°C) | | | | |
|-------------------------------------|---------------------------|-----------------------|-------------|--------------|-----------------------------|---|--------|-------------|---|---------------------|
| | | Continuous | | Transient | | Varistor Voltage at 1mA DC Test Current | | | Maximum Clamping Voltage V_C at 200A Current (8/20 μ s) | Typical Capacitance |
| | | V_{RMS} | V_{DC} | Energy (2ms) | Peak Current 8 x 20 μ s | | | | | |
| | | Part Number | $V_{M(AC)}$ | $V_{M(DC)}$ | W_{TM} | I_{TM} | Min | $V_{N(DC)}$ | Max | V_C |
| | (V) | (V) | (J) | (A) | (V) | (V) | (V) | (V) | (pF) | |
| V111HG34 | 34 | 110 | 148 | 220 | 40,000 ¹ | 156 | 173 | 190 | 288 | 11,600 |
| V131HG34 | 34 | 140 | 175 | 270 | 40,000 ² | 184.5 | 205 | 225.5 | 345 | 10,000 |
| V141HG34 | 34 | 130 | 188 | 291 | 40,000 ³ | 198 | 220 | 242 | 375 | 9,000 |
| V151HG34 | 34 | 150 | 200 | 300 | 40,000 ⁴ | 216 | 240 | 264 | 405 | 8,000 |
| V181HG34 | 34 | 180 | 240 | 330 | 40,000 | 254 | 282 | 310 | 468 | 6,800 |
| V201HG34 | 34 | 200 | 265 | 350 | 40,000 | 283 | 314 | 345 | 533 | 6,350 |
| V251HG34 | 34 | 250 | 330 | 370 | 40,000 | 351 | 390 | 429 | 650 | 5,000 |
| V271HG34 | 34 | 275 | 370 | 400 | 40,000 | 387 | 430 | 473 | 730 | 4,500 |
| V301HG34 | 34 | 300 | 410 | 430 | 40,000 | 423 | 470 | 517 | 780 | 4,100 |
| V321HG34 | 34 | 320 | 420 | 460 | 40,000 | 459 | 510 | 561 | 830 | 3,800 |
| V331HG34 | 34 | 330 | 435 | 475 | 40,000 | 467 | 518.5 | 570 | 843 | 3,750 |
| V351HG34 | 34 | 350 | 460 | 500 | 40,000 | 495 | 549.5 | 604 | 894 | 3,600 |
| V331HG34 | 34 | 385 | 510 | 550 | 40,000 | 545 | 604 | 663 | 1,000 | 3,500 |
| V421HG34 | 34 | 420 | 560 | 600 | 40,000 | 612 | 680 | 748 | 1,130 | 3,000 |
| V441HG34 | 34 | 440 | 587 | 620 | 40,000 | 622 | 690 | 758 | 1,150 | 2,900 |
| V481HG34 | 34 | 480 | 640 | 650 | 40,000 | 675 | 750 | 825 | 1,240 | 2,700 |
| V511HG34 | 34 | 510 | 675 | 700 | 40,000 | 738 | 820 | 902 | 1,350 | 2,500 |
| V551HG34 | 34 | 550 | 710 | 755 | 40,000 | 778 | 863.5 | 949 | 1,404 | 2,390 |
| V571HG34 | 34 | 570 | 730 | 770 | 40,000 | 819 | 910 | 1001 | 1,480 | 2,200 |
| V661HG34 | 34 | 660 | 850 | 900 | 40,000 | 945 | 1050 | 1155 | 1,720 | 2,000 |
| V681HG34 | 34 | 680 | 875 | 925 | 40,000 | 962 | 1067.5 | 1173 | 1,777 | 1,900 |
| V751HG34 | 34 | 750 | 970 | 1050 | 40,000 | 1080 | 1200 | 1320 | 2,000 | 1,800 |

Note :

1. Peak current applies to applications rated up to 97 V_{RMS} . Peak current is 30kA for applications greater than 97V.
2. Peak current applies to applications rated up to 115 V_{RMS} . Peak current is 30kA for applications greater than 115V.
3. Peak current applies to applications rated up to 123 V_{RMS} . Peak current is 30kA for applications greater than 123V.
4. Peak current applies to applications rated up to 132 V_{RMS} . Peak current is 30kA for applications greater than 132V.

Power Dissipation Ratings

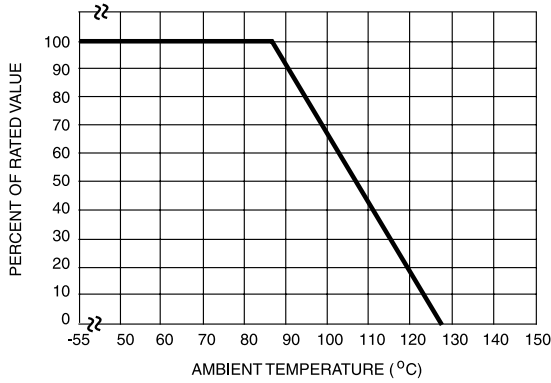

Figure 1

Should transients occur in rapid succession, the average power dissipation result is simply the energy (watt-seconds) per pulse times the number of pulses per second. The power so developed must be within the specifications shown on the Device Ratings and Specifications Table for the specific device. The operating values must be derated as shown in above.

Peak Pulse Current Test Waveform

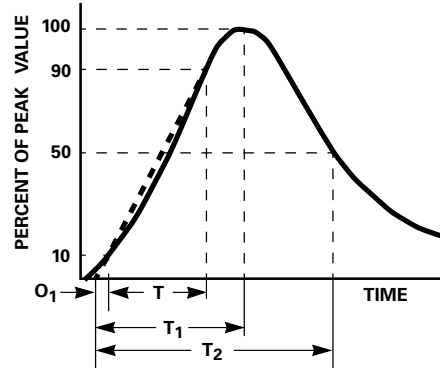

Figure 2

- O_1 = Virtual Origin of Wave
- T = Time from 10% to 90% of Peak
- T_1 = Rise Time = $1.25 \times T$
- T_2 = Decay Time

Example - For an 8/20 μ s Current Waveform:

- $8\mu s = T_1 =$ Rise Time
- $20\mu s = T_2 =$ Decay Time

Clamping Voltage for HB34, HF34 and HG34 Series

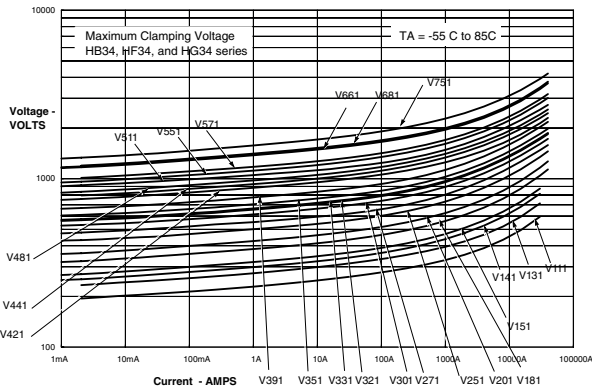

Figure 3

Surge Current Rating Curves for HB34, HF34 and HG34 Series

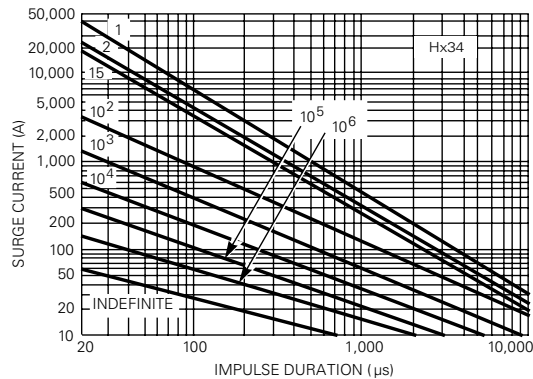

Figure 4

NOTE: If pulse ratings are exceeded, a shift of V_{NDC} (at specified current) of more than +/-10% could result. This type of shift, which normally results in a decrease of V_{NDC} , may result in the device not meeting the original published specifications, but it does not prevent the device from continuing to function, and to provide ample protection.

Wave Solder Profile

Non Lead-free Profile

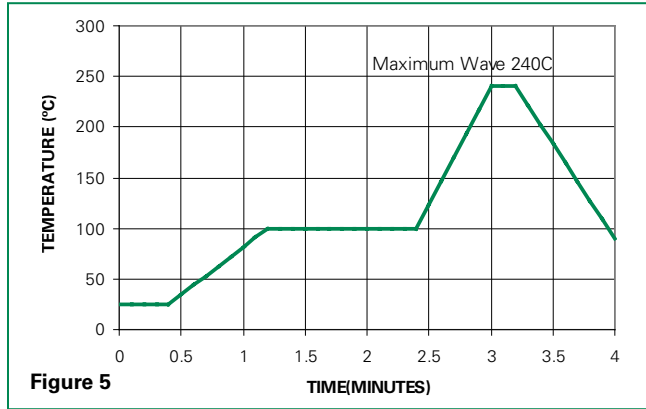

Figure 5

Lead-free Profile

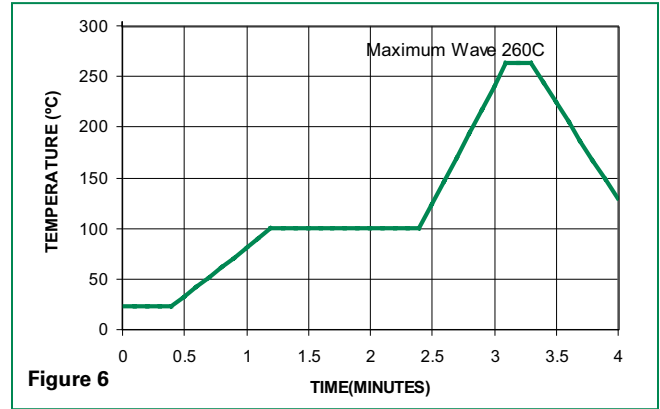

Figure 6

Physical Specifications

| | |
|----------------------------------|--|
| Lead Material | Tin-plated Copper |
| Soldering Characteristics | Solderability per MIL-STD-202, Method 208 |
| Insulating Material | Cured, flame retardant epoxy polymer meets UL94V-0 requirements. |
| Device Labeling | LF, Part Number and date code |

Environmental Specifications

| | |
|------------------------------|---|
| Operating Temperature | -55°C to +125°C |
| Storage Temperature | -55°C to +125°C |
| Humidity Aging | +85°C, 85% RH, 1000 hours +/-10% Voltage |
| Thermal Shock | +85°C to -40°C 5 times +/-10% Voltage |
| Solvent Resistance | MIL-STD-202, Method 215 |
| Moisture Sensitivity | Level 1, J-STD-020 |

Dimensions (mm)

HB34 Series

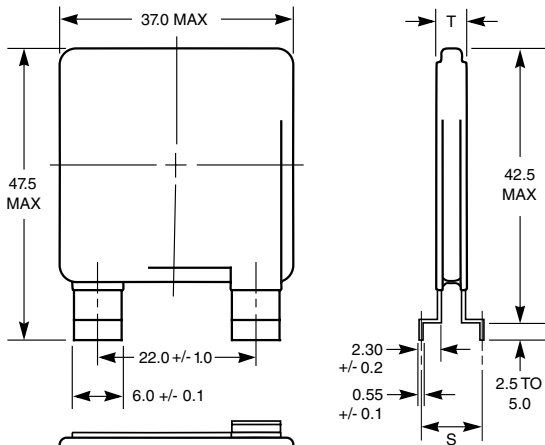

NOTE: Dimension in mm is typical, unless otherwise specified.

HB34 Series Thickness and Terminal Offset Dimensions

| Part Type | T Body Thickness (Max) | S Mounting Terminal Offset |
|-----------|------------------------|----------------------------|
| V111HB34 | 5.5 | 5.30 +/- 0.65 |
| V131HB34 | 5.7 | 5.50 +/- 0.65 |
| V141HB34 | 5.8 | 5.70 +/- 0.65 |
| V151HB34 | 5.9 | 5.90 +/- 0.65 |
| V181HB34 | 6.0 | 6.10 +/- 0.65 |
| V201HB34 | 6.0 | 6.10 +/- 0.65 |
| V251HB34 | 6.1 | 6.25 +/- 0.65 |
| V271HB34 | 6.4 | 6.50 +/- 0.65 |
| V301HB34 | 6.7 | 6.70 +/- 0.65 |
| V321HB34 | 6.9 | 6.90 +/- 0.65 |
| V331HB34 | 7.0 | 6.95 +/- 0.65 |
| V351HB34 | 7.3 | 7.20 +/- 0.85 |
| V391HB34 | 7.6 | 7.50 +/- 0.85 |
| V421HB34 | 7.8 | 7.85 +/- 0.85 |
| V441HB34 | 8.0 | 7.95 +/- 1.00 |
| V481HB34 | 8.3 | 8.25 +/- 1.00 |
| V511HB34 | 8.8 | 8.60 +/- 1.00 |
| V551HB34 | 9.1 | 8.55 +/- 1.5 |
| V571HB34 | 9.4 | 8.85 +/- 1.5 |
| V661HB34 | 10.2 | 9.65 +/- 1.5 |
| V681HB34 | 10.4 | 10.35 +/- 1.5 |
| V751HB34 | 10.7 | 10.65 +/- 1.5 |

HF34 Series

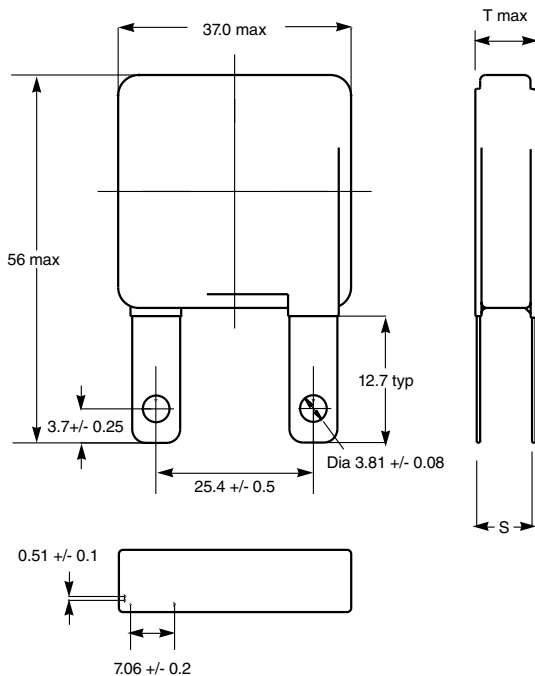

Note: Terminal Material Tin-plated Cover

HF34 Series Thickness and Terminal Offset Dimensions

| Part Type | T Body Thickness (Max) | S Mounting Terminal Offset |
|-----------|------------------------|----------------------------|
| V111HF34 | 5.5 | 2.0 +/- 0.65 |
| V131HF34 | 5.7 | 2.1 +/- 0.65 |
| V141HF34 | 5.8 | 2.2 +/- 0.65 |
| V151HF34 | 5.9 | 2.4 +/- 0.65 |
| V181HF34 | 6.0 | 2.5 +/- 0.65 |
| V201HF34 | 6.0 | 2.6 +/- 0.65 |
| V251HF34 | 6.1 | 2.7 +/- 0.85 |
| V271HF34 | 6.4 | 2.9 +/- 0.85 |
| V301HF34 | 6.7 | 3.2 +/- 0.85 |
| V321HF34 | 6.9 | 3.4 +/- 0.85 |
| V331HF34 | 7.0 | 3.5 +/- 0.85 |
| V351HF34 | 7.3 | 3.9 +/- 0.85 |
| V391HF34 | 7.6 | 4.2 +/- 0.85 |
| V421HF34 | 7.8 | 4.4 +/- 0.85 |
| V441HF34 | 8.0 | 4.5 +/- 0.85 |
| V481HF34 | 8.3 | 4.8 +/- 1.0 |
| V511HF34 | 8.8 | 5.2 +/- 1.0 |
| V551HF34 | 9.1 | 5.5 +/- 1.0 |
| V571HF34 | 9.4 | 5.7 +/- 1.5 |
| V661HF34 | 10.2 | 6.5 +/- 1.5 |
| V681HF34 | 10.4 | 6.7 +/- 1.5 |
| V751HF34 | 10.7 | 7.3 +/- 1.5 |

Dimensions (mm)

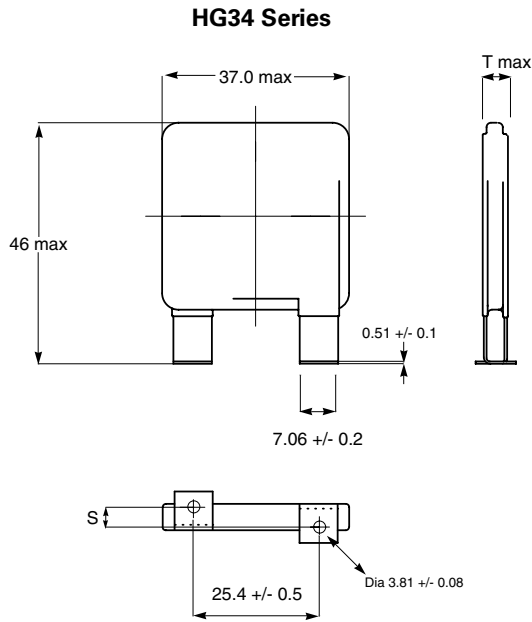

Note: Terminal Material Tin-plated Cover

HG34 Series Thickness and Terminal Offset Dimensions

| Part Type | T Body Thickness (Max) | S Mounting Terminal Offset |
|-----------|------------------------|----------------------------|
| V111HG34 | 5.5 | 6.0 -/+ 0.65 |
| V131HG34 | 5.7 | 5.8 -/+ 0.65 |
| V141HG34 | 5.8 | 5.6 -/+ 0.65 |
| V151HG34 | 5.9 | 5.5 -/+ 0.65 |
| V181HG34 | 6.0 | 5.4 -/+ 0.65 |
| V201HG34 | 6.0 | 5.4 -/+ 0.65 |
| V251HG34 | 6.1 | 5.2 -/+ 0.65 |
| V271HG34 | 6.4 | 4.9 -/+ 0.65 |
| V301HG34 | 6.7 | 4.7 -/+ 0.85 |
| V321HG34 | 6.9 | 4.5 -/+ 0.85 |
| V331HG34 | 7.0 | 4.4 -/+ 0.85 |
| V351HG34 | 7.3 | 4.1 -/+ 0.85 |
| V391HG34 | 7.6 | 3.8 -/+ 0.85 |
| V421HG34 | 7.8 | 3.5 -/+ 0.85 |
| V441HG34 | 8.0 | 3.3 -/+ 0.85 |
| V481HG34 | 8.3 | 3.1 -/+ 1.0 |
| V511HG34 | 8.8 | 2.7 -/+ 1.0 |
| V551HG34 | 9.1 | 2.4 -/+ 1.0 |
| V571HG34 | 9.4 | 2.2 -/+ 1.5 |
| V661HG34 | 10.2 | 1.4 -/+ 1.5 |
| V681HG34 | 10.4 | 1.2 -/+ 1.5 |
| V751HG34 | 10.7 | 0.6 -/+ 1.5 |

*Dimensions in mm.

Part Numbering System

