

inductive sensor
ring sensor
Bi30R-W30-DAN6X-H1141

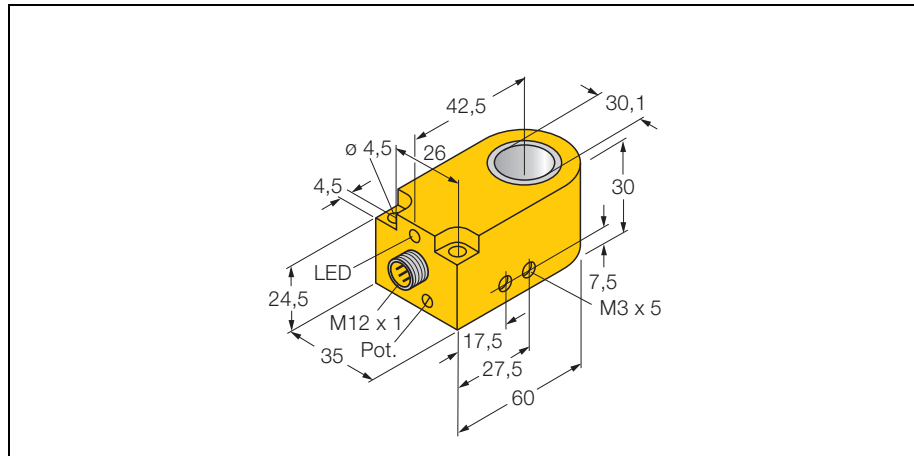

- rectangular, 30 mm high
- plastic, PA12-GF30
- pulse duration 100 ms
- 3-wire DC, 10...30 VDC
- dynamic output performance
- normally open npn output
- connector, M12 x 1

Wiring diagram

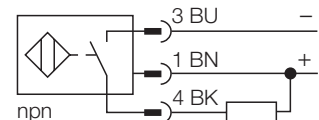

Functional principle

Inductive sensors are designed for wear-free and non-contact detection of metal objects. For this purpose they use a high-frequency electro-magnetic AC field that interacts with the target. Inductive ring sensors generate this field by an LC resonant circuit. The target acts as the coil core.

Type	Bi30R-W30-DAN6X-H1141
Ident-No.	1404501
Internal ring diameter	30.1 mm
Steel ball diameter (DIN 5401)	≥ 3 mm
Fly-by speed	0.1... 50 m/s
Pulse stop	≥ 5 ms
Pulse duration	100ms ± 20 %
Ambient temperature	-25...+ 70 °C
Operating voltage	10... 30VDC
Residual ripple	≤ 10 % U _{SS}
DC rated operational current	≤ 200 mA
No-load current I ₀	≤ 10 mA
Residual current	≤ 0.1 mA
Rated insulation voltage	≤ 0.5 kV
Short-circuit protection	yes / cyclic
Voltage drop at I _e	≤ 2.5V
Wire breakage / Reverse polarity protection	yes / complete
Output function	3-wire, normally open, npn
Switching frequency	≤ 0.008 kHz
Housing	ring sensor, W30
Dimensions	60 x 35 x 30 mm
Housing material	plastic, PA12-GF30
Connection	connectors, M12 x 1
Coil body	plastic, POM
Vibration resistance	55 Hz (1 mm)
Shock resistance	30g (11 ms)
Degree of protection	IP67
Display switch state	LED yellow

inductive sensor
ring sensor
Bi30R-W30-DAN6X-H1141

Mounting instructions

	minimum distances
Distance D	120 mm
Distance W	120 mm
Distance S	30 mm
Distance G	120 mm

