

TEST/CHARACTERISTICS	STANDARD REFERENCE	VALUES/REMARKS		
----------------------	--------------------	----------------	--	--

ELECTRICAL CHARACTERISTICS

Impedance		50 Ω		
Frequency range		DC-4 GHz		
Typical V.S.W.R. <i>Straight models cable group : 2/50, 2.6/50, 5/50, 10 + 11/50, .141"</i> <i>Right angle models 2/50, 2.6/50, 5/50,</i>		1 GHz 1.12	2.5 GHz 1.18 1.30 max	4 GHz 1.22
Insertion loss <i>straight connector</i> <i>right-angle connector</i>		0.05 0.08	0.07 0.16	0.13 0.20
RF Leakage		- 55 dB min from 2 to 3 GHz		
Insulation resistance		5000 MΩ min	5000 MΩ min	5000 MΩ min
Contact resistance <i>center contact</i> <i>outer contact</i>	MIL	1.5 mΩ 0.2 mΩ		
Working voltage in VRMS <i>at sea level</i> <i>(at 21 000m)</i>		500 125		
Dielectric withstanding voltage in VRMS <i>at sea level</i> <i>(at 21 000m)</i>		1500 375		
RF testing voltage in VRMS <i>sea level (5 MHz)</i>		1000		

MECHANICAL CHARACTERISTICS

Durability		500 matings		
Force to engage and disengage <i>axial torque</i>		13.6 N max 28.6 Ncm		
Coupling nut retention force	MIL	445 N		
Cable retention force <i>cable 2/50, 2.6/50</i> <i>cable 5/50, 10 + 11/50</i> <i>cable .141"</i>		227 N		
Center contact retention force		27.2 N		

ENVIRONMENTAL CHARACTERISTICS

Temperature range <i>flexible cables</i> <i>semi-rigid cables</i>	MIL	- 65°C + 165°C - 65°C + 105°C		
Thermo cycling test		MIL STD 202, method 107, condition B		
Thermal shock		MIL STD 202, method 107, condition B		
Hight temperature endurance		MIL STD 202, method 108		
Corrosion salt spray		MIL STD 202, method 101, condition B		
Vibration		MIL STD 202, method 204, condition B		
Shock		MIL STD 202, method 213, condition G		
Moisture resistance		MIL STD 202, method 106		
Hermetic test		MIL STD 202, method 112, condition C vacuum 10 ⁻⁶ Hgmm (Torr) leakage rate < 10 ⁻⁶ atm/cm ³ /s		
Barometric pressure		Pressure test : 3.5 bars; duration : 2 mn; temperature : 15° C to 25 °C		

BNC 50 Ω

CHARACTERISTICS

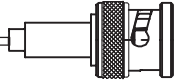

MATERIALS

Bodies		Brass
Center contact	<i>male</i> <i>female</i>	Brass Bronze or heat treated beryllium following QQ-C-530
Nut		Brass
Insulator		PTFE
Gasket		Silicon rubber

PLATINGS

Bodies		Nickel
Center contacts		Gold

POWER RATING

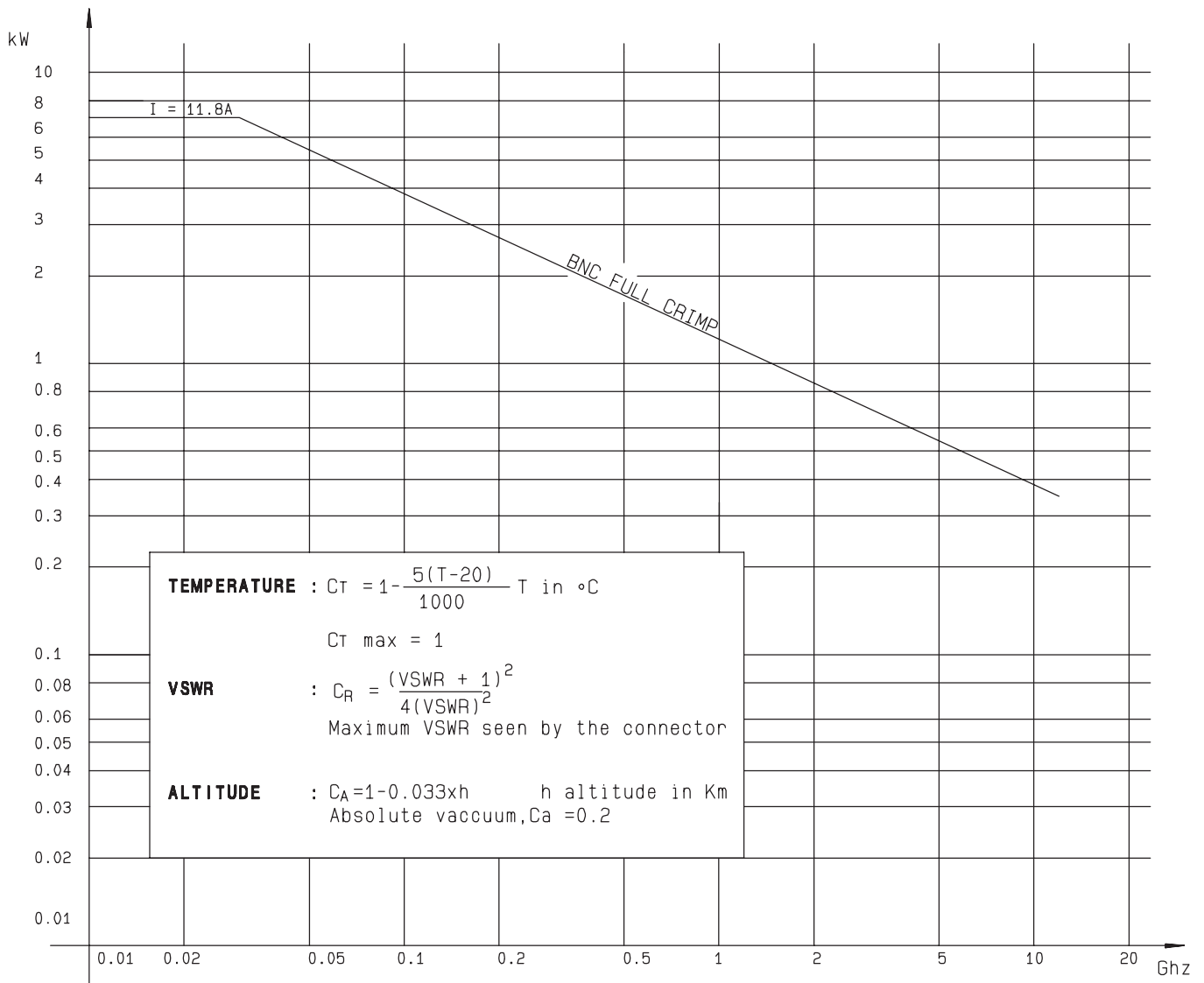

Standard packaging : unit

All dimensions are given in mm.

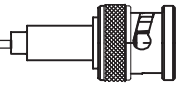

STRAIGHT BULKHEAD JACKS CLAMP TYPE

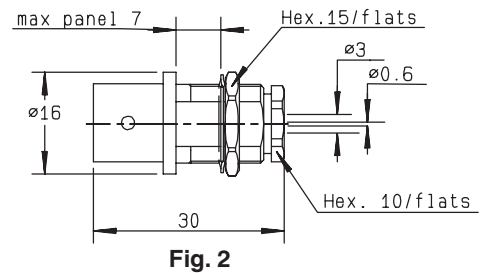
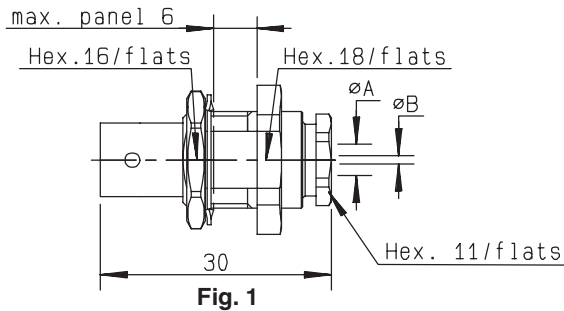

cable	part number	fig.	dimensions			captive center contact	assembly	cut out	note
			A	B					
2/50/S	R141 323 000*	1	2.2	0.6		yes	M02	P05	fully sealed
2.6/50/S	R141 304 000*	2				yes	M02	P05	fully sealed
2.6/50/S	R141 324 000	1	3.1	0.6		yes	M02	P05	fully sealed
5/50/S + D	R141 327 000*	1	5.6	1.05		no	M01	P05	panel sealed
.141"	R141 338 000●	1	3.65	1.05		no	M10	P05	panel sealed/semi-rigid cable

STRAIGHT BULKHEAD JACKS CRIMP TYPE FOR FLEXIBLE CABLES

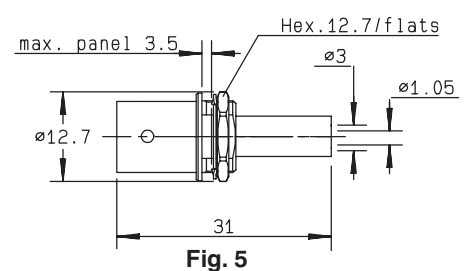
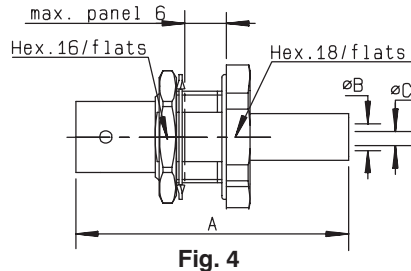
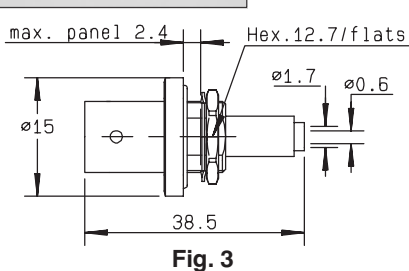
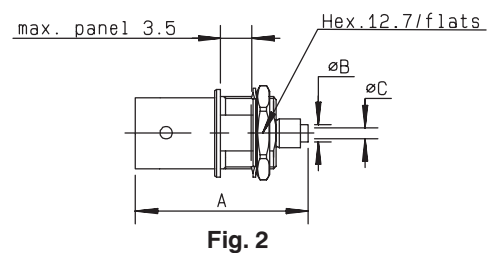
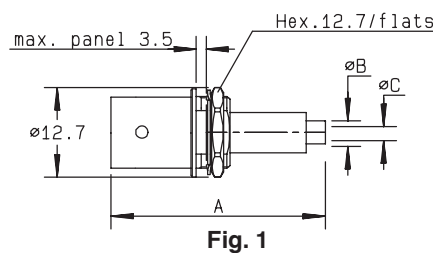

cable	part number	fig.	dimensions			captive center contact	assembly	cut out	note
			A	B	C				
2/50/S	R141 303 503●*	2	25.4	2	0.4	yes	M12	P07	reverse crimping
2/50/D	R141 301 000●	1	33.35	1.1	0.6	yes	M05	P07	
2.6/50/S	R141 306 000*	1	34	1.7	0.6	yes	M05	P07	
2.6/50/S	R141 306 503	2	26	2.95	0.6	yes	M12	P07	reverse crimping
2.6/50/S	R141 331 400●	3				yes	M05	P07	panel sealed
2.6/50/S	R141 331 500*	4	38.5	1.7	0.6	yes	M05	P09	panel sealed
5/50/S	R141 308 000	5	31	3	1.05	yes	M07	P07	single piece body
5/50/S	R141 332 500	4	35.5	3.1	1.05	yes	M07	P05 or P09	panel sealed/single piece body

For others types of cables (75Ω, 93Ω or BT cables), please see "additional connectors" on page 36-37.

● Upon request

* Packaging = 100 pieces.

M 07

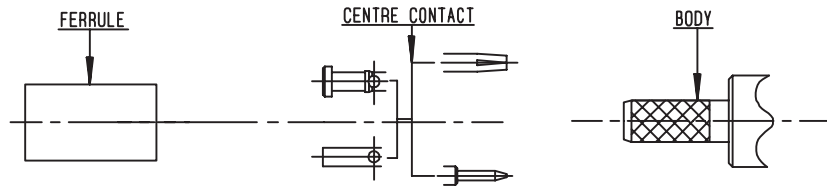

P/N	HEX. DIM. H	FERRULE		CENTER CONTACT	
		DIES INCLUDED	MIL STANDARD R282 293 000 (M22520/5-01)+DIES	DIES INCLUDED	MIL STANDARD R282 293 000 (M22520/5-01)+DIES
R141 082 000 R141 083 000 R141 182 000 R141 183 000	1,73-5,4	R282 223 000	R282 235 011 (M22520/5-11)	R282 223 000	R282 235 011 (M22520/5-11)
R142 184 000	1,73-6,48		R282 235 013 (M22520/5-13)		R282 235 013 (M22520/5-13)
R141 220 000 R141 237 000			R282 235 011 (M22520/5-11)		R282 235 011 (M22520/5-11)
R142 242 000			R282 235 013 (M22520/5-13)		R282 235 013 (M22520/5-13)
R141 292 000			R282 235 011 (M22520/5-11)		R282 235 011 (M22520/5-11)
R142 295 000	1,79-10,54		R282 231 000		R282 235 116 (Y116 DANIELS)
R141 308 000 R141 332 500	1,73-5,4		R282 223 000		R282 235 011 (M22520/5-11)
R142 085 000	1,73-6,48				R282 235 013 (M22520/5-13)
R142 095 000					R282 235 011 (M22520/5-11)
R142 083 000	5.4		R282 223 000		R282 235 011 (M22520/5-11)

1

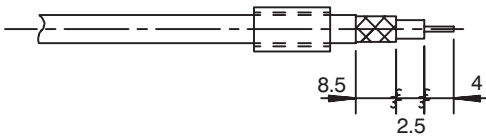

- 1.1 Slide onto the cable the ferrule
- 1.2 Strip the cable .

2

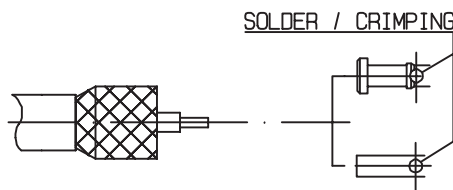

- 2.1 Fan the braid.
- 2.2 Slide on centre contact until it bottoms against cable dielectrique .
- 2.3 Crimp or solder the centre contact .

