

Datasheet

SP-CO Roller Lever Microswitch, 0.03 A@ 250 V dc, 0.25 A@ 250 V dc, 15 A@ 440 V ac, 4 A@ 440 V ac

RS Stock 797-2517

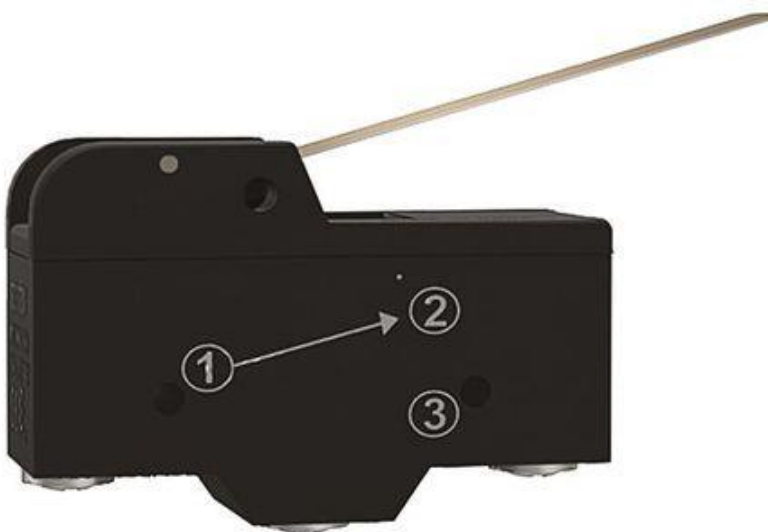

Dimensions: (mm)

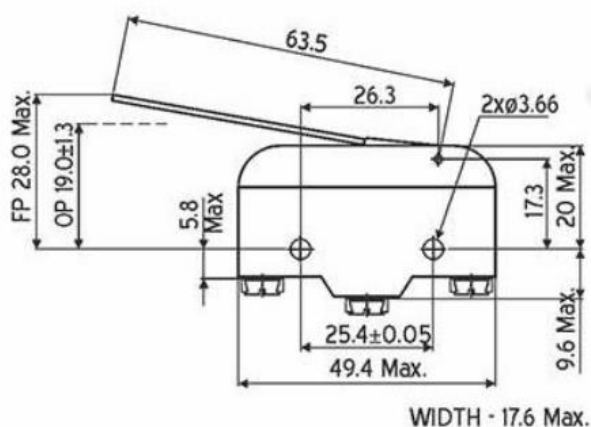

- Single pole change over , snap-acting switches
- Fine silver contacts
- Beryllium copper trident spring operating mechanism
- Easy wire-up screw and cup-washer terminals characterised by extended creepage distance between terminals.
- Conform to IEC 1058-1 standard



Specifications

Characteristics	
Actuating force	131 gms. (max)
Release force	21 gms. (min)
Pre-travel	6.1 mm. (max)
Over-travel	2.3 mm.
Movement differential	1.0 mm. (max)
Salient features	Nylon roller of 9.5mm. Dia x4.6mm width mounted on stainless steel lever of reduced length

Technical Characteristics	
Contact resistance	10 milliohms (max)
Insulation resistance	1000 megaohms (min)
Voltage proof	1 KV AC for one minute
Terminals	M 3.5 screw cup washer
Electrical life	50,000 operations
Mechanical life	1 million operations

Electrical Ratings	
Load	Rating
AC (resistive)	15 A at 125V or 15A at 250V or 15 A at 440V
AC (inductive)	15 A at 125V or 15A at 250V or 4 A at 440V
DC (resistance)	0.5 A at 125V or 0.25 A at 250V
DC (inductive)	0.05 A at 125V or 0.03 A at 250V