

DRAWING FOR REFERENCE: This is subject to change without notice
08/11/2012

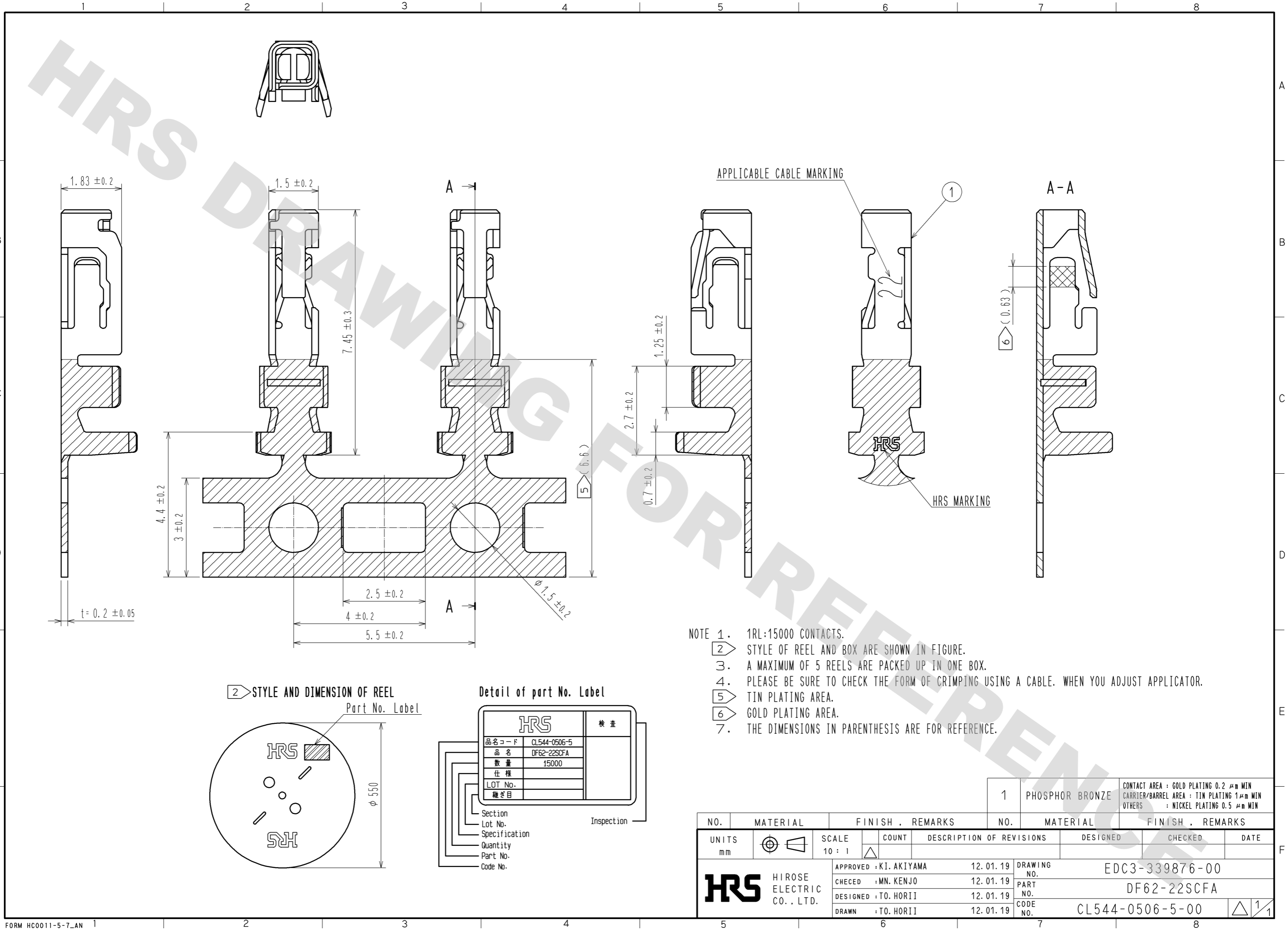

- NOTE 1. 1RL:15000 CONTACTS.
 2. STYLE OF REEL AND BOX ARE SHOWN IN FIGURE.
 3. A MAXIMUM OF 5 REELS ARE PACKED UP IN ONE BOX.
 4. PLEASE BE SURE TO CHECK THE FORM OF CRIMPING USING A CABLE. WHEN YOU ADJUST APPLICATOR.
 5. TIN PLATING AREA.
 6. GOLD PLATING AREA.
 7. THE DIMENSIONS IN PARENTHESIS ARE FOR REFERENCE.

2. STYLE AND DIMENSION OF REEL

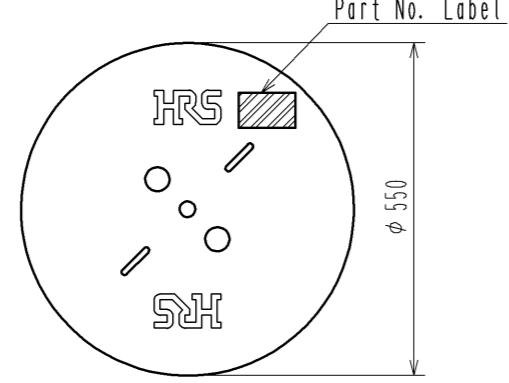

Detail of part No. Label

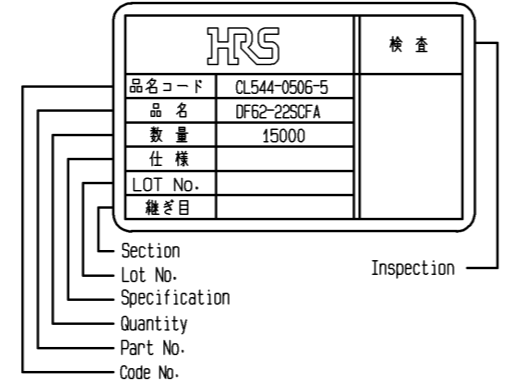

NO.	MATERIAL	FINISH . REMARKS	NO.	MATERIAL	FINISH . REMARKS
1	PHOSPHOR BRONZE	CONTACT AREA : GOLD PLATING 0.2 μm MIN CARRIER/BARREL AREA : TIN PLATING 1 μm MIN OTHERS : NICKEL PLATING 0.5 μm MIN			

UNITS	SCALE	COUNT	DESCRIPTION OF REVISIONS	DESIGNED	CHECKED	DATE
mm	10 : 1	△				
APPROVED : KI. AKIYAMA			12.01.19	DRAWING NO. EDC3-339876-00		
CHECKED : MN. KENJO			12.01.19	PART NO. DF62-22SCFA		
DESIGNED : TO. HORII			12.01.19	CODE NO. CL544-0506-5-00		
DRAWN : TO. HORII			12.01.19	1/1		