



Analog signal converters
CC range

Serial data converters
IPLH range

Content

Analog signal converters CC range	151
Ordering details	155
Technical data	168
Dimensional drawings	173
NEW Serial data converters ILPH range	175

Notes

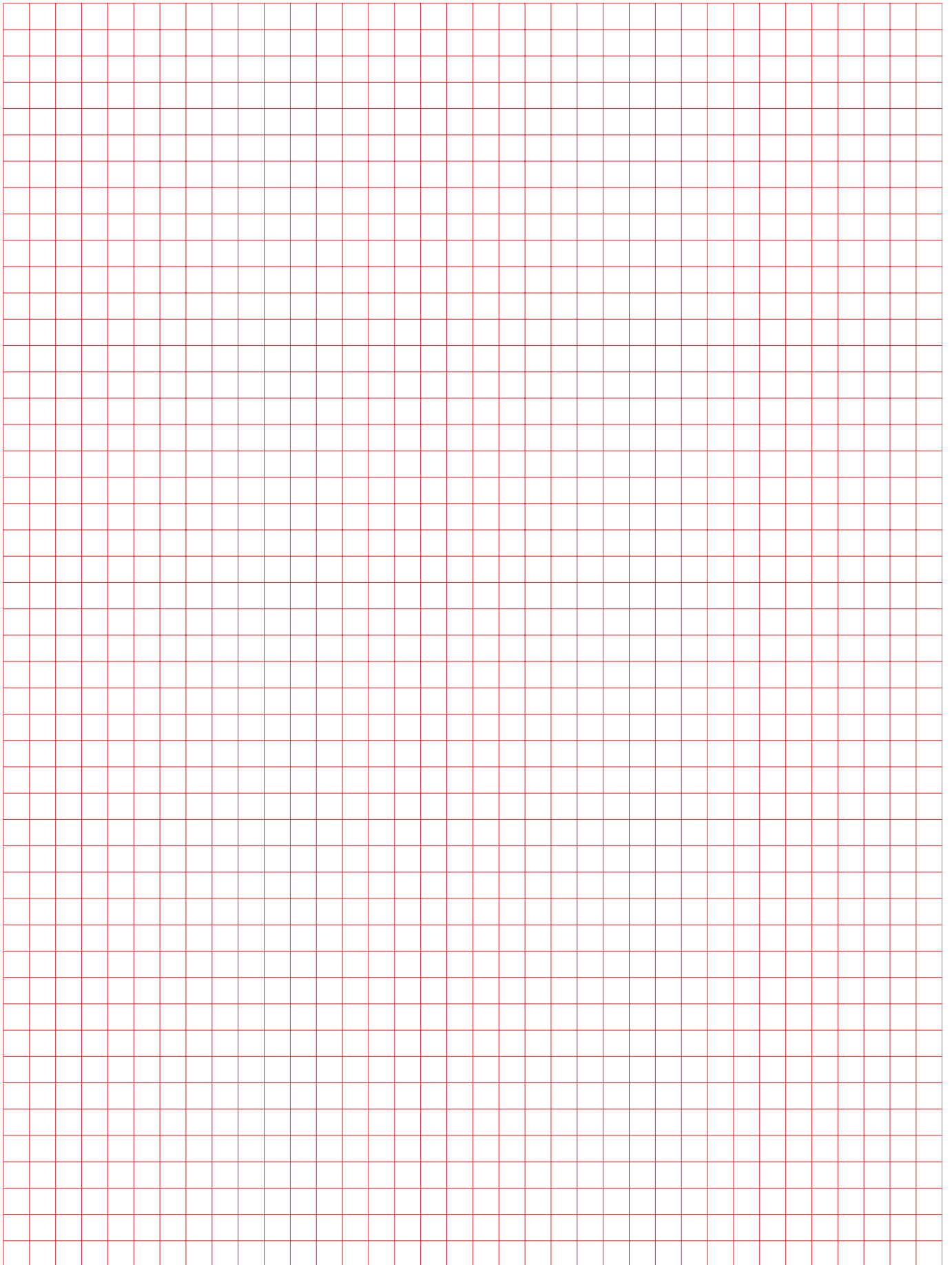



Content

Benefits and advantages of analog signal converters	152
Application, approvals	154
Analog standard signal converters CC-E/STD, CC-E x/x, CC-U/STD, CC-U/STDR	
Ordering details	155
Technical data	168
Dimensional drawings	173
Temperature signal converters for RTD sensors CC-E/RTD, CC-U/RTD, CC-U/RTDR	
Ordering details	158
Technical data	168
Dimensional drawings	173
Temperature signal converters for thermocouples CC-E/TC, CC-U/TC, CC-U/TCR	
Ordering details	157
Technical data	168
Dimensional drawings	173
Measuring converters for currents (E/I) and (U/I) and voltages (U/V) CC-E/I, CC-E I _{AC} / ILPO, CC-U/I, CC-U/V	
Ordering details	164
Technical data	169
Dimensional drawings	173

Analog signal converters CC range Benefits and advantages

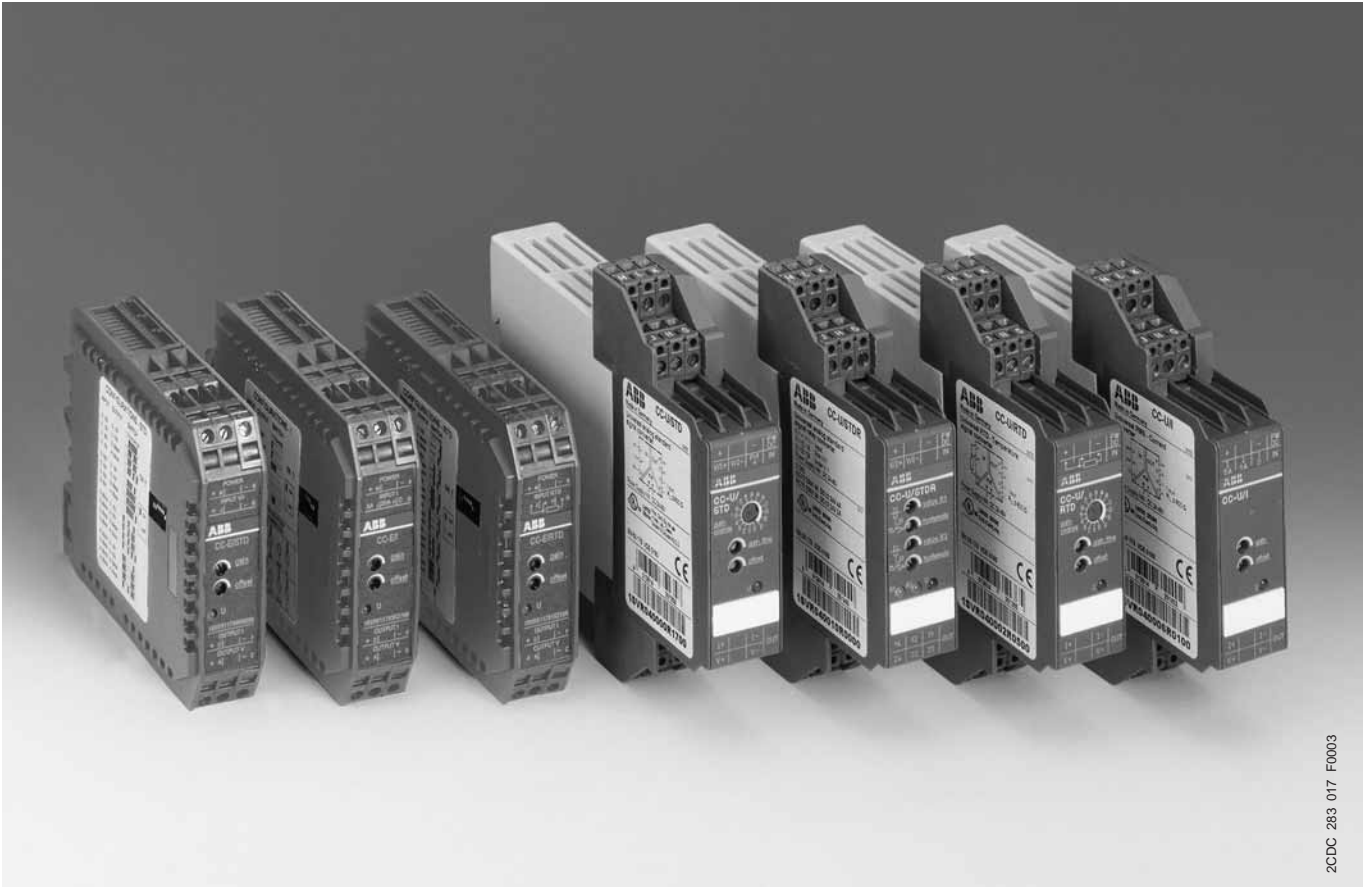

2CDC 283 017 F0003

5

CC-E product range for analog signal processing

- Universally configurable devices and single-function devices
- Adjustment and operating elements on the front side
- Safe operation by electrical 3-way isolation
- Unambiguous and clear connecting terminal markings

Conversion, measurement and separation of

- standard signals (0-5 V, 0-10 V, 0-20 mA, 4-20 mA)
- temperature signals of RTD sensors (PT 100)
- thermocouple signals (types J and K)
- current measurement signals (0-5 A, 0-20 A AC/DC)

Characteristics of single-function devices

- No adjustment or balancing necessary.

Characteristics of universal devices

- The required input and output ranges can be configured by means of directly accessible DIP switches positioned on the side
- Gain adjustment of $\pm 5\%$ by means of an adjustment potentiometer on the front-side
- Offset adjustment of $\pm 5\%$ by means of adjustment potentiometers on the front-side

Analog signal converters CC range Benefits and advantages

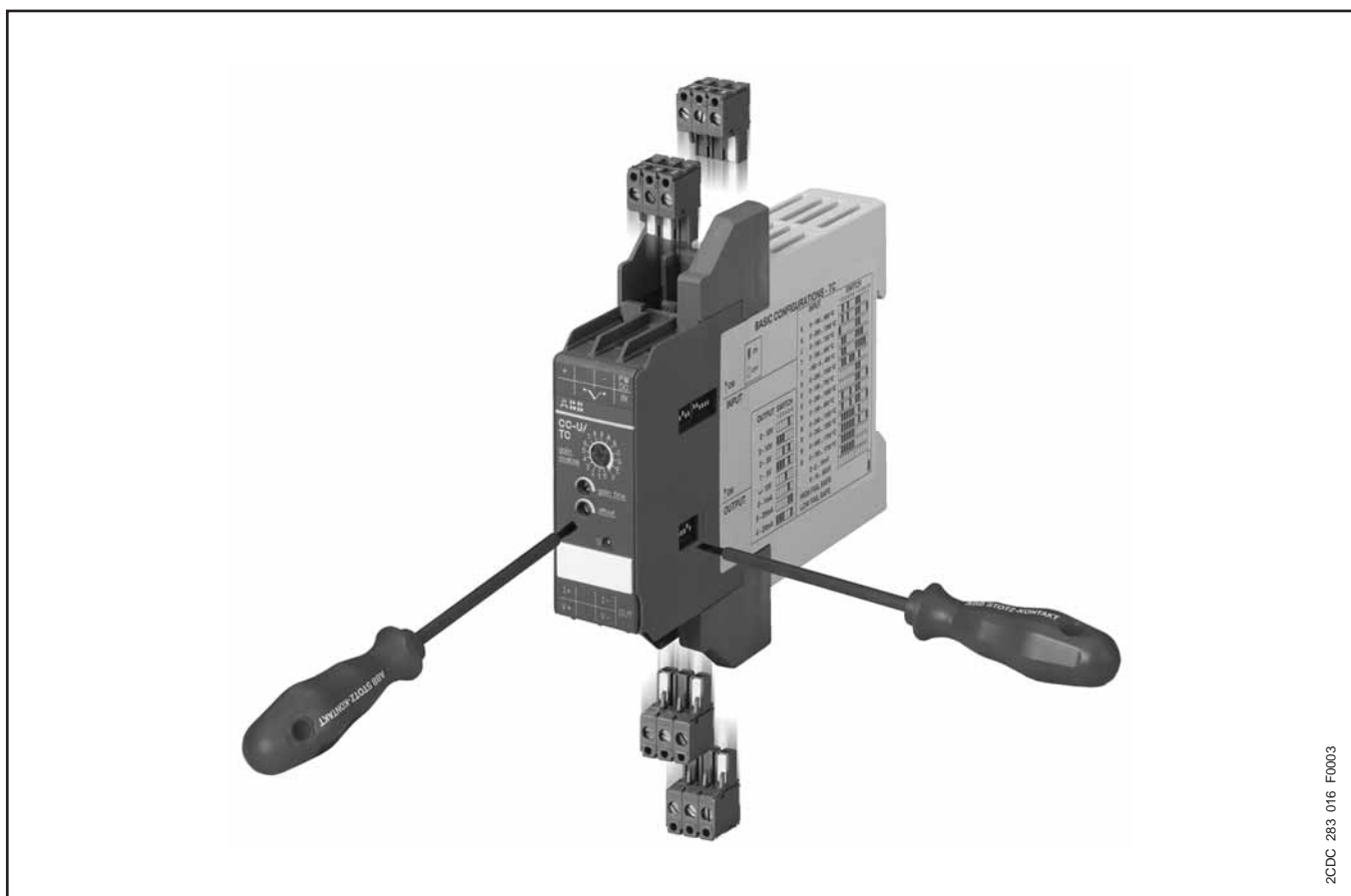

2CDC 283 016 F0003

5

CC-U product range for analog signal processing

- 8 different standard signal outputs on one device
- Input and output side universally configurable
- Also available with 2 threshold relay outputs
- Adjustment and operating elements on the front side
- Safe operation by electrical 3-way isolation
- Plug-in connecting terminals, unambiguously and clearly marked

Conversion, measurement and separation of

- standard signals
- signals of RTD sensors (PT10, PT100, PT1000)
- thermocouple signals
- RMS values of currents and voltages

Characteristics

- The required input and output ranges can be configured for all devices by means of directly accessible DIP switches positioned on the side.
- Due to the wide input range of the gain and offset stages all input signals between the minimum and the maximum input value can be universally converted to all common output signals.
- Devices for DC or AC (50/60 Hz) supply available.

Analog signal converters

CC range

Application, approvals

Applications for analog signal processing and correct solution using CC-E and CC-U converters

Nearly every process includes a control system that receives data by means of analog signals and then evaluates the data and sets the respective parameters correspondingly.

When transmitting analog signals numerous problems may arise which can disturb or even block an ideal behavior of the process.

Below we have listed some processing problems together with the respective solutions to solve these problems:

Signal conversion

Sometimes the available signals cannot be processed by the controller or the actuator. In this case, signal converters are required to convert the input signal (or different input signals) to the desired output signal.

Signal amplification

If long lines or high burdens have to be operated, it may be necessary to amplify the signal. CC analog signal converters require only low input power and provide high output power.

Thus, there are no restrictions for the converter's position on the line, i.e. it can be used

- for signal refreshing ① at the end of the line (low input power)
- or for signal amplification ② at the beginning of the line (high output power).

Signal filtering

Particularly on long lines or in rough industrial environments the signals are exposed to high electromagnetic interferences. The frequency of the coupled interference signals may be in the range of the common mains frequency (50 Hz) or even much higher (in case of frequency converters). According to the specific requirements, analog signal converters are available which provide reliable suppression of those interferences by means of an input low-pass filter.

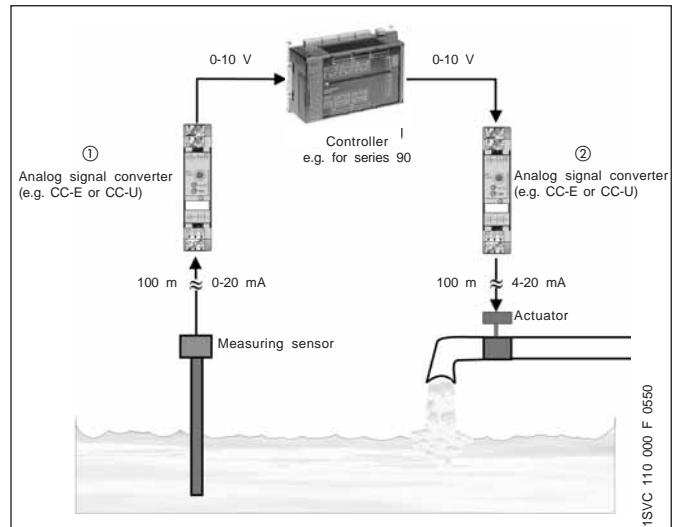

Signal separation

- Protection against overvoltage

The increased use of micro-electronics make controls much more sensitive against overvoltages, resulting from lightning discharges or switching processes. Suppression diodes are incorporated in the input of the CC analog signal converters which enable the converters to arrest overvoltages with low energy level (resulting from switching processes) by themselves. The products furthermore provide electrical isolation between input, output and supply circuit for protection of the controller connected to the output.
- Protection against ground loops

If components are used which refer to ground, the measuring signals can be falsified by a so-called ground loop. In this case, certain parts of the signal are transmitted via earth and not via the analog transmission line, thus causing incorrect evaluation of the signal. The electrical isolation between the input and the output disconnects these ground loops and thus enables correct signal transmission.

- all devices
- specific devices

Approvals	CC-E/STD	CC-U/STD	CC-U/STDR	CC-E/RTD	CC-U/RTD	CC-U/RTDR	CC-E/TC	CC-U/TC	CC-U/TCR	CC-E/I	CC-E I _{ac} / ILPO	CC-U/I	CC-U/W				
UL 508	■	■	■	■	■	■	■	■	■	■	■	■	■				
1604 class 1, div. 2 (hazardous locations)	■	■		■	■		■	■		■		■	■				
C-Tick	■	■	■	■	■	■	■	■	■	■	■	■	■				



Analog standard signal converters

CC-E/STD, C-E x/x

Ordering details

2CDC 281 001 F 0003



CC-E/STD

- ① Gain adjustment
- ② Offset adjustment
- ③ U: green LED - supply voltage
- ④ DIP switch for input and output configuration (only available on universal devices)

CC-E/STD analog signal converter with 3-way electrical isolation

- Universally configurable device (type E-STD)
- 10 single-function devices
- "Plug and Play", no adjustment of single-function devices required
- Approvals , ¹⁾,

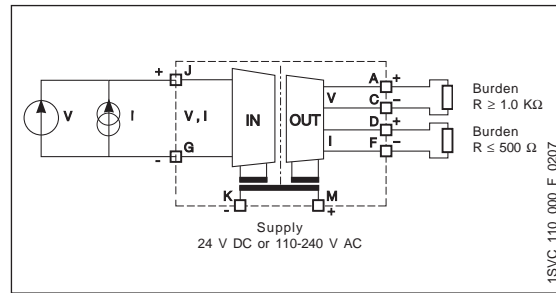

DIP switch settings

Input	Output	Switch							
		1	2	3	4	5	6	7	8
0...5V	0...5V								
0...5V	0...10V								
0...5V	0...20mA								
0...5V	4...20mA								
0...10V	0...5V								
0...10V	0...10V								
0...10V	0...20mA								
0...10V	4...20mA								
0...20mA	0...5V								
0...20mA	0...10V								
0...20mA	0...20mA								
0...20mA	4...20mA								
4...20mA	0...5V								
4...20mA	0...10V								
4...20mA	0...20mA								
4...20mA	4...20mA								

Legend: ON, OFF

Type	Input signal	Output signal	Order code	Price 1 piece
------	--------------	---------------	------------	---------------

Supply voltage: 24 V DC
universal

CC-E/STD	0-5 V, 0-10 V 0-20 mA, 4-20 mA	0-5 V, 0-10 V 0-20 mA, 4-20 mA	1SVR 011 700 R 0000 ¹⁾	
----------	-----------------------------------	-----------------------------------	-----------------------------------	--

single-function

CC-E V/V		0-10 V	1SVR 011 710 R 2100	
CC-E V/I	0-10 V	0-20 mA	1SVR 011 711 R 1600	
CC-E V/I		4-20 mA	1SVR 011 712 R 1700	
CC-E I/V		0-10 V	1SVR 011 713 R 1000	
CC-E I/I	0-20 mA	0-20 mA	1SVR 011 714 R 1100	
CC-E I/I		4-20 mA	1SVR 011 715 R 1200	
CC-E I/V		0-10 V	1SVR 011 716 R 1300	
CC-E I/I	4-20 mA	0-20 mA	1SVR 011 717 R 1400	
CC-E I/I		4-20 mA	1SVR 011 718 R 2500	
CC-E V/V	-10...+10 V	-10...+10 V	1SVR 011 719 R 2600	

Supply voltage: 110-240 V AC
universal

CC-E/STD	0-5 V, 0-10 V 0-20 mA, 4-20 mA	0-5 V, 0-10 V 0-20 mA, 4-20 mA	1SVR 011 705 R 2100	
----------	-----------------------------------	-----------------------------------	---------------------	--

single-function

CC-E V/V		0-10 V	1SVR 011 720 R 2300	
CC-E V/I	0-10 V	0-20 mA	1SVR 011 721 R 1000	
CC-E V/I		4-20 mA	1SVR 011 722 R 1100	
CC-E I/V		0-10 V	1SVR 011 723 R 1200	
CC-E I/I	0-20 mA	0-20 mA	1SVR 011 724 R 1300	
CC-E I/I		4-20 mA	1SVR 011 725 R 1400	
CC-E I/V		0-10 V	1SVR 011 726 R 1500	
CC-E I/I	4-20 mA	0-20 mA	1SVR 011 727 R 1600	
CC-E I/I		4-20 mA	1SVR 011 728 R 2700	
CC-E V/V	-10...+10 V	-10...+10 V	1SVR 011 729 R 2000	

Pack. units: 1 piece

• Technical data 168 • Dimensional drawings 173

Analog standard signal converter CC-U/STD

Ordering details

2CDC 281 002 F0003

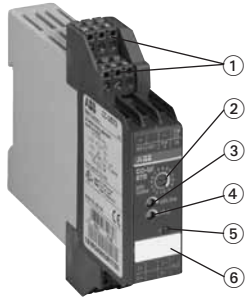

CC-U/STD

- ① Plug-in terminals
- ② Gain: Coarse adjustment
- ③ Gain: Fine adjustment
- ④ Offset adjustment
- ⑤ U: green LED - supply voltage
- ⑥ Marker

CC-U/STD universal signal converter with 3-way electrical isolation

- More than 120 configurations possible
- Configurable output signal response on input signal interruption (low fail safe / high fail safe)
- Adjustment and operating elements on the front-side
- Short-circuit proof signal outputs
- Plug-in connecting terminals for inputs, outputs and supply
- Very fast signal transmission enables use in control systems

■ Approvals   1604 class I, div. 2, 

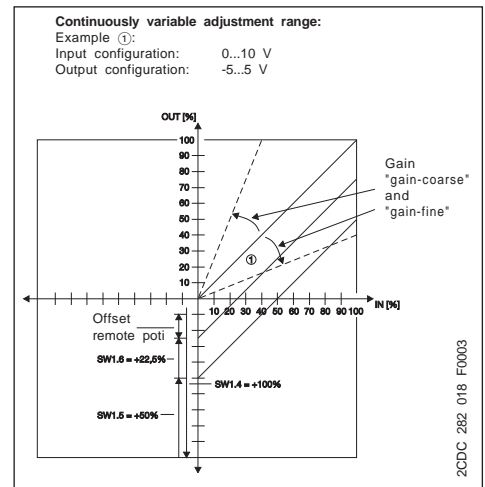
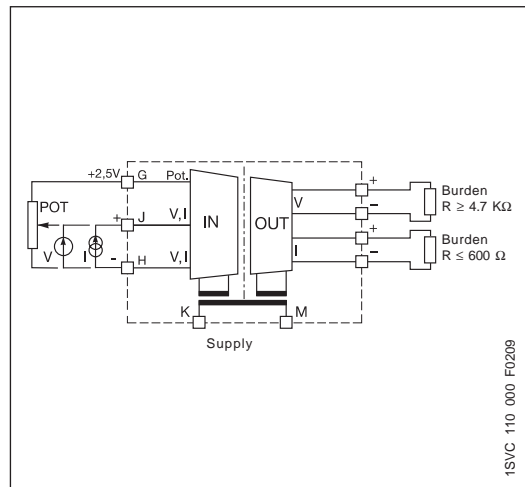



DIP switch settings

Input	SW1								Gain	Coarse Type
	1	2	3	4	5	6	7	8		
Potentiometer									A...D	C
0...50 mV									A...D	C
0...100 mV									4...5	5
0...250 mV									0...1	1
0...500 mV									7...9	8
0...1 V									3...4	3
0...2.5 V									0	0
0...5 V									5...7	6
0...10 V									2	2
1...5 V									7...9	8
2...10 V									2...4	3
-10...+10 V									0	0
0...125 mV									3...4	3
0...8 V									3...4	3
-22.5...+22.5 mV									B...F	D
-11...+11 V									0	0
2.5...7.5 V									5...7	6
3.33...9.99 V									3...4	4
10...0 V									2	2
100...0 mV									4...5	5
0...1 mA									A...D	B
0...20 mA									2...4	3
4...20 mA									4...5	4
10...50 mA									0...1	1
20...4 mA									4...5	4
20...0 mA									4...2	3
-0.45...+0.45 mA									B...F	D
-55...+55 mA									4...6	5
High fail safe *)									-	-
Low fail safe *)									-	-
No fail safe *)									-	-

*) Detection of input signal interruptions:

If the input signal circuit is interrupted, the output signal changes to the adjusted minimum value (low fail safe) or maximum value (high fail safe). If "No fail safe" is configured, input signal interruptions are not detected.

Output	SW2					
	1	2	3	4	5	6
0...5 V						
0...10 V						
1...5 V						
2...10 V						
-10...+10 V						
-5...+5 V						
-10...0 V						
-5...0 V						
0...6.66 V						
-10...3.33 V						
-5...1.66 V						
0...8 V						
0...4 V						
-10...-2 V						
-5...-1 V						
1.25...6.25 V						
-7.5...-2.5 V						
-3.75...1.25 V						
1.66...8.33 V						
-6.66...-6.66 V						
-3.33...-3.33 V						
-8...0 V						
-4...0 V						
0...1 mA						
0...20 mA						
4...20 mA						
0...10 mA						
0...0.5 mA						
0...13.33 mA						
0...666 µA						
0...16 mA						
0...800 µA						
0...8 mA						
0...400 µA						
2.5...12.5 mA						
125...625 µA						
3.33...16.66 mA						
166...833 µA						
0.2...1 mA						
2...10 mA						
100...500 µA						

Legend
 ON
 OFF
 no influence

Type	Supply voltage 50/60 Hz	Order code	Pack. unit pieces	Price 1 piece
CC-U/STD	24-48 V DC / 24 V AC 110-240 V AC / 100-300 V DC	1SVR 040 000 R 1700	1	
		1SVR 040 001 R 0400	1	

• Technical data 170 • Dimensional drawings 173

Analog standard signal converter CC-U/STDR with relay output

Ordering details

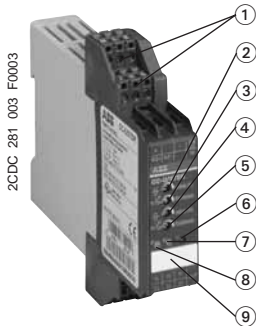

CC-U/STDR

- ① Plug-in connecting terminals
- ② Threshold value for R1
- ③ Hysteresis for R1
- ④ Threshold value for R2
- ⑤ Hysteresis for R2
- ⑥ U: green LED - supply voltage
- ⑦ R2: yellow LED - Relay 2 energized
- ⑧ R1: yellow LED - Relay 1 energized
- ⑨ Marker

CC-U/STDR universal signal converter for standard signals, with 2 threshold relay outputs and with 3-way electrical isolation

- Standard signal converter with 7 setting ranges
- 2 threshold relay outputs with one c/o contact each (threshold and respective hysteresis can be adjusted independently from each other)
- Open-circuit or closed-circuit principle configurable by means of a DIP switch
- 2 yellow LEDs for clear status indication of the output relays
- Plug-in connecting terminals for inputs, outputs and supply

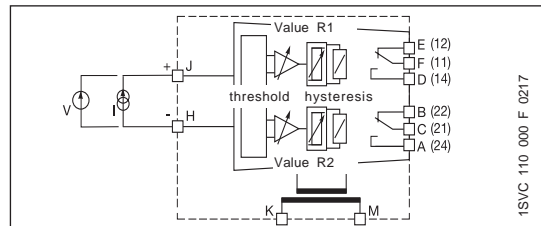

DIP switch settings

Input	SW1					
	1	2	3	4	5	6
0 ... 10 V						
0 ... 5 V	■					
0 ... 1 V		■				
-10 ... +10 V			■			
1 ... 5 V				■		
0 ... 20 mA					■	
4 ... 20 mA						■
Closed-circuit principle	■	■	■	■	■	■
Open-circuit principle	■	■	■	■	■	■

Legend:
 ■ ON
 □ OFF
 ■ no influence

Functional diagrams CC-U/STDR

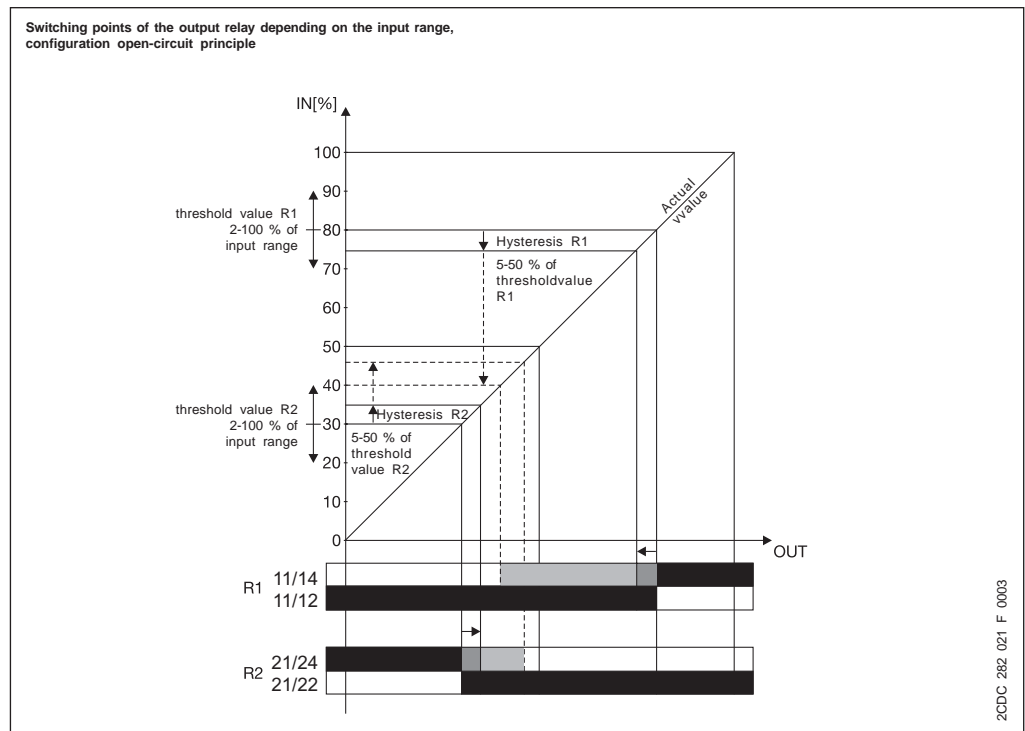
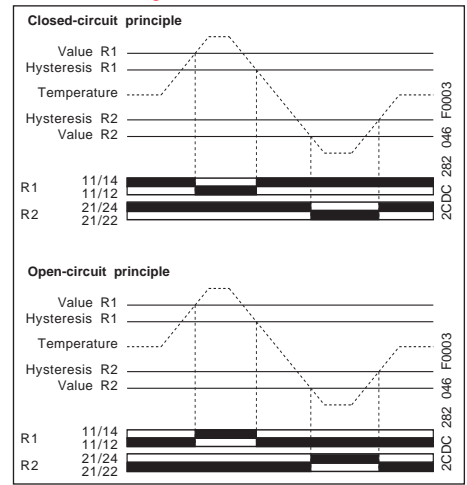

Type	Supply voltage 50/60 Hz	Order code	Pack. unit pieces	Price 1 piece
CC-U/STDR	24-48 V DC / 24 V AC	1SVR 040 010 R 0000	1	
	110-240 V AC / 100-300 V DC	1SVR 040 011 R 2500	1	

• Technical data 172 • Dimensional drawings 173



Temperature signal converter for RTD sensors CC-E/RTD Ordering details

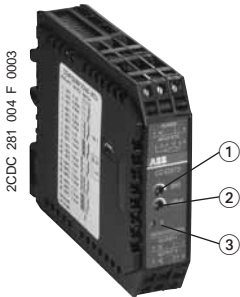

CC-E/RTD

- ① Gain adjustment
- ② Offset adjustment
- ③ U: green LED - supply voltage

CC-E/RTD temperature signal converter for RTD sensors, linearized with 3-way electrical isolation

- Universally configurable device (type E-RTD)
- 12 single-function devices
- "Plug and Play", no adjustment of single-function devices required
- Temperature signal converter for PT100 sensors
- 2- or 3-wire connection

■ Approvals , ¹⁾,

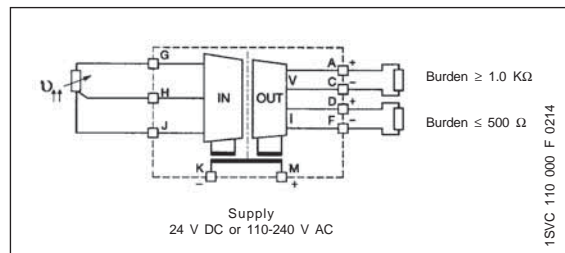

Input	Output	SW 1					
		1	2	3	4	5	6
0 - 100°C	0 - 10 V						
0 - 100°C	0 - 20 mA						
0 - 100°C	4 - 20 mA						
0 - 300°C	0 - 10 V						
0 - 300°C	0 - 20 mA						
0 - 300°C	4 - 20 mA						
0 - 500°C	0 - 10 V						
0 - 500°C	0 - 20 mA						
0 - 500°C	4 - 20 mA						
-50 - 150°C	0 - 10 V						
-50 - 150°C	0 - 20 mA						
-50 - 150°C	4 - 20 mA						
-50 - 250°C	0 - 10 V						
-50 - 250°C	0 - 20 mA						
-50 - 250°C	4 - 20 mA						
-50 - 350°C	0 - 10 V						
-50 - 350°C	0 - 20 mA						
-50 - 350°C	4 - 20 mA						
High bit rate							
Low bit rate							

Type	Input signal	Output signal	Order code	Price 1 piece
------	--------------	---------------	------------	---------------

Supply voltage: 24 V DC
universal

Type	Input signal	Output signal	Order code	Price 1 piece
CC-E/RTD	refer to table	0-10 V, 0-20 mA, 4-20 mA	1SVR 011 701 R 2500 ¹⁾	
single-function				
CC-E RTD/V	PT100 0...100 °C	0-10 V	1SVR 011 730 R 2500	
CC-E RTD/I		0-20 mA	1SVR 011 731 R 1200	
CC-E RTD/I		4-20 mA	1SVR 011 732 R 1300	
CC-E RTD/V	PT100 -50...+50 °C	0-10 V	1SVR 011 733 R 1400	
CC-E RTD/I		0-20 mA	1SVR 011 734 R 1500	
CC-E RTD/I		4-20 mA	1SVR 011 735 R 1600	
CC-E RTD/V	PT100 0...300 °C	0-10 V	1SVR 011 736 R 1700	
CC-E RTD/I		0-20 mA	1SVR 011 737 R 1000	
CC-E RTD/I		4-20 mA	1SVR 011 738 R 2100	
CC-E RTD/V	PT100 -50...+250 °C	0-10 V	1SVR 011 739 R 2200	
CC-E RTD/I		0-20 mA	1SVR 011 740 R 0700	
CC-E RTD/I		4-20 mA	1SVR 011 741 R 2400	

Supply voltage: 110-240 V AC
universal

Type	Input signal	Output signal	Order code	Price 1 piece
CC-E/RTD	refer to table	0-10 V, 0-20 mA, 4-20 mA	1SVR 011 706 R 2200	
single-function				
CC-E RTD/V	PT100 0...100 °C	0-10 V	1SVR 011 788 R 2400	
CC-E RTD/I		0-20 mA	1SVR 011 789 R 2500	
CC-E RTD/I		4-20 mA	1SVR 011 790 R 2200	
CC-E RTD/V	PT100 -50...+50 °C	0-10 V	1SVR 011 791 R 1700	
CC-E RTD/I		0-20 mA	1SVR 011 792 R 1000	
CC-E RTD/I		4-20 mA	1SVR 011 793 R 1100	
CC-E RTD/V	PT100 0...300 °C	0-10 V	1SVR 011 794 R 1200	
CC-E RTD/I		0-20 mA	1SVR 011 795 R 1300	
CC-E RTD/I		4-20 mA	1SVR 011 796 R 1400	
CC-E RTD/V	PT100 -50...+250 °C	0-10 V	1SVR 011 797 R 1500	
CC-E RTD/I		0-20 mA	1SVR 011 798 R 2600	
CC-E RTD/I		4-20 mA	1SVR 011 799 R 2700	

Pack. units: 1 piece

• Technical data 168 • Dimensional drawings 173

Temperature signal converter for RTD sensors CC-U/RTD

Ordering details

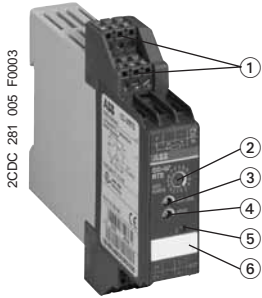

CC-U/RTD

- ① Plug-in connecting terminals
- ② Gain: Coarse adjustment
- ③ Gain: Fine adjustment
- ④ Offset adjustment
- ⑤ U: green LED - supply voltage
- ⑥ Marker

CC-U/RTD universal signal converter for PT10, PT100, PT1000 temperature sensors (acc. to IEC 751 and JIS C 1604*), linearized with 3-way electrical isolation

- Configurable output signal response on input signal interruption (low fail safe / high fail safe)
- Adjustment and operating elements on the front-side
- Short-circuit proof signal outputs
- Plug-in connecting terminals for inputs, outputs and supply
- Approvals

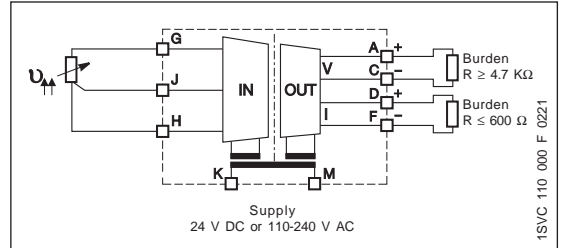

UL US, UL 1604 class I, div. 2, CE

) Japanese standard

Characteristic curves: Resistance of PT10, PT100 and PT1000 sensors depending on the temperature

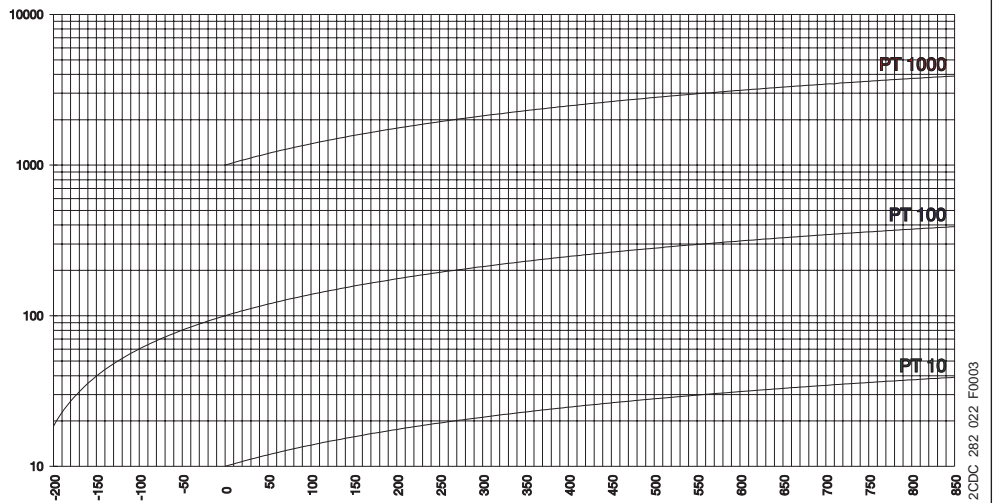

DIP switch settings

Input	SW1						SW2						Gain coarse
	1	2	3	4	5	6	1	2	3	4	5	6	
PT 10	0...500°C	■						■	■	■	■	■	F
	0...550°C	■						■	■	■	■	■	E
	0...600°C	■						■	■	■	■	■	D
	0...650°C	■						■	■	■	■	■	C
	0...700°C	■						■	■	■	■	■	B
	0...750°C	■						■	■	■	■	■	A
PT 100	0...800°C	■						■	■	■	■	■	9
	0...850°C	■						■	■	■	■	8	
	0...50°C	■						■	■	■	■	F	
	0...60°C	■						■	■	■	■	E	
	0...70°C	■						■	■	■	■	B	
	0...80°C	■						■	■	■	■	A	
PT 1000	0...90°C	■						■	■	■	■	9	
	0...100°C	■						■	■	■	■	8	
	0...200°C	■						■	■	■	■	3	
	0...300°C	■						■	■	■	■	2	
	0...400°C	■						■	■	■	■	1	
	0...500°C	■						■	■	■	■	0	
0...10°C	■						■	■	■	■	8		
0...20°C	■						■	■	■	■	3		
0...30°C	■						■	■	■	■	2		
0...40°C	■						■	■	■	■	1		
0...50°C	■						■	■	■	■	0		
0...60°C	■						■	■	■	■	0		
0...6°C	■						■	■	■	■	F		
Low fail safe*)	■						■	■	■	■	-		
High fail safe*)	■						■	■	■	■	-		

*) Detection of input signal interruptions:
If the input signal circuit is interrupted, the output signal changes to the adjusted minimum value (low fail safe) or maximum value (high fail safe).

Output	SW3					
	1	2	3	4	5	6
0...5 V						
0...10 V						
1...5 V	■					
2...10 V	■					
-10...+10 V						
-5...+5 V						
-10...0 V						
-5...0 V						
0...6.66 V						
-10...3.33 V						
-5...1.66 V						
0...8 V						
0...4 V						
-10...-2 V						
-5...-1 V						
1.25...6.25 V						
-7.5...-2.5 V						
-3.75...-1.25 V						
1.66...8.33 V						
-6.66...-6.66 V						
-3.33...-3.33 V						
-8...0 V						
-4...0 V						
0...1 mA						
0...20 mA						
4...20 mA						
0...10 mA						
0...0.5 mA						
0...13.33 mA						
0...666 µA						
0...16 mA						
0...800 µA						
0...8 mA						
0...400 µA						
2.5...12.5 mA						
125...625 µA						
3.33...16.65 mA						
166...833 µA						
0.2...1 mA						
2...10 mA						
100...500 µA						

Legend
 ■ ON
 □ OFF
 ■ no influence

Type	Supply voltage 50/60 Hz	Order code	Pack. unit pieces	Price 1 piece
CC-U/RTD	24-48 V DC / 24 V AC 110-240 V AC / 100-300 V DC	1SVR 040 002 R 0500 1SVR 040 003 R 0600	1 1	

• Technical data 170 • Dimensional drawings 173

Temperature signal converter for RTD sensors CC-U/RTDR with relay output Ordering details

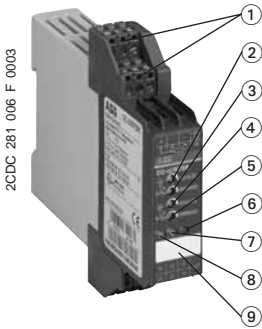

CC-U/RTDR

- ① Plug-in connecting terminals
- ② Threshold value for R1
- ③ Hysteresis for R1
- ④ Threshold value for R2
- ⑤ Hysteresis for R2
- ⑥ U: green LED - supply voltage
- ⑦ R2: yellow LED - Relay 2 energized
- ⑧ R1: yellow LED - Relay 1 energized
- ⑨ Marker

CC-U/RTDR universal signal converter for temperature and resistance signals, with 2 threshold relay outputs and 3-way electrical isolation

- Temperature signal converter for PT100 signals (5 ranges up to 800 °C) and variable resistances from 0-380 Ω
- 2 threshold relay outputs with one c/o contact each (threshold and respective hysteresis can be adjusted independently from each other)
- Open-circuit or closed-circuit principle configurable by means of a DIP switch
- 2 yellow LEDs for clear status indication of the output relays
- Plug-in connecting terminals for inputs, outputs and supply
- Approvals 

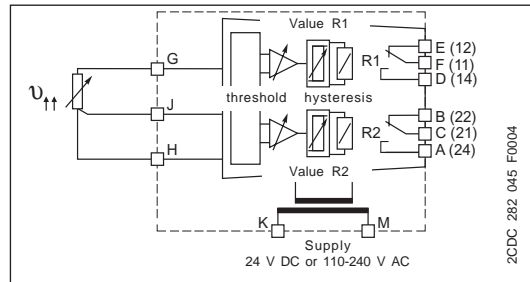

DIP switch settings

Input PT100	SW1					
	1	2	3	4	5	6
0...100 °C	■	■				
0...200 °C	■		■			
0...400 °C			■	■		
0...600 °C				■	■	
0...800 °C					■	■
Closed-circuit principle	■					
Open-circuit principle	■					

Legend
 ■ ON
 □ OFF
 ■ no influence

Functional diagrams CC-U/RTDR

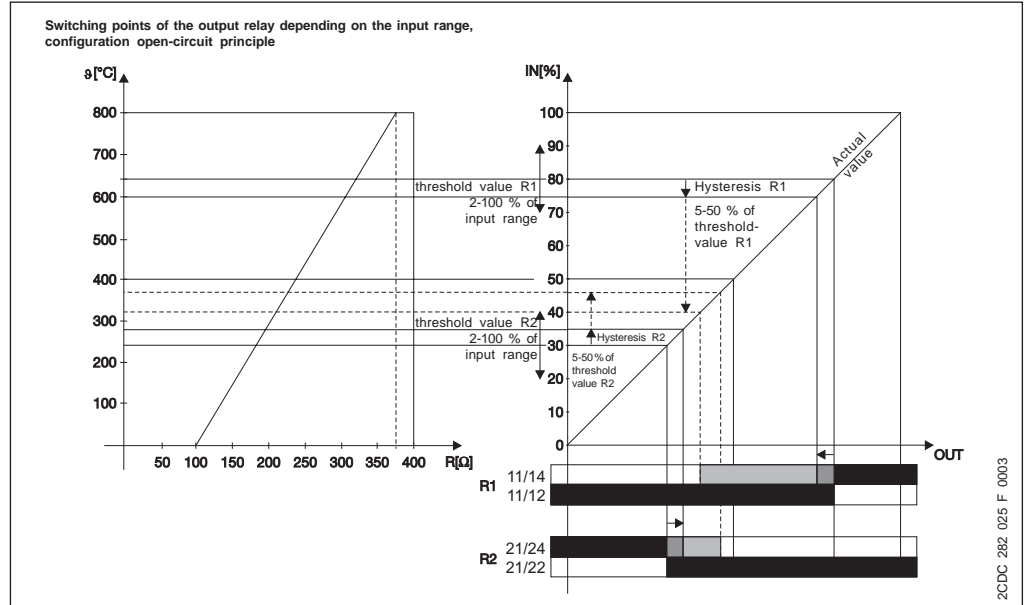
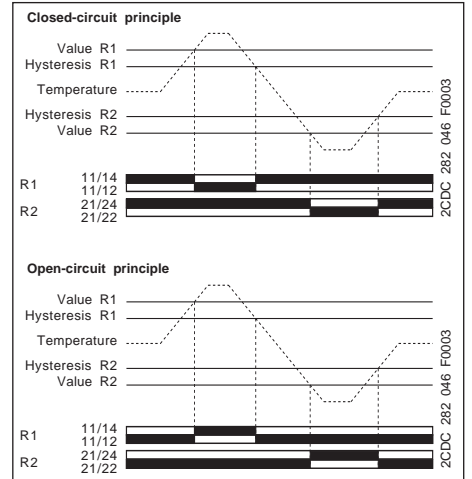

Type	Supply voltage 50/60 Hz	Order code	Pack. unit pieces	Price 1 piece
CC-U/RTDR	24-48 V DC / 24 V AC	1SVR 040 012 R 2600	1	
	110-240 V AC / 100-300 V DC	1SVR 040 013 R 2700	1	

• Technical data 172 • Dimensional drawings 173

Temperature signal converter for thermocouples CC-E/TC

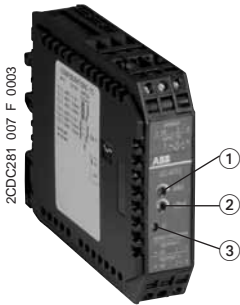

Ordering details



CC-E/TC

- ① Gain adjustment
- ② Offset adjustment
- ③ U: green LED - supply voltage

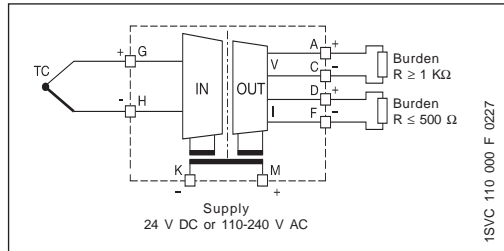

CC-E/TC analog signal converter for thermocouple signals of the types J and K with 3-way electrical isolation

- Universally configurable device (type E/TC)
- 6 single-function devices
- "Plug and Play", no adjustment of single-function devices required
- Approvals   



DIP switch settings

Input	Output	SW1					
		1	2	3	4	5	6
TC-J: 0 ... 600 C	0 ... 10 V						
TC-J: 0 ... 600 C	0 ... 20 mA						
TC-J: 0 ... 600 C	4 ... 20 mA						
TC-K: 0 ... 1000 C	0 ... 10 V						
TC-K: 0 ... 1000 C	0 ... 20 mA						
TC-K: 0 ... 1000 C	4 ... 20 mA						
High fail safe							
Low fail safe							

Legend
 ON
 OFF
 no influence

Type	Input signal	Output signal	Order code	Price 1 piece
------	--------------	---------------	------------	---------------

Supply voltage: 24 V DC
universal

CC-E/TC	thermocouple types J and K	0-10 V, 0-20 mA, 4-20 mA	1SVR 011 702 R 2600 ¹⁾	
single-function				
CC-E TC/V	type J 0-600 °C	0-10 V	1SVR 011 750 R 0100	
CC-E TC/I		0-20 mA	1SVR 011 751 R 2600	
CC-E TC/I		4-20 mA	1SVR 011 752 R 2700	
CC-E TC/V	type K 0-1000 °C	0-10 V	1SVR 011 753 R 2000	
CC-E TC/I		0-20 mA	1SVR 011 754 R 2100	
CC-E TC/I		4-20 mA	1SVR 011 755 R 2200	

Supply voltage: 110-240 V AC
universal

CC-E/TC	thermocouple types J and K	0-10 V, 0-20 mA, 4-20 mA	1SVR 011 707 R 2300	
single-function				
CC-E TC/V	type J 0-600 °C	0-10 V	1SVR 011 760 R 0300	
CC-E TC/I		0-20 mA	1SVR 011 761 R 2000	
CC-E TC/I		4-20 mA	1SVR 011 762 R 2100	
CC-E TC/V	type K 0-1000 °C	0-10 V	1SVR 011 763 R 2200	
CC-E TC/I		0-20 mA	1SVR 011 764 R 2300	
CC-E TC/I		4-20 mA	1SVR 011 765 R 2400	

Pack. units: 1 piece

• Technical data 168 • Dimensional drawings 173

Temperature signal converter for thermocouples CC-U/TC

Ordering details

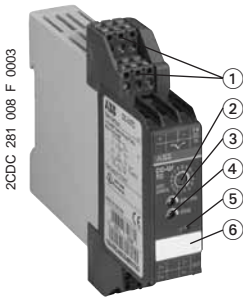

CC-U/TC

- ① Plug-in connecting terminals
- ② Gain: Coarse adjustment
- ③ Gain: Fine adjustment
- ④ Offset adjustment
- ⑤ U: green LED - supply voltage
- ⑥ Marker

CC-U/TC universal signal converter for thermocouples with 3-way electrical isolation

- Temperature signal converter for thermocouples of the types K, J, T, S, E, N, R, B
- Continuously adjustable voltage signal input 0-10 mV and 0-50 mV
- Differential temperature meas. possible ¹⁾
- Configurable output signal response on input signal interruption (low fail safe / high fail safe)
- Adjustment and operating elements on the front-side
- Short-circuit proof signal outputs
- Plug-in connecting terminals for inputs, outputs and supply
- Approvals

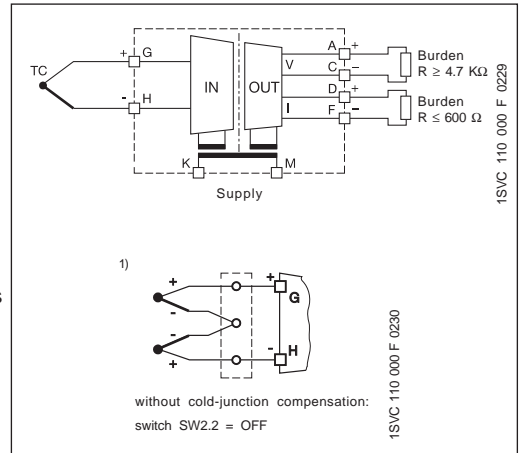
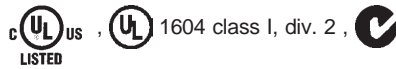

DIP switch settings

Input		SW1						SW2					
Typ	Temperature range	1	2	3	4	5	6	1	2	3	4	5	6
K	0-100...900 °C												
K	0-250...1350 °C												
J	0-100...750 °C												
T	0-100...400 °C												
T	-150...400 °C												
S	0-250...1550 °C												
E	0-100...700 °C												
E	0-200...1000 °C												
N	0-100...650 °C												
N	0-200...1300 °C												
R	0-250...1350 °C												
R	0-450...1700 °C												
B	0-700...1750 °C												
mV	0-2...10 mV												
mV	0-10...50 mV												
LOW FAIL SAFE [*]													
HIGH FAIL SAFE [*]													

Output	SW2					
	1	2	3	4	5	6
0...5 V						
0...10 V						
1...5 V						
-5...10 V						
-10...+10 V						
-5...+5 V						
-10...0 V						
-5...0 V						
0...6,66 V						
-10...3,33 V						
-5...1,66 V						
0...3 V						
0...4 V						
-10...-2 V						
-5...-1 V						
1,25...6,25 V						
-7,5...-2,5 V						
-3,75...-1,25 V						
1,66...8,33 V						
-8,66...-6,66 V						
-3,33...-3,33 V						
-8...0 V						
-1...0 V						
0...1 mA						
0...20 mA						
4...20 mA						
0...10 mA						
0...0,5 mA						
0...13,33 mA						
0...666 µA						
0...16 mA						
0...800 µA						
0...8 mA						
0...400 µA						
2,5...12,5 mA						
125...625 µA						
3,33...16,66 mA						
166...833 µA						
0,2...1 mA						
2...10 mA						
100...500 µA						

^{*} Detection of input signal interruptions:
If the input signal circuit is interrupted, the output signal changes to the adjusted minimum value (low fail safe) or maximum value (high fail safe).

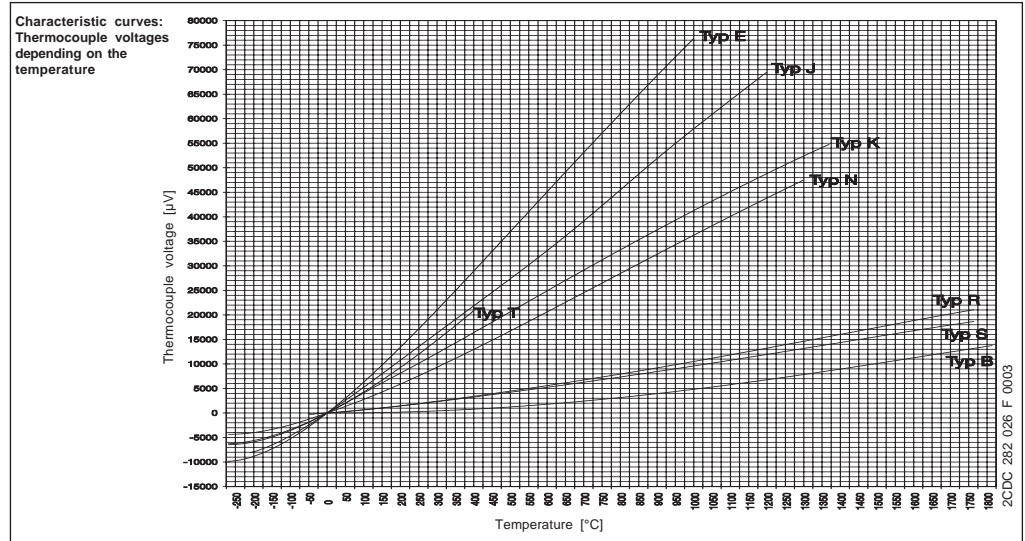

Type	Supply voltage 50/60 Hz	Order code	Pack. unit pieces	Price 1 piece
CC-U/TC	24-48 V DC / 24 V AC 110-240 V AC / 100-300 V DC	1SVR 040 004 R 0700 1SVR 040 005 R 0000	1 1	

• Technical data 170 • Dimensional drawings 173

Temperature signal converter for thermocouples CC-U/TCR with relay output

Ordering details

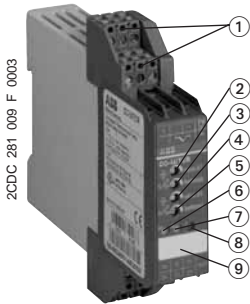

CC-U/TCR

- ① Plug-in connecting terminals
- ② Threshold value for R1
- ③ Hysteresis for R1
- ④ Threshold value for R2
- ⑤ Hysteresis for R2
- ⑥ U: green LED - supply voltage
- ⑦ R2: yellow LED - Relay 2 energized
- ⑧ R1: yellow LED - Relay 1 energized
- ⑨ Marker

CC-U/TCR universal signal converter for thermocouples, with 2 threshold relay outputs and 3-way electrical isolation

- Temperature signal converter for thermocouples of the types K, J, T, S
- 2 threshold relay outputs with one change-over contact each (threshold and respective hysteresis can be adjusted independently from each other)
- Open-circuit or closed-circuit principle configurable by means of a DIP switch
- 2 yellow LEDs for clear status indication of the output relays
- Plug-in connecting terminals for inputs, outputs and supply

Approvals

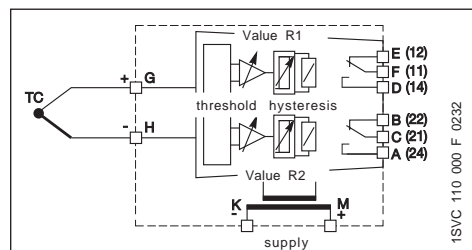

DIP switch settings		SW1					
Typ	Input Temperature range	1	2	3	4	5	6
J	0...240 °C						
J	0...480 °C						
J	0...1200 °C						
K	0...250 °C						
K	0...500 °C						
K	0...1350 °C						
T	-150...+120 °C						
T	0...220 °C						
T	0...400 °C						
S	0...210 °C						
S	0...380 °C						
S	0...860 °C						
S	0...1550 °C						
Closed-circuit principle							
Open-circuit principle							

Legend:
 ON
 OFF
 no influence

Functional diagrams CC-U/TCR

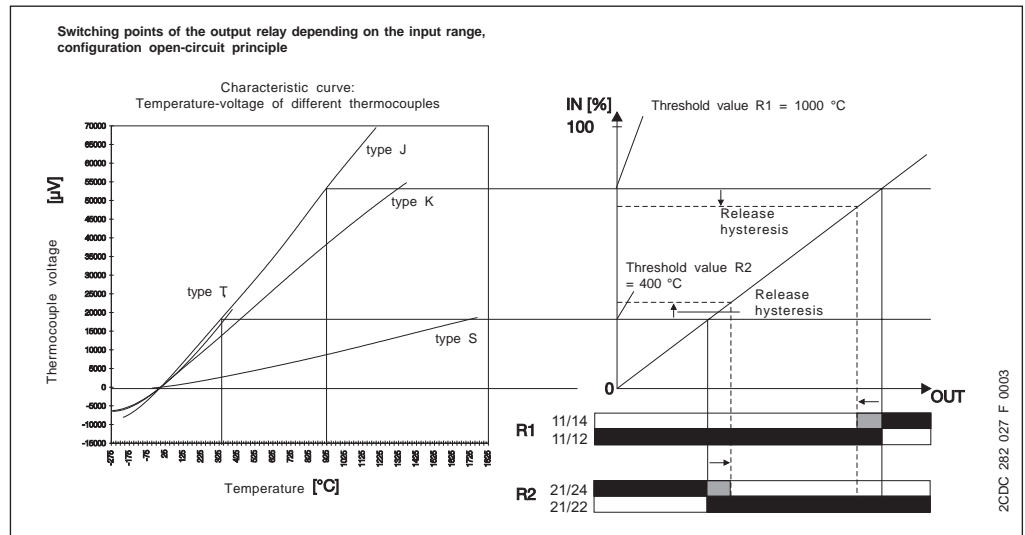
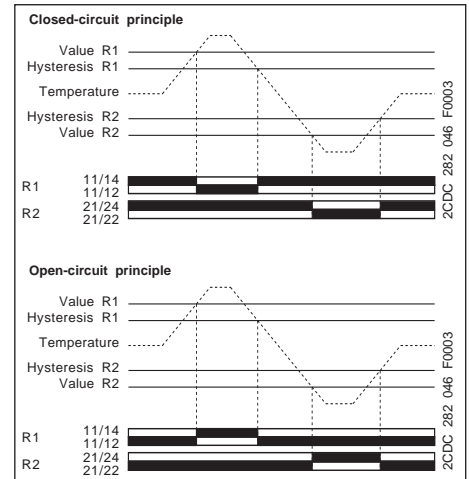

Type	Supply voltage 50/60 Hz	Order code	Pack. unit pieces	Price 1 piece
CC-U/TCR	24-48 V DC / 24 V AC 110-240 V AC / 100-300 V DC	1SVR 040 014 R 2000 1SVR 040 015 R 2100	1 1	

• Technical data 172 • Dimensional drawings 173



Measuring converter for sinusoidal and DC currents CC-E/I Ordering details

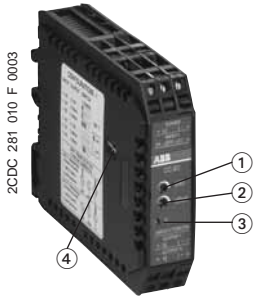

CC-E/I

- ① Gain adjustment
- ② Offset adjustment
- ③ U: green LED - supply voltage
- ④ DIP switch for input and output configuration (only available on universal devices)

CC-E/I current measuring converter for current signals 0-5 A, 0-20 A (AC/DC) with 3-way electrical isolation

- Universally configurable device (type E/I)
- 6 single-function devices
- "Plug and Play", no adjustment of single-function devices required
- Approvals , ¹⁾,

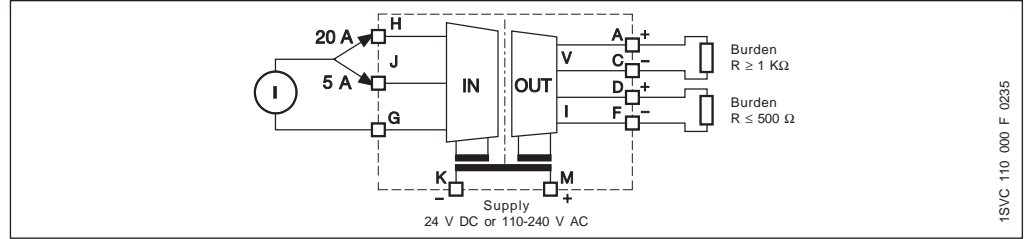

DIP switch settings

Select input range by terminals		
Input range 5 A		
Connected lines		
Used terminals	5 A	20 A
Terminal marking		C
Input range 20 A		
Connected lines		
Used terminals	5 A	20 A
Terminal marking		C

Input	Output	SW1					
		1	2	3	4	5	6
I - DC	0 ... 10 V	■					
I - AC	0 ... 10 V						
I - DC	0 ... 20 mA		■				
I - AC	0 ... 20 mA						
I - DC	4 ... 20 mA	■	■	■			
I - AC	4 ... 20 mA	■	■	■			

Legend: ON, OFF

Type	Input signal	Output signal	Order code	Price 1 piece
------	--------------	---------------	------------	---------------

Supply voltage: 24 V DC
universal

CC-E/I	0-5 A, 0-20 A, AC/DC	0-10 V, 0-20 mA, 4-20 mA	1SVR 011 703 R 2700 ¹⁾	
single-function				
CC-E I _{AC} /V		0-10 V	1SVR 011 770 R 0500	
CC-E I _{AC} /I	0-5 A, 0-20 A, AC	0-20 mA	1SVR 011 771 R 2200	
CC-E I _{AC} /I		4-20 mA	1SVR 011 772 R 2300	
CC-E I _{DC} /V		0-10 V	1SVR 011 773 R 2400	
CC-E I _{DC} /I	0-5 A, 0-20 A, DC	0-20 mA	1SVR 011 774 R 2500	
CC-E I _{DC} /I		4-20 mA	1SVR 011 775 R 2600	

Supply voltage: 110-240 V AC
universal

CC-E/I	0-5 A, 0-20 A, AC/DC	0-10 V, 0-20 mA, 4-20 mA	1SVR 011 708 R 0400	
single-function				
CC-E I _{AC} /V		0-10 V	1SVR 011 780 R 1100	
CC-E I _{AC} /I	0-5 A, 0-20 A, AC	0-20 mA	1SVR 011 781 R 0600	
CC-E I _{AC} /I		4-20 mA	1SVR 011 782 R 0700	
CC-E I _{DC} /V		0-10 V	1SVR 011 783 R 0000	
CC-E I _{DC} /I	0-5 A, 0-20 A, DC	0-20 mA	1SVR 011 784 R 0100	
CC-E I _{DC} /I		4-20 mA	1SVR 011 785 R 1100	

Pack. units: 1 piece

• Technical data 169 • Dimensional drawings 173

Measuring converter for sinusoidal currents

CC-E $I_{AC}/ILPO$

Ordering details

CC-E $I_{AC}/ILPO$ current measuring converter without auxiliary power for sinusoidal currents 0-1 A, 0-5 A, output 4 - 20 mA

- Measuring converter for sinusoidal AC currents (0-1 A, 0-5 A)
- Measuring range selection by front-side slide switch
- 4-20 mA output current in proportion to input current
- no additional power supply required

- Approvals  

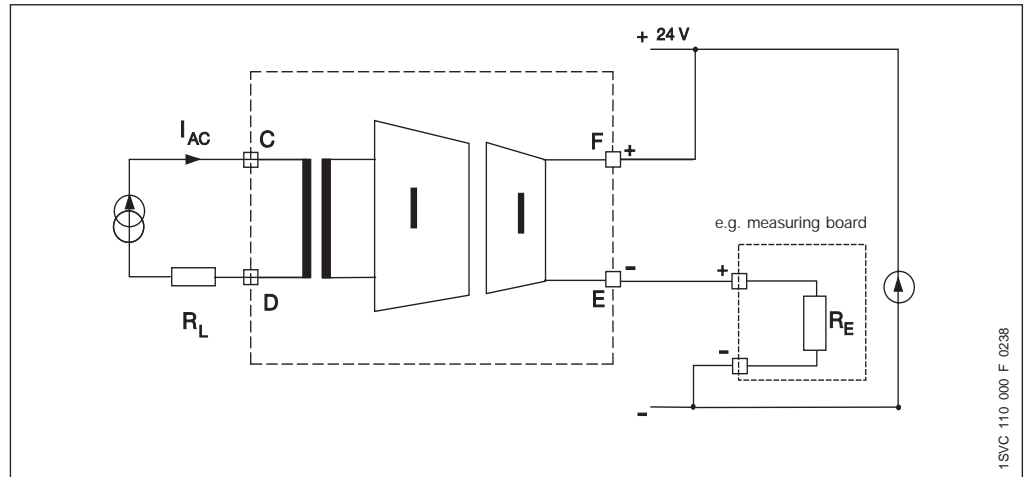

Type	Input signal	Order code	Pack. unit pieces	Price 1 piece
CC-E $I_{AC}/ILPO$	0-1 A, 0-5 A, AC	1SVR 010 203 R 0500	1	

Measuring converter for current RMS values CC-U/I Ordering details

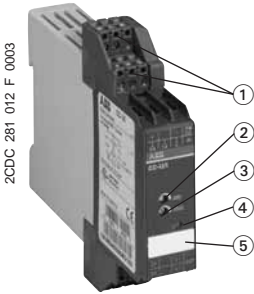

CC-U/I

- ① Plug-in connecting terminals
- ② Gain adjustment
- ③ Offset adjustment
- ④ U: green LED - supply voltage
- ⑤ Marker

CC-U/I universal current measuring converter for RMS values of 0-1 A and 0-5 A, with 3-way electrical isolation

- RMS converter for current signals up to 1 A and up to 5 A of any wave form (DC, DC with superimposed AC components, pure sinusoidal, triangular, phase-angle controlled, etc. in a measuring range of 0-600 Hz)
- Adjustment and operating elements on the front-side
- Short-circuit proof signal outputs
- Plug-in connecting terminals for inputs, outputs and supply
- Approvals , ,

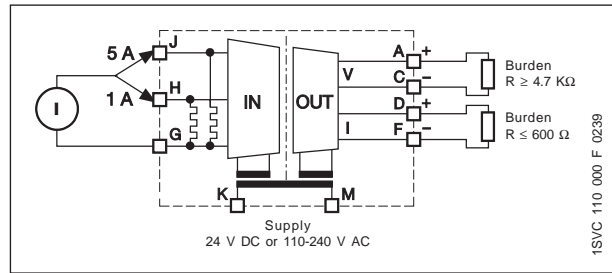

DIP switch settings

Output	SW1					
	1	2	3	4	5	6
0...5 V						
0...10 V						
1...5 V	■					
2...10 V	■					
-10...10 V						
-5...5 V						
-10...0 V						
-5...0 V						
0...6.66 V						
-10...3.33 V						
-5...1.66 V						
0...3 V						
0...4 V						
-10...-2 V						
-5...-1 V						
1.25...6.25 V						
-7.5...-2.5 V						
-3.75...-1.25 V						
1.66...6.33 V						
-6.66...-6.66 V						
-3.33...-3.33 V						
-3...0 V						
-4...0 V						
0...1 mA						
0...20 mA						
4...20 mA						
0...10 mA						
0...0.5 mA						
0...13.33 mA						
0...6.66 μA						
0...16 mA						
0...800 μA						
0...8 mA						
0...400 μA						
2.5...12.5 mA						
125...625 μA						
3.33...16.66 mA						
166...833 μA						
0...1 mA						
0...2 mA						
100...500 μA						

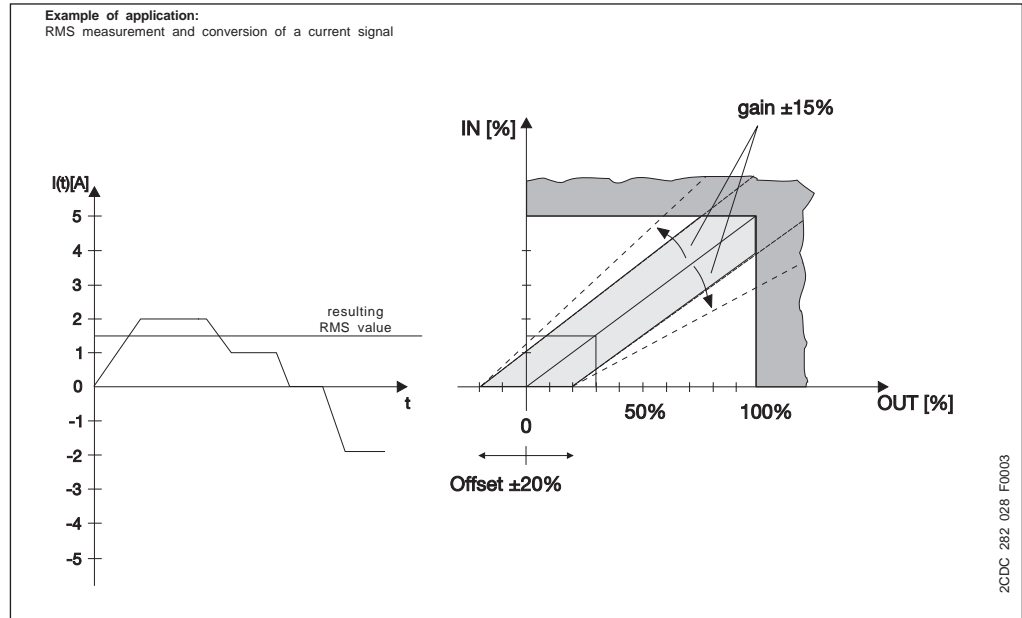
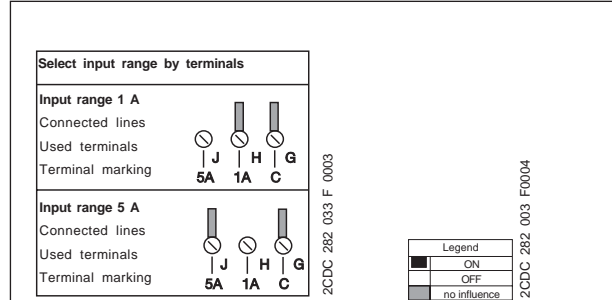

Type	Supply voltage 50/60 Hz	Order code	Pack. unit pieces	Price 1 piece
CC-U/I	24-48 V DC / 24 V AC	1SVR 040 006 R 0100	1	
	110-240 V AC / 100-300 V DC	1SVR 040 007 R 0200	1	

• Technical data 171 • Dimensional drawings 173



Measuring converter for voltage RMS values CC-U/V

Ordering details

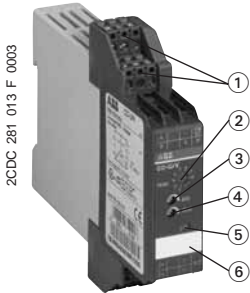

CC-U/V

- ① Plug-in connecting terminals
- ② Input voltage range selection
- ③ Gain adjustment
- ④ Offset adjustment
- ⑤ U: green LED - supply voltage
- ⑥ Marker

CC-U/V universal voltage measuring converter for RMS values of 0-600 V, with 3-way electrical isolation

- RMS converter for voltage signals up to 600 V of any wave form (DC, DC with superimposed AC components, pure sinusoidal, triangular, phase-angle controlled, etc. in a measuring range of 0-600 Hz)
- Adjustment and operating elements on the front-side
- Short-circuit proof signal outputs
- Plug-in connecting terminals for inputs, outputs and supply
- Approvals , ,

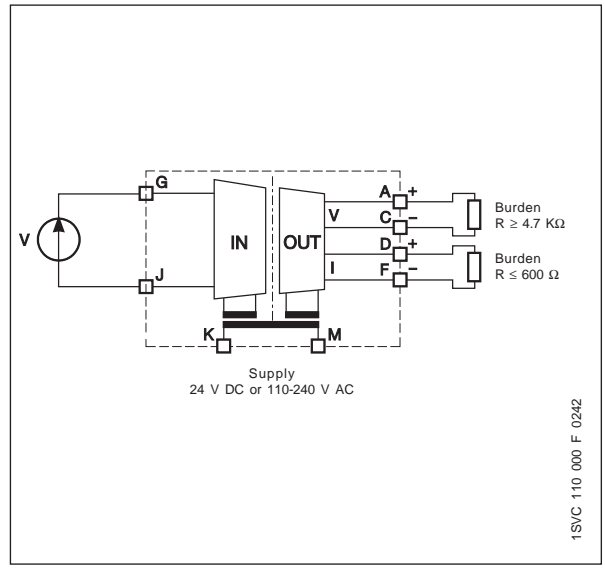

DIP switch settings

Output	SW1					
	1	2	3	4	5	6
0...5 V						
0...10 V						
1...5 V						
2...10 V						
-10...+10 V						
-5...+5 V						
-10...0 V						
-5...0 V						
0...6,66 V						
-10...3,33 V						
-5...1,66 V						
0...8 V						
0...4 V						
-10...-2 V						
-5...-1 V						
1,25...6,25 V						
-7,5...2,5 V						
-3,75...1,25 V						
1,66...8,33 V						
-6,66...6,66 V						
-3,33...3,33 V						
-8...0 V						
-4...0 V						
0...0,1 mA						
0...20 mA						
4...20 mA						
0...10 mA						
0...0,5 mA						
0...13,33 mA						
0...666 μA						
0...16 mA						
0...800 μA						
0...8 mA						
0...400 μA						
2,5...12,5 mA						
125...625 μA						
3,33...16,66 mA						
166...833 μA						
0,2...1 mA						
2...10 mA						
100...500 μA						

Measuring voltage ranges

Selecting input range by front-face rotary switch	Switch position
0...100 V	1
0...150 V	2
0...250 V	3
0...300 V	4
0...400 V	5
0...450 V	6
0...550 V	7
0...600 V	8

Legend	
	ON
	OFF
	no influence

Example of application:

RMS measurement and conversion of a phase-angle controlled voltage signal L1 = 230 V

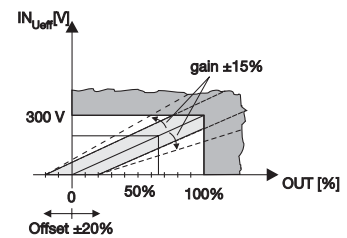
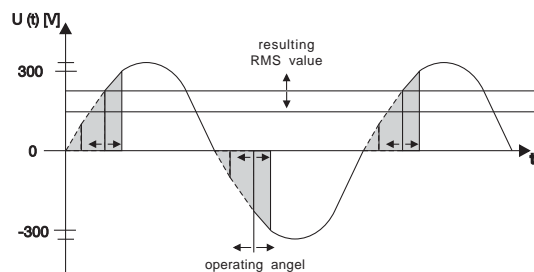

Type	Supply voltage 50/60 Hz	Order code	Pack unit pieces	Price 1 piece
CC-U/V	24-48 V DC / 24 V AC	1SVR 040 008 R 1300	1	
	110-240 V AC / 100-300 V DC	1SVR 040 009 R 1400	1	

• Technical data 171 • Dimensional drawings 173

Analog signal converters

CC-E/STD, CC-E/RTD, CC-E/TC

Technical data

Input circuits J-G-H	CC-E/STD		CC-E/RTD	CC-E/TC
	Current	Voltage	Temperature sensors	Thermocouples (IEC 584-1 and -2)
Input signal	0-20 mA / 4-20 mA	0-5 V / 0-10 V / -10...+10 V	PT100	TC.K, TC.J
Input measuring range			-50 ... +300 °C	TC.K 0-1000 °C, TC.J 0-600 °C
Limitation of input signals	+55 mA	± 11 V		
Influence of line resistance			< 0.01 %/Ω	> 0.5 % / 100 Ω
Gain adjustment range	± 5 % (universal devices)			
Offset adjustment range	± 5 % (universal devices)			
Input impedance	50 Ω	1 mΩ		
Suppression at 50 Hz				> 35 dB
Common-mode rejection			100 dB	
Output circuits D-F A-C	Current		Voltage	
Output signal	0-20 mA, 4-20 mA		0-5 V, 0-10 V	
Output burden	≤ 500 Ω		≥ 1.0 KΩ	
Accuracy	Factory setting		± 0,1 % of full-scale	
	Repeat accuracy ¹⁾		± 0,5 % of full-scale	
Temperature coefficient	± 500 ppm/°C			
Residual ripple	< 0.5 %			
Response time	200 μs		10 ms	
Transmission frequency	2 kHz		80 Hz	2 Hz (up to -3 dB)
Response to input circuit interruption			Low Fail Safe: Output voltage > 15 % of measuring range ²⁾ Low Fail Safe: Output voltage < -0.6 V, output current = 0 mA	
Supply circuits K - M	DC versions		AC versions	
Supply voltage	24 V DC		110-240 V AC - 50/60 Hz	
Supply voltage tolerance	-15 % ... + 15 %		-15 % ... + 10 %	
Power consumption	1.5 W typ.		1.5 VA typ.	
Indication of operational states				
Supply voltage	U: green LED			
Isolation data				
Test voltage between all isolated circuits	2.5 kV AC			
Rated insulation voltage	-		-	-
General data				
Operating temperature	0 °C ... +60 °C			
Storage temperature	-20 °C ... +80 °C			
Degree of protection acc. to DIN 40050	IP20			
Mounting position	ventilation slots on top and bottom			
Mounting on DIN rail	snap-on mounting			
Wire size	solid wire		4 mm ² (10 AWG)	
	stranded wire		2.5 mm ² (14 AWG)	

¹⁾ Constant parameters

²⁾ Only -/RTD and -/TC: Single-function devices respond with LOW FAIL SAFE to input signal interruptions

Analog signal converters

CC-E/I, CC-E I_{AC}/ILPO

Technical data

Input circuits	CC-E/I		CC-E I _{AC} /ILPO
	J-G-H		C-D
	AC cur. meas.	DC cur. meas.	2 meas. ranges selectable
Input signal	0-5 A / 0-20 A	0-5 A / 0-20 A	0-1 A / 0-5 A / sinusoidal
Measuring frequency			50/60 Hz
Overload capacity of inputs	10 x I _{Nom.} for max. 1 s		10 x I _{Nom.} for max. 2 s
Gain adjustment range	± 5 % (univ. devices)		-
Offset adjustment range	± 5 % (univ. devices)		-
Input impedance / resistance	5A = 65 Ω	20 A =2.5 mΩ	5 mΩ
Output circuits	D-F Current	A-C Voltage	F-E passive current output in proportion to input current
Output signal	0-20 mA 4-20 mA	0-10 V	4-20 mA
Output burden / load	≤ 500 Ω	≥ 1.0 Ω	12 V DC - 150 Ω 24 V DC - 750 Ω 30 V DC - 1050 Ω
Accuracy	Factory setting		± 0,1 % of full-scale
	Repeat accuracy ¹⁾		± 2 % of full-scale
Offset adjustment range	-		± 5 %
Gain adjustment range	-		± 20 %
Temperature coefficient	± 500 ppm/°C		300 ppm/°C
Residual ripple	< 0,5 %		-
Response time	0,5 s		-
Transmission frequency	DC or 50/60 Hz		-
Response to circuit interruption	Low Fail Safe: Output voltage < 200 mA, output current < 400 μA		-
Supply circuits K - M	DC Versions	AC Versions	
Supply voltage	24 V DC	110-240 V AC 50/60 Hz	12-30 V DC
Supply voltage tolerance	-15 % ... + 15 %	-15 % ... + 10 %	-
Power consumption	typ 1.5 W	typ 1.5 VA	-
Indication of operational states			
Supply voltage	U: green LED		-
Isolation data			
Test voltage between all isolated circuits	2.5 kV AC		
Rated insulation voltage	-		250 V AC
General data			
Operating temperature	0 °C ... +60 °C		-20 °C ... +60 °C
Storage temperature	-20 °C ... +80 °C		-40 °C ... +80 °C
Degree of protection acc. to DIN 40050	IP20		
Mounting position	ventilation slots on top and bottom		
Mounting on DIN rail	snap-on mounting		
Wire size	solid wire	4 mm ² (10 AWG)	1x2.5 mm ² (14 AWG)
	stranded wire	2.5 mm ² (14 AWG)	

¹⁾ Constant parameters

Analog signal converters

CC-U/STD, CC-U/RTD, CC-U/TC

Technical data

Input circuits J-G-H	CC-U/STD			CC-U/RTD	CC-U/TC
	Current	Voltage	Potentiometer	temperature sensors	Thermocouples (IEC 584-1 and 2)
Input signals	0-20 mA 4-20 mA 10-50 mA 0-1 mA	0-100 mV 0-1 V 0-5 V 1-5 V 0-10 V 2-10 V ± 10 V	470 Ω ... 1 MΩ	PT10, PT100, PT1000 (IEL 751 and JICC 1604)	TC.K TC.J TC.T TC.S TC.E TC.N TC.R TC.B
Limitation of input signals	± 55 mA	± 11 V	10 kΩ	-	-
Temperature range	-	-	-	Max. Temperature adjustable: 6-60 °C for PT1000 50-500 °C for PT100 500-850 °C for PT 10	refer to temperature specs. of individual thermocouples
Influence of line resistance	-	-	-	0.015 °C/Ω	< 0.01 % / 100 Ω
Gain adjustment range (univ. devices)	0.9- 110 mA	45 mV - 22 V	-	-	-
Offset adjustment range (univ. devices)	-137.5 % ... +62.5 %			± 5 %	± 10 %
Input impedance	for different ranges			-	-
without detection of input signal interruption	51 Ω	6 MΩ	3 GΩ	-	-
with detection of input signal interruption	51 Ω	3.5 MΩ	9.5 GΩ	-	-
Suppression at 50 Hz	-	-	-	-	> 40 dB
Common-mode rejection	-	-	-	120 dB	105 dB
Output circuit D-F A-C	Current		Voltage		
Output signals	0-20 mA, 4-20 mA		0-5 V, 1-5 V, 0-10 V, 2-10 V, ±10 V		
Output burden	≤ 600 Ω		≥ 4,7 KΩ		
Accuracy	±0,1 % of full-scale		±0,2 % of full-scale		±0,1 % of full-scale
Temperature coefficient	±150 ppm/°C		±250 ppm/°C		±200 ppm/°C at min offset ±400 ppm/°C at max. offset
Residual ripple	-	-	-	< 0,15 %	-
Response time	200 μs		10 ms		200 ms
Transmission frequency	1 kHz		80 Hz		2 Hz (bis -3 dB)
Supply circuits K - M					
Supply voltage	24-48 V DC / 24 V AC		110-240 V AC / 100-300 V DC		
Supply voltage tolerance	DC: -15 % ... + 15 %		AC: -15 % ... + 10 %		
Power consumption	2 W at 24 V DC		4.5 VA at 230 V AC		
Indication of operational states					
Supply voltage	U: green LED				
Isolation data					
Test voltage between all isolated circuits	1.5 kV				
Electromagnetic compatibility	acc. to EN 61000-6-4, EN 61000-6-2				
General data					
Operating temperature	-20 °C ... +60 °C				
Storage temperature	-40 °C ... +80 °C				
Mounting position	any				
Mounting on DIN rail	snap-on mounting / screw mounting with adapter				
Wire size	solid wire	plug-connector with screw terminals 1.5 mm ² (16 AWG)			
	stranded wire	plug-connector with screw terminals 2.5 mm ² (14 AWG)			

Analog signal converters

CC-U/I, CC-U/V

Technical data

Input circuits J-G-H	CC-U/I any current signals, RMS measurement	CC-U/V any voltage signals, RMS measurement	
Measuring signals	0-1 A 0-5 A	0-100 V, 0-200 V 0-300 V, 0-400 V 0-500 V, 0-600 V	
Measuring frequency	0-600 Hz		
Overload capacity of inputs	10 x I _{Non.} for max. 2 s	-	
Gain adjustment range	±20 %		
Offset adjustment range	±15 %		
Input impedance / resistance	60 mΩ / 12 mΩ	> 800 kΩ	
Output circuits D-F A-C			
	Current	Voltage	
Output signal	0-20 mA, 4-20 mA	0-5 V, 1-5 V, 0-10 V, 2-10 V, ±10 V	
Output load	≤ 600 Ω	≤ 4,7 kΩ	
Accuracy	0,5 %		
Temperature coefficient	±250 ppm/°C max.	±300 ppm/°C max.	
Residual ripple	< 0.15 %		
Response time	150 ms		
Supply circuit K - M			
Supply voltage	24-48 V DC / 24 V AC	110-240 V AC / 100-300 V DC	
Supply voltage tolerance	DC: -15 % ... + 15 %	AC: -15 % ... + 10 %	
Power consumption	2 W at 24 V DC	4.5 VA at 230 V AC	
Indication of operational states			
Supply voltage	U: green LED		
Isolation data			
Test voltage between all isolated circuits	1.5 kV		
Electromagnetic compatibility	acc. to EN 61000-6-4, EN 61000-6-2		
General data			
Operating temperature	-20 °C ... +60 °C		
Storage temperature	-40 °C ... +80 °C		
Mounting position	any		
Mounting on DIN rail (EN 50022)	snap-on mounting / screw mounting with adapter		
Wire size	solid wire	plug-connector with screw terminals 1.5 mm ² (16 AWG)	
	stranded wire	plug-connector with screw terminals 2.5 mm ² (14 AWG)	

Analog signal converters with relay output CC-U/STDR, CC-U/RTDR, CC-U/TCR

Technical data

Input circuits J - H	CC-U/STDR		CC-U/RTDR	CC-U/TCR
	Current	Voltage	Temperature sensors	Thermocouples (IEC 584-1 and -2)
Measuring signal / input range	0-20 / 4-20 mA	0-1 V / 1-5 V / 0-10 / ±10 V	PT100	TC.K, TC.J, TC.T, TC.S
Input burden	50 Ω	> 5 mΩ		
Adjustable threshold	2-100 % of selected input range			
Adjustable hysteresis	5-50 % of threshold			
Accuracy	0.5 %			
Temperature coefficient	±300 ppm/°C			
Output circuits E - D - F, B - C - A			Relay, 2 c/o contacts	
Rated switching voltage	250 V AC			
Rated switching current	AC-12 (resistive) 230 V		4 A	
	AC-15 (inductive) 230 V		3 A	
	DC-12 (resistive) 24 V		4 A	
	DC-13 (inductive) 24V		2 A	
Min. switching voltage	12 V			
Min. switching current	10 mA			
min. switching power	0.6 VA (W)			
Response time	10 ms			
Max. lifetime	mechanical		30 x 10 ⁶ switching cycles	
	electrical (AC-12, 230 V, 4 A)		0.1 Mio. switching cycles	
Supply circuits K - M				
Supply voltage	24-48 V DC / 24 V AC		110-240 V AC / 100-300 V DC	
Supply voltage tolerance	DC: -15 %...+15 %		AC: -15 % ... +10 %	
Power consumption	2 W at 24 V DC		4.5 VA at 230 V AC	
Indication of operational states				
Supply voltage	U: green LED			
1st output relay energized	R1: yellow LED			
2nd output relay energized	R2: yellow LED			
Isolation data				
Insulation voltage between all isolated circuits	1.5 kV			
Electromagnetic compatibility	acc. to EN 61000-6-4, EN 61000-6-2			
General data				
Operating temperature	-20 °C ... +60 °C			
Storage temperature	-40 °C ... +80 °C			
Mounting position	any			
Mounting on DIN rail (EN 50 022)	snap-on mounting / screw mounting with adapter			
Wire	solid wire	plug-connector with screw terminals 1.5 mm ² (16 AWG)		
size	stranded wire	plug-connector with screw terminals 2.5 mm ² (14 AWG)		

Load limit curves

AC load (resistive)

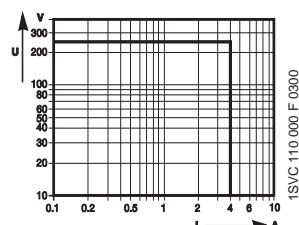

DC load (resistive)

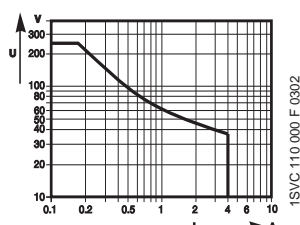

Derating curve

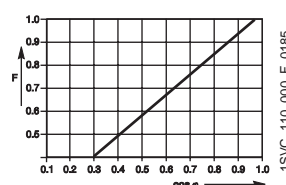

Analog signal converters

CC-E, CC-U

Dimensional drawings, Connecting terminals

Dimensions in mm

CC-E/x

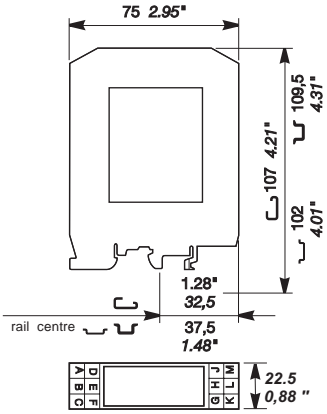

CC-E I_{Ac}/ILPO

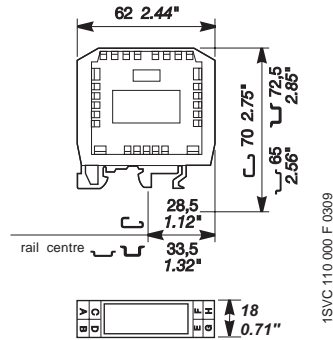

CC-U/x , CC-U/xR

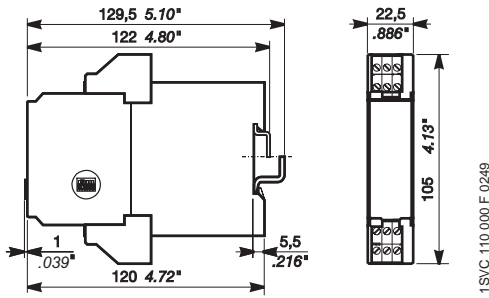

Connecting terminals CC-U/x

Width 22.5 mm / .886 "

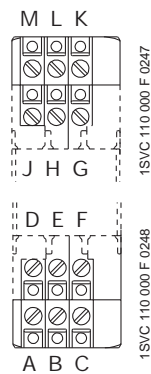

Notes

5

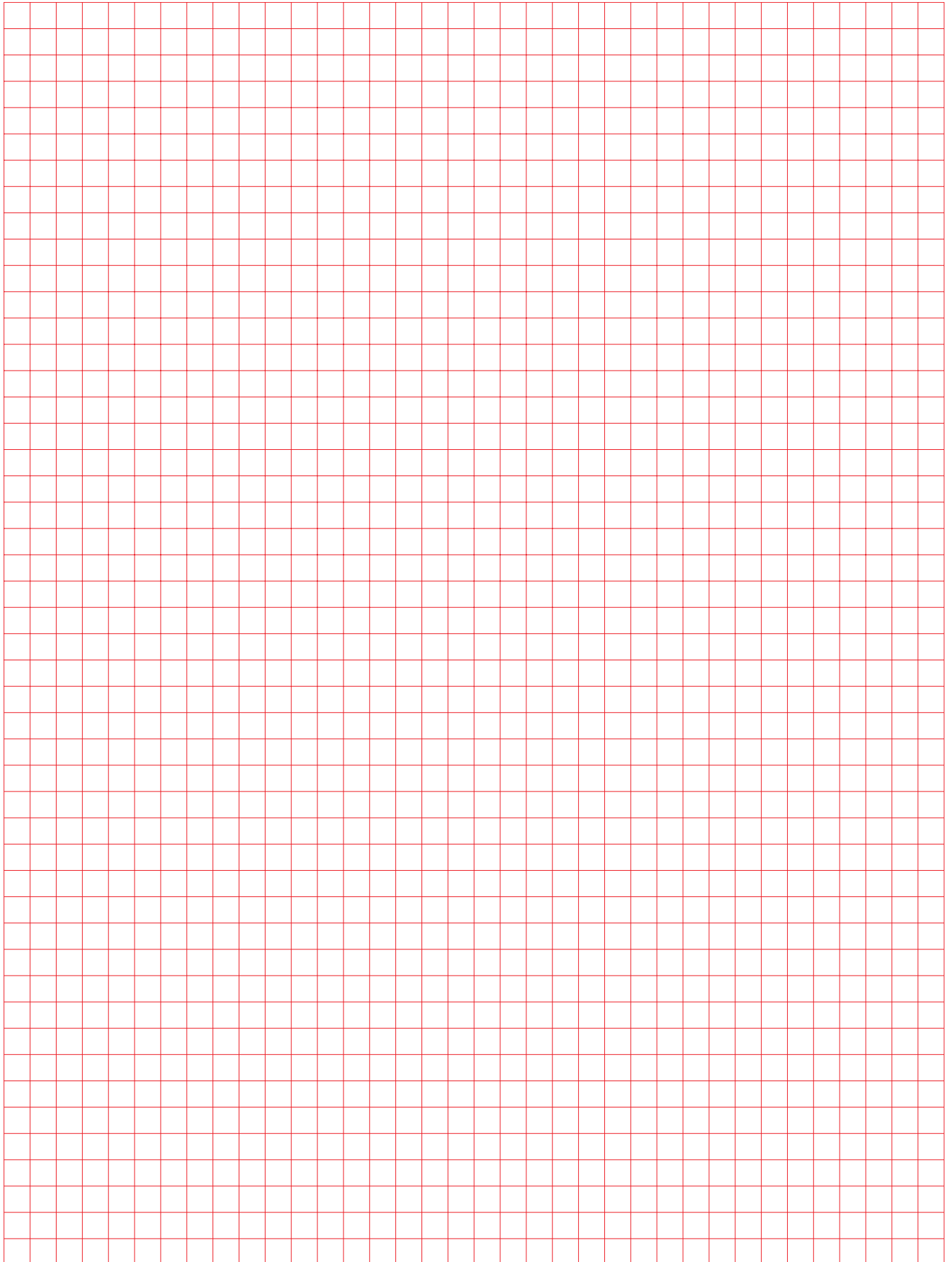



Serial data converters IPLH range

Content

NEW Serial data converters IPLH range	176
--	-----

Serial data converters

In the field of industrial data transmission, various processes of data transmission and interfaces are used today. Thus, the user often feels the need to convert the existing interface into another interface. Simple point to point connections are most often made using the standard RS-232 (V.24), and multipoint with the RS-422 or RS-485 standard, with a current tendency to use optical fiber.

For the conversion of various interfaces, ABB ENTRELEC offers connection interfaces ILPH, a large range of products for industrial use.

Multipoint connections

Some equipments are only designed to communicate in RS232 point to point connection. To communicate with several devices it is then necessary to use converters RS232 to RS422, RS485, BDC or FO to reach multipoint mode.

Type of connection	Connection
RS232	Point to point
RS422	12 points
RS485	32 points
CL	5-6 points
OF	32 points

Example :

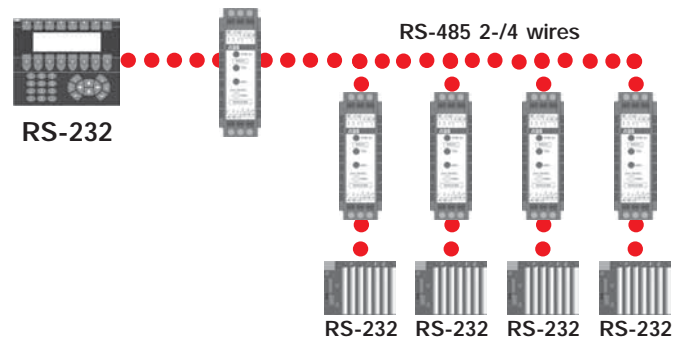

Uses

Adaptation :

The use of converters allows the connection of two devices using Different interfaces.
To add new equipment to existing installations.

Example :

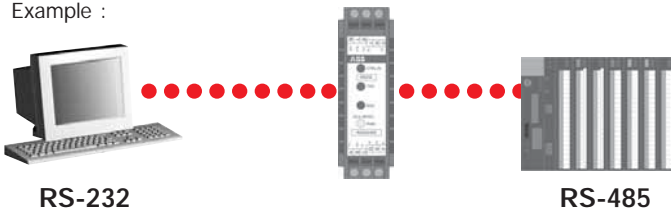

Galvanic Isolation.

To protect sensitive equipment it is sometimes necessary to use converters which allow galvanic isolation.

Example :

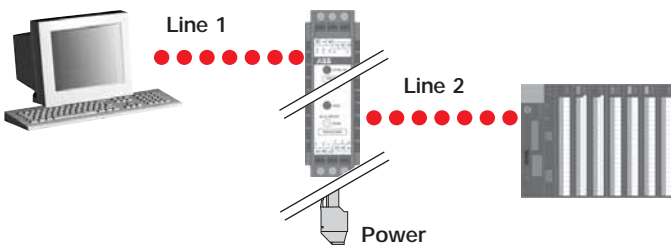

To cross a disturbed environment.

Some interfaces are more sensitive to noise. Electrically, it is preferable, in some cases, to change the interface or support.

Type of connection	Immunity to noise
RS232	Low
RS422	High
RS485	High
CL	High
OF	Very high

Example :

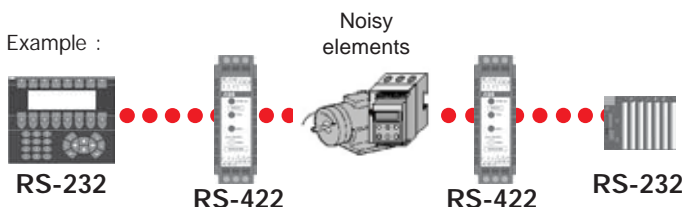

Increase in the transmission and amplification distances from the Signals.

Every connection has its own limits, to increase the communication distances you only have to change the type of link (converter) or amplify the signal (Repeater) using an ILPH.

Type of connection	Max. distances *
RS232	15m
RS422	1.2km
RS485	1.2km
CL	300-500m
OF	4km

* Depending on transmission speed.

Example :

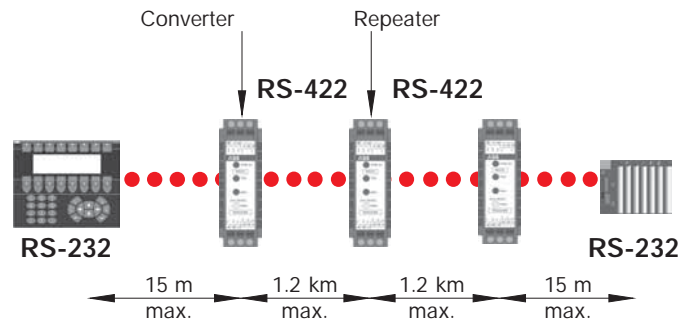

Product overview

	RS232	RS422-485	CL	OF-S	OF-P	24 V DC	24-48 V DC	110-240 V DC	24-42 V AC/DC	Insulation *	New part numbers	Old Entelec part numbers	Old ABB part numbers
RS232	●					●				In-Ps-O	1SNA 684 234 R2000	0084 234.12	
	●						●			In-Ps-O	1SNA 684 244 R0200	0084 244.24	
		●			●					Wi	1SNA 684 231 R2500	0084 231.17	
		●			●					In-O	1SNA 684 233 R2700	0084 233.11	
		●				●				In-Ps-O	1SNA 684 333 R2300	0084 333.15	
		●					●			In-Ps-O	1SNA 684 334 R2400	0084 334.16	
			●		●					In-O	1SNA 684 202 R0100	0084 202.23	
				●				●		In-Ps-O	1SNA 684 236 R2200	0084 236.14	1SVR 084 236 R1400
				●				●		In-Ps-O	1SNA 684 237 R2300	0084 237.15	1SVR 084 237 R1500
					●			●		In-Ps-O	1SNA 684 238 R0400	0084 238.26	1SVR 084 238 R2600
					●			●		In-Ps-O	1SNA 684 239 R0500	0084 239.27	1SVR 084 239 R2700
RS422 / RS485		●			●					In-O	1SNA 684 212 R2200	0084 212.14	
			●		●					In-O	1SNA 684 232 R2600	0084 232.10	
RS485				●			●			In-Ps-O	1SNA 684 246 R0400	0084 246.26	1SVR 084 246 R2600
				●			●			In-Ps-O	1SNA 684 247 R0500	0084 247.27	1SVR 084 247 R2700
				●			●			In-Ps-O	1SNA 684 248 R1600	0084 248.00	1SVR 084 248 R0000
				●			●			In-Ps-O	1SNA 684 249 R1700	0084 249.01	1SVR 084 249 R0100

* In=Input, Ps=Power supply, O=Output, Wi=Without insulation

- **RS 232 - EIA-232 / V.24 / V.28**
Point-to-point connection
Max. 15 m transmission distance
Rate up to 19.2 kbit/s
Full-duplex
- **RS 422 - EIA-422 / V.11**
Point-to-point connection
(1 Transmitter - 10 Receivers)
Differential voltage transmission
Full-duplex
Up to 1200 m/ 10Mbit/s
Good EMC characteristics
- **Current loop(TTY)**
Point-to-point / multi-point connection
Active or passive current loop
Full-duplex
Up to 1200 m/19.2 kBit/s
Good EMC characteristics
- **RS 485 - ISO/IEC/EIA-485**
Multi-point connection up to 32 units
Differential voltage transmission
Half-duplex on 1 pair
Full-duplex on 2 pairs
Up to 1200 m / 10Mbit/s
Good EMC characteristics
- **Optical fiber interface**
Point-to-point connection
Full-duplex
From 40m up to 4km transmission distance according to optical fiber material (plastic / glass) and wavelength used up to 10 Mbit/s
Excellent EMC characteristics

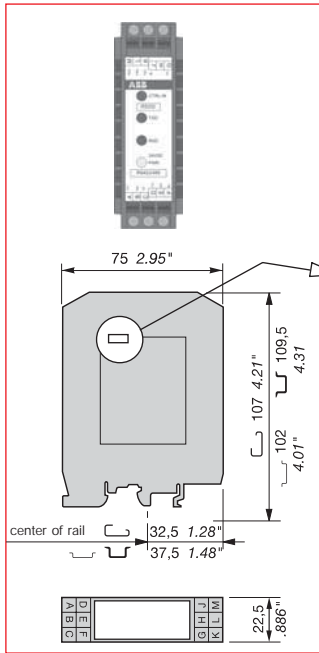

ILPH RS 232 / RS 422 - 485

RS 232 to RS 422-485 serial link without isolation

- Economic version without isolation
- Baudrate up to 38,4 kbit/s
- Transmission distance up to 1200 m
- RS 485 1 or 2 pair handling
- Usable in "noisy" environments
- 24 V DC power supply
- CE mark

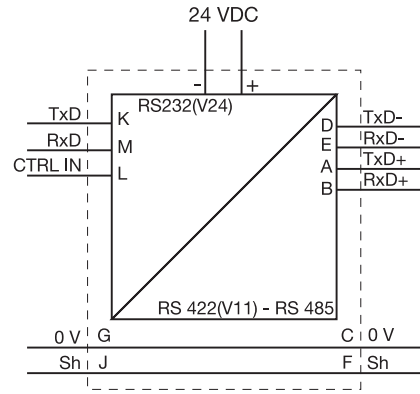

Description	Type	Order P/N	Packaging Weight kg
Serial link interface without galvanic isolation	ILPH RS 232 / RS 422-485	1SNA 684 231 R2500	1 0,1

RS 485 LINK ON ONE PAIR

R		R ON/OFF	Jumper R in position	R ON/OFF
E		E ON/OFF	Jumper E in position	E ON/OFF

The Receiver and the Transmitter are activated alternately (never at the same time) depending on the status of the CTRL IN signal.

CTRL IN STATUS	ACTION ON RS 485
0 logic (+3V ≤ U ≤ +25V)	Transmitter active / Receiver inactive
1 logic (-25V ≤ U ≤ -3V)	Transmitter inactive / Receiver active
High impedance	Transmitter inactive / Receiver active

NOTE : For RS 232 products running the RTS (REQUEST TO SEND) signal, connect RTS to CTRL IN. Otherwise, connect M (RxD ILPH) to L (CTRL IN).

RS 485 LINK ON 2 PAIRS

R		R ON	Jumper R in position	R ON
E		E ON/OFF	Jumper E in position	E ON/OFF

Receiver permanently active
Transmitter controlled by the signal CTRL IN (see table for Transmitter operation as a function of CTRL IN)

RS 422 LINK ON TWO PAIRS

R		R ON	Jumper R in position	R ON
E		E ON	Jumper E in position	E ON

The Transmitter and Receiver are both permanently active.

POLARIZATION OF THE RS 422 - RS 485 LINE

The line must always be polarized. The ILPH is used to polarize the reception channel :
Connection by 1 wire P+ (J1.1) with 5V (J1.4)
Connection by 1 wire P- (J1.2) with 0V (J1.3)

ADAPTING THE RS 422 - RS 485 LINE

The line must always be adapted to the level of the reception channel of each subscriber forming the end of the bus. The ILPH is used to adapt the reception channel by setting the jumper Rt correctly :

Rt		* Line adaptation, Rt = 120 Ω (general case)
Rt		* Line adaptation, Rt = 220 Ω
Rt		* No line adaptation, Rt = ∞

RS 422 - RS 485 SERIAL LINK (2 wires)

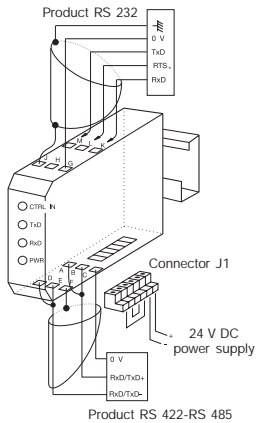

***CAUTION :**
When the RTS Signal is not activated, M terminal (RxD ILPH) has to be connected to L terminal (CTRL IN).

RS 422 - RS 485 SERIAL LINK (4 wires)

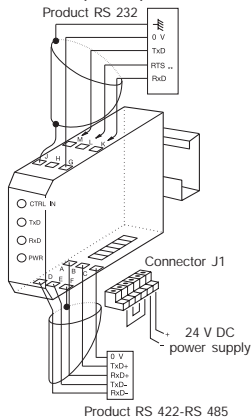

**** CAUTION :**
To be connected to 2 wired RS 485 only (not possible for 4 wired RS 422).
When the RTS Signal is not activated, M terminal (RxD ILPH) has to be connected to L terminal (CTRL IN).

Technical data

Power supply	polarized
Voltage	24 V DC
Voltage tolerance	8,5...28 V DC
Supply current	100 mA max
Connections	removable screw connectors (AWG 20)
RS 232-1 serial link	EIA RS 232 C / CCITT V24 V28
Overvoltage protection	integrated (transil 8 kV 1,2/50 μs)
Baud rate / Transmission distance	max. 38,4 kbits/s / max. 1200 m
Connections	2,5 mm ² screw connectors (AWG 20)
RS 422-485-2 serial link	EIA RS 485 and EIA RS 422 / CCITT V11
Overvoltage protection	integrated (transil 8 kV 1,2/50 μs)
Baud rate / Transmission distance	max. 38,4 kbits / max. 1200 m
Connections	2,5 mm ² screw connectors (AWG 20)
Traffic indication	
Voltage	1 yellow LED
Status of signal	2 green LED (RxD, TxD)
EMC behavior	
Electrostatic discharge	EN 61000-4-2 level 3 6/8 kV
Radiated electromagnetic field	EN 61000-4-3 level 310 V/m
Burst	EN 61000-4-4 level 3 1 kV
Electromagnetic compatibility	EN 55022 class B
Other characteristics	
Galvanic isolation between input / power supply / output	no
Configuration of the operating mode	using internal jumper
Operating temperature	0°C ... +50°C
Storage temperature	-25°C ... +80°C
Mounting	any required
DIN rail fixing (EN 50002)	snap-on mounting
Wire size	2,5 mm ² / stranded with ferrule, 4 mm ² solid
Dimensions (LxBxH)	88 x 22,5 x 102 mm
Weight	100 g

Serial data converters

"ILPH Range"

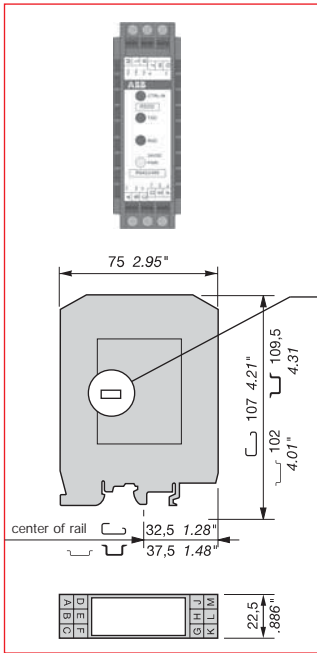

ILPH RS 232 / RS 422 - 485

- Galvanic isolated converter for RS 232 to RS 422-485 serial links.
- Galvanic isolation between input/output and output/power supply
- Baudrate up to 38,4 kbit/s
- Transmission distance up to 1200 m
- RS 485 1 or 2 pair handling
- Usable in "noisy" environments
- 24 V DC power supply
- CE mark

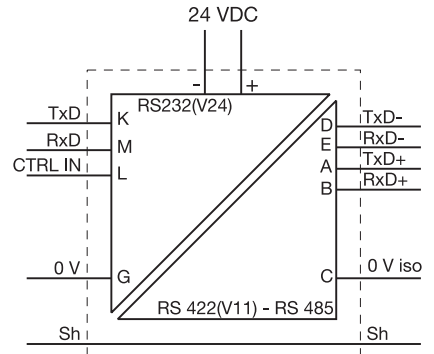

Description	Type	Order P/N	Packaging	Weight kg
Serial link interface with galvanic isolation	ILPH RS 232 / RS 422-485	1SNA 684 233 R2700	1	0,1

RS 485 LINK ON ONE PAIR

- R R ON/OFF Jumper R in position R ON/OFF
- E E ON/OFF Jumper E in position E ON/OFF

RS 422 LINK ON TWO PAIRS

- R R ON Jumper R in position R ON
- E E ON Jumper E in position E ON

The Receiver and the Transmitter are activated alternately (never at the same time) depending on the status of the CTRL IN signal.

The Transmitter and Receiver are both permanently active.

CTRL IN STATUS	ACTION ON RS 485
0 logic (+3V ≤ U ≤ +25V)	Transmitter active / Receiver inactive
1 logic (-25V ≤ U ≤ -3V)	Transmitter inactive / Receiver active
High impedance	Transmitter inactive / Receiver active

POLARIZATION OF THE RS 422 - RS 485 LINE

The line must always be polarized. The ILPH is used to polarize the reception channel :
 Connection by 1 wire P+ (J1.1) with 5V (J1.4)
 Connection by 1 wire P- (J1.2) with 0V (J1.3)

ADAPTING THE RS 422 - RS 485 LINE

The line must always be adapted to the level of the reception channel of each subscriber forming the end of the bus. The ILPH is used to adapt the reception channel by setting the jumper Rt correctly :

- Rt * Line adaptation, Rt = 120 Ω (general case)
- Rt * Line adaptation, Rt = 220 Ω
- Rt * No line adaptation, Rt = ∞

CAUTION : For RS 232 products running the RTS (REQUEST TO SEND) signal, connect RTS to CTRL IN. Otherwise, connect M (RxD ILPH) to L (CTRL IN).

RS 485 LINK ON 2 PAIRS

- R R ON Jumper R in position R ON
- E E ON/OFF Jumper E in position E ON/OFF

Receiver permanently active
 Transmitter controlled by the signal CTRL IN (see table for Transmitter operation as a function of CTRL IN)

Technical data

Power supply	polarized
Voltage	24 V DC
Voltage tolerance	8,5...28 V DC
Supply current	100 mA max
Connections	Removable screw connectors (Omniconnect)
RS 232-1 serial link	EIA RS 232 C / CCITT V24 V28
Overvoltage protection	integrated (transil 8 kV 1,2/50µs)
Baud rate / Transmission distance	max. 38,4 kbits/s / max. 15 m
Connections	2,5 mm² screw connectors (AWG 20)
RS 422-RS485-2 serial link	EIA RS 485 and EIA RS 422 / CCITT V11
Overvoltage protection	integrated (transil 8 kV 1,2/50 µs)
Baud rate / Transmission distance	max. 38,4 kbits / max. 1200 m
Connections	2,5 mm² screw connectors (AWG 20)
Traffic indication	
Voltage	1 yellow LED
Status of signal	3 green LED (RxD, TxD and CTRL-IN)
EMC behavior	
Electrostatic discharge	EN 61000-4-2 level 3 6/8 kV
Radiated electromagnetic field	EN 61000-4-3 level 310 V/m
Burst	EN 61000-4-4 level 3 1 kV
Electromagnetic compatibility	EN 55022 class B
Other characteristics	
Galvanic isolation between RS 232/RS 422-485 and RS 422-485/power supply	500 V DC
Configuration of the operating mode	using internal jumper
Operating temperature	0°C ... +50°C
Storage temperature	-25°C ... +80°C
Mounting	any required
DIN rail fixing (EN 50002)	snap-on mounting
Wire size	2,5 mm² / stranded with ferrule, 4 mm² solid
Dimensions (LxBxH)	88 x 22,5 x 102 mm
Weight	100 g

RS 422 - RS 485 2 WIRE SERIAL LINKS

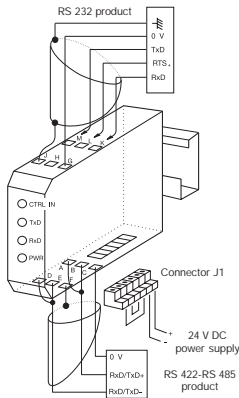

* CAUTION :
 If the RTS signal is not generated, connect M (RxD ILPH) to L (CTRL IN).

RS 422 - RS 485 4 WIRE SERIAL LINKS

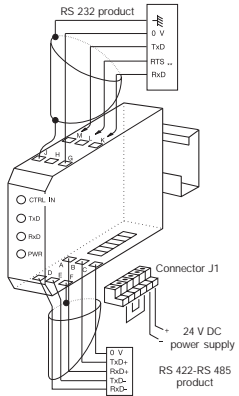

** CAUTION :
 Only to be connected for RS 485 two pairs (of no use for RS 422 two pairs). If the RTS signal is not generated, connect M (RxD ILPH) to L (CTRL IN).

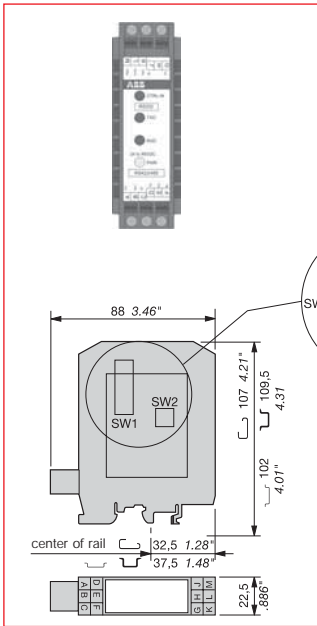

ILPH RS 232 / RS 422 - 485

- 3 way galvanic isolated converter for RS 232 to RS 422-485 serial links.
- 3 way galvanic isolation between power supply and input/output
- RS 485 switch on 2 or 4 wires
- Baudrate up to 38,4 kbit/s
- Transmission distance up to 1200 m
- RS 485 1 or 2 pair handling
- Usable in "noisy" environments
- 24...48 V DC and 115...230 V AC power supply
- CE marking

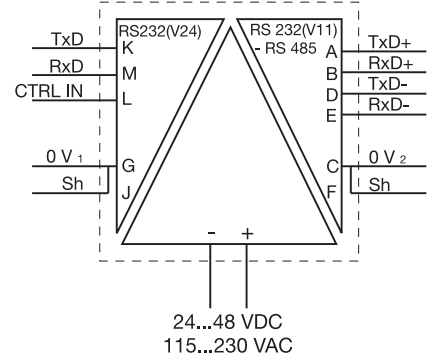

Description	Type	Order P/N	Packaging	Weight kg
Serial link interface	ILPH RS 232 / RS 422-485			
3 way galvanic isolation	24...48 V DC power supply	1SNA 684 333 R2300	1	0,1
	115...230 V AC power supply	1SNA 684 334 R2400	1	0,1

RS 422 - RS 485 2 WIRE SERIAL LINK

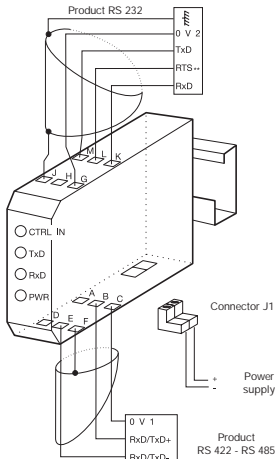

***CAUTION :**
When the RTS signal is not generated, set SW2-1 in position ON.

RS 422 - RS 485 4 WIRE SERIAL LINKS

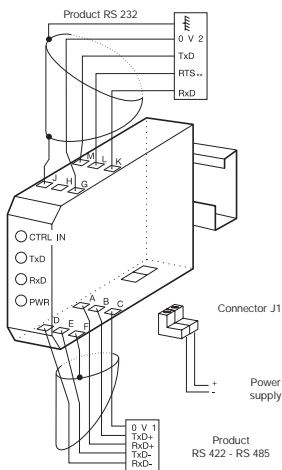

****CAUTION :**
Only to be connected for RS 485 two pairs (of no use for RS 422 two pairs). If the RTS signal is not generated, set SW2-1 in position ON.

RS 485 LINK ON ONE PAIR

Set SW1-1, SW1-3, SW1-6, SW1-7 and SW1-8 to position ON. The receiver and the transmitter are activated alternately (never at the same time), depending on the status of the CTRL IN signal.

CTRL IN STATUS	Action on RS 485
0 Logic (3V ≤ U ≤ +25V)	Transmitter active / Receiver inactive
1 Logic (-25V ≤ U ≤ -3V)	Transmitter inactive / Receiver active
High impedance	Transmitter inactive / Receiver active

CAUTION : For RS 232 products running the RTS signal (REQUEST TO SEND), connect RTS to CTRL IN. Otherwise, set SW2-1 to position ON.

RS 485 LINK ON TWO PAIRS

Set SW1-1, SW1-3, SW1-7 in position OFF.
Set SW1-6, SW1-8 in position ON.
The receiver is permanently active.
The transmitter is controlled by the signal CTRL IN (see table for transmitter operation as a function of CTRL IN).

RS 422 LINK ON TWO PAIRS

Set SW1-1, SW1-3, SW1-7 and SW1-8 in position OFF.
Set SW1-6 in position ON.
Transmitter and receiver are both permanently active.

POLARIZATION OF THE RS 422 - RS 485 LINE

The line must always be polarized.
The ILPH is used to polarize the reception channel :
Set SW1-4 and SW1-5 in position ON.

ADAPTING THE RS 422 - RS 485 LINE

The line must always be adapted to the level of the reception channel of each subscriber forming the end of the bus.

The ILPH is used to adapt the reception channel by setting the jumper SW1-2 correctly :

- SW1-2 in position ON ⇒ line adaptation, $R_t = 120 \Omega$ (standard)
- SW1-2 in position OFF ⇒ no line adaptation, $R_t = \infty$

Technical data

Power supply	Polarization for DC model	
Voltage	24...48 V DC	115...230 V AC (50/60 Hz)
Voltage tolerance	-15% ... +20%	-15% ... +15%
Supply current	24 V DC < 110 mA, 48 V DC < 55 mA, 115 V AC < 40 mA, 230 V DC < 26 mA	
Supply power	≈ 3 W	≈ 3 VA
Connections	Removable screw connector (Omniconnect)	
RS 232-1 serial link	EA / TIA RS 232 new revision / CCITT V24 V28	
Overvoltage protection	integrated (transil 8 kV 1,2/50 μs)	
Baud rate / Transmission distance	max. 38,4 kbits/s / max. 15 m / 2500 pF	
Connections	2,5 mm ² screw (AWG 20)	
RS 422/485-2 serial link	EIA RS 485 and EIA RS 422 CCITT V11	
Overvoltage protection	integrated (transil 8 kV 1,2/50 μs)	
Baud rate / Transmission distance	max. 38,4 kbits / max. 1200 m	
Connections	2,5 mm ² screw (AWG 20)	
Traffic indication		
Voltage	1 yellow LED	
Status of signal	3 green LED (Rx/D, Tx/D and CTRL-IN)	
EMC behavior		
Electrostatic discharge	EN 61000-4-2 level 3 6/8 kV	
Radiated electromagnetic field	EN 61000-4-3 level 310 V/m	
Burst	EN 61000-4-4 level 3 1 kV	
Electromagnetic compatibility	EN 55022 class B	
Other characteristics		
Galvanic isolation between		
RS 232 / Power supply / RS 422-RS 485	1,5 kV	
Configuration of the operating mode	using internal jumper	
Operating temperature	0°C ... +50°C	
Storage temperature	-25°C ... +80°C	
Mounting	any required	
DIN rail fixing (EN 50002)	snap-on mounting	
Wire size	2,5 mm ² / stranded with ferrule, 4 mm ² solid	
Dimensions (LxBxH)	88 x 22,5 x 102 mm	
Weight	100 g	

Serial data converters

"ILPH Range"

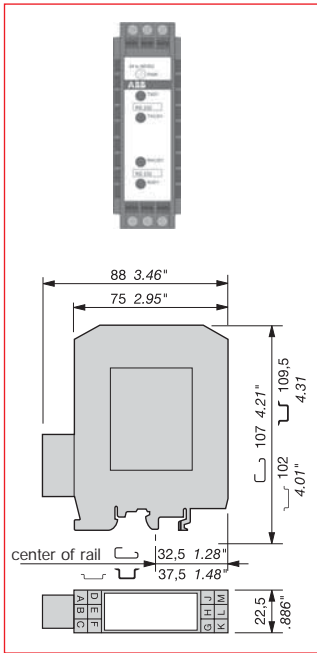

ILPH RS 232 / RS 232

3 way galvanic isolator between RS 232 serial interface and another RS 232 serial interface.

- Ensures triple insulation between the 2 serial interfaces and between each and power supply
- Baudrate up to 19,2 kbit/s (up to 64 kbit/s depending on cable)
- Transmission distance up to 15 m
- Can be used in "noisy" environments
- Power supply from 24...48 V DC and 115...230 V AC
- CE marking

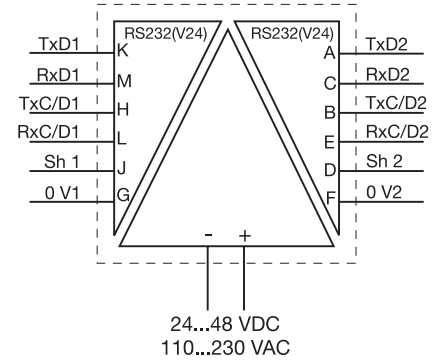

Description	Type	Order P/N	Packaging	Weight kg
Serial link interface	ILPH RS 232 / RS 232			
3 way galvanic isolation	24...48 V DC power supply	1SNA 684 234 R2000	1	0,1
	115...230 V DC power supply	1SNA 684 244 R0200	1	0,1

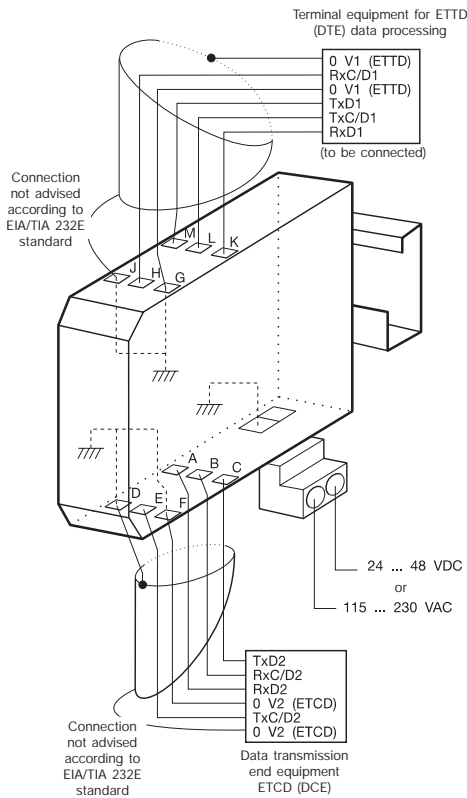

Technical data

Power supply	DC model polarized
Voltage	24...48 V DC
Voltage tolerance	-15%...+20%
Supply current	24 V DC<155 mA;48 V DC<77 mA;110 V AC<40 mA;230 V DC<26 mA
Supply power	≈ 3,15 W
Connections	Removable screw connector (Omniconnect)
RS 232-1 interface	EIA / TIA RS 232 new revision / CCITT V24 V28
Overvoltage protection	integrated (transil 8 kV 1,2/50 μs)
Transmission capacity / Transmission distance	max. 19,2 kbits/s / max. 15 m / 2500 pF
Connections	2,5 mm² screw (AWG 20)
RS 232-2 interface	EIA / TIA RS 232 new revision / CCITT V24 V28
Overvoltage protection	integrated (transil 8 kV 1,2/50μs)
Transmission capacity / Transmission distance	max. 19,2 kbits/s / max. 15 m
Connections	2,5 mm² screw (AWG 20)
Traffic indication	
Voltage	1 yellow LED
Status of signal	4 green LED (Rx/D, Rx/C/D, Tx/D, Tx/C/D)
EMC behavior	
Electrostatic discharge	EN 61000-4-2 level 3 6/8 kV
Radiated electromagnetic field	EN 61000-4-3 level 3 10 V/m
Burst	EN 61000-4-4 level 3 1 kV
Electromagnetic compatibility	EN 55022 class B
Other characteristics	
Galvanic isolation between input / power supply / output	1,5 kV
Configuration of the operating mode	No
Operating temperature	0°C ... +50°C
Storage temperature	-25°C ... +80°C
Mounting	any required
DIN rail fixing (EN 50002)	snap-on mounting
Wire size	2,5 mm² / stranded with ferrule, 4 mm² solid
Dimensions (LxBxH)	88 x 22,5 x 102 mm
Weight	100 g

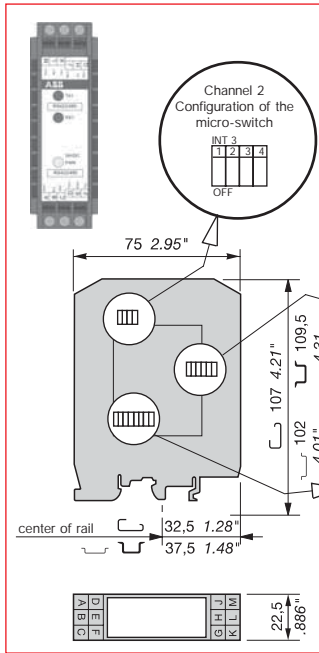

ILPH RS 422 - 485 / RS 422 - 485

Galvanic isolated connection between an RS 422-485 (1 or 2 pairs) and an RS 422 485 (1 or 2 pairs) serial link. It amplifies the signal beyond the 1200 m limit distance of the RS 422-485 and only needs a minimum of 1,5 character delay time to switch off the RS 485 drivers.

- Galvanic isolation between power supply/output and input/output
- Baudrate up to 500 kbit/s (up to 200 m)
- Transmission distance up to 1200m at 38,4 kbit/s
- Usable in "noisy" environments
- 2/4 wires automatic handling
- 24 V DC power supply
- CE mark

	INT 1	INT 2	INT 3	INT 4
BAUD RATE	1 2 3 4	1 2 3 4	1 2 3 4	1 2 3 4 5 6
FULL DUPLEX	0 0 0 0	0 0 0 0	X X X 1	X X X 1 0 1
500 Kb/s	1 1 1 1	1 1 1 1	X X X 0	X X X 0 0 0
187,5 Kb/s	1 1 1 1	1 1 1 0	X X X 0	X X X 0 0 0
93,75 Kb/s	1 1 1 1	1 1 0 0	X X X 0	X X X 0 0 0
38,4 Kb/s	1 1 1 1	1 0 0 0	X X X 0	X X X 0 0 0
19,2 Kb/s	1 1 1 1	0 0 0 0	X X X 0	X X X 0 0 0
9,6 Kb/s	1 1 1 0	0 0 0 0	X X X 0	X X X 0 0 0
4,8 Kb/s	1 1 0 0	0 0 0 0	X X X 0	X X X 0 0 0
2,4 Kb/s	1 0 0 0	0 0 0 0	X X X 0	X X X 0 0 0
1,2 Kb/s	0 0 0 0	0 0 0 0	X X X 0	X X X 0 0 0

N_U = not used 1 = contact closed
 X = zero 0 = contact open (aus) (off)

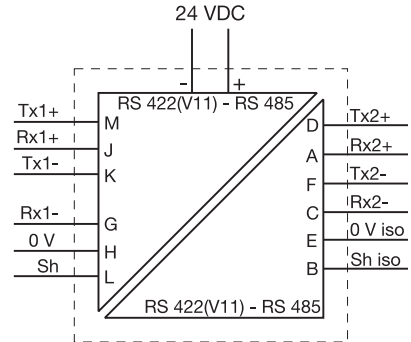

Description	Type	Order P/N	Packaging	Weight kg
Serial link interface with galvanic isolation	ILPH RS 422 - 485 / RS 422 - 485	1SNA 684 212 R2200	1	0,1

RS 422 - RS 485 2 wire serial link

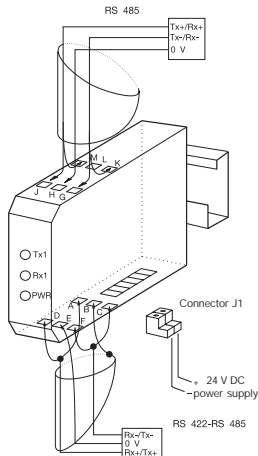

RS 422 - RS 485 DRIVERS CONTROL

The RS 422 - RS 485 Drivers Control (transmitters and receivers) makes the ILPH easy to use. The control of the 2 channels is completely automatic ; you only have to configure the baud rate needed.

The minimum turn off delay is about 1,5 character/time from 27 µs to 10 ms depending on the baud rate selected.

POLARIZATION OF THE RS 422 - RS 485 CONNECTIONS

The connections must always be polarized. The ILPH is used to polarize the reception channels :

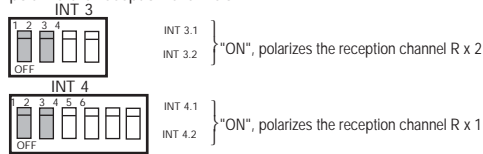

ADAPTING THE RS 422 - RS 485 CONNECTIONS

The connections must always be adjusted to the level of the reception channel of each subscriber forming the end of the bus. The ILPH is used to adjust the reception channel by setting the micro-switch INT 3.3 and INT 4.3.

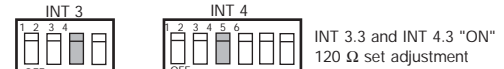

BAUD RATE

By using the 8 micro-switches inside the box.

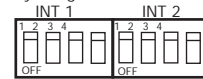

Permits to define up to 8 transmission speeds and to select the Full Duplex operation mode (RS 422 / RS 422) in addition with the INT 3.4 INT 4.4 and INT 4.5 micro switches.

Technical data

Power supply	DC model polarized
Voltage	24 V DC
Voltage tolerance	+/-15%
Supply current	120 mA max.
Connections	Removable screw connector (Omniconnect)
RS 422-485-1 interface	EIA / RS 432 and EIA RS 422 / CCITT V11
Overvoltage protection	integrated (transil 8 kV 1,2/50 µs)
RS 485 data switching	Time switching / Time delay transmission/reception 27 µs ...10 ms
Baudrate / Transmission distance	from 1,2 to 500 kbits/s / max. 1200 m up to 38,4 kbit/s
Connections	2,5 mm ² screw (AWG 20)
RS 422-485-2 interface	EIA / RS 485 and EIA RS 422 / CCITT V11
Overvoltage protection	integrated (transil 8 kV 1,2/50 µs)
RS 485 data switching	Time switching / Time delay transmission/reception 27 µs ...10 ms
Baudrate / Transmission distance	from 1,2 to 500 kbits/s / max. 1200 m up to 38,4 kbit/s
Connections	2,5 mm ² screw (AWG 20)
Traffic indication	
Voltage	1 yellow LED
Status of signal	2 green LED (RxD, Tx,D,)
EMC behavior	
Electrostatic discharge	EN 61000-4-2 level 3 6/8 kV
Radiated electromagnetic field	EN 61000-4-3 level 3 10 V/m
Burst	EN 61000-4-4 level 3 1 kV
Electromagnetic compatibility	EN 55022 class B
Other characteristics	
Galvanic isolation between input / power supply / output	500 V DC
Configuration of the operating mode	using internal DIP switches
Operating temperature	0°C ... +50°C
Storage temperature	-25°C ... +80°C
Mounting	any required
DIN rail fixing (EN 50002)	snap-on mounting
Wire size	2,5 mm ² / stranded with ferrule, 4 mm ² solid
Dimensions (LxBxH)	88 x 22,5 x 102 mm
Weight	100 g

RS 422 - RS 485 4 wire serial link

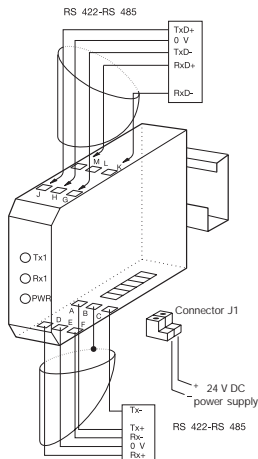

Caution :
 The transmission channels of both RS 422 - RS 485 serial link interfaces always have to be independently polarized.

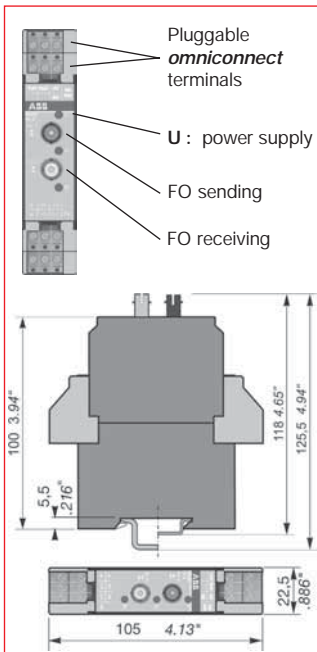

ILPH RS 232 / FO

3 way galvanic isolated Converter for RS 232 to optical fiber serial link glass (S) or plastic (P).

- 3 way galvanic isolation between power supply and input/output
- Baud rate up to 115,2 kbit/s
- Available for glass or plastic fiber
- Transmission distance up to 4 km
- Usable in "very noisy" environments
- 20...42 V AC/DC and 110...240 V AC/DC power supply
- CE marked

■ Approvals : in process

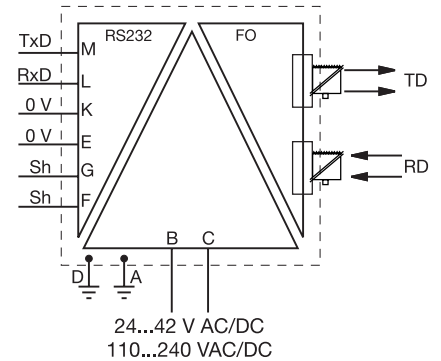

Description	Type	Order P/N	Packaging	Weight kg
Serial link interface	ILPH RS 232 / FO-S			
3 way galvanic isolation	24...42 V AC/DC Power supply	1SNA 684 236 R2200	1	0,15
	110...240 V AC/DC Power supply	1SNA 684 237 R2300	1	0,15
Serial link interface	ILPH RS 232 / FO-P			
3 way galvanic isolation	24...42 V AC/DC Power supply	1SNA 684 238 R0400	1	0,15
	110...240 V AC/DC Power supply	1SNA 684 239 R0500	1	0,15

RS 232 / FO

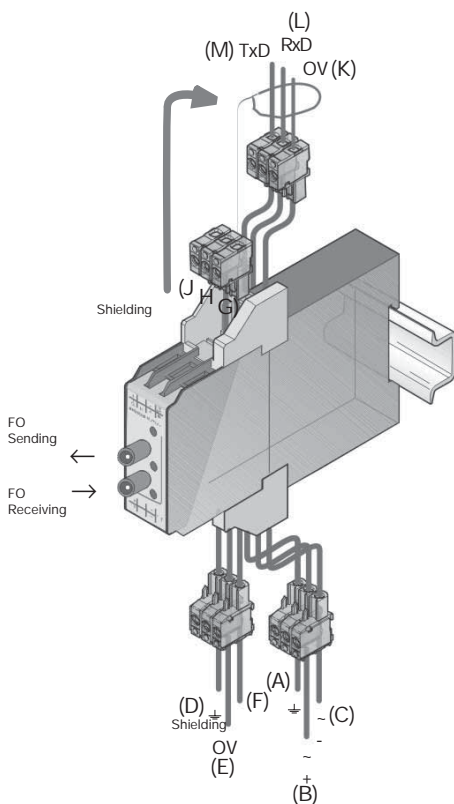

Technical data

Power supplies			
Supply voltage	24...42 V AC/DC (50/60 Hz)	110...240 V AC/DC (50/60 Hz)	
Voltage tolerance	-15% ... +10%	-15% ... +10%	
Connections	Omniconnect pluggable connector		
RS 232 Interface 1	CCITT V.24/DIN 66020- CCITT V.28 DIN 66259-EIA 232 E		
Protection	Integrated (transil 8 kV 1.2/50µs)		
Max. speed / Max. distance	Max. 115.2 kbits/s / max. 15 m / 2500 pF		
Connections	Omniconnect pluggable connector		
Fiber optic interface 2	DIN VDE 0888-1		
Type of fiber / Connections	Multimode fiber Glass : ST connector Plastic : FSMA screw connector		
Wavelength	Glass : 820 nm Plastic : 655 nm		
Max. transmission power	Glass : 50/125 µm : -14.4 db/m Glass : 62.5/125 µm : -14 db/m Plastic : 980/1000 µm : -8 db/m		
Max. reception power	Glass : -28 db/m Plastic : -20 db/m		
Max. speed	Max. 115.2 kbits/s		
Max. distance	Glass : 50/125 µm : 3 km Glass : 62.5/125 µm : 4 km Plastic : 980/1000 µm : 40 m		
Status indication			
Power supply / Data exchange	1 green LED / 2 green LEDs (RxD, TxD)		
EMC behavior			
Electrostatic discharge	EN 61000-4-2 Level 3 6/8 kV		
Radiated electromagnetic field	EN 61000-4-3 Level 3 10 V/m		
Burst	EN 61000-4-4 Level 3 1 kV		
Electromagnetic compatibility	EN 55022 Class B		
Other characteristics			
Galvanic isolation input / power supply / output	2.5 kV		
Operating temperature	-20°C ... +60°C		
Storage temperature	-40°C ... +85°C		
Mounting	Onto DIN Rail (EN 50002)		
Connections	14 AWG (2.5 mm ²) fine stranded / 12 AWG (4 mm ²) rigid		
Dimensions (LxWxH)	105 x 22.5 x 112 mm / 4.13 x 0.89 x 4.41"		
Weight	150 g / 0.33 lb		

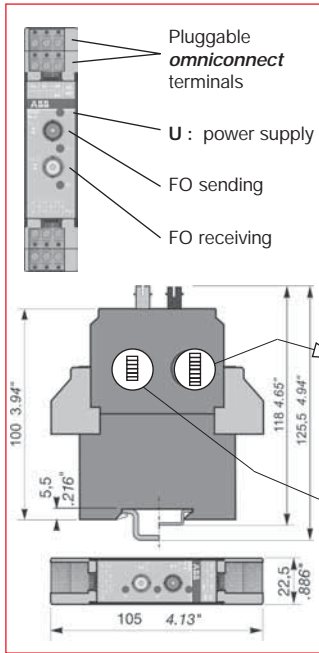

ILPH RS 485 / FO

- 3 way galvanic isolated converter for RS 485 (1 pair) to optical fiber serial link glass (S) or plastic (P).
- 3 way galvanic isolation between power supply and input/output
- Baud rate up to 1.5 Mbit/s
- Available for glass fiber or plastic fiber
- Transmission distance up to 4 km
- Usable in "very noisy" environments
- 20...42 V AC/DC and 110...240 V AC/DC power supply
- CE marked

Approvals : in process

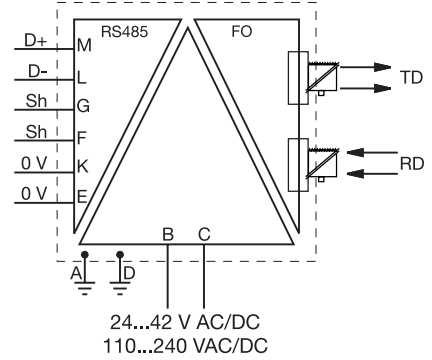

Baud rate :
SW1 DIP switch configuration

Baudrate bit/s	SW 1							
	1	2	3	4	5	6	7	8
1500000								
500000								
375000								
187500								
136000								
115200								
93750								
75000								
57600								
38400								
19200								
9600								
4800								
300								

Legend

<input checked="" type="checkbox"/>	on
<input type="checkbox"/>	off

End-of-line resistor, polarization
SW2 DIP switch configuration

	SW 2					
	1	2	3	4	5	6
Polarization						
EOL 60 ohm						
EOL 120 ohm						
EOL 180 ohm						
EOL 240 ohm						
EOL indefinite						

Description	Type	Order P/N	Packaging	Weight kg
Serial link interface 3 way galvanic isolation	ILPH RS 485 / FO-S			
	24...42V AC/DC Power supply	1SNA 684 246 R0400	1	0,15
	110...240 V AC/DC Power supply	1SNA 684 247 R0500	1	0,15
Serial link interface 3 way galvanic isolation	ILPH RS 485 / FO-P			
	24...42V AC/DC Power supply	1SNA 684 248 R1600	1	0,15
	110...240 V AC/DC Power supply	1SNA 684 249 R1700	1	0,15

RS 485 / FO

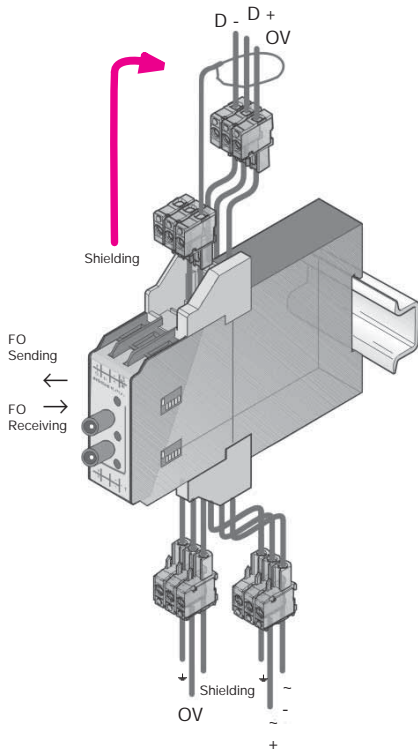

Technical data

Power supplies	
Supply voltage	24...42 V AC/DC (50/60 Hz) 110...240 V AC/DC (50/60 Hz)
Voltage tolerance	-15% ... +10% -15% ... +10%
Connections	Omniconnect pluggable connector
RS 485 interface 1	ISO / IEC 8482 / DIN 66 259-4; EIA 485
Protection	Integrated (8 kV 1.2/50µs)
Max. speed / max. distance	Max. 1.5 Mbits/s / max. 1200 m (38.4 kbit/s)
Connections	Omniconnect Pluggable connector
Optic fiber interface 2	DIN VDE 0888-1
Type of fiber / Connections	Multimode fiber Glass : ST connector Plastic : FSMA screw connector
Wavelength	Glass : 820 nm Plastic : 655 nm
Max. transmission power	Glass : 50/125 µm : -14.4 db/m Glass : 62.5/125 µm : -14 db/m Plastic 980/1000 µm : -8 db/m
Max. reception power	Glass : -28 db/m Plastic : -20 db/m
Max. speed	Max. 1.5 Mbit/s
Max. distance	Glass : 50/125 µm : 3 km Glass : 62.5/125 µm : 4 km Plastic 980/1000 µm : 40 m
Status indication	
Power supply / Data exchange	1 green LED / 2 green LEDs (Rx/D, Tx/D)
EMC behavior	
Electrostatic discharge	EN 61000-4-2 Level 3 6/8 kV
Radiated electromagnetic field	EN 61000-4-3 Level 3 10 V/m
Burst	EN 61000-4-4 Level 3 1 kV
Electromagnetic compatibility	EN 55022 Class B
Other characteristics	
Galvanic isolation input / power supply / output	2.5 kV
Function configuration	With DIP-Switches
Operating temperature	-20°C ... +60°C
Storage temperature	-40°C ... +85°C
Mounting	Onto DIN Rail
Connections	14 AWG (2,5mm ²) / fine stranded, 12 AWG (4 mm ²) rigid
Dimensions (LxWxH)	105 x 22.5 x 112 mm / 4.13 x 0.89 x 4.41"
Weight	150 g / 0.33lb

Serial data converters

"ILPH Range"

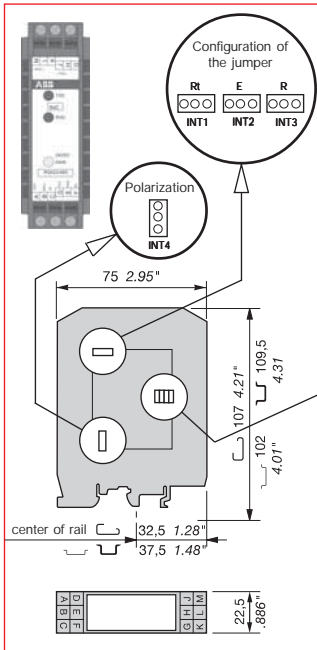

ILPH CL / RS 422 - 485

Galvanic isolated converter for current loop to RS 422-485 (1 or 2 pairs) serial link.

- Galvanic isolation between power supply/current loop and RS 422-485/current loop
- Active/passive 0...20 mA / 4...20 mA selectable
- Positive or negative logic selectable
- Baudrate up to 38,4 kbit/s (up to 2400 m)
- Transmission distance up to 2400 m (1200 m RS 485 and 1200 m current loop)
- Usable in "noisy" environments
- 24 V DC power supply
- CE marking

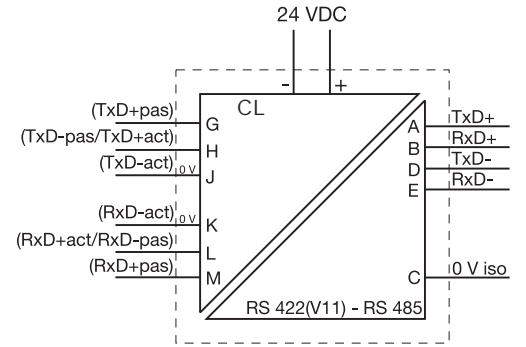

RS 422 - RS 485 2 wire serial link

CONNECTIONS

Example of connection with a CL (current Loop) product, Transmission (TxD) in active mode and Reception (Rx) in passive mode. Then, the ILPH must be configured and connected Reception (Rx) in passive mode and Transmission (Tx) in active mode.
Note : For any other configuration, see schematic diagram or front sticker of the product.

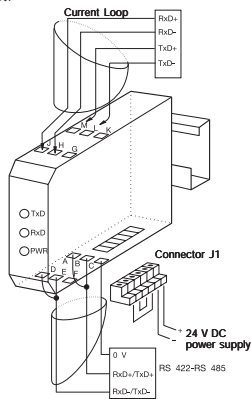

RS 422 - RS 485 4 wire serial link

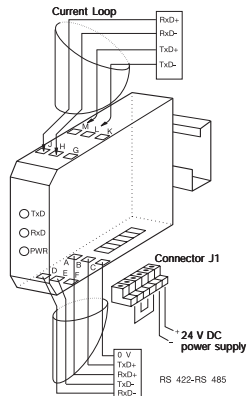

Note : The Tx channel of the RS 422 - RS 485 link must be polarized independently too.

Description	Type	Order P/N	Packaging	Weight kg
Serial link interface with galvanic isolation	ILPH BdC / RS 422 - 485 24 V DC power supply	1SNA 684 232 R2600	1	0,1

LINE AMPLIFIER CONFIGURATION

Configuration of amplifiers of the RS 422 - RS 485 (Receiver, Transmitter) line provides greater flexibility of use. The various configurations can be selected using the 2 jumpers (R INT2, E INT1) located inside the box.

RS 485 LINK ON ONE PAIR

- R INT2 R ON/OFF Jumper R in position R ON/OFF
- E INT3 E ON/OFF Jumper E in position E ON/OFF

The Receiver and the Transmitter are activated alternately (never at the same time) depending on the status of the Current Loop Reception signal.

RS 485 LINK ON TWO PAIRS

- R INT2 R ON R ON Jumper R in position R ON
- E INT3 E ON/OFF E ON/OFF Jumper E in position E ON/OFF

Receiver permanently active. Transmitter controlled by the Current Loop Reception signal.

RS 422 LINK ON TWO PAIRS

- R INT2 R ON R ON Jumper R in position R ON
- E INT3 E ON E ON Jumper E in position E ON

The Receiver and the Transmitter are both permanently active.

POLARIZATION OF THE RS 422 - RS 485 LINE

The line must always be polarized. The ILPH is used to polarize the reception channel :
Connection by 1 wire P+ (J1.1) with 5 Viso (J1.4)
Connection by 1 wire P- (J1.2) with 0 Viso (J1.3)

ADAPTING THE RS 422 - RS 485 LINE

The line must always be adapted to the level of the reception channel of each subscriber forming the end of the bus. The ILPH is used to adapt the reception channel by setting the jumper Rt correctly :

- Rt INT1 * Line adaptation, Rt = 120 Ω (Standard)
- Rt INT1 * No line adaptation, Rt = ∞

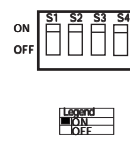

Transmission (Tx) active
Transmission(TxD) passive
Reception (Rx) active
Reception (Rx) passive
4...20 mA Signal
0...20 mA Signal
Signal logic 1 = 20 mA
Signal logic 0 = 20 mA

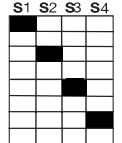

POLARIZATION

The polarization can be configured using the INT4 jumper.

- INT4 Protection ON
- INT4 Protection OFF, used if power supply at minimum value (21,6 V).

Technical data

Power supply	DC model polarized
Voltage	24 V DC
Voltage tolerance	+/-10%
Supply current	120 mA max.
Connections	Removable screw connector (Omniconnect)
CL interface (Current Loop 1)	active/passive 0...20 mA / 4...20 mA, mode is settable
Logic level	0 = 20 mA or 1 = 20 mA, settable
Baud rate / Transmission distance	max. 38,4 kbit/s / max. 1200 m
Connections	2,5 mm ² screw (AWG 20)
RS 422/485-2 serial link	EIA RS 485 and EIA RS 422 / CCITT V 11
Overvoltage protection	integrated (transil 8 kV 1,2/50 μs)
Baud rate / Transmission distance	max. 38,4 kbit/s / max. 1200 m
Connections	2,5 mm ² screw (AWG 20)
Traffic indication	
Voltage	1 yellow LED
Status of signal	2 green LED (Rx, Tx)
EMC behavior	
Electrostatic discharge	EN 61000-4-2 level 3 6/8 kV
Radiated electromagnetic field	EN 61000-4-3 level 3 10 V/m
Burst	EN 61000-4-4 level 3 1 kV
Electromagnetic compatibility	EN 55022 class B
Other characteristics	
Galvanic isolation between input / output and power supply / output	depending on Current Loop (active/passive) 500 V DC (active) / 2000 V DC (passive)
RS 422-485 power supply	500 V DC
Configuration of the operating mode	using internal DIP switches
Operating temperature	0°C ... +50°C
Storage temperature	-25°C ... +80°C
Mounting	any required
DIN rail fixing (EN 50002)	snap-on mounting
Wire size	2,5 mm ² / stranded with ferrule, 4 mm ² solid
Dimensions (LxBxH)	88 x 22,5 x 102 mm
Weight	100 g

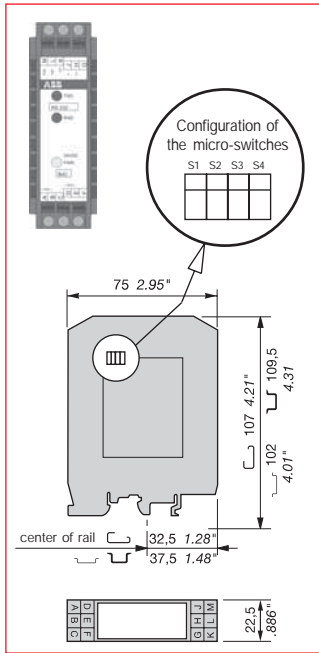

ILPH RS 232 / CL

Galvanic isolated Converter for RS 232 to current loop serial link.

- Galvanic isolation between power supply/current loop and RS 232/current loop
- Active/Passive 0...20 mA / 4...20 mA selectable
- Positive or negative logic selectable
- Baudrate up to 38,4 kbit/s
- Transmission distance up to 1200 m
- Usable in "noisy" environments
- 24 V DC power supply
- CE marking

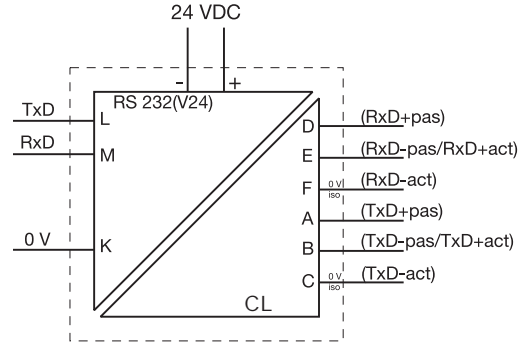

Description	Type	Order P/N	Packaging	Weight kg
Serial link interface with galvanic isolation	ILPH RS 232 / BdC 24 V DC power supply	1SNA 684 202 R0100	1	0,1

CONFIGURATION

The various configurations can be selected using the 4 micro-switches located inside the box.

OPERATING MODE ACTIVE OR PASSIVE

The Current Loop's Transmission and Reception can be independently in active or passive mode. Select operating mode using S1 and S2.



SIGNAL LEVEL

Select signal level 4-20 mA or 0-20 mA. This selection is made using micro-switch S3

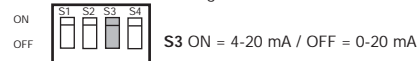

Caution : It is not possible to select a 4-20 mA signal when the Reception is in active mode.

LOGIC LEVEL

Configuration : Positive logic (0 Logic = 20 mA) or negative logic (1 Logic = 20 mA) using micro-switch S4

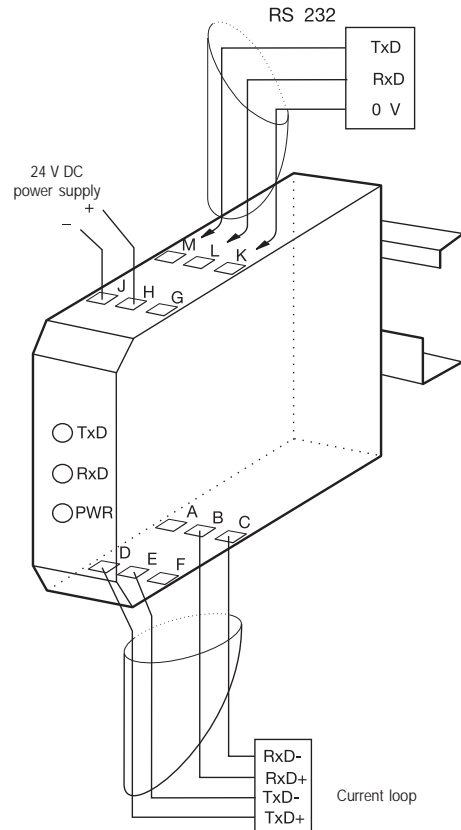
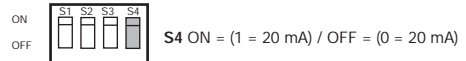

CONNECTIONS

Example of connection with a CL (Current Loop) product, Transmission (TxD) in active mode and Reception (RxD) in passive mode. Then, the ILPH must be configured and connected Reception (RxD) in passive mode and Transmission (TxD) in active mode.

CAUTION : For any other configuration, see schematic diagram or front sticker of the product.

Technical data

Power supply	DC model polarized
Voltage	24 V DC
Voltage tolerance	+/-10%
Supply current	120 mA max.
Connections	Removable screw connector (Omniconnect)
RS 232-1 serial link	EIA RS 232 C / CCITT V 24 V 28
Overvoltage protection	integrated (transil 8 kV 1,2/50 µs)
Baud rate / Transmission distance	max. 38,4 kbit/s / max. 15 m
Connections	2,5 mm² screw (AWG 20)
BdC serial link (current loop) 2	active/passive 0...20 mA / 4...20 mA mode settable
Logic level	0=20 mA or 1=20 mA settable
Baud rate / Transmission distance	max. 38,4 kbit/s / max. 1200 m
Connections	2,5 mm² screw (AWG 20)
Traffic indication	
Voltage	1 yellow LED
Status of signal	2 green LED (RxD, TxD)
EMC behavior	
Electrostatic discharge	EN 61000-4-2 level 3 6/8 kV
Radiated electromagnetic field	EN 61000-4-3 level 3 10 V/m
Burst	EN 61000-4-4 level 3 1 kV
Electromagnetic compatibility	EN 55022 class B
Other characteristics	
Galvanic isolation between Current loop / RS 232	depending on current loop (active/passive) 500 V DC (active) / 2000 V DC (passive)
Current loop / power supply	500 V DC (active) / 2000 V DC (passive)
Configuration of the operating mode	using internal DIP switches
Operating temperature	0°C ... +50°C
Storage temperature	-25°C ... +80°C
Mounting	any required
DIN rail fixing (EN 50002)	snap-on mounting
Wire size	2,5 mm² / stranded with ferrule, 4 mm² solid
Dimensions (LxBxH)	88 x 22,5 x 102 mm
Weight	100 g