

SLIDE SWITCHES (SMD)

RoHS compliant

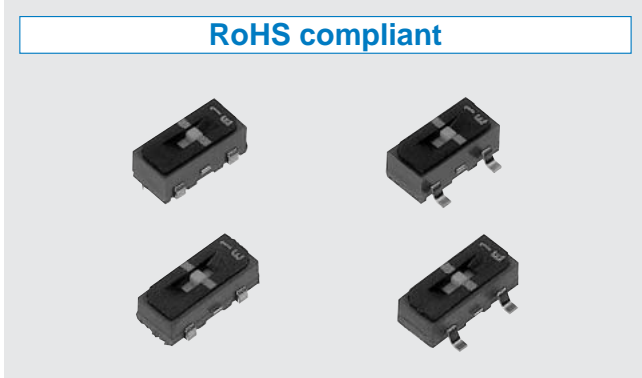

INTERNAL STRUCTURE

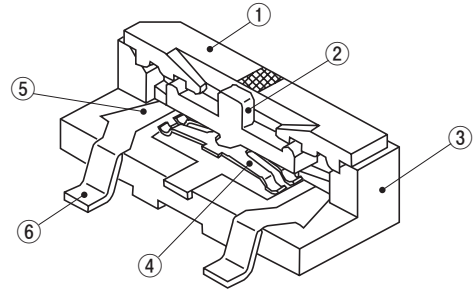

Part name	Material	Flammability
① Cover	PPS(Polyphenylenesulphide)	UL-94V-0
② Slider	PA(Polyamide)	
③ Housing	PPS(Polyphenylenesulphide)	
④ Slider contact	Copper alloy, Gold-plated	—
⑤ Fixed contact		
⑥ Terminal pin		

FEATURES

- RoHS compliant
- Easy to set slider with line marking
- With neutral detent type lined up to 1 pole 2contacts switch
- Compatible with most automatic pick & place machinery
- Compact and space saving SMD type

PART NUMBER DESIGNATION

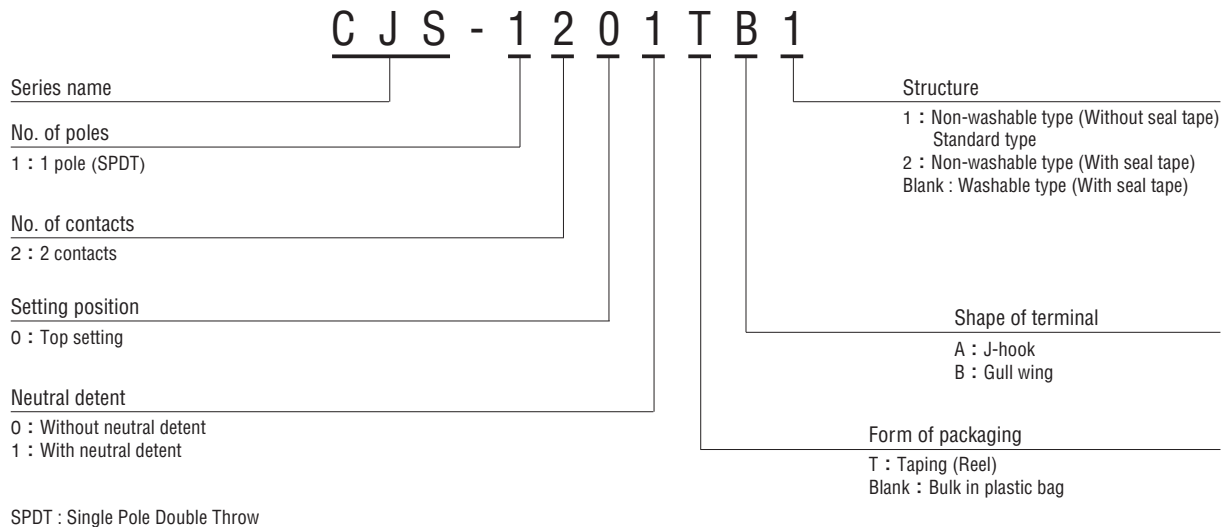

※Please refer to the LIST OF PART NUMBERS when placing orders.

LIST OF PART NUMBERS

No. of poles	No. of contacts	Setting position	Neutral detent	Form of packaging	Non-washable type (Without seal tape)		Non-washable type (With seal tape)		Pieces in package
					A (J-hook)	B (Gull wing)	A (J-hook)	B (Gull wing)	
1	2	Top setting	Without neutral detent	Taping	CJS-1200TA1	CJS-1200TB1	CJS-1200TA2	CJS-1200TB2	1000pcs./reel
				Plastic bag	CJS-1200A1	CJS-1200B1	CJS-1200A2	CJS-1200B2	100pcs./pack
			With neutral detent	Taping	CJS-1201TA1	CJS-1201TB1	CJS-1201TA2	CJS-1201TB2	1000pcs./reel
				Plastic bag	CJS-1201A1	CJS-1201B1	CJS-1201A2	CJS-1201B2	100pcs./pack

No. of poles	No. of contacts	Setting position	Neutral detent	Form of packaging	Washable type (With seal tape)		Pieces in package
					A (J-hook)	B (Gull wing)	
1	2	Top setting	Without neutral detent	Taping	CJS-1200TA	CJS-1200TB	1000pcs./reel
				Plastic bag	CJS-1200A	CJS-1200B	100pcs./pack
			With neutral detent	Taping	CJS-1201TA	CJS-1201TB	1000pcs./reel
				Plastic bag	CJS-1201A	CJS-1201B	100pcs./pack

※ Verify the above part numbers when placing orders.
Taping version can be supplied only in reel unit.

STANDARD SPECIFICATIONS

Operating temp. range	- 40 ~ 85 °C
Storage temp. range	
Sealing	Washable type available with seal tape
Net weight	Approx. 0.05g (CJS-1200) Approx. 0.06g (CJS-1201)

ELECTRICAL CHARACTERISTICS

Contact rating Non-switching Switching Minimum	DC50 V 100 mA DC6 V, 100 mA DC24 V, 25 mA DC20 mV 1 μA
Contact resistance	100 mΩ maximum
Insulation resistance	100 MΩ (DC100 V) minimum
Dielectric strength	AC250 V, 60 s

MECHANICAL CHARACTERISTICS

Operating force	5.9 N {0.6 kgf} maximum
Stop strength	10 N {1.02 kgf}, 60 s
Solderability	245 ± 3 °C, 2 ~ 3 s
Soldering heat	Reflow : 255 °C (Peak temperature) (Please refer to the profile below)
	Manual soldering : 350 ± 10 °C, 3 ~ 4 s
Shear (Adhesion)	5 N {0.51 kgf} 10 s
Substrate bending	Width 90 mm, bend 3 mm, 5 s, 1 time
Pull-off strength	5 N {0.51 kgf} 10 s

ENVIRONMENTAL CHARACTERISTICS

Vibration	Amplitude 1.5mm or Acceleration 98m/s ² , 10-500 Hz, 3 directions for 10 cycles each
Shock	490 m/s ² , 11 ms 6 directions for 3 times each
Load life	Continuous load 200 cycles, DC6 ± 0.5 V, 100 ± 10 mA
Humidity	-10 ~ 65 °C, Relative humidity 0 ~ 96 %, 24 h for 10 cycles
High temp. exposure	85 °C, 96 h
Low temp. exposure	-40 °C, 96 h
Thermal shock	-40 (0.5 h) ~ 85 °C (0.5 h), 5 cycles

{ } : Reference only

<Reflow profile for soldering heat evaluation>

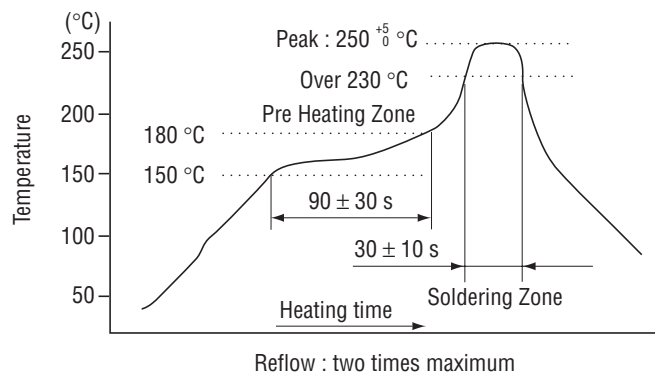

OUTLINE DIMENSIONS

Unless otherwise specified, tolerance : ± 0.3 (Unit : mm)

● CJS-1200A1

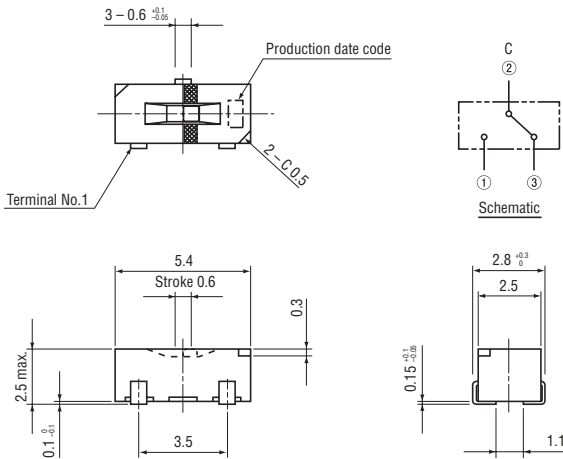

● CJS-1200B1

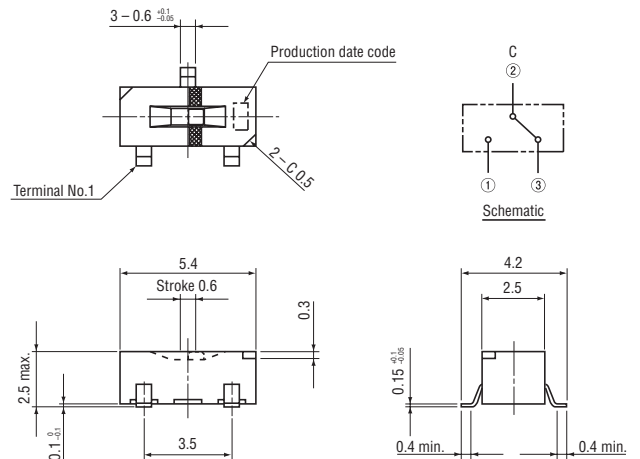

● CJS-1201A1

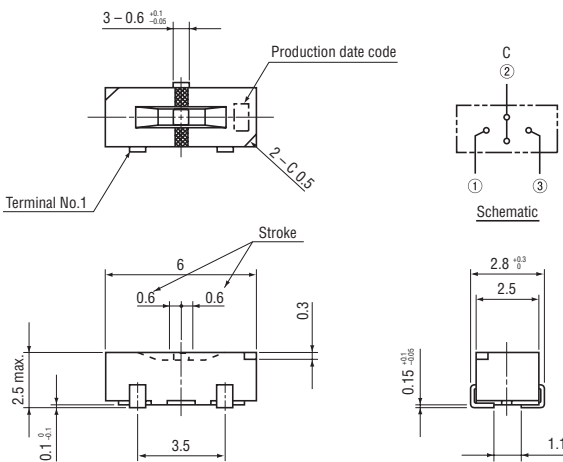

● CJS-1201B1

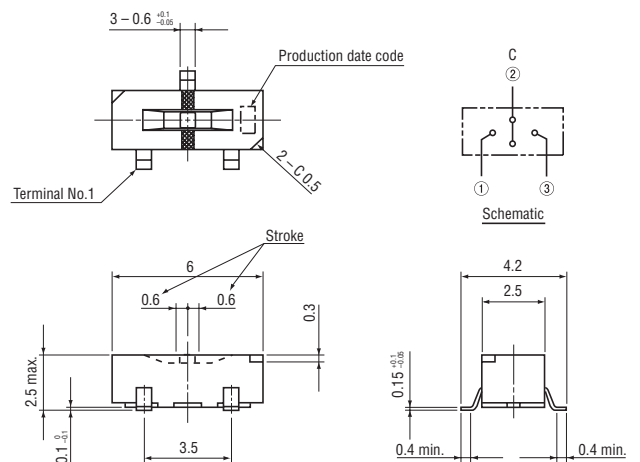

RECOMMENDED P.C.B. PAD OUTLINE DIMENSIONS

A type

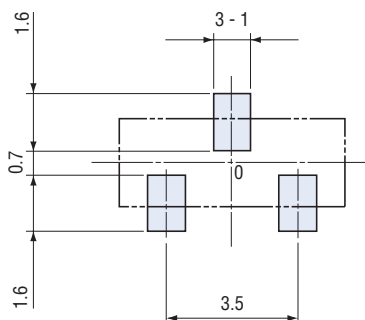

B type

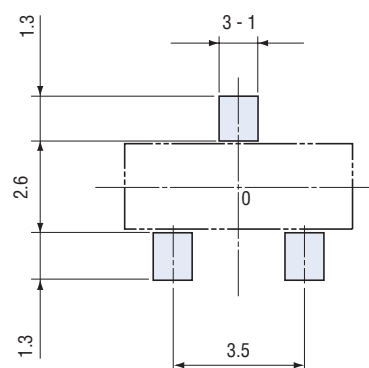

(Unit : mm)

Note) The zero point is the center of mounting.

PACKAGING SPECIFICATIONS

<Taping packaging specifications>

- Taping version is packaged in 1000 pcs. per reel.
Orders will be accepted for units of 1000 pcs., i.e., 1000, 2000, 3000 pcs., etc.
- Taping version is boxed with two reels (2000 pcs.).

Maximum number of consecutive missing pieces=2
Leader length and reel dimension are shown in the diagrams below:

● Embossed tape dimensions

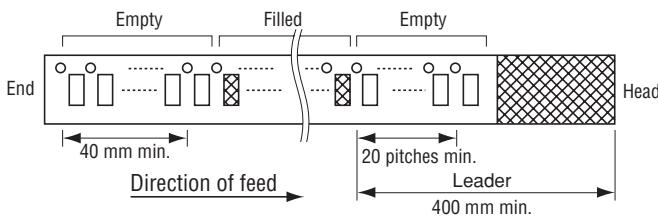

● Reel dimensions

(Unit: mm)
(Conforms to JIS C 0806)

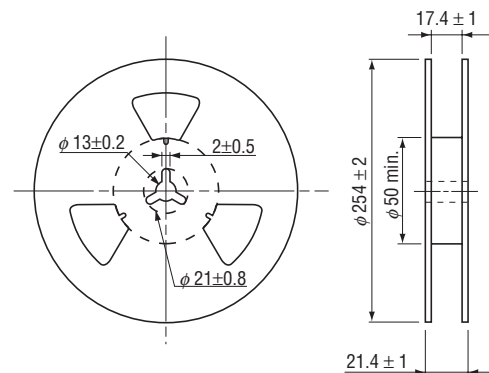

● CJS-1200TA□, 1200TB□, 1201TA□, 1201TB□

(Unit: mm)
(Conforms to JIS C 0806)

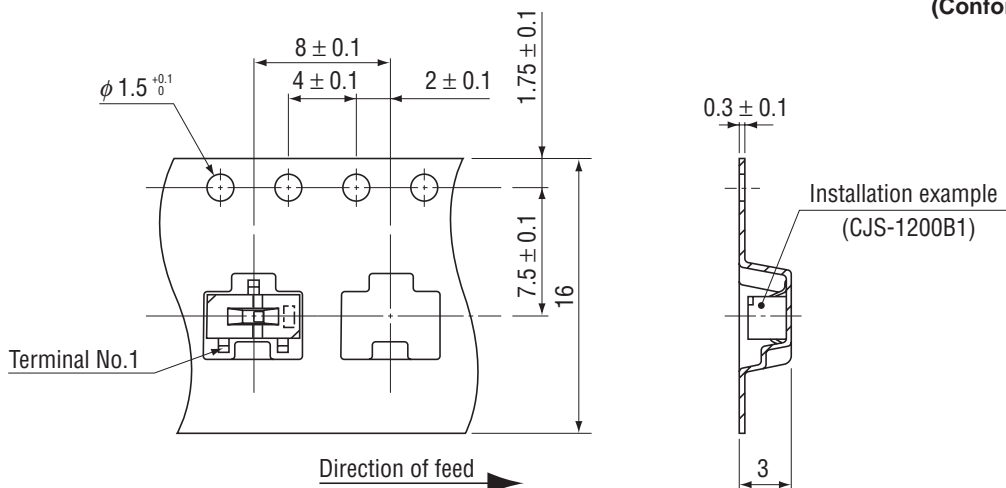

<Bulk pack specifications>

- Boxing of bulk pack in a plastic bag is performed with 100 pcs. (standard 500 pcs.) per box.