

SmartFan® Fusion-4

Speed Control and Alarm for DC Fans

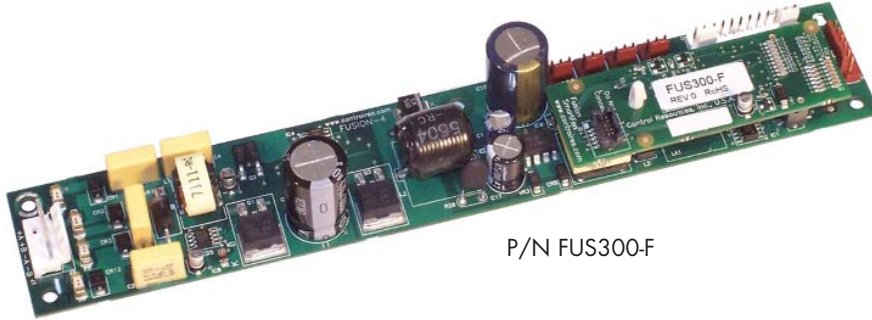

P/N FUS300-F

DC
Controls

SmartFan Fusion-4 is a digital fan speed control and alarm that offers an off-the-shelf cooling solution for DC Fans and blowers including ATCA compliance for managed or intelligent FRU cooling systems. In order to fully meet the telecommunication industry's first open standard for carrier-grade systems, the Fusion will communicate with shelf management modules via dual IPMBs as specified by AdvancedTCA PICMG 3.0. The control will provide FRU information, individual fan status and temperature readings. The Fusion accepts speed control commands and regulates fan speed using a buck regulator control circuit. The Fusion can also be configured to control fan speed based on temperature, I2C commands (single or dual) or analog control signal (PWM, 5.0 VDC). Configuration of the Fusion is settable via I2C interface or options can be set at the factory to your specifications.

FEATURES

- Power Source: 36 to 75 VDC, single or dual (diode OR'd) power feeds
- Current Rating: 3 Amps @ 55°C
- Fans: Up to four 24 VDC fans
- Includes hot-swap active inrush controller with UVLO/OVLO
- Each input power line is fused to protect against over current conditions,
- Voltage adjustment is accomplished with a current mode buck control circuit.
- High power efficiency, typically greater than 90%
- On-board 3.3 VDC isolated power is provided for the I2C bus and control signal interfaces.
- Monitors open collector or voltage source tach pulses from the fans and provides OR'd outputs to drive LED, and logic alarms
- Narrow 1.50" width of the board allows for mounting in fan trays as thin as 1U (1.75") high
- RoHS Compliant

OPTIONS

- Configurable options via I2C bus:
 - 1 to 4 fan operation
 - Control fan speed based on:
 - Temperature
 - Single or Dual I2C communication
 - Dual IPMB communication for ATCA compliance
 - Read pass/fail status for each fan
 - Read temperature from an on-board thermistor
 - Allow access to EEPROM storage
- Individual fan fusing
- Managed or intelligent FRU ATCA compliance
- OR'd MOS Relay and LED alarm outputs for fan failure, over temperature, sensor failure, microcontroller failure and loss of power to the Fusion
- 12 or 48 VDC fan operation
- Control fan speed based on Analog Control Signal (PWM, 0-5 VDC)



SmartFan[®] Fusion-4

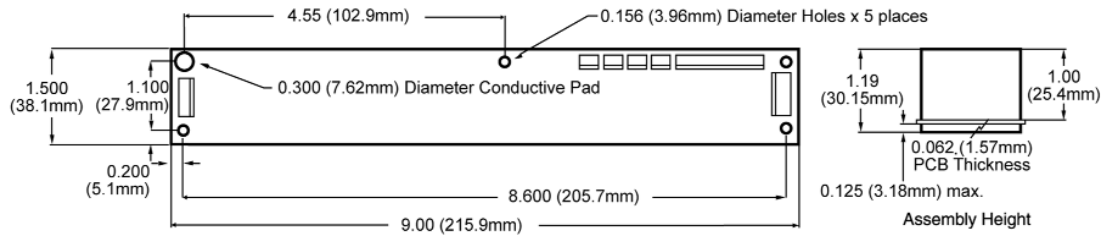

P/N FUS300-F

SPECIFICATIONS

- Power Source: 36 to 75 VDC, single or dual (diode OR'd) power feeds
- Current Rating 3 Amps @ 24 VDC
- Active Current Limit: 10 Amps with 48 VDC applied
- UVLO: Turn on @ 34 VDC, turn off below 30 VDC
- OVLO - 78 VDC (+/- 3 VDC)
- On-Board Isolated Power: 3.3 VDC
- Storage temperature: -40°C to 125°C
- Operating Temperature: -20°C to 55°C
- Relative Humidity: 95% non-condensing
- Weight: 3.6 oz. (102 grams)
- RoHS (6/6) Compliant
- Agency approvals pending



Fusion-4 Datasheet

FEATURES

Input Power: The Fusion-4 can accept one or two power sources in the range of 36 to 75 VDC. If two power supplies are used, they are logically OR'd so that the operating voltage is equal to the higher of the two supplies. The Fusion-4 can supply up to 3 amps to the fan load, at 24 VDC at 55°C.

Fan Speed Control: The speed of all fans is varied by adjusting the fan voltage. Voltage adjustment is accomplished with a current mode buck control circuit. The fan voltage range is 0,12-24 VDC for 24 VDC fans.

Active Current Limiting: The load regulating circuitry is configured with an active current limit, which limits to current to 10A with 48 VDC applied. The current is delayed and instant off to prevent arcing of contacts during live insertion. The inrush circuit has a turn-on voltage of 34 VDC and a turn-off voltage of 30 VDC. The regulator is equipped with a soft start circuit to limit start-up currents. Chart 1.0 shows a typical insertion current with a 48 VDC supply.

Typical Inrush Current

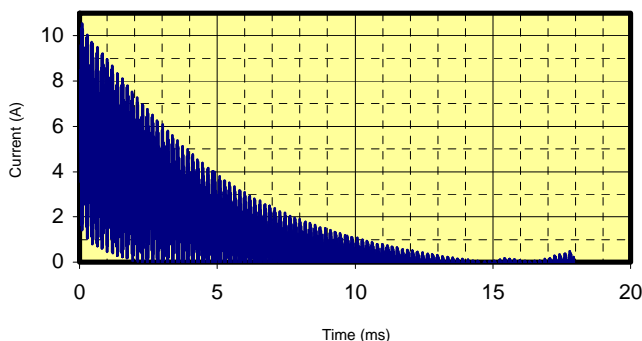

Chart 1.0: Inrush Current with 48VDC Input Applied

Input Power Fuse: 3 Amp fuses are provided for each (four) input power line to protect the Fusion-4 from over-current conditions and meet ATCA requirements.

Number of Fans: The Fusion-4 can be configured to power and monitor 1 to 4 fans.

Fan Control Methods: Two methods of controlling the speed of the fans are settable via the I2C Bus: temperature sensor (thermistor) input or I2C bus input. Following is a description of each control method:

1) Temperature Based Fan Control: The speed of all fans is proportional to the temperature sensor connected to header J12, or the temperature of the board mounted sensor. Chart 2.0 shows fan voltage as a function of sensed temperature. I2C bus register 0xF9 is used to set the control temperature, T_C (The control temperature is the temperature at which full supply voltage is applied to the fans.). Temperature sensor status and temperature readings are available on the I2C bus.

Fan Voltage vs. Sensed Temperature

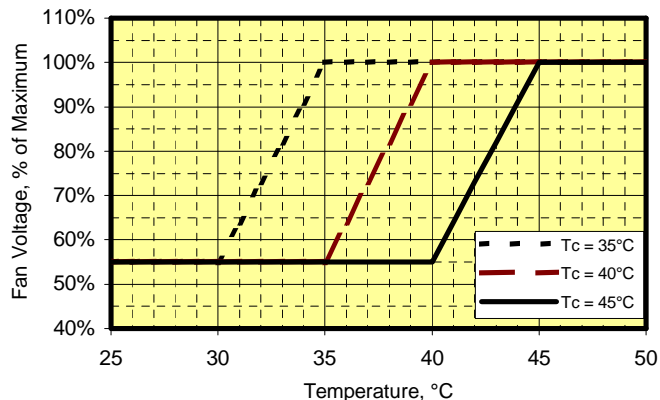

Chart 2.0: Fan voltage vs. sensor temperature examples (5deg slope).

2) I2C Bus Based Fan Control: When an I2C speed command is given, the Fusion-4 automatically switches to I2C control mode for fan control via the I2C bus. The speed of all fans is mapped to the command sent through the I2C on header J12. See the Operation Section for a full definition of the I2C protocol.

Temperature Sensors: When temperature sensor based fan control is specified, the user can choose the remotely mounted sensor or the board mounted sensor.

Selectable Control Temperature and Slope: When temperature sensor based fan control is specified, the user can set the control temperature and choose a 5°C or 10°C slope via the I2C bus.

Selectable Off Temperature: When temperature sensor based fan control is specified, the user can select an off temperature, which will turn off the regulator when the temperature drops below the set point.

Selectable Alarm Temperature: When temperature sensor based fan control is specified, the user can set the alarm temperature. When the temperature exceeds the alarm temperature, an alarm is triggered and full supply voltage is applied to the fans.

On Board Power Supply: An isolated 3.3 VDC is provided on board to power the I2C bus and control signal interfaces.

Fusion-4 Datasheet

ATCA Features: The Fusion-4 hardware was designed to be compatible with connections to the IPMB of an ATCA chassis. The following features have been included.

- Input control over inrush with UVLO/OVLO with I2C control capability
- Diode and fusing on all four input leads
- Dual full-time I2C multi-master capable bus controllers
- NPX PCA9511 I2C hot-swap controllers
- EEPROM storage capability through dual I2C Busses
- Full 7 bit settable I2C addressing
- On-board temperature sensing
- Fan speed monitor capability
- Hot-swap latch switch input
- LED outputs for green, red, yellow and blue LED's
- Watchdog capability for safe I2C communications
- Regulator off command through I2C bus
- Local temperature control options

The standard Fusion-4 firmware and hardware is compliant with a managed FRU configuration and can be used as a stand alone temperature controller, single I2C controller, or dual I2C controller. For intelligent FRU or other customized configurations please contact Control Resources' application engineering.

Standard Configuration of the Fusion-4

The Fusion-4 is intended to be configured via an I2C bus. If no I2C bus is connected the Fusion-4 will default to temperature based speed control as follows.

- Temperature is monitored by the remote sensor
- Control (full speed) temperature is 40°C
- Temperature slope is 5°C
- Idle speed (temperature below 35°C) is ~13 VDC
- Fan alarm is set at 2000 PPM with 4 fans
- LED and MOS alarms are active for fan alarms and external sensor failure (open).

If your system does not utilize an I2C bus and the temperature control parameters above do not meet your needs, the Fusion-4 can be configured at the factory for special temperature control parameters. Contact Control Resources' application engineering for assistance.

Specialized Configurations of the Fusion-4

The following parameters can be specialized through software modification:

- Control for 12 VDC or 48 VDC fans
- Relationship between sensed temperature and fan voltage
- Additional temperature sensor inputs
- Analog control input (voltage / PWM control)
- Fan speed control based on differential temperature
- Fan speed alarm trigger point
- I2C bus status register

Customized Configuration of the Fusion-4

Contact Control Resources' application engineering with special or custom requirements.

INSTALLATION

Mounting

Using the PCB support hardware in hardware pack H124-F, or equivalent, mount the Fusion-4 on a flat surface using all six mounting holes for maximum support. To minimize EMI, securely mount the unit on a grounded surface using a metal spacer and hardware at the mounting hole that is surrounded by a conductive pad.

Connector Pin Assignments:

A description of the function of each connector pin and location is listed in Table 1.0. Depending on the model number and configuration of the Fusion-4, some headers may not need to be populated.

Table 1.0: Connector Pin Assignments		
Header	Label	Description
J1	+A	Power Supply A, Positive Terminal
	+B	Power Supply B, Positive Terminal
	-A	Power Supply A, Negative Terminal
	-B	Power Supply B, Negative Terminal
J3- J6	+	Fan, Positive Terminal
	A	Fan, Tachometer Signal
	-	Fan, Negative Terminal
J12	1	I2C Address A0
	2	I2C Address A1
	3	I2C Address A2
	4	Speed Override Input
	5	Not Used
	6	Not Used
	7	External Thermistor Input
	D1	SDA for Secondary I2C Bus
	C1	SCL for Secondary I2C Bus
	D0	SDA for Primary I2C Bus
	C0	SCL for Primary I2C Bus
J13	GND	Isolated/Logic Ground
	1	Alarm LED Output
	2	Not Alarm LED Output
	3	Power LED Output
	4	Isolated Alarm Contact 1
	5	Isolated Alarm Contact 2

Fusion-4 Datasheet

Suggested Connecting Hardware

Use CRI Hardware Pack H123-F containing the following components shown in Table 2.0.

Table 2.0: Recommended Hardware				
Header	Mfg. & P/N	H124-F Hardware Pack		
		Qty	Description	Mfg. & Part No. ¹
J1	Molex No. 26-60-4040	1	Housing	Molex No. 09-50-8041
		4	Terminal (tin)	Molex No. 08-50-0106
J3 - J6	Molex No. 22-29-2031	6	Housing	Molex No. 22-01-3037
		18	Terminal (gold)	Molex No. 08-55-0102
J12	Molex No. 22-29-2121	1	Housing	Molex No. 22-01-3127
		12	Terminal (gold)	Molex No. 08-55-0102
J13	Molex No. 22-29-2061	1	Housing	Molex No. 22-01-3067
		6	Terminal (gold)	Molex No. 08-55-0102
Mounting Hardware		5	PCB Support	Richco No. CBS-4-19
		1	Aluminum Spacer	Richco No. ALSS6-2
		1	Screw	6-32 x 5/8
		1	Nut	6-32

¹ Or equivalent

Input Power Connection to Header J1

Refer to Figure 1.0 for input power wiring. One or two power supplies in the range of 36 – 75 VDC should be connected at header J1. The Fusion-4 can supply up to 3.0 Amps (still air) at 24 VDC to the fan load at 55°C.

Fan Connection to Headers J3-J6

Four Fans: The Fusion-4 distributes power to and monitors the tachometer signals from four three-wire fans. Referring to Figure 1.0, connect the fans to headers J3 through J6. Fan wires are usually color coded with red for +, black or blue for - and white or yellow for tachometer signal. Fan current at each fan header must not exceed 3.0 Amps. Total current required by the fans connected to the Fusion-4 must not exceed 3.0 Amps (still air) at 24 VDC.

Less than Nine Fans: Through the I2C, each fan header may be disabled. When disabled, the alarm outputs associated with that fan header will always show no alarm.

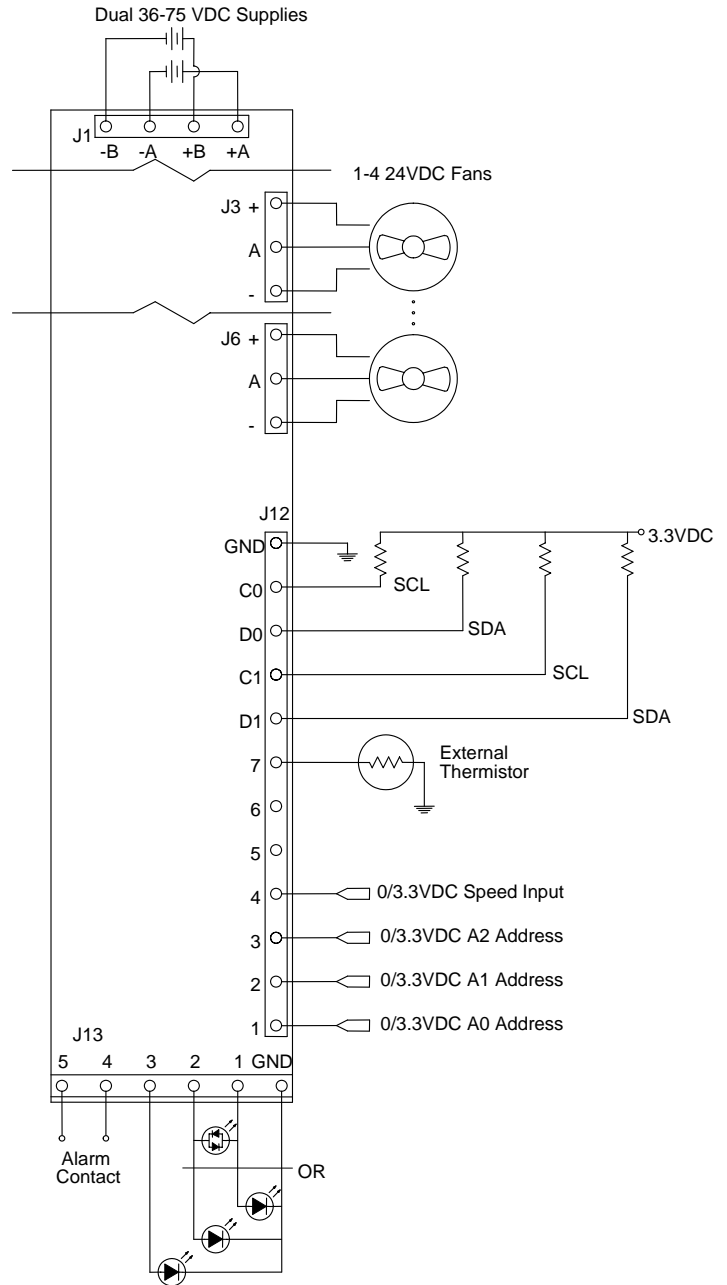

FIGURE 1.0: Connection diagram showing input power, fan, interface, temperature sensor, LEDs and alarm connections for a Fusion-4 Fan Control.

Connection of Remote Temperature Sensor to header J12

Temperature Sensor Connection when I2C Control is used: When configured to operate with I2C based speed control, temperature readings from both sensors are available. These temperatures do not affect speed or alarms in this control mode.

Fusion-4 Datasheet

Temperature Sensor Control: The Fusion-4 can be configured to operate with either an external sensor or the on-board sensor, which is used to provide temperature based fan speed control and alarming. Referring to Figure 1.0, connect the external sensor if used to header J12. There is no polarity consideration when connecting the sensor. Temperature accuracy and hysteresis is 2°C.

Connection of Dual I2C Bus to Header J12

I2C Bus Speed Command Inputs when Temperature Sensor based Fan Control is used: When configured for temperature sensor based fan control, header J12 will accept I2C commands from either I2C bus. If a speed control command is given the Fusion-4 will automatically switch to I2C based speed control mode. Temperature sensor based fan control configurations support all I2C alarm status registers.

Dual I2C Bus: The Fusion-4 uses 3.3 VDC bus operation. The SCL (Pin Cx) and SDA (Pin Dx) are buffered with a NPX PCA9511, which allows hot-swapping the I2C buses and uses internal rise time accelerators for improved performance. The total pull-up must be limited to 3 mA and bus capacitance limited to 400 pf per the I2C specification. If only one I2C bus is required either connection may be used. If two conflicting commands are given on each bus at the same time the command from the Primary bus will be used (S0 & D0).

Digital Inputs: The Speed input (Pin 4) and the ID inputs (Pins 1 - 3) are internally pulled to 3.3 VDC with 10.0KΩ resistors.

GND (Pin GND): Ground reference pin for the I2C busses and Digital inputs.

Connection of LEDs to Header J13

Header J13 provides local indication of Alarm (Pin 1), Normal (Pin 2), and Power (Pin 3) status. Referring to Figure 1.0, connect alarm LEDs to header J13. **All LEDs are referenced to the Digital Ground (Pin GND).** Choose single color LEDs or two leaded, bi-color LEDs with a rated forward voltage (V_f) between 1.6 and 2.4 VDC at a forward current (I_f) of between 15 and 25 mA. Nominal current applied to the LEDs is 8 mA.

Connection of Remote Alarm Circuits to Header J13

A MOS relay is provided on header J13 Pins 4 and 5 to provide remote indication of alarm status. Referring to Figure 1.0, connect logic circuits to header J7. The alarm circuit on header J13 is isolated from all other pins.

OPERATION

Remote Sensor Selection (J12)

When configured to operate with a remote external temperature sensor, choose a compatible SmartFan Sensor shown in the SmartFan Catalog or at www.controlres.com/sensors.htm. Control temperature is set through the I2C bus.

Board-Mounted Temperature Sensor

In this configuration, fan voltage is proportional to the temperature at the sensor that is soldered to the Fusion-4. Control temperature is set through the I2C bus.

Fan Tachometer Setting

Since fan tachometer circuits are designed with one, two or even more pulse outputs per revolution, settings are listed in pulses per minute (PPM) rather than revolutions per minute (RPM). Given the fan's speed under load (W) and the number of pulses per revolution (N), use the following formula to select the trigger speed (W_A):

$$W_A = W \times N \times 0.3$$

For example, a 3300-RPM fan with two pulses per revolution would have a trigger speed of

$$W_A = 3300 \text{ RPM} \times 2 \text{ PPR} \times 0.3 = 1980 \text{ PPM.}$$

Since the 2000 PPM trigger is closest, set tachometer speed to 2000 PPM.

The alarm trigger accuracy is +/- 10%.

The Fusion-4 default factory setting is 2000 PPM.

Led Output Status Operation (J13)

LED outputs at J13 pins labeled 1, 2 and 3 are provided as follows:

LED1 is energized for any fault condition.

LED2 is energized when no fault is present.

LED3 is energized when the Fusion is powered.

Two leaded and three leaded (common cathode) bi-colored LEDs can also be used.

Alarm Logic (J13)

A single isolated Alarm output is provided on J13. The output is low resistance when there is no alarm and open during any alarm condition. The output is current limited to 100mA with an open voltage of 230 VAC/VDC.

Fan Voltage in any Alarm Condition

During the presence of any alarm condition, the full 24VDC voltage is applied to the fans.

Speed Override Input (J12 – Pin 4)

A logic level input is located on J12 that allows the user to command the fans to full speed when a ground level is applied. If this input is set to 3.3 VDC or open then the speed is set by its normal operating mode. Refer to Figure 1 for wiring details.

Fusion-4 Datasheet

I2C Bus Protocol

The I2C bus is configured as a slave device that can transmit and receive data. When the Fusion-4 is configured for I2C based speed control, the user can write speed commands to the Fusion-4 and read all alarm status bits. When configured for temperature based control the user can read all alarm status bits from the Fusion-4. Writing an I2C speed command changes the control mode from temperature based to I2C based.

Specifications

- The bus supports seven-bit addressing and only acts as a slave device.
- The address for the fan controller is 0001A2A1A0.
- General call support is not provided.
- The fan controller will stretch the clock further if needed. The I2C master must observe clock stretching.
- The hardware register will support Standard Mode I2C with speeds up to 100 KHz, however, lower clock speeds are recommended for increased noise immunity.
- If temperature control mode is disabled and I2C speed mode is used, then I2C communication must occur within ~2 minutes of the last communication, or there will be an I2C communication timeout error. When an I2C timeout occurs, full supply voltage will be applied to the fans, and fan speed must be reset with a new speed command. Performing any valid I2C operation on either bus will clear the timeout condition and restart the watchdog timer.
- Fan failure based on 2000 minimum PPM of fan in slow (default) mode or 4000 minimum PPM in fast mode. Fan failure is not updated when the output is set to 0 VDC.
- It is possible for noise to cause the I2C hardware to miss an address or data. In this case an Ack will not be generated. The production tester allows 3 errors to occur before marking the board as failing. Also during the EEPROM write cycle the I2C will not generate ACK signals as no more data can be accepted until the write cycle is complete. Typical write cycle is 8ms.

Table 3.0 defines the bits used in the serial bus protocol.

Table 3.0: I ² C Bus Definitions	
ACK	Acknowledge
ACK	Not Acknowledge (End of Transmission)
A6 – A0	Address for Fan Controller, bits 6 – 0
D7 – D0	Data TO/FROM Fan Controller, bits 7 – 0
L7 – L0	Data location being accessed, bits 7-0
P	Stop Bit
R	Read Bit (1)
S	Start Bit
W	Write Bit (0)

Write sequence

S A6 A5 A4 A3 A2 A1 A0 W Ack L7 L6 L5 L4 L3 L2 L1 L0
Ack D7 D6 D5 D4 D3 D2 D1 D0 Ack P

Read sequence

S A6 A5 A4 A3 A2 A1 A0 W Ack L7 L6 L5 L4 L3 L2 L1 L0
Ack P S A6 A5 A4 A3 A2 A1 A0 R Ack D7 D6 D5 D4 D3 D2
D1 D0 Ack P

Register Locations: L7-L0 Label (R/W) [initial condition]

Register 0x00 – 0xEF: Generic EEPROM storage (Read/Write) [undetermined]

Register 0xF0: Firmware Revision (Read only) [00:current rev]

Register 0xF1: Alarm0 Status (Read only) [0x00]

D0: Status of fan of 1 (0=no fault, 1= fault)

D1: Status of fan of 2 (0=no fault, 1= fault)

D2: Status of fan of 3 (0=no fault, 1= fault)

D3: Status of fan of 4 (0=no fault, 1= fault)

D4: Always 0

D5: Always 0

D6: Always 0

D7: Always 0

Register 0xF2: Alarm1 Status (Read only) [0x00]

D0: Always 0

D1-3: Always 0

D4: Status of speed override (0=normal, 1=24VDC)

D5: Status of on-board sensor (0=connected, 1= open)

D6: Status of external sensor (0=connected, 1=open)

D7: Status of controlling sensor (0=valid, 1=alarm)

Register 0xF3: Temperature (Read only) [1111 1111] on-board sensor

D0-7: Temperature from 0 - 70 in degrees C in 0.5 deg steps

0XFF = temperature not read yet or open

(Temperatures above 70 are reported as 254)

Register 0xF4: Temperature (Read only) [1111 1111] external sensor

D0-7: Temperature from 0 - 70 in degrees C in 0.5 deg steps

0XFF = temperature not read yet or open

(Temperatures above 70 are reported as 254)

Register 0xF5: Current Target Speed (Read only) [0000 1100]

D0-7: 0x0C = 24 VDC, 0x00 = 12 VDC

(Commanded speed with alarm status override included)

(In temperature mode this register will read 0x0C)

Register 0xF6: Current Speed (Read only) [0000 1100]

D0-7: 0x0C = 24 VDC, 0x00 = 12VDC

(What the actual current voltage is)

(In temperature mode this register will read 0x0C)

Fusion-4 Datasheet

Register 0xF7: Commanded Speed (Read/Write) [1111 1111]
D0-3: 0x0C = 24 VDC, 0x00 = 12VDC, 0x0F = off
0x00 – 0C = 12 – 24 VDC, 1VDC per step
If set to 0xFF then temperature mode is enabled and I2C speed control disabled

Register 0xF8: Off Temperature (Read/Write) [1111 1111]
D0-7: Temperature from 0 - 70 in degrees C in 0.5 deg steps
Temperature below which the controller turns off the fan output (0 VDC)
If set to 0xFF then function disabled

Register 0xF9: Control Temperature (Read/Write) [0101 0000]
D0-7: Temperature from 0 - 70 in degrees C in 0.5 deg steps
Full speed temperature, only used if Commanded Speed set to 0xFF.

Register 0xFA: Alarm Temperature (Read/Write) [1111 1111]
D0-7: Temperature from 0 - 70 in degrees C in 0.5 deg steps
Temperature above which the controller alarms
If set to 0xFF then function disabled

Register 0xFB: Config0 Register (Read/Write) [0000 1111]
D0-D3: 0=Mask, 1=Active for an Fan (J3-J6)
D4-D7: Not Used

Register 0xFC: Config1 Register (Read/Write) [0000 0000]
D0: Not Used
D1-D4: Set to 0, may be set to 1 to allow system to indicate a fan controller reset.
D5: 0=5deg slope, 1=10 deg slope for temperature mode only
D6: 0=2000PPM tach, 1=4000PPM tach fan alarm speed
D7: 0=External, 1=On-board sensor selection for temperature mode only

Register 0xFD-0xFF: CRI Test Register (Reserved) [xxxx xxxx]
D0-7: Do not use

Note: If a fan failure occurs the Current Speed will be updated to 24V but the Commanded Speed will remain at its previous value. Once the failure clears the Current Speed will return to the Commanded Speed value. An I2C timeout changes BOTH the Current Speed and Commanded Speed to 24V. The Commanded Speed must be reset after a timeout. During the speed ramp the Current Speed will not match the Commanded Speed until the ramp completes.