

2-Color Display Digital Pressure Switch



Stainless diaphragm

Oil-free (Single-layer diaphragm structure)

Sensor parts: **Stainless steel 630**

Fitting parts: **Stainless steel 304**

The sensor and fitting parts can be made to order with stainless steel 316L.

IP65 compliant



2-color display

Irregular value at a glance



3-step setting

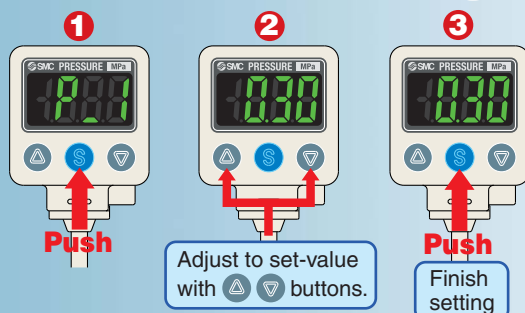

Choice of 2 piping directions

Rear ported

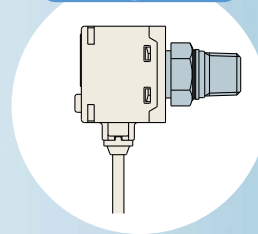

Bottom ported

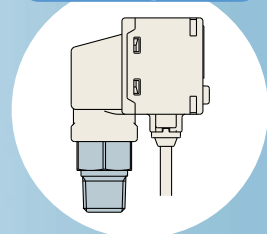

Rated pressure range

0.0 to -101.0 kPa and -0.100 to 2.00 MPa introduced to series

RoHS compliant

Series **ZSE80/ISE80**



CAT.ES100-71A

Leakage

$1 \times 10^{-10} \text{ Pa}\cdot\text{m}^3/\text{s}$

<VCR®- and Swagelok®-fitting compliant>

$1 \times 10^{-5} \text{ Pa}\cdot\text{m}^3/\text{s}$

<Threaded type (R, Rc, NPT, G)>

- Sensor and fitting parts are electron-beam welded.
- Choice of VCR® or Swagelok® fitting is available.

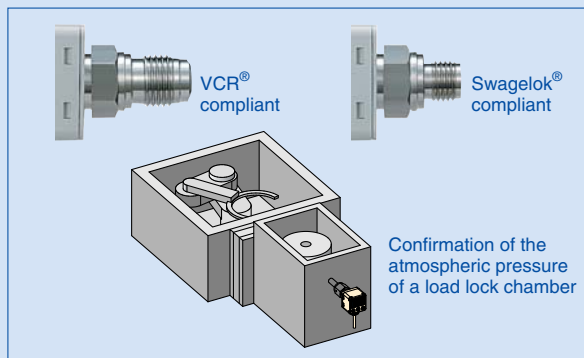

Applicable Fluid Examples

* VCR® and Swagelok® are registered trademarks of Swagelok Company.

- Water
- Hydraulic fluid (JIS-K2213)
- Silicon oil (JIS-K2213)
- Lubricant (JIS-K6301)
- Fluorocarbon
- Argon
- Ammonia
- Carbon dioxide
- Air-containing drainage
- Nitrogen

Applications

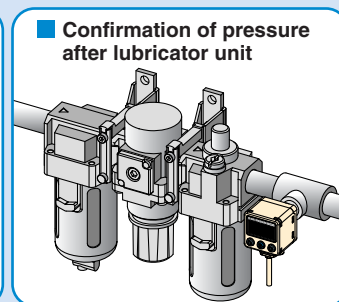
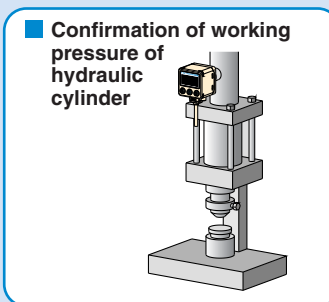
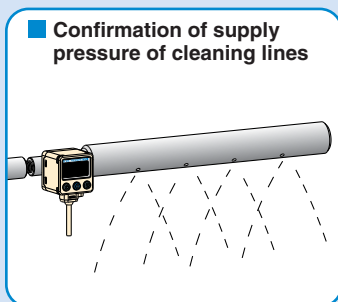
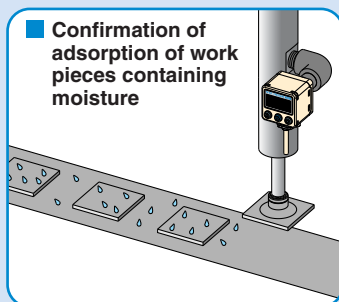

Restrictor installed fitting type (-X510) **Made to Order**

A pressure switch that has a restrictor installed in the fitting is available so that it prevents the sensor from being damaged by water collision with rush inertia. (Refer to page 12 for detail.)

Variations

Series	ZSE80	ZSE80F	ISE80	ISE80H
Easy color distinction by pressure range				
Rated pressure range	0.0 to -101.0 kPa 	-100.0 to 100.0 kPa 	-0.100 to 1.000 MPa 	-0.100 to 2.00 MPa 2 MPa
Withstand pressure	500 kPa		2 MPa	4 MPa
Minimum unit setting	0.1 kPa		0.001 MPa	
Repeatability	±0.2%F.S. ±1 digit			

2-color display (LCD)

Can select from 4 indicator patterns of color combinations.

	ON	OFF
①	Red	Green
②	Green	Red
③	Red	Red
④	Green	Green

Output display

It lights when OUT1 or OUT2 outputs.

Convex rubber button

Convex button is adopted and provides IP65 rating. Improved maneuverability and operability.

Lead wire length

- 2 m (Standard)
- 3 m (Made to Order)

Piping

Rc1/8 (female threaded) is now available.

- R1/4 (M5 x 0.8 female threaded)
- NPT1/4 (M5 x 0.8 female threaded)
- G1/4 (M5 x 0.8 female threaded)

Rc1/8

- URJ1/4 (VCR® fitting compliant)
- TSJ1/4 (Swagelok® fitting compliant)

Output

Analog current output is newly added.

- Advantageous when it is wired for a long distance.
- It is resistant against noise.

- NPN open collector 1 output
- PNP open collector 1 output
- NPN open collector 2 outputs
- PNP open collector 2 outputs
- NPN open collector 2 outputs + Analog voltage output/Auto-shift switching
- PNP open collector 2 outputs + Analog voltage output/Auto-shift switching
- NPN open collector 2 outputs + Analog current output/Auto-shift switching
- PNP open collector 2 outputs + Analog current output/Auto-shift switching

Secret code setting

This ensures that only authorized persons can operate the switch when the key is locked.



Input an arbitrary three-digit value.

* The set-value can be confirmed even when the key is locked.

Resolution switching function

It prevents minor variation of the indicated value.



(Only the indicated value changes without changing precision.)

Power-saving mode

Turning off the display can save power consumption. (Power consumption: Max. 18% reduced)



The numerical value disappears and the decimal points blink.

MPa/kPa switching function

The indication unit for vacuum, compound pressure and positive pressure can be integrated into either MPa or kPa.



Panel mount

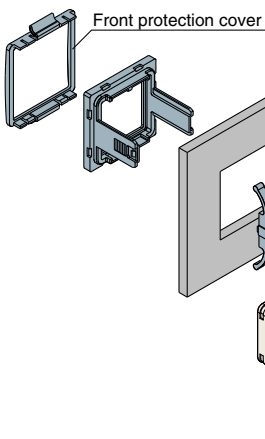

Suitable for side-by-side mounting

- Requires less installation space and panel cutting.

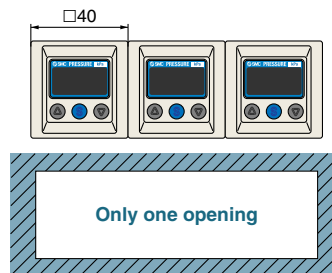

Bracket mount

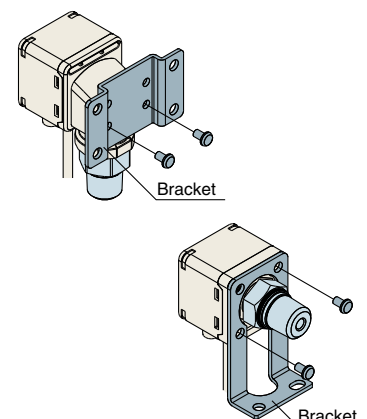

2-Color Display Digital Pressure Switch For General Fluids

Series ZSE80/ISE80

How to Order



For positive pressure

ISE 80 - 02 - N - M

For vacuum/
compound pressure

ZSE 80 - 02 - N - M

Rated pressure range

80	-0.1 to 1 MPa
80H	-0.1 to 2 MPa

Made to Order
Refer to Table 1 below.

Rated pressure range

80	0 to -101 kPa
80F	-100 to 100 kPa

Piping

Symbol	Connection	Porting
02	R1/4 (M5 female threaded)	Rear ported
N02	NPT1/4 (M5 female threaded)	
F02	G1/4 (M5 female threaded)	
C01	Rc1/8	
A2	URJ1/4	
B2	TSJ1/4	
02L	R1/4 (M5 female threaded)	Bottom ported
N02L	NPT1/4 (M5 female threaded)	
C01L	Rc1/8	
A2L	URJ1/4	
B2L	TSJ1/4	

Input/Output

N	NPN open collector 1 output
P	PNP open collector 1 output
A	NPN open collector 2 outputs
B	PNP open collector 2 outputs
R	NPN open collector 2 outputs + Analog voltage output/Auto-shift switching
T	PNP open collector 2 outputs + Analog voltage output/Auto-shift switching
S	NPN open collector 2 outputs + Analog current output/Auto-shift switching
V	PNP open collector 2 outputs + Analog current output/Auto-shift switching



Table 1
Made to Order

Symbol	Specifications
-X500 ^{Note)}	Wetted parts: Stainless steel 316L
-X501	Lead wire length 3 m
-X510	Restrictor installed fitting

Note) Not applicable to the rated pressure range 0 to 2 MPa specification. Refer to page 12 for detail.

Option

Option	Piping direction	Part no.
Bracket	Rear ported	ZS-24-A
	Bottom ported	ZS-35-A
	Bottom ported	ZS-35-D
Panel mount	Rear ported	ZS-35-C
	Bottom ported	ZS-35-B
Panel mount + Front protection cover	Rear ported	ZS-35-F
	Bottom ported	ZS-35-E

Option 3

Symbol	Operating manual ^{Note)}	Calibration certificate	Symbol	Operating manual ^{Note)}	Calibration certificate
Nil	● (Booklet)	—	K	● (Booklet)	●
Y	—	—	T	—	●
W	● (CD-ROM)	—	R	● (CD-ROM)	●

Note) All texts in both English and Japanese

Option 1

Nil	With unit display ^{Note 1)} switching function
M	Fixed SI unit ^{Note 2)}
P	Initial value PSI

Note 1) Under the New Measurement Law, sales of switches with the unit switching function have not been allowed for use in Japan.

Note 2) Fixed unit ISE80H: MPa
Others : MPa, kPa

Option 2

Nil	None
A	With bracket
B	With bracket ^{Note)}
C	Panel mount
D	Panel mount + Front protection cover

Note) Rear ported only

2-Color Display Digital Pressure Switch

For General Fluids *Series ZSE80/ISE80*

Specifications

Model		ZSE80 (Vacuum pressure)	ZSE80F (Compound pressure)	ISE80 (Positive pressure)	ISE80H (Positive pressure)
Rated pressure range		0.0 to -101.0 kPa	-100.0 to 100.0 kPa	-0.100 to 1.000 MPa	-0.100 to 2.00 MPa
Set pressure range		10.0 to -111.0 kPa	-110.0 to 110.0 kPa	-0.105 to 1.100 MPa	-0.105 to 2.20 MPa
Withstand pressure		500 kPa		2 MPa	4 MPa
Wetted parts material		Pressure sensor: Stainless steel 630, Fitting: Stainless steel 304			
Applicable fluid		Fluids do not corrode stainless steel 630 and 304			
Port size		R1/4, NPT1/4, G1/4*, URJ1/4, TSJ1/4, Rc1/8 Piping direction: Rear/Bottom			
Power supply voltage		12 to 24 VDC ±10%, Ripple (p-p) 10% or less (with power supply polarity protection)			
Current consumption		45 mA or less			
Switch output		NPN 1 output, NPN 2 outputs, PNP 1 output, PNP 2 outputs			
Switch output	Maximum load current	80 mA			
	Maximum load voltage	28 V (at NPN output)			
	Residual voltage	1 V or less (with load current of 80 mA)			
	Response time	2.5 ms (with anti-chattering function: 20, 100, 500, 1000, 2000 ms)			
	Short circuit protection	Yes			
Repeatability		±0.2% F.S. ±1 digit			
Hysteresis	Hysteresis mode	Variable (0 or above)			
	Window comparator mode				
Analog output	Voltage output	Output voltage (Rated pressure range)	1 to 5 V ±2.5% F.S.	0.6 to 5 V ±2.5% F.S.	0.8 to 5 V ±2.5% F.S.
		Linearity	±1% F.S. or less		
		Output impedance	Approx. 1 kΩ		
	Current output	Output current (Rated pressure range)	4 to 20 mA ±2.5% F.S.	2.4 to 20 mA ±2.5% F.S.	3.2 to 20 mA ±2.5% F.S.
		Linearity	±1% F.S. or less		
		Load impedance	Maximum load impedance: 300 Ω (Power supply voltage 12 V) 600 Ω (Power supply voltage 24 V) Minimum load impedance: 50 Ω		
Auto-shift input		Non-voltage input (Reed or Solid state), Low level: 0.4 V or less, 5 ms or longer input			
Display		3 1/2-digit, 7-segment, 2-color LCD (Red/Green)			
Display accuracy		±2% F.S. ±1 digit (Ambient temperature of 25 ±3°C)			
Indicator light		Lights up when output is turned ON. OUT1, OUT2: Orange			
Function		Anti-chattering, Zero-out, Key lock function, Auto-preset, Auto-shift, Unit display switching, Power-saving mode			
Environment resistance	Enclosure		IP65		
	Operating temperature range		Operating: 0 to 50°C, Stored: -10 to 60°C (No freezing or condensation)		
	Operating humidity range		Operating/Stored: 35 to 85% RH (No condensation)		
	Withstand voltage		250 VAC for 1 minute between live parts and case		
	Insulation resistance		2 MΩ or more between live parts and case (at 50 VDC Mega)		
	Vibration resistance		10 to 150 Hz at whichever is smaller of 1.5 mm amplitude or 20 m/s ² acceleration, in X, Y, Z directions, for 2 hours each (De-energized)		
Impact resistance		100 m/s ² in X, Y, Z directions, 3 times each (De-energized)			
Temperature characteristics		±3% F.S. (Based on 25°C, within operating temperature range)			
Lead wire		Oilproof heavy-duty vinyl cable, 3 cores (N.P) 4 cores (A.B) 5 cores (R.T.S.V)		ø3.5, 2 m Conductor area: 0.15 mm ² (AWG26) Insulator O.D.: 0.95 mm	
Standards		CE marking, UL/CSA, RoHS compliance			

* G1/4 is available for rear ported only.

Piping Specifications

Model	O2	N02	F02	C01	A2	B2
Port size	R1/4	NPT1/4	G1/4	Rc1/8	URJ1/4	TSJ1/4
Weight (Bottom ported)	117 g	118 g	—	114 g	120 g	111 g
Weight (Rear ported)	89 g	90 g	86 g	86 g	92 g	83 g
Leakage	1 x 10 ⁻⁵ Pa · m ³ /s			1 x 10 ⁻¹⁰ Pa · m ³ /s		

Series ZSE80/ISE80

Analog Output

Voltage output

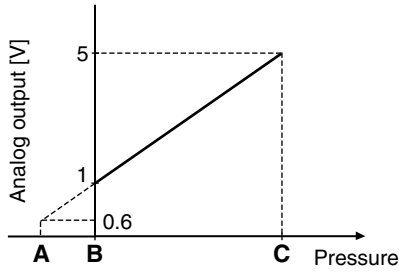

Current output

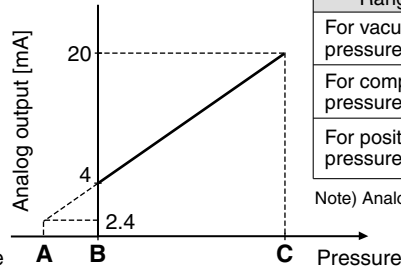

Range	Rated pressure range	A	B	C
For vacuum pressure	0.0 to -101.0 kPa	10.1 kPa	0	-101.0 kPa
For compound pressure	-100.0 to 100.0 kPa	—	-100.0 kPa	100.0 kPa
For positive pressure	-0.100 to 1.000 MPa	-0.100 MPa	0	1.000 MPa
	-0.100 to 2.00 MPa	-0.100 MPa ^{Note)}	0	2.00 MPa

Note) Analog output is 0.8 [V] or 3.2 [mA] at the pressure A.

Descriptions

Output (OUT1) display (Orange)

Lights up when OUT1 is turned ON.

Output (OUT2) display (Orange)

Lights up when OUT2 is turned ON.

△ button

Use this button to select the mode or increase the ON/OFF set-value.
It is also used for switching to the peak display mode.

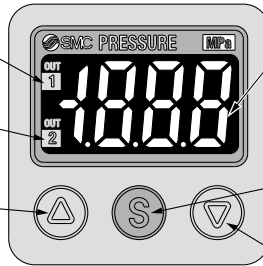

LCD

Displays the current pressure, set mode, selected display unit, and error code. Always use red or green display; or switch between green and red according to the output. Four different display settings are available.

SET button

Use this button to change the mode or confirm the set-value.

▽ button

Use this button to select the mode or decrease the ON/OFF set-value.
It is also used for switching to the bottom display mode.

Internal Circuits and Wiring Examples

-N
NPN (1 output)

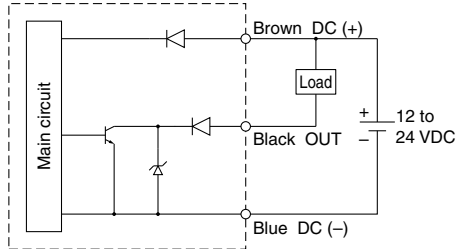

Max. 28V, 80 mA
 Residual voltage 1 V or less

-P
PNP (1 output)

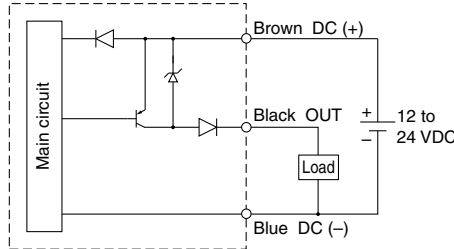

Max. 80 mA
 Residual voltage 1 V or less

-A
NPN (2 outputs)

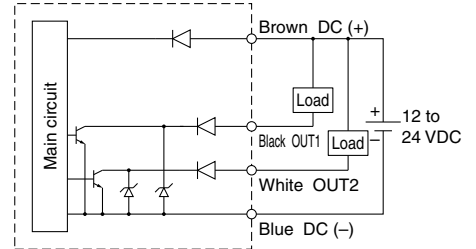

Max. 28V, 80 mA
 Residual voltage 1 V or less

-B
PNP (2 outputs)

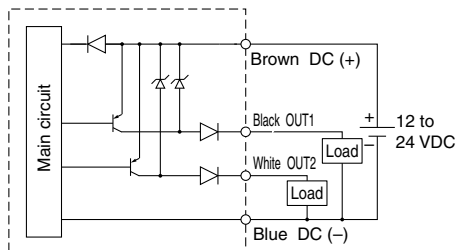

Max. 80 mA
 Residual voltage 1 V or less

-R
**NPN (2 outputs) +
 Analog voltage output**

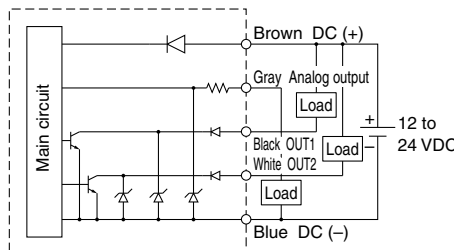

Max. 28V, 80 mA
 Residual voltage 1 V or less

-R-S
**NPN (2 outputs) +
 Auto-shift input**

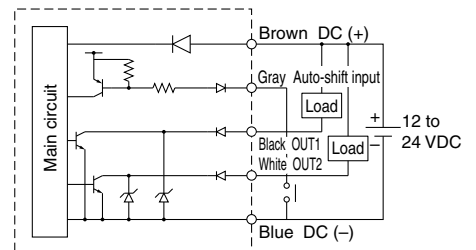

Max. 28V, 80 mA
 Residual voltage 1 V or less

-S
**NPN (2 outputs) +
 Analog current output**

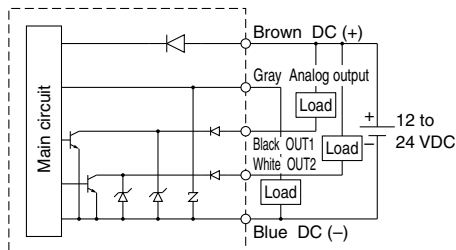

Max. 28V, 80 mA
 Residual voltage 1 V or less

-T
**PNP (2 outputs) +
 Analog voltage output**

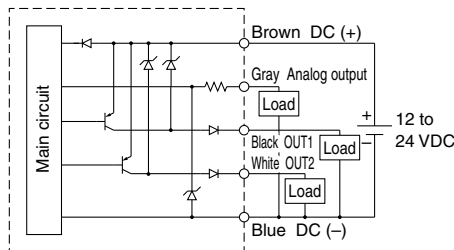

Max. 80 mA
 Residual voltage 1 V or less

-T-V
**PNP (2 outputs) +
 Auto-shift input**

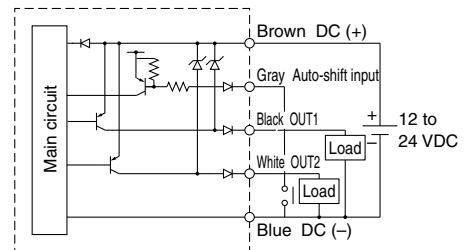

Max. 80 mA
 Residual voltage 1 V or less

-V
**PNP (2 outputs) +
 Analog current output**

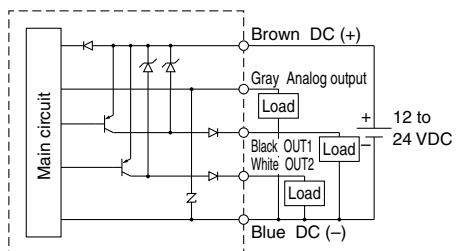

Max. 80 mA
 Residual voltage 1 V or less

Series ZSE80/ISE80

Dimensions

ZSE/ISE80□□-02
 N02
 F02
 C01
 A2
 B2

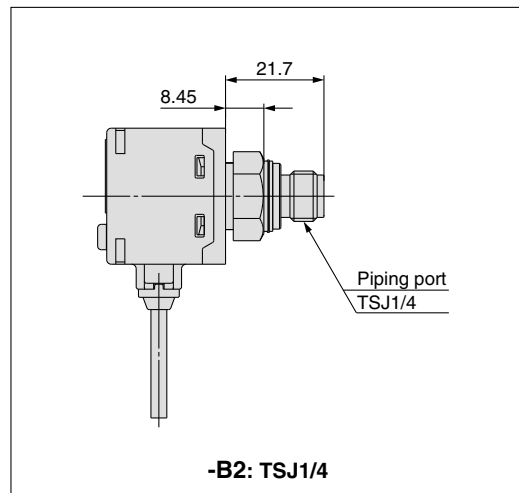
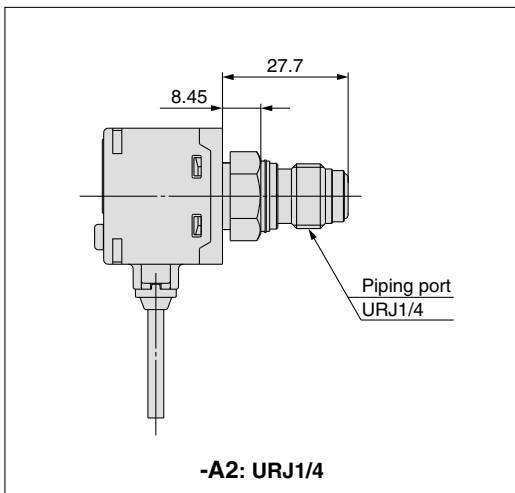
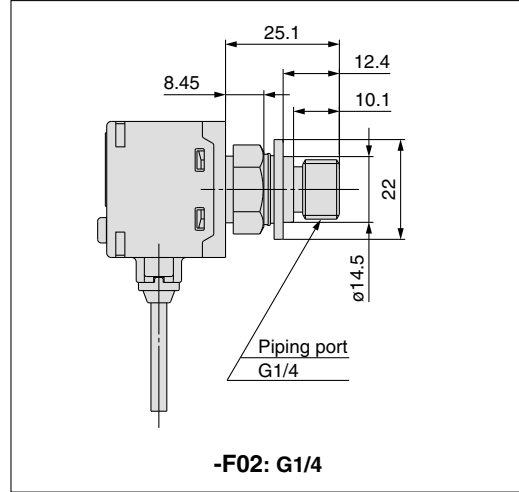
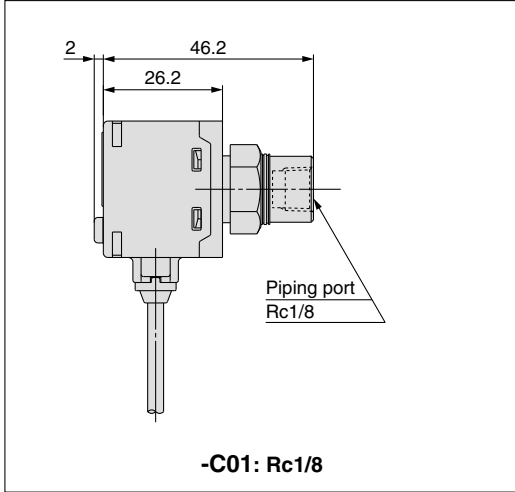
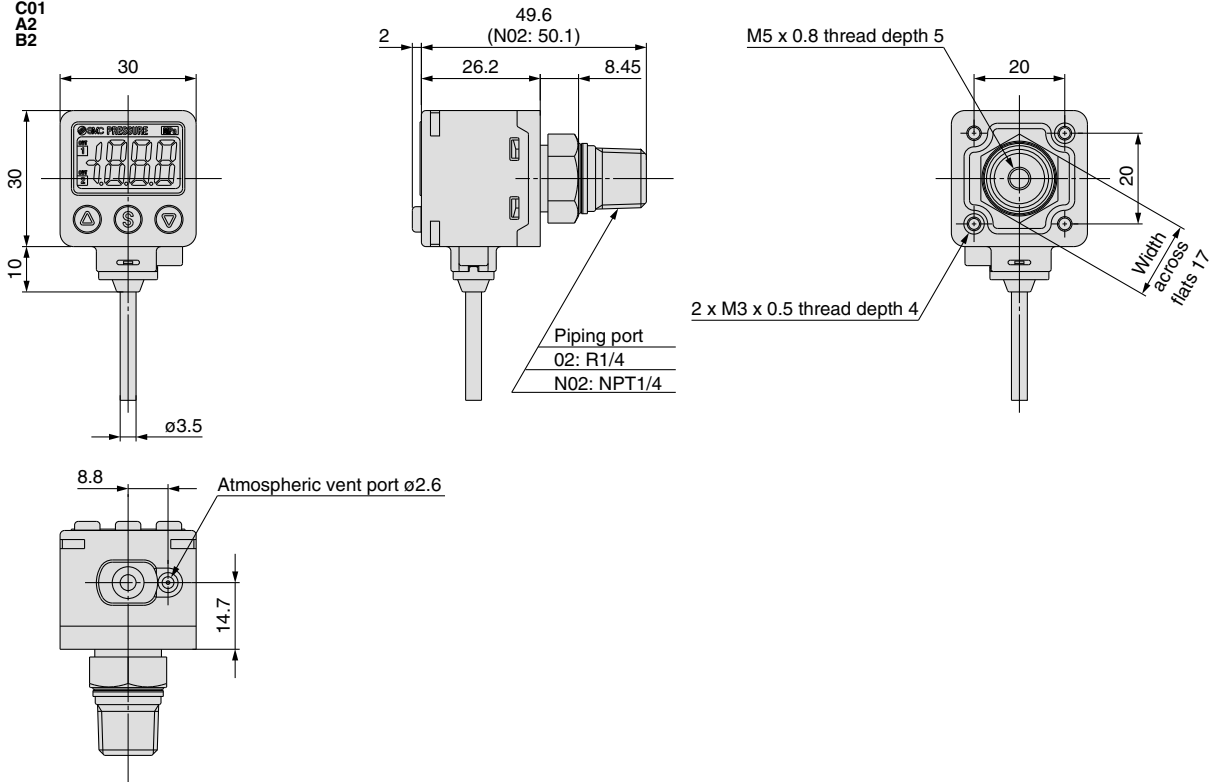

2-Color Display Digital Pressure Switch For General Fluids **Series ZSE80/ISE80**

Dimensions

ZSE/ISE80□□-
 02L
 N02L
 C01L
 A2L
 B2L

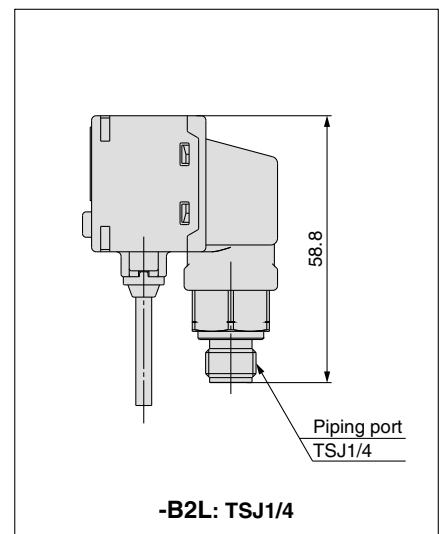
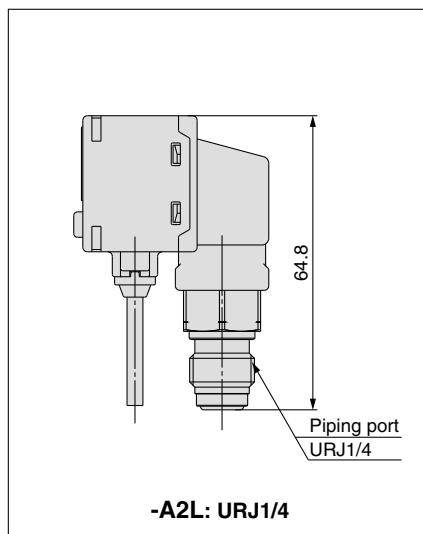
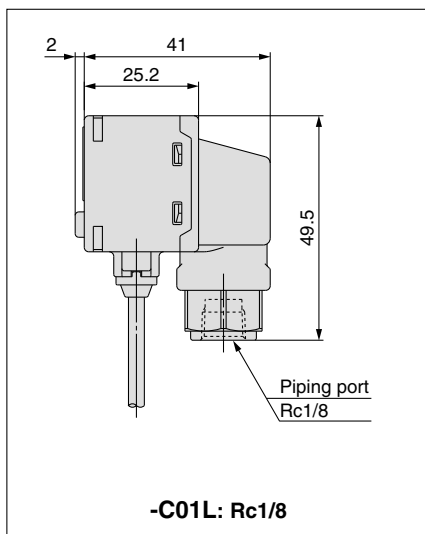
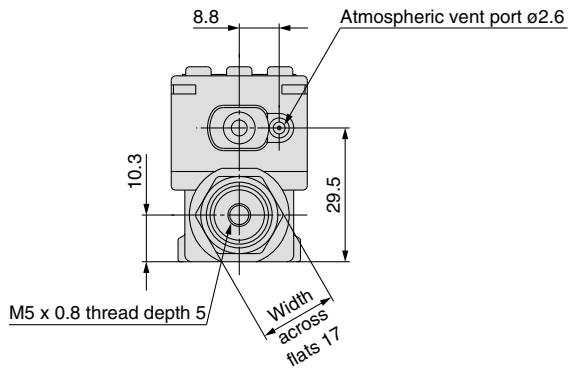
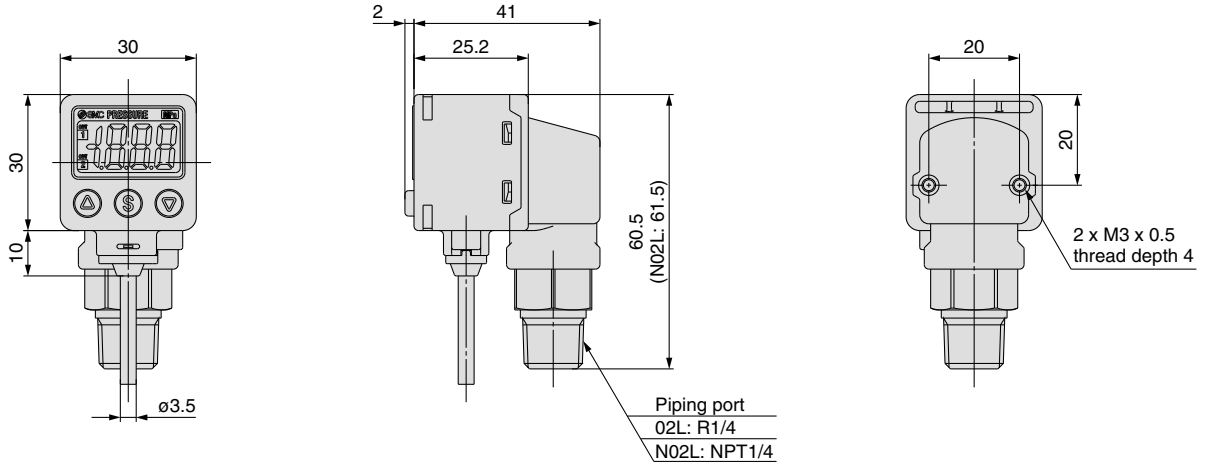

Series ZSE80/ISE80

Dimensions

With bracket (Rear ported)

• ZS-24-A

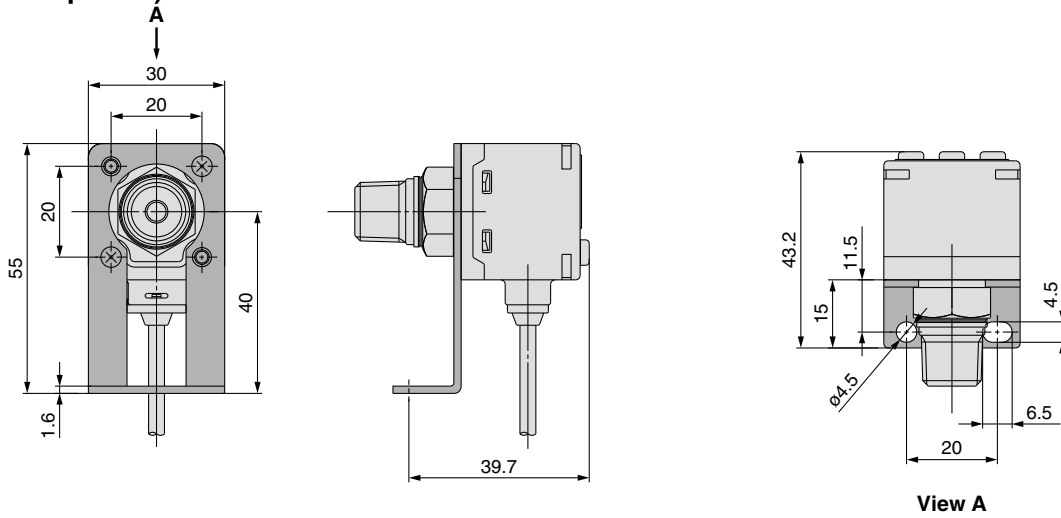

With bracket (Rear ported)

• ZS-24-D

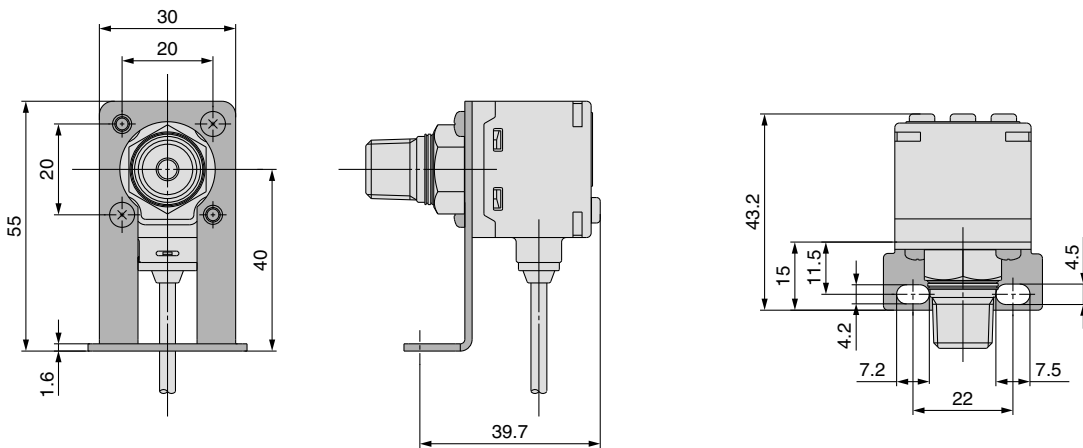

With bracket (Bottom ported)

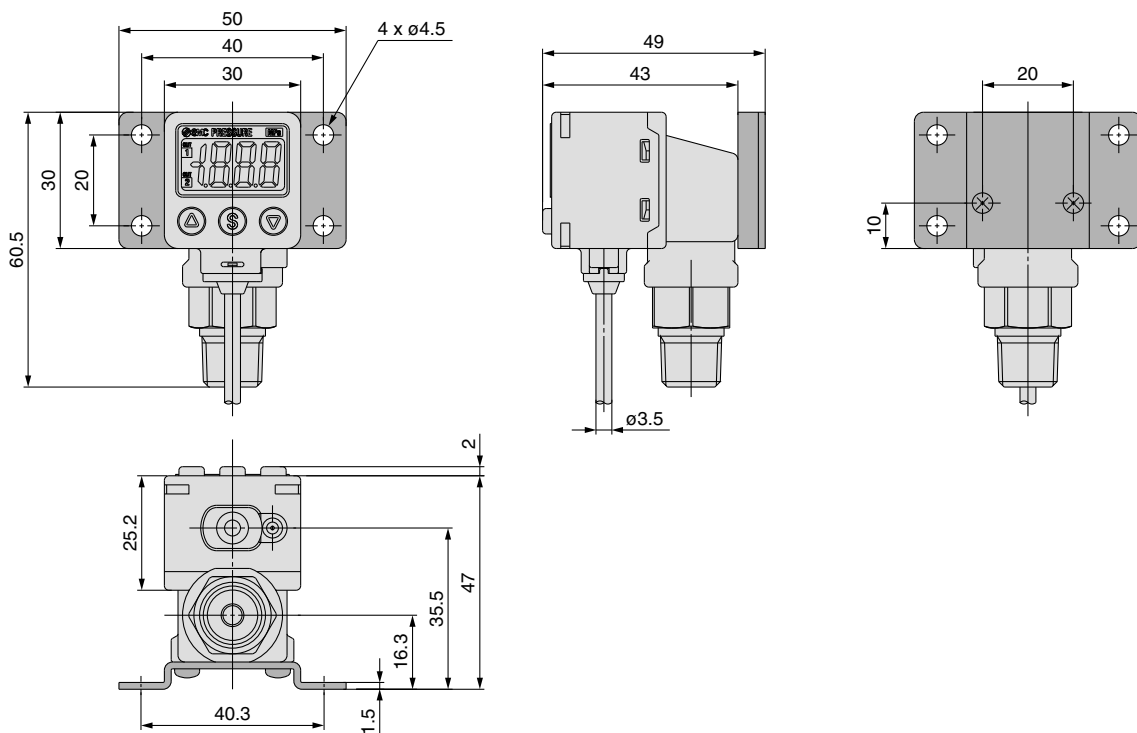

2-Color Display Digital Pressure Switch For General Fluids *Series ZSE80/ISE80*

Dimensions

Panel mount (Rear ported)

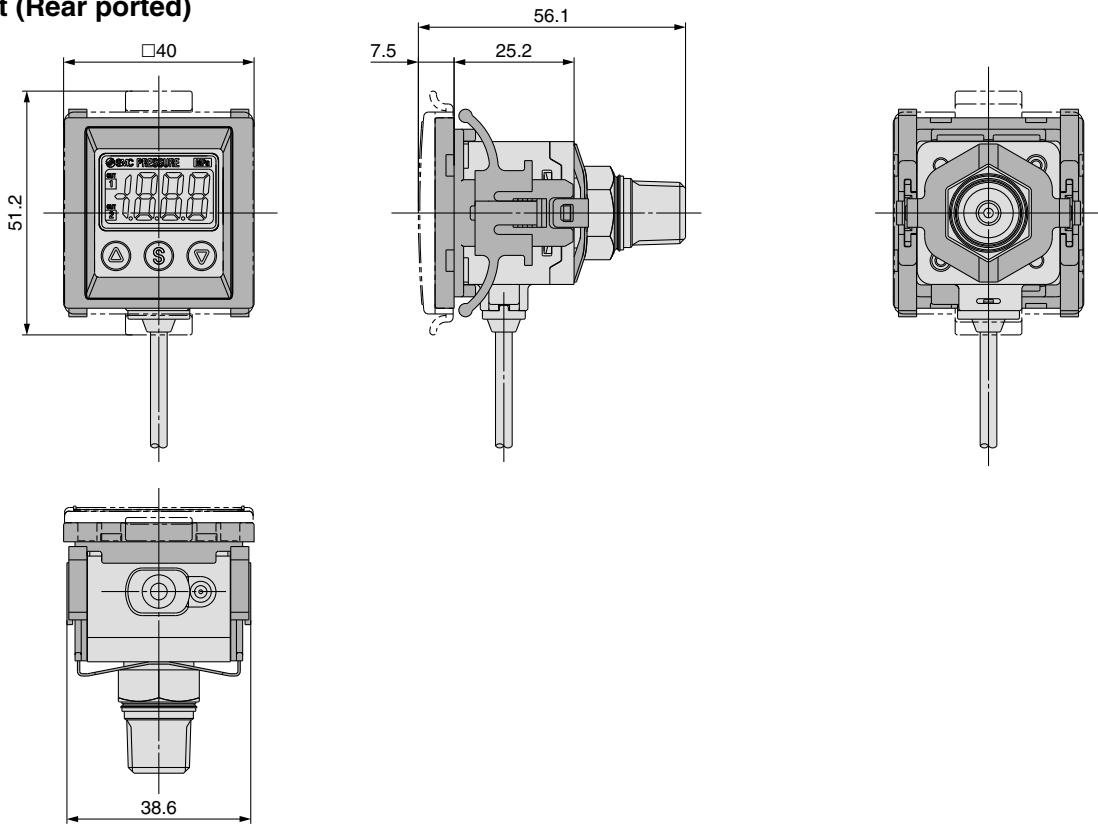

Panel-cut dimensions

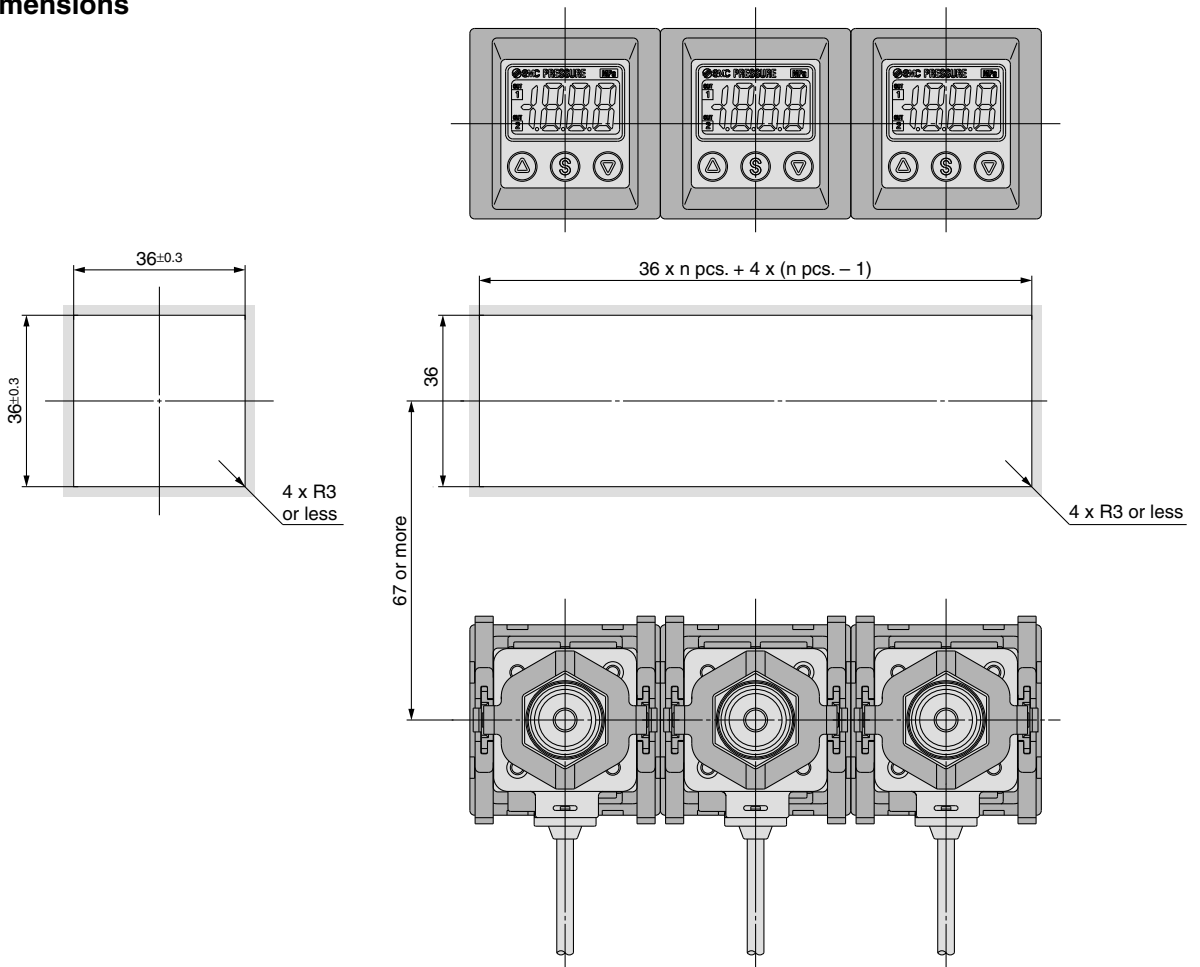

Series ZSE80/ISE80

Dimensions

Panel mount (Bottom ported)

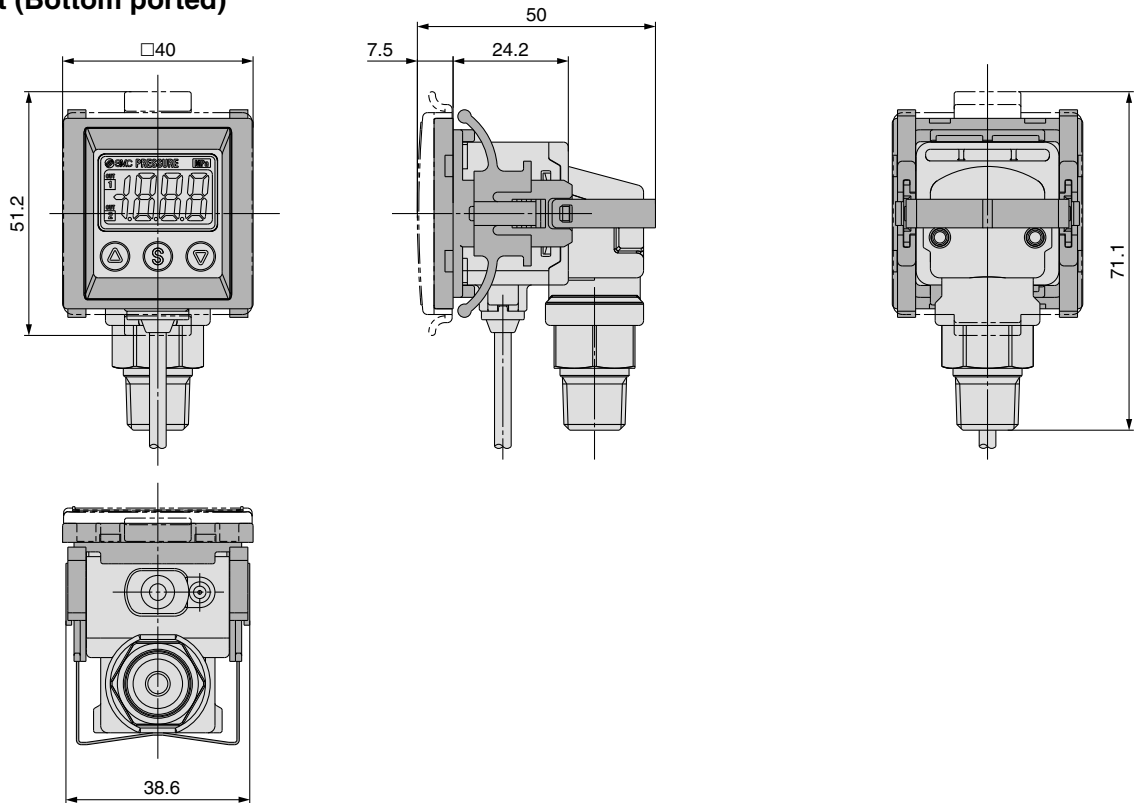

Panel-cut dimensions

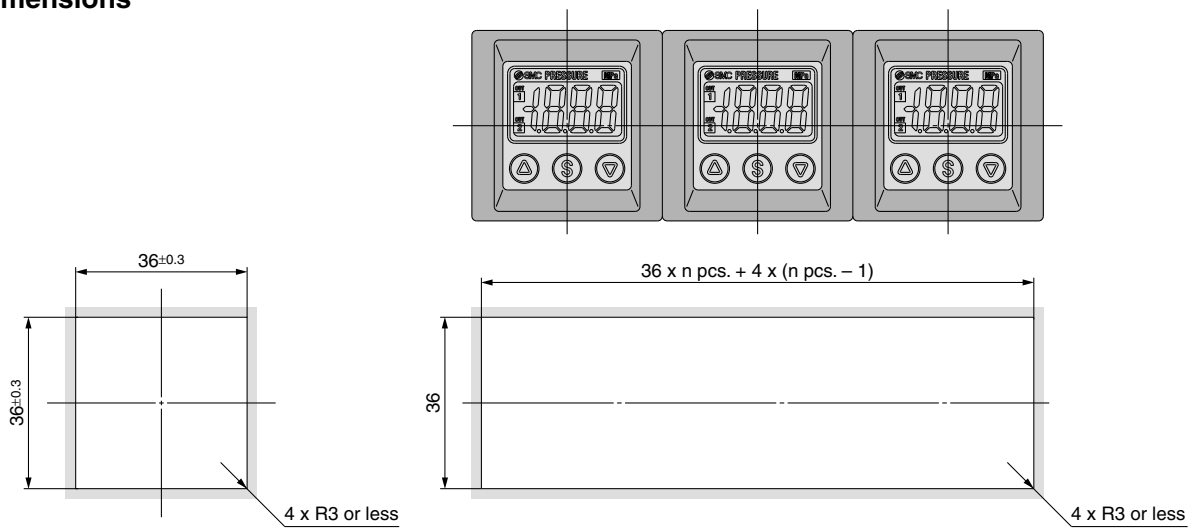

F□ in brackets stand for the function codes. Refer to the operating manual for how to operate and function codes in detail.

Function Details

A Auto-shift function (F4)

When there are large fluctuations in the supply pressure, the switch may fail to operate correctly. The auto-shift function compensates such supply pressure fluctuations. It measures the pressure at the time of auto-shift signal input and uses it as the reference pressure to correct the set-value on the switch.

Set-value correction by auto-shift function

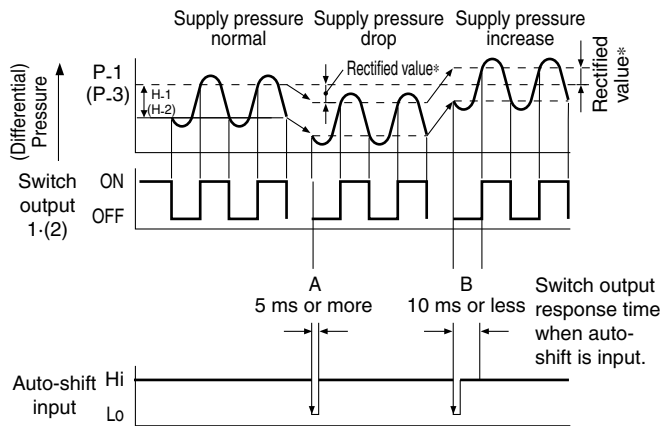

* Rectified value

When the auto-shift is selected, "ooo" will be displayed for approximately 1 second, and the pressure value at that point will be saved as a rectified value "C_5". Based on the saved rectified values, the set-value^{Note)} of "P_1", "H_1", "P_2", and "H_2" will likewise be rectified.

Note) When an output is reversed, "n_1", "H_1", "n_2", "H_2" will be rectified.

Possible Set Range for Auto-Shift Input

	Regulating pressure range	Possible set range
Compound pressure	-110.0 to 110.0 kPa	-220 to 220 kPa
Vacuum pressure	10.0 to -111.0 kPa	121.0 to -121.0 kPa
Positive pressure	-0.105 to 1.100 MPa	-1.205 to 1.205 MPa
	-0.105 to 2.20 MPa	-2.31 to 2.31 MPa

Auto-shift zero

The basic function of auto-shift zero is the same as the function for auto-shift. Also, it corrects values on the display, based on a pressure value of 0, when the auto-shift is selected.

B Auto-preset function (F8)

Auto-preset function, when selected in the initial setting, calculates and stores the set-value from the measured pressure.

The optimum set-value is determined automatically by repeating vacuum and break with the target workpiece several times.

Suction Verification

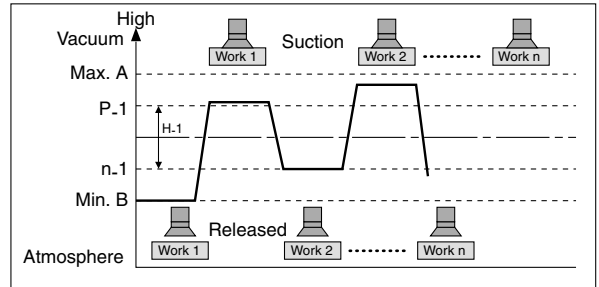

Formula for Obtaining the Set-Value

P_1 or P_2	H_1 or H_2
$P_1 (P_2) = A - (A-B)/4$	$H_1 (H_2) = (A-B)/2$
$n_1 (n_2) = B + (A-B)/4$	

C Precision indicator setting function (F7)

Fine adjustment of the indicated value can be made within the range of $\pm 5\%$ of the read value. The scattering of the indicated value can be eliminated.

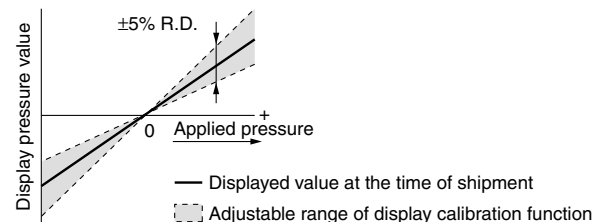

Note) When the precision indicator setting function is used, the set pressure value may change ± 1 digit.

D Peak and bottom display function

This function constantly detects and updates the maximum (minimum) value and allows to hold the maximum (minimum) pressure value.

When the (A) (B) buttons are simultaneously pressed for 1 second or longer, while "holding", the hold value will be reset.

E Key lock function

This function prevents incorrect operations such as accidentally changing the set-value.

F Zero-out function

This function clears and resets the zero value on the display of measured pressure.

For the pressure switch with analog output, the analog output shifts according to the indication. A displayed value can be adjusted within $\pm 10\%$ F.S. of the pressure when ex-factory.

Function Details

G Error indication function

Error name	Error code	Description
Overcurrent error	E _r 1	Load current of switch output (OUT1) exceeds 80 mA.
	E _r 2	Load current of switch output (OUT2) exceeds 80 mA.
Residual pressure error	E _r 3	It is still applied with pressure that is $\pm 10\%$ over the atmospheric pressure and the upper limit of the rated pressure range when it is cleared to zero. * After displaying the error code for 1 second, the switch automatically returns to the measuring mode. Due to individual product differences, the setting range varies ± 1 digits.
Applied pressure error	H _{HH}	Supply pressure exceeds the maximum set pressure.
	L _{LL}	Supply pressure is below the minimum set pressure.
Auto-shift error	OR	The value measured at the time of auto-shift input is outside the set pressure range. * After displaying the error code for one second, the switch returns to the measuring mode.
System error	E _r 0	Internal data error
	E _r 4	Internal data error
	E _r 7	Internal data error

H Anti-chattering function (F3)

A large bore cylinder or ejector consumes a large volume of air in operation and may experience a temporary drop in the supply pressure. This function prevents detection of such temporary drops in the supply pressure as an error.

Available response time settings
20 ms, 100 ms, 500 ms, 1000 ms, 2000 ms

<Principle>

This function averages pressure values measured during the response time set by the user and then compares the average pressure value with the pressure set point value to output the result on the switch.

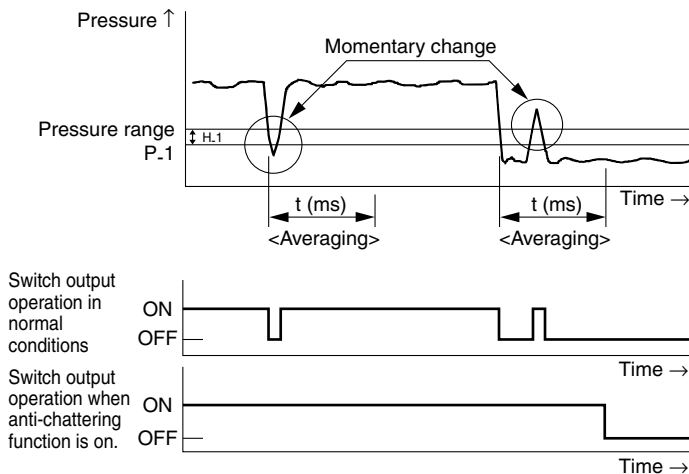

I Unit display switching function (F0)

Display units can be switched with this function.

Pressure range	Applicable pressure sensor	For compound pressure	For vacuum pressure	For positive pressure	
		ZSE80F	ZSE80	ISE80	ISE80H*
Set pressure range		-110 to 110 kPa	10 to -111 kPa	-0.1 to 1.1 MPa	-0.1 to 2.2 MPa
PR	kPa	0.1	0.1	1	1
	MPa	—	—	0.001	0.001
GF	kgf/cm ²	0.001	0.001	0.01	0.01
bAr	bar	0.001	0.001	0.01	0.01
PSI	psi	0.02	0.02	0.1	1
inH	inHg	0.1	0.1	—	—
mmH	mmHg	1	1	—	—

* ISE80H: Does not indicate the last digit when the pressure is 2.000 MPa or higher.

J Power-saving mode (F9)



The numerical value disappears and the decimal points blink.

Power-saving mode can be selected.

It shifts to the power-saving mode without button operation for 30 seconds. It is set to the normal mode (Power-saving mode is OFF.) when ex-factory. (Decimal points and operation indicator light (only when the switch output is turned ON.) blink in the power-saving mode.)

K Secret code setting (F10)



Input an arbitrary three-digit value.

* The set-value can be confirmed when the key is locked.

It can be set whether code number input is required or not when key is locked. It is set to input no code number when ex-factory.

Series ZSE80/ISE80 Made to Order

Please contact SMC for detailed dimensions, specifications, and lead times.



1 Wetted parts: Stainless steel 316L

This pressure switch has better corrosion resistance that uses stainless steel 316L for the wetted parts (pressure sensor and fitting).

How to Order



* Refer to How to Order on page 1 for standard specifications.

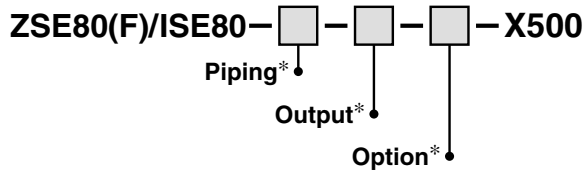

Note 1) Not applicable to the rated pressure -0.1 to 2 MPa specifications (ISE80H).
Note 2) A restrictor (equivalent to -X510) is installed inside the fitting. (Piping specifications A2(L) and B2(L) are excluded.)

2 Lead wire length 3 m

It has a lead wire extended to 3 meters.

How to Order



* Refer to How to Order on page 1 for standard specifications.

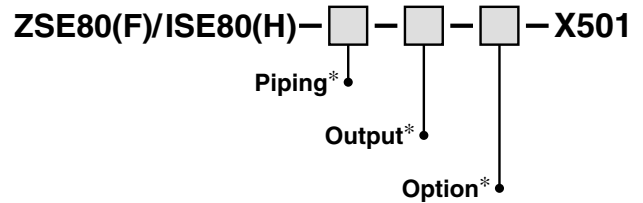

Specifications

Model	ZSE80(F)	ISE80
Withstand pressure	500 kPa	1.5 MPa
Applicable fluid	Fluids do not corrode stainless steel 316L	

Models other than above are the same specifications as standard.

3 Restrictor installed fitting

A restrictor is installed inside the fitting in order to improve endurance of water collision with rush inertia in the piping when adsorption is broken.

How to Order

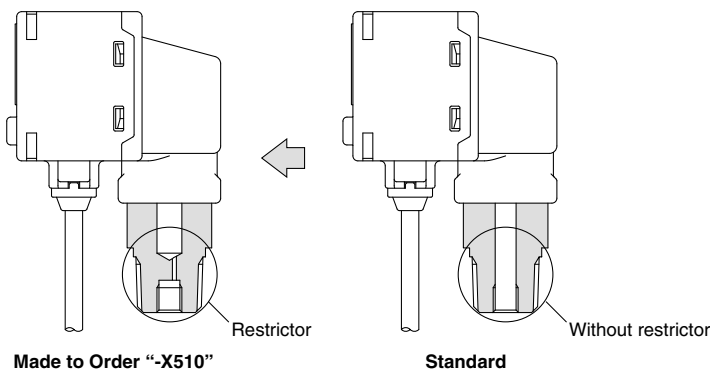
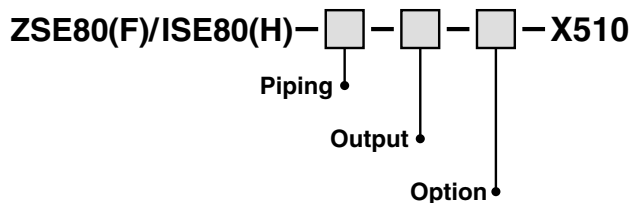

Note 1) Not applicable for piping specifications A2(L) and B2(L).
Note 2) Sometimes does not work for suppression of water hammer effect even if this product is used. Take other measures in such a case.





Series ZSE80/ISE80

Safety Instructions

These safety instructions are intended to prevent a hazardous situation and/or equipment damage. These instructions indicate the level of potential hazard by labels of "Caution", "Warning" or "Danger". To ensure safety, be sure to observe ISO 4414 ^{Note 1)}, JIS B 8370 ^{Note 2)} and other safety practices.

■ Explanation of the Labels

Labels	Explanation of the labels
 Danger	In extreme conditions, there is a possible result of serious injury or loss of life.
 Warning	Operator error could result in serious injury or loss of life.
 Caution	Operator error could result in injury ^{Note 3)} or equipment damage. ^{Note 4)}

Note 1) ISO 4414: Pneumatic fluid power – General rules relating to systems

Note 2) JIS B 8370: General Rules for Pneumatic Equipment

Note 3) Injury indicates light wounds, burns and electrical shocks that do not require hospitalization or hospital visits for long-term medical treatment.

Note 4) Equipment damage refers to extensive damage to the equipment and surrounding devices.

■ Selection/Handling/Applications

1. The compatibility of the pneumatic equipment is the responsibility of the person who designs the pneumatic system or decides its specifications.

Since the products specified here are used in various operating conditions, their compatibility for the specific pneumatic system must be based on specifications or post analysis and/or tests to meet the specific requirements. The expected performance and safety assurance are the responsibility of the person who has determined the compatibility of the system. This person should continuously review the suitability of all items specified, referring to the latest catalog information with a view to giving due consideration to any possibility of equipment failure when configuring a system.

2. Only trained personnel should operate pneumatically operated machinery and equipment.

Compressed air can be dangerous if handled incorrectly. Assembly, handling or repair of pneumatic systems should be performed by trained and experienced operators. (Understanding JIS B 8370 General Rules for Pneumatic Equipment, and other safety rules are included.)

3. Do not service machinery/equipment or attempt to remove components until safety is confirmed.

1. Inspection and maintenance of machinery/equipment should only be performed once measures to prevent falling or runaway of the driven objects have been confirmed.
2. When equipment is removed, confirm that safety process as mentioned above. Turn off the supply pressure for this equipment and exhaust all residual compressed air in the system, and release all the energy (liquid pressure, spring, condenser, gravity).
3. Before machinery/equipment is restarted, take measures to prevent quick extension of a cylinder piston rod, etc.

4. If the equipment will be used in the following conditions or environment, please contact SMC first and be sure to take all necessary safety precautions.

1. Conditions and environments beyond the given specifications, or if product is used outdoors.
2. Installation on equipment in conjunction with atomic energy, railway, air navigation, vehicles, medical equipment, food and beverages, recreation equipment, emergency stop circuits, clutch and brake circuits in press applications, or safety equipment.
3. An application which has the possibility of having negative effects on people, property, requiring special safety analysis.
4. If the products are used in an interlock circuit, prepare a double interlock style circuit with a mechanical protection function for the prevention of a breakdown. And, examine the devices periodically if they function normally or not.

■ Exemption from Liability

1. SMC, its officers and employees shall be exempted from liability for any loss or damage arising out of earthquakes or fire, action by a third person, accidents, customer error with or without intention, product misuse, and any other damages caused by abnormal operating conditions.

2. SMC, its officers and employees shall be exempted from liability for any direct or indirect loss or damage, including consequential loss or damage, loss of profits, or loss of chance, claims, demands, proceedings, costs, expenses, awards, judgments and any other liability whatsoever including legal costs and expenses, which may be suffered or incurred, whether in tort (including negligence), contract, breach of statutory duty, equity or otherwise.

3. SMC is exempted from liability for any damages caused by operations not contained in the catalogs and/or instruction manuals, and operations outside of the specification range.

4. SMC is exempted from liability for any loss or damage whatsoever caused by malfunctions of its products when combined with other devices or software.



Series ZSE80/ISE80

Specific Product Precautions 1

Be sure to read this before handling.

Refer to the back of page 1 for Safety Instructions and “Precautions for Handling Pneumatic Devices” (M-03-E3A) for Pressure Switches Precautions.

Handling

Warning

1. Do not drop, bump, or apply excessive impacts (980 m/s²) while handling. Although the body of the sensor may not be damaged, the internal parts of the sensor could be damaged and lead to a malfunction.
2. The tensile strength of the cord is 49 N. Applying a greater pulling force on it can cause a malfunction. When handling, hold the body of the sensor—do not dangle it from the cord.
3. Do not exceed the screw-in torque of 13.6 N·m when connecting the pipe to the switch. Exceeding these values may cause the switch to malfunction.
4. Do not use pressure sensors with corrosive and/or flammable gases or liquids.

Connection

Warning

1. Incorrect wiring can damage the switch and cause a malfunction or erroneous switch output.
2. Connections should be done while the power is turned off.
3. Wire separately from power lines and high voltage lines, avoiding wiring in the same conduit with these lines. Malfunctions may occur due to noise from these other lines.
4. If a commercial switching regulator is used, make sure that the F.G. terminal is grounded.

Operating Environment

Warning

1. This pressure switch is CE marked; however, it is not equipped with surge protection against lightning. Lightning surge countermeasures should be applied directly to system components as necessary.
2. This pressure switch does not have an explosion proof rating. Never use in the presence of an explosive gas as this may cause a serious explosion.

Caution

1. Do not use this product in an environment that gives oil or solvent splash over it.
2. When this pressure switch is used in a place where water and dust splash on, water and dust may enter inside the switch through the atmospheric vent port. Insert a $\varnothing 4$ tube (I.D. $\varnothing 2.5$) into the atmospheric vent port, and bring piping of the opposite side up to the safe position to keep it from water and dust. Do not bend the tubing or close the hole of it. It causes malfunction with the measurement of positive pressure.

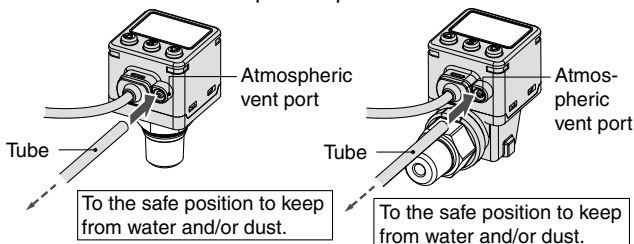

- * Make sure that the tubing is inserted to the end of the atmospheric vent port.
- * Use SMC tubing, TU0425 (Material: Polyurethane, Tubing O.D. $\varnothing 4$, I.D. $\varnothing 2.5$).

Operating Environment

Caution

3. Some fluids may generate static electricity when resin piping is used for piping. Take measures against static electricity with equipment when this switch is used in connection with resin piping. Also, the ground should be separate from that of the units that generate strong electromagnetic noise or high frequency, otherwise, the switch can be damaged by static electricity.

Pressure Source

Warning

1. **Use of poisonous and deleterious substance, corrosive or flammable gas.**

The materials used for the pressure sensor and the fitting of this switch are stainless steel 630, stainless steel 304 and stainless steel 316L (made to order). Do not use fluids such as **poisonous, deleterious substance and corrosive gas**.

The switch is not protected against explosion. Do not use it with **flammable gas**, either.

2. **Fluid compatibility**

The fluid contact areas are stainless steel 630 (pressure sensor), stainless steel 304 (fitting), stainless steel 316L (pressure sensor, fittings, made to order). Use fluid that will not corrode the materials.

(For corrosiveness of fluid, consult with the manufacturer of the fluid.)

3. **Intrusion of water and drain**

A pressure sensor of stainless steel diaphragm is used for this switch. The pressure sensor of this switch can be damaged by the rush inertia of water when the drain contained in water and air collide with the pressure sensor when vacuum is broken after vacuum adsorption is confirmed, and it may cause malfunction with the pressure indication. If there is a possibility of water or drainage getting in, narrow the diameter of the piping to the pressure switch, or make an orifice in the middle of the piping. Extra attention is needed when the rear surface piping type model is used.

4. **Withstand pressure**

When liquid fluid is used, rapid pressure change can be generated such as water hammer and surge pressure when a valve is turned ON/OFF.

Install a dumper or an absorber or an accumulator as a countermeasure according to necessity.

It may damage the pressure sensor or the switch if pressure

<Piping specifications A2(L), B2(L)>

Helium leakage test

Helium leakage test is conducted on the welding parts. Use a ferrule by Swagelok (Swagelok® fittings) as the TSJ fittings and packing, ground, etc. by Swagelok (VCR® fittings) as the URJ fittings. If a ferrule, packing or ground by other manufacturers are to be used, conduct helium leakage test before using those products.

* Swagelok® and VCR® are registered trademarks of Swagelok Company.



Series ZSE80/ISE80 Specific Product Precautions 2

Be sure to read this before handling.
Refer to the back of page 1 for Safety Instructions and “Precautions for Handling Pneumatic Devices” (M-03-E3A) for Pressure Switches Precautions.

Mounting

Caution

1. Mounting with panel mount adapter

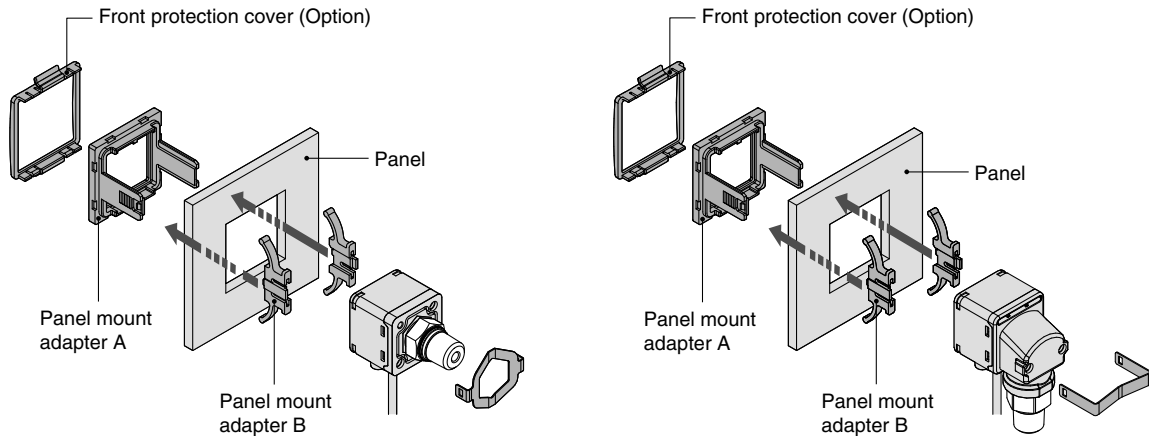

2. Mounting with brackets

Mount a bracket to the using two M3 x 5L mounting screws and install on piping. The switch can be installed horizontally depending on the installation location.

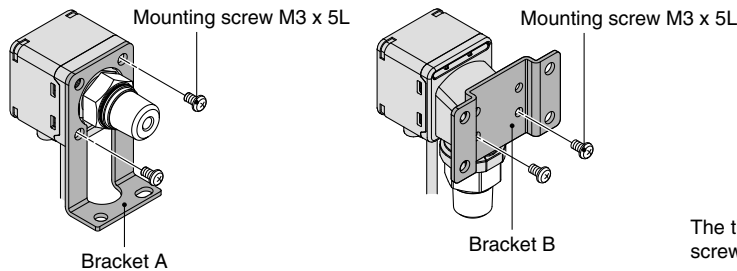

The tightening torque for bracket mounting screw should be 0.98 N·m or less.

Set Pressure Range and Rated Pressure Range

Caution

Set the pressure within the rated pressure range.

The set pressure range is the range of pressure that is possible in setting.

The rated pressure range is the range of pressure that satisfies the specifications (accuracy, linearity, etc.) on the switch.

Although it is possible to set a value outside the rated pressure range, the specifications will not be guaranteed even if the value stays within the set pressure range.

Switch	Pressure range				
	-100 kPa	0	100 kPa	1 MPa	2 MPa
For vacuum pressure					
ZSE80	-101 kPa	0			
	-111 kPa		10 kPa		
For compound pressure					
ZSE80F	-100 kPa		100 kPa		
	-110 kPa		110 kPa		
For positive pressure					
ISE80	-0.1 MPa			1 MPa	
	-0.105 MPa			1.1 MPa	
ISE80H	-0.1 MPa				2 MPa
	-0.105 MPa				2.2 MPa



SMC'S GLOBAL MANUFACTURING, DISTRIBUTION AND SERVICE NETWORK

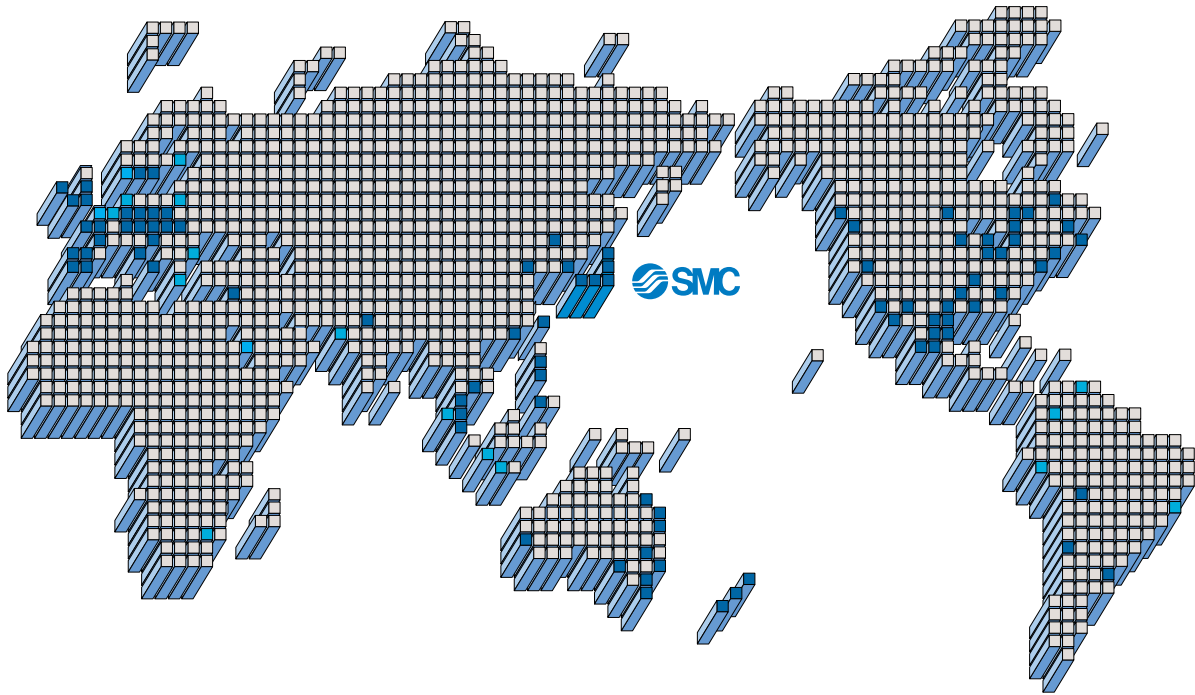

EUROPE

AUSTRIA

SMC Pneumatik GmbH (Austria)

BELGIUM

SMC Pneumatics N.V./S.A.

BULGARIA

SMC Industrial Automation Bulgaria Eood

CROATIA

SMC Industrijska Automatika d.o.o.

CZECH REPUBLIC

SMC Industrial Automation CZ s.r.o.

DENMARK

SMC Pneumatik A/S

ESTONIA

SMC Pneumatics Estonia OÜ

FINLAND

SMC Pneumatics Finland Oy

FRANCE

SMC Pneumatique SA

GERMANY

SMC Pneumatik GmbH

GREECE

SMC Hellas E.P.E.

HUNGARY

SMC Hungary Ipari Automatizálási Kft.

IRELAND

SMC Pneumatics (Ireland) Ltd.

ITALY

SMC Italia S.p.A.

LATVIA

SMC Pnuematics Latvia SIA

LITHUANIA

UAB "SMC Pneumatics"

NETHERLANDS

SMC Pneumatics B.V.

NORWAY

SMC Pneumatics Norway AS

POLAND

SMC Industrial Automation Polska Sp.z.o.o.

ROMANIA

SMC Romania S.r.l.

RUSSIA

SMC Pneumatik LLC

SLOVAKIA

SMC Priemyselná Automatizácia Spol s.r.o.

SLOVENIA

SMC Industrijska Avtomatika d.o.o.

SPAIN/PORTUGAL

SMC España S.A.

SWEDEN

SMC Pneumatics Sweden AB

SWITZERLAND

SMC Pneumatik AG

U.K.

SMC Pneumatics (U.K.) Ltd.

ASIA

CHINA

SMC (China) Co., Ltd.

HONG KONG

SMC Pneumatics (Hong Kong) Ltd.

INDIA

SMC Pneumatics (India) Pvt. Ltd.

INDONESIA

PT SMC Pneumatics Indonesia

MALAYSIA

SMC Pneumatics (S.E.A.) Sdn. Bhd.

PHILIPPINES

Shoketsu SMC Corporation

SINGAPORE

SMC Pneumatics (S.E.A.) Pte. Ltd.

SOUTH KOREA

SMC Pneumatics Korea Co., Ltd.

TAIWAN

SMC Pneumatics (Taiwan) Co., Ltd.

THAILAND

SMC (Thailand) Ltd.

NORTH AMERICA

CANADA

SMC Pneumatics (Canada) Ltd.

MEXICO

SMC Corporation (Mexico), S.A. de C.V.

U.S.A.

SMC Corporation of America

SOUTH AMERICA

ARGENTINA

SMC Argentina S.A.

BOLIVIA

SMC Pneumatics Bolivia S.r.l.

BRAZIL

SMC Pneumáticos do Brasil Ltda

CHILE

SMC Pneumatics (Chile) S.A.

VENEZUELA

SMC Neumatica Venezuela S.A.

OCEANIA

AUSTRALIA

SMC Pneumatics (Australia) Pty. Ltd.

NEW ZEALAND

SMC Pneumatics (N.Z.) Ltd.

Safety Instructions

Be sure to read "Precautions for Handling Pneumatic Devices" (M-03-E3A) before using.

SMC Corporation

Akihabara UDX 15F,
4-14-1, Sotokanda, Chiyoda-ku, Tokyo 101-0021, JAPAN
Phone: 03-5207-8249 Fax: 03-5298-5362
URL <http://www.smcworld.com>
© 2007 SMC Corporation All Rights Reserved

Specifications are subject to change without prior notice
and any obligation on the part of the manufacturer.

D-DN

1st printing LW printing LW 13500DN Printed in Japan.

This catalog is printed on recycled paper with concern for the global environment.