



ENGLISH

Datasheet

RS Pro Vernier Caliper Thumb Lock style

RS Stock No: 464-9952

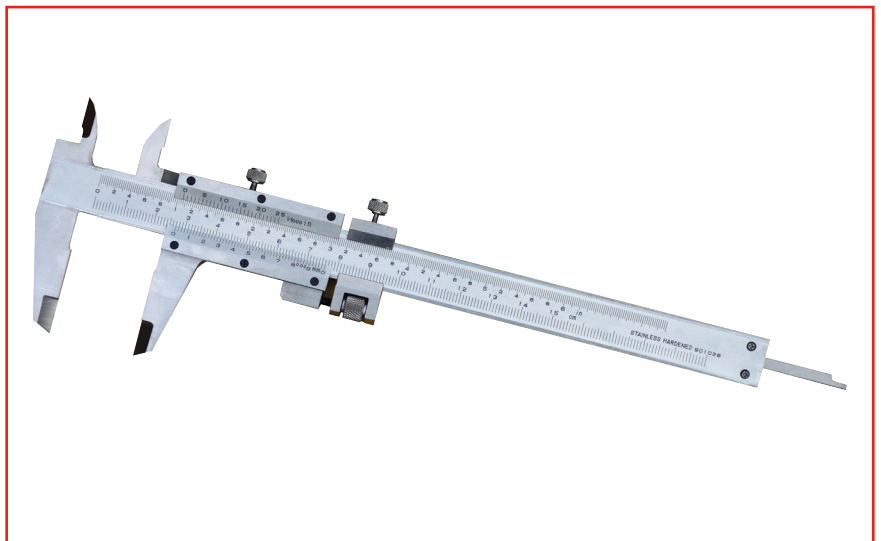

Specifications:

Hardened stainless steel body with Satin chrome finish

Thumb Lock

Depth Rod

Four-way measurement:

Raised sliding surface to prevent wear to scale

Range: 150mm/0-6"

Metric Grads: 0.02mm

Inch Grads: 0.001"

Accuracy External Jaws: $\pm 0.02\text{mm}$

Accuracy Internal Jaws & Depth Rod: $\pm 0.04\text{mm}$

External Jaw Length: 40mm

Internal Jaw Length: 18mm

Order Code	Manufacturers Code	Description
464-9952	51-120-006	Vernier Caliper Thumb Lock Style

Datasheet

RS Pro Vernier Caliper Thumb Lock style

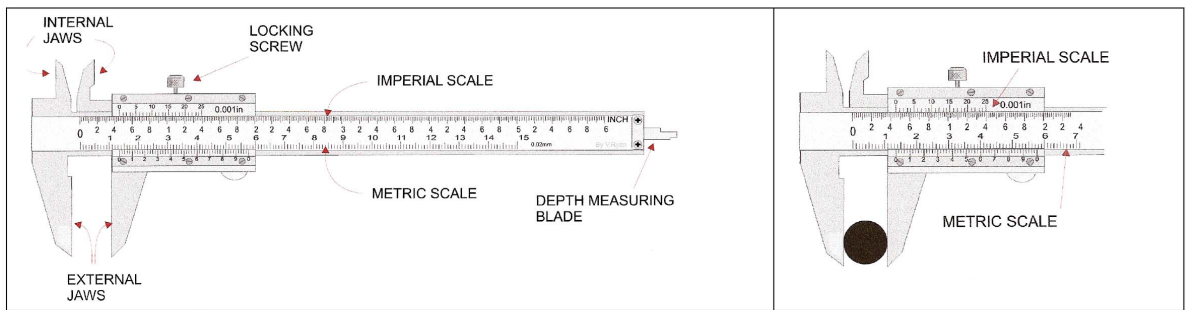
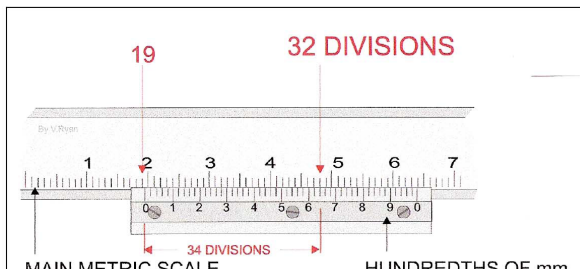
Example 1:

$$19 + 32 \times 0.02$$

$$19 + 0.64$$

$$19.64 = \text{Correct reading}$$

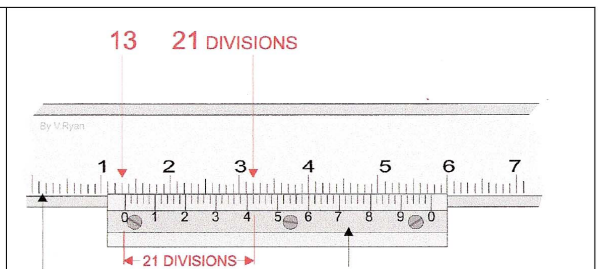
Example 2:

$$13 + 21 \times 0.02$$

$$13 + 0.42$$

$$13.42 = \text{Correct reading}$$