

TC74HC590AP, TC74HC590AF

8-Bit Binary Counter/Register with 3-State Outputs

The TC74HC590A is a high speed CMOS 8-BIT COUNTER/REGISTER fabricated with silicon gate C²MOS technology.

It achieves the high speed operation similar to equivalent LSTTL while maintaining the CMOS low power dissipation.

The internal counter counts on the positive going edge of Counter Clock (CCK) when Counter Clock Enable ($\overline{\text{CCKEN}}$) is low. When Counter Clear ($\overline{\text{CCLR}}$) is low, the internal counter is cleared asynchronously to the clock.

Data in the internal counter are loaded into the register at positive going edge of Register Clock (RCK), and the register outputs are controlled by enable input ($\overline{\text{G}}$).

All inputs are equipped with protection circuits against static discharge or transient excess voltage.

Features

- High speed: $f_{\text{max}} = 62 \text{ MHz (typ.) at } V_{\text{CC}} = 5 \text{ V}$
- Low power dissipation: $I_{\text{CC}} = 4 \mu\text{A (max) at } T_a = 25^\circ\text{C}$
- High noise immunity: $V_{\text{NIH}} = V_{\text{NIL}} = 28\% V_{\text{CC}} \text{ (min)}$
- Output drive capability: 15 LSTTL loads for QA to QH
10 LSTTL loads for $\overline{\text{RCO}}$
- Symmetrical output impedance: $|I_{\text{OH}}| = I_{\text{OL}} = 6 \text{ mA (min)}$
For QA to QH
 $|I_{\text{OH}}| = I_{\text{OL}} = 4 \text{ mA (min)}$
For $\overline{\text{RCO}}$
- Balanced propagation delays: $t_{\text{pLH}} \approx t_{\text{pHL}}$
- Wide operating voltage range: $V_{\text{CC}} \text{ (opr)} = 2 \text{ to } 6 \text{ V}$
- Pin and function compatible with 74LS590

Pin Assignment

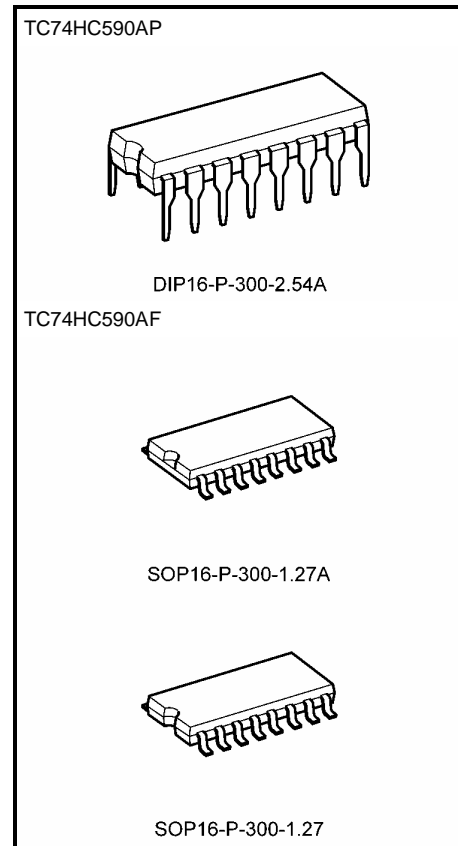
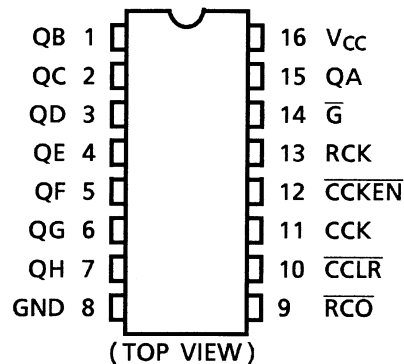

Weight	
DIP16-P-300-2.54A	: 1.00 g (typ.)
SOP16-P-300-1.27A	: 0.18 g (typ.)
SOP16-P-300-1.27	: 0.18 g (typ.)

IEC Logic Symbol

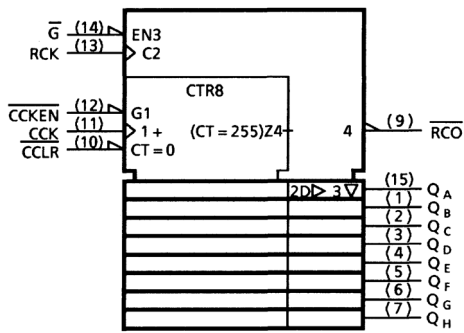

Block Diagram

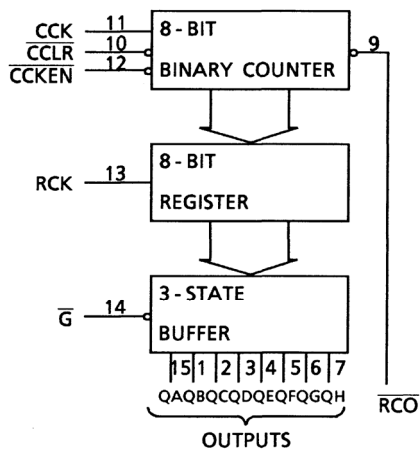

Truth Table

Inputs					Function
G	RCK	CCLR	CCKEN	CCK	
H	X	X	X	X	Q Outputs Disable
L	X	X	X	X	Q Outputs Enable
X	↑	X	X	X	Counter Data is Stored into Register
X	↓	X	X	X	Register State is not Changed
X	X	L	X	X	Counter Clear
X	X	H	L	↑	Advance One Count
X	X	H	L	↓	No Count
X	X	H	H	X	No Count

X: Don't care

$$\overline{RCO} = \overline{QA'} \cdot \overline{QB'} \cdot \overline{QC'} \cdot \overline{QD'} \cdot \overline{QE'} \cdot \overline{QF'} \cdot \overline{QG'} \cdot \overline{QH'}$$

(QA' to QH': internal outputs of the counter)

Timing Chart

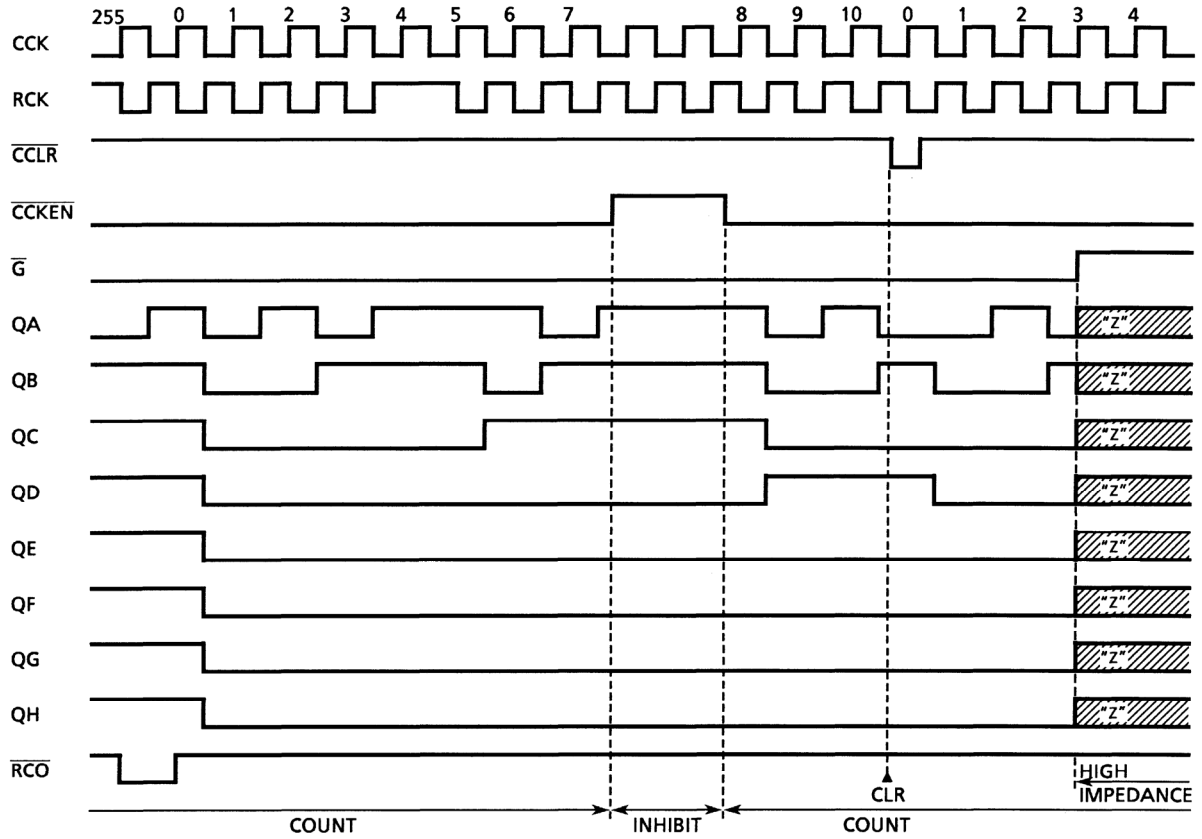

Logic Diagram

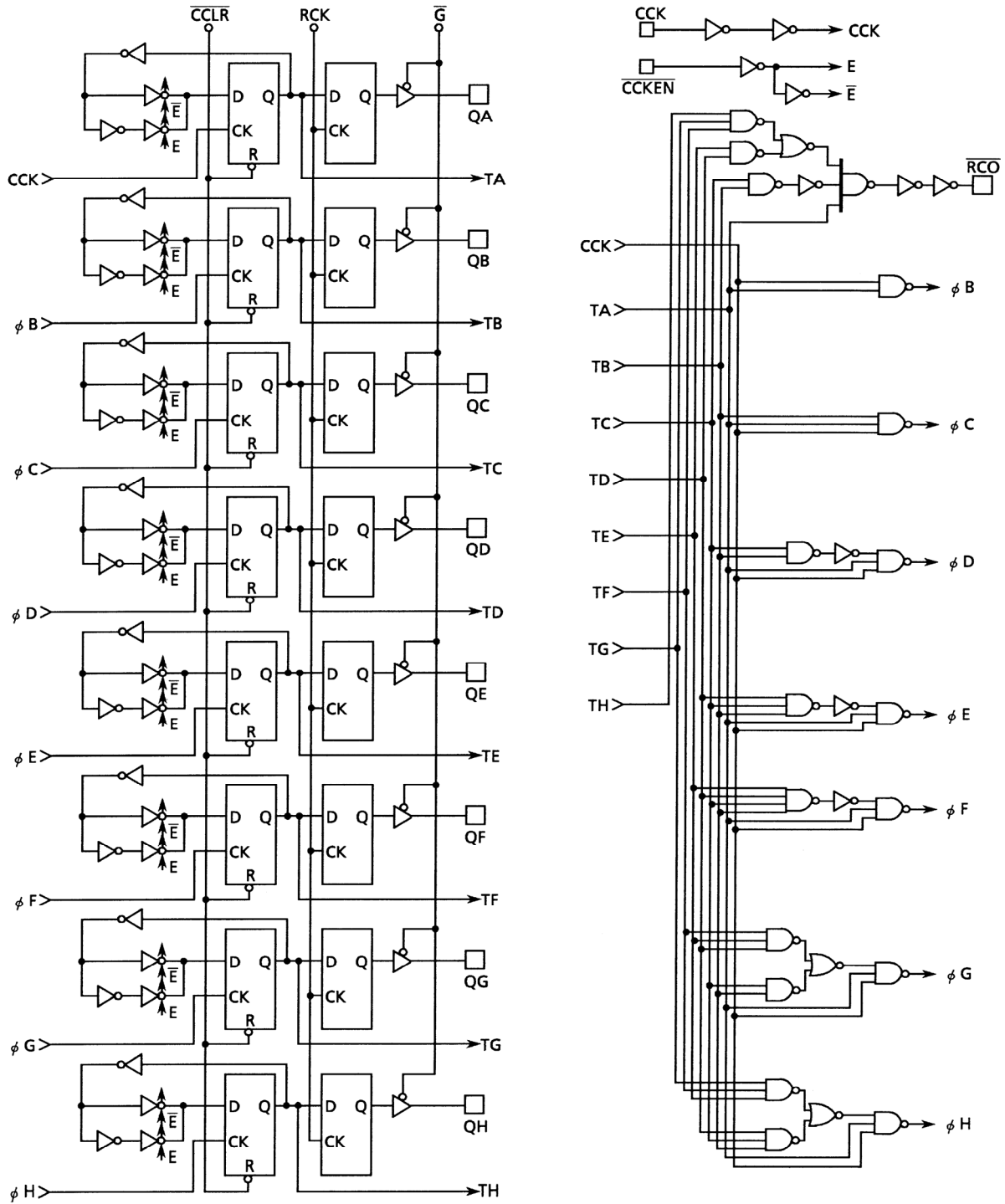

Absolute Maximum Ratings (Note 1)

Characteristics	Symbol	Rating	Unit
Supply voltage range	V_{CC}	-0.5 to 7	V
DC input voltage	V_{IN}	-0.5 to $V_{CC} + 0.5$	V
DC output voltage	V_{OUT}	-0.5 to $V_{CC} + 0.5$	V
Input diode current	I_{IK}	± 20	mA
Output diode current	I_{OK}	± 20	mA
DC output current (RCO) (QA to QH)	I_{OUT}	± 25 ± 35	mA
DC V_{CC} /ground current	I_{CC}	± 75	mA
Power dissipation	P_D	500 (DIP) (Note 2)/180 (SOP)	mW
Storage temperature	T_{stg}	-65 to 150	°C

Note 1: Exceeding any of the absolute maximum ratings, even briefly, lead to deterioration in IC performance or even destruction.

Note 2: 500 mW in the range of $T_a = -40$ to 65°C . From $T_a = 65$ to 85°C a derating factor of -10 mW/°C shall be applied until 300 mW.

Recommended Operating Conditions (Note)

Characteristics	Symbol	Rating	Unit
Supply voltage	V_{CC}	2 to 6	V
Input voltage	V_{IN}	0 to V_{CC}	V
Output voltage	V_{OUT}	0 to V_{CC}	V
Operating temperature	T_{opr}	-40 to 85	°C
Input rise and fall time	t_r, t_f	0 to 1000 ($V_{CC} = 2.0$ V) 0 to 500 ($V_{CC} = 4.5$ V) 0 to 400 ($V_{CC} = 6.0$ V)	ns

Note: The recommended operating conditions are required to ensure the normal operation of the device. Unused inputs must be tied to either VCC or GND.

Electrical Characteristics

DC Characteristics

Characteristics	Symbol	Test Condition		Ta = 25°C			Ta = -40 to 85°C		Unit		
				V _{CC} (V)	Min	Typ.	Max	Min		Max	
High-level input voltage	V _{IH}	—		2.0	1.50	—	—	1.50	—	V	
				4.5	3.15	—	—	3.15	—		
				6.0	4.20	—	—	4.20	—		
Low-level input voltage	V _{IL}	—		2.0	—	—	0.50	—	0.50	V	
				4.5	—	—	1.35	—	1.35		
				6.0	—	—	1.80	—	1.80		
High-level output voltage	V _{OH}	V _{IN} = V _{IH} or V _{IL}	I _{OH} = -20 μA	2.0	1.9	2.0	—	1.9	—	V	
				4.5	4.4	4.5	—	4.4	—		
				6.0	5.9	6.0	—	5.9	—		
			RCO	I _{OH} = -4 mA	4.5	4.18	4.31	—	4.13		—
				I _{OH} = -5.2 mA	6.0	5.68	5.80	—	5.63		—
				QA to QH	I _{OH} = -6 mA	4.5	4.18	4.31	—		4.13
I _{OH} = -7.8 mA	6.0	5.68	5.80		—	5.63	—				
Low-level output voltage	V _{OL}	V _{IN} = V _{IH} or V _{IL}	I _{OL} = 20 μA	2.0	—	0.0	0.1	—	0.1	V	
				4.5	—	0.0	0.1	—	0.1		
				6.0	—	0.0	0.1	—	0.1		
			RCO	I _{OL} = 4 mA	4.5	—	0.17	0.26	—		0.33
				I _{OL} = 5.2 mA	6.0	—	0.18	0.26	—		0.33
				QA to QH	I _{OL} = 6 mA	4.5	—	0.17	0.26		—
I _{OL} = 7.8 mA	6.0	—	0.18		0.26	—	0.33				
3-state output off-state current	I _{OZ}	V _{IN} = V _{IH} or V _{IL} V _{OUT} = V _{CC} or GND		6.0	—	—	±0.5	—	±5.0	μA	
Input leakage current	I _{IN}	V _{IN} = V _{CC} or GND		6.0	—	—	±0.1	—	±1.0	μA	
Quiescent supply current	I _{CC}	V _{IN} = V _{CC} or GND		6.0	—	—	4.0	—	40.0	μA	

Timing Requirements (input: $t_r = t_f = 6 \text{ ns}$)

Characteristics	Symbol	Test Condition	Ta = 25°C		Ta = -40 to 85°C		Unit
			V _{CC} (V)	Typ.	Limit	Limit	
Minimum pulse width (CCK, RCK)	t_W (H) t_W (L)	—	2.0	—	75	95	ns
			4.5	—	15	19	
			6.0	—	13	16	
Minimum pulse width ($\overline{\text{CCLR}}$)	t_W (L)	—	2.0	—	75	95	ns
			4.5	—	15	19	
			6.0	—	13	16	
Minimum set-up time ($\overline{\text{CCKEN}}$ -CCK)	t_s	—	2.0	—	100	125	ns
			4.5	—	20	25	
			6.0	—	17	21	
Minimum set-up time (CCK-RCK)	t_s	—	2.0	—	200	250	ns
			4.5	—	40	50	
			6.0	—	34	43	
Minimum hold time	t_h	—	2.0	—	0	0	ns
			4.5	—	0	0	
			6.0	—	0	0	
Minimum removal time ($\overline{\text{CCLR}}$)	t_{rem}	—	2.0	—	75	95	ns
			4.5	—	15	19	
			6.0	—	13	16	
Clock frequency	f	—	2.0	—	6	5	MHz
			4.5	—	33	26	
			6.0	—	39	31	

AC Characteristics ($C_L = 15 \text{ pF}$, $V_{CC} = 5 \text{ V}$, $T_a = 25^\circ\text{C}$, input: $t_r = t_f = 6 \text{ ns}$)

Characteristics	Symbol	Test Condition	Min	Typ.	Max	Unit
Output transition time ($\overline{\text{RCO}}$)	t_{TLH}	—	—	4	8	ns
	t_{THL}					
Propagation delay time (CCK- $\overline{\text{RCO}}$)	t_{pLH}	—	—	18	28	ns
	t_{pHL}					
Propagation delay time ($\overline{\text{CCLR}}$ - $\overline{\text{RCO}}$)	t_{pLH}	—	—	20	30	ns
Maximum clock frequency	f_{max}	—	32	62	—	MHz

AC Characteristics (input: $t_r = t_f = 6 \text{ ns}$)

Characteristics	Symbol	Test Condition	Ta = 25°C			Ta = -40 to 85°C		Unit		
			CL (pF)	V _{CC} (V)	Min	Typ.	Max		Min	Max
Output transition time (Qn)	t_{TLH} t_{THL}	—	50	2.0	—	25	60	—	75	ns
				4.5	—	7	12	—	15	
				6.0	—	6	10	—	13	
Output transition time ($\overline{\text{RCO}}$)	t_{TLH} t_{THL}	—	50	2.0	—	30	75	—	95	ns
				4.5	—	8	15	—	19	
				6.0	—	7	13	—	16	
Propagation delay time (CCK- $\overline{\text{RCO}}$)	t_{pLH} t_{pHL}	—	50	2.0	—	75	163	—	205	ns
				4.5	—	22	33	—	41	
				6.0	—	17	28	—	35	
Propagation delay time ($\overline{\text{CCLR}}$ - $\overline{\text{RCO}}$)	t_{pLH}	—	50	2.0	—	78	175	—	220	ns
				4.5	—	23	35	—	44	
				6.0	—	18	30	—	37	
Propagation delay time (RCK-Qn)	t_{pLH} t_{pHL}	—	50	2.0	—	62	145	—	180	ns
				4.5	—	19	29	—	36	
				6.0	—	15	25	—	31	
			150	2.0	—	78	185	—	230	
				4.5	—	24	37	—	46	
				6.0	—	19	31	—	39	
Output enable time	t_{pZL} t_{pZH}	$R_L = 1 \text{ k}\Omega$	50	2.0	—	43	105	—	130	ns
				4.5	—	14	21	—	26	
				6.0	—	12	18	—	22	
			150	2.0	—	58	150	—	190	
				4.5	—	19	30	—	38	
				6.0	—	16	26	—	33	
Output disable time	t_{pLZ} t_{pHZ}	$R_L = 1 \text{ k}\Omega$	50	2.0	—	33	105	—	130	ns
				4.5	—	16	21	—	26	
				6.0	—	12	18	—	22	
Maximum clock frequency	f_{max}	—	50	2.0	6	12	—	5	—	MHz
				4.5	30	51	—	24	—	
				6.0	35	80	—	28	—	
Input capacitance	C_{IN}	—	—	—	—	5	10	—	10	pF
Power dissipation capacitance (Note)	C_{PD}	—	—	—	—	34	—	—	—	pF

Note: C_{PD} is defined as the value of the internal equivalent capacitance which is calculated from the operating current consumption without load.

Average operating current can be obtained by the equation:

$$I_{\text{CC}} (\text{opf}) = C_{\text{PD}} \cdot V_{\text{CC}} \cdot f_{\text{IN}} + I_{\text{CC}}$$

Package Dimensions

DIP16-P-300-2.54A

Unit : mm

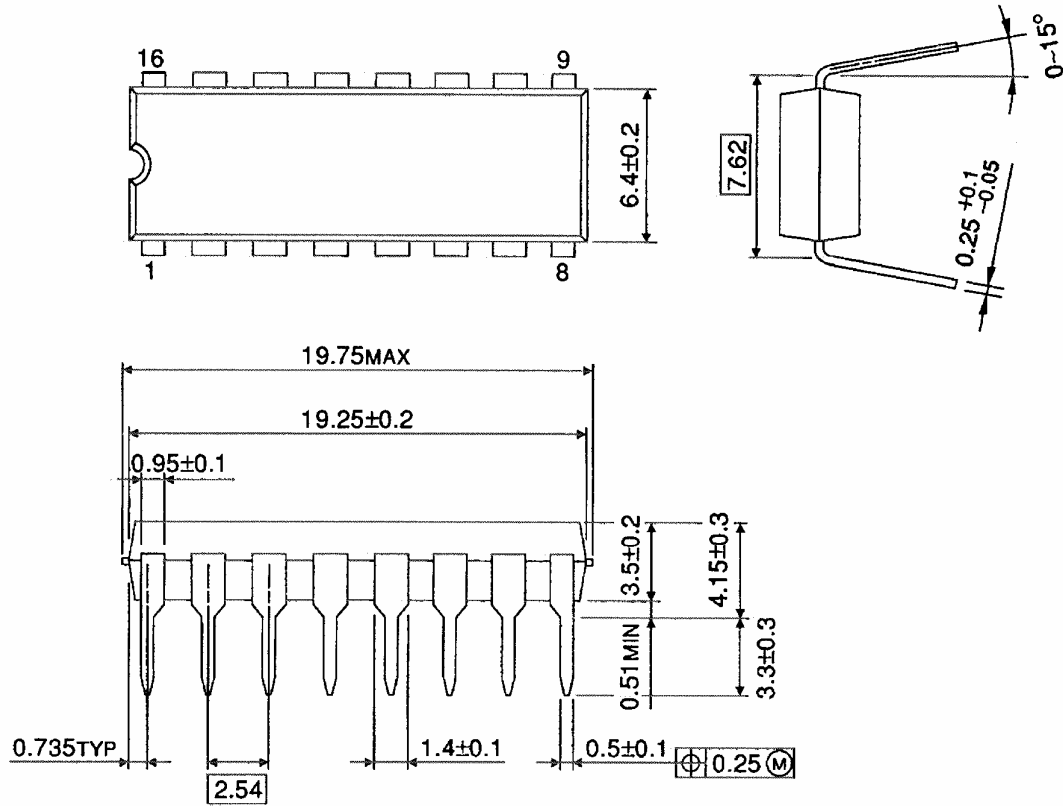

Weight: 1.00 g (typ.)

Package Dimensions

SOP16-P-300-1.27A

Unit: mm

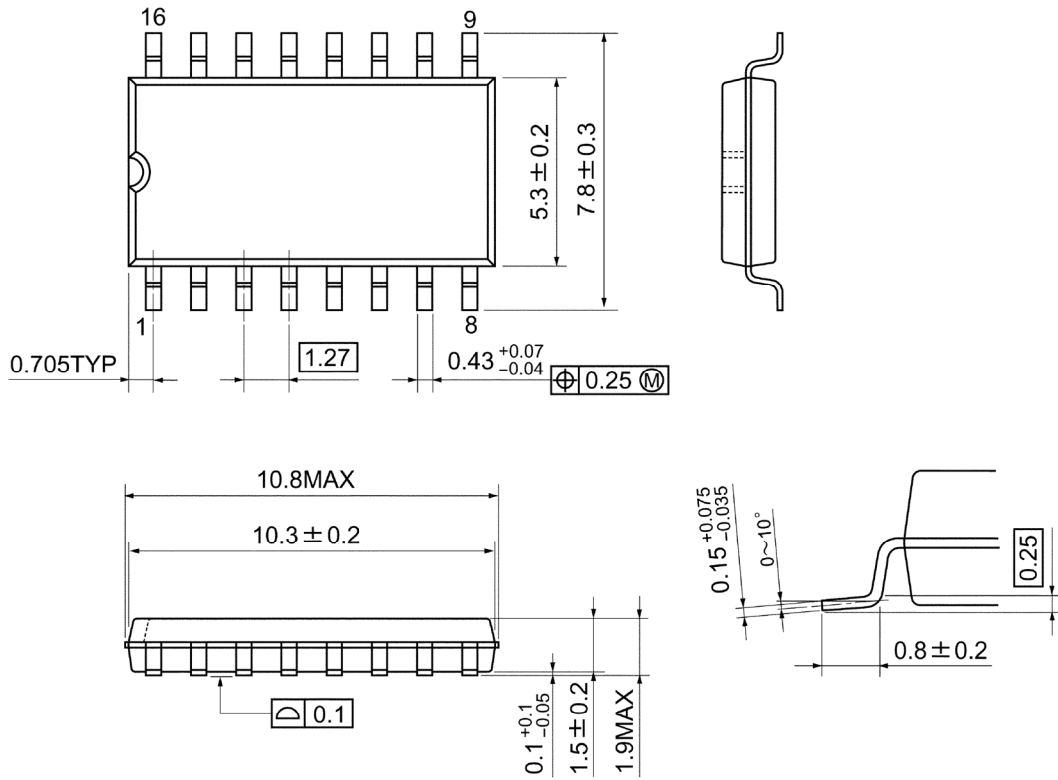

Weight: 0.18 g (typ.)

Package Dimensions

SOP16-P-300-1.27

Unit : mm

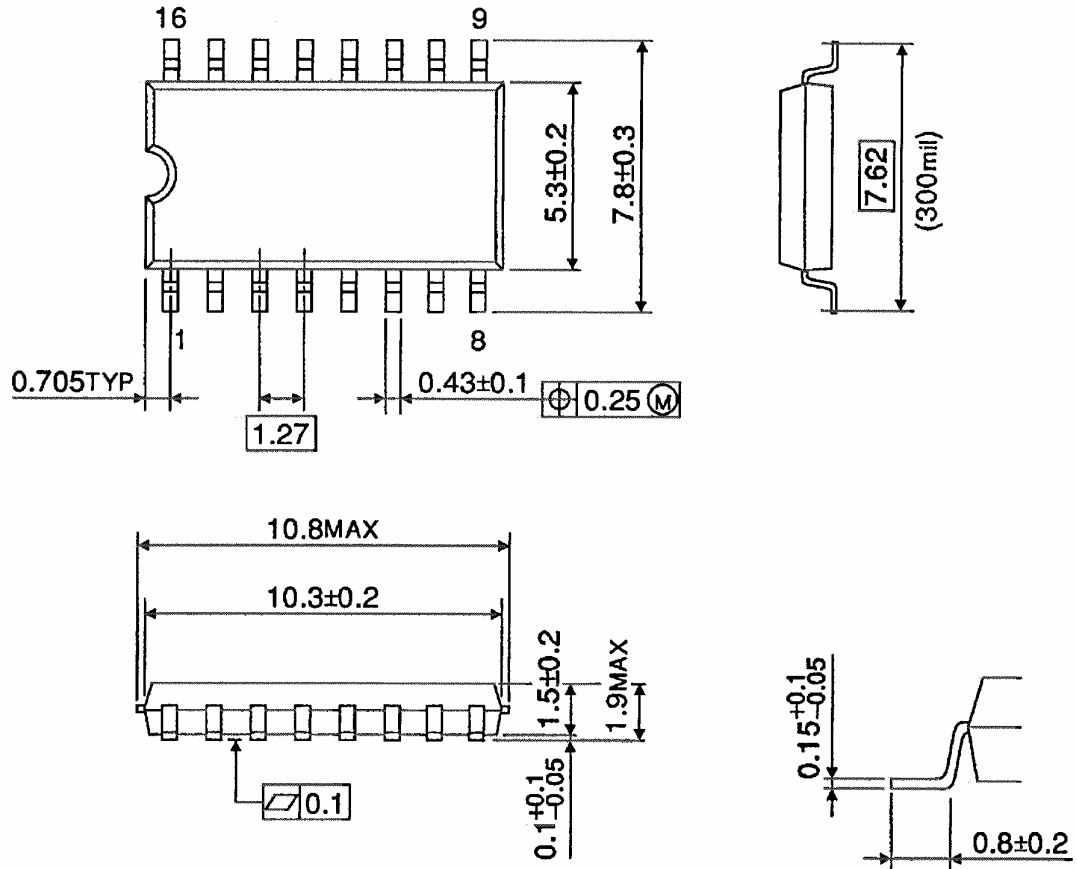

Weight: 0.18 g (typ.)

Note: Lead (Pb)-Free Packages**DIP16-P-300-2.54A SOP16-P-300-1.27A****RESTRICTIONS ON PRODUCT USE**

060116EBA

- The information contained herein is subject to change without notice. 021023_D
- TOSHIBA is continually working to improve the quality and reliability of its products. Nevertheless, semiconductor devices in general can malfunction or fail due to their inherent electrical sensitivity and vulnerability to physical stress. It is the responsibility of the buyer, when utilizing TOSHIBA products, to comply with the standards of safety in making a safe design for the entire system, and to avoid situations in which a malfunction or failure of such TOSHIBA products could cause loss of human life, bodily injury or damage to property.
In developing your designs, please ensure that TOSHIBA products are used within specified operating ranges as set forth in the most recent TOSHIBA products specifications. Also, please keep in mind the precautions and conditions set forth in the "Handling Guide for Semiconductor Devices," or "TOSHIBA Semiconductor Reliability Handbook" etc. 021023_A
- The TOSHIBA products listed in this document are intended for usage in general electronics applications (computer, personal equipment, office equipment, measuring equipment, industrial robotics, domestic appliances, etc.). These TOSHIBA products are neither intended nor warranted for usage in equipment that requires extraordinarily high quality and/or reliability or a malfunction or failure of which may cause loss of human life or bodily injury ("Unintended Usage"). Unintended Usage include atomic energy control instruments, airplane or spaceship instruments, transportation instruments, traffic signal instruments, combustion control instruments, medical instruments, all types of safety devices, etc. Unintended Usage of TOSHIBA products listed in this document shall be made at the customer's own risk. 021023_B
- The products described in this document shall not be used or embedded to any downstream products of which manufacture, use and/or sale are prohibited under any applicable laws and regulations. 060106_Q
- The information contained herein is presented only as a guide for the applications of our products. No responsibility is assumed by TOSHIBA for any infringements of patents or other rights of the third parties which may result from its use. No license is granted by implication or otherwise under any patent or patent rights of TOSHIBA or others. 021023_C
- The products described in this document are subject to the foreign exchange and foreign trade laws. 021023_E