

WE CATCH THE  
BEST TECH. FOREVER

# EVERBOUQUET INTERNATIONAL CO., LTD.

Available from Midas Components LTD  
Telephone Number: +44(0) 1493 602602  
Website: www.midascomponents.co.uk  
Email: sales@midascomponents.co.uk

PART NO. : MG1903A-SERIES

FOR MESSRS. : \_\_\_\_\_

## CONTENTS

<i>NO.</i>	<i>ITEM</i>	<i>PAGE</i>
1.	COVER	1
2.	RECORD OF REVISION	2
3.	GENERAL SPECIFICATION	3
4.	MECHANICAL DATA	4
5.	ABSOLUTE MAXIMUM RATINGS	5
6.	ELECTRICAL CHARACTERISTICS	6
7.	OPTICAL CHARACTERISTICS	7
8.	OUTLINE DIMENSION	8,9
9.	BLOCK DIAGRAM	10
10.	POWER SUPPLY FOR LCM	10



ACCEPTED BY : \_\_\_\_\_

PROPOSED BY : \_\_\_\_\_

**RECORD OF REVISION**

<b>DATE</b>	<b>PAGE</b>	<b>SUMMARY</b>

### 3. General specifications

#### 3.1 General specifications

PLEASE REFER TO :

- a. "CUSTOMER ACCEPTANCE STANDARD SPECIFICATIONS (MS-10-10000)"
- b. "CUSTOMER ACCEPTANCE STANDARD SPECIFICATIONS (IC-ST7920)"

#### 3.2 This individual specification is prior to general specifications

#### 3.3 NUMBERING SYSTEM

MG1903A 

W
---

 - 

S	Y	M	L	W	U	N
---	---	---	---	---	---	---

(1)                      (2)   (3)   (4)   (5)   (6)   (7)   (8)

(1).LCM TEMPERATURE :

"nil" : NORMAL TEMP

"W" : WIDE TEMP

(2).LCD TYPE :

"S" : STN TYPE

"F" : FSTN TYPE

(3).LCD COLOR :

"Y" : YELLOW-GREEN    "B" : BLUE(STN/NEGATIVE)/BLACK(FSTN/NEGATIVE)

"G" : GRAY                      "W" : WHITE(FSTN/POSITIVE)

(4).LCD POLARIZE TYPE :

"nil" : TRANSFLECTIVE

"M" : TRANSMISSIVE

(5).BACKLIGHT TYPE :

"R" : REFLECTIVE

"L" : LED BACKLIGHT

(6).BACKLIGHT COLOR :

LED TYPE :

"nil" : YELLOW-GREEN    "A" : AMBER

"O" : ORANGE                      "R" : RED

(7). VIEWING DIRECTION :

"nil" : 6 O'CLOCK

"3" : 3 O'CLOCK

"U" : 12 O'CLOCK

"9" : 9 O'CLOCK

(8).BACKLIGHT TYPE :

"nil" : A(+),K(-)---NORMAL

"N" : A(+),K(-)---CHANGE

#### ***4. Mechanical data***

- (1) NUMBER OF DOT -----192 W \* 32 H DOTS
- (2) MODULE SIZE -----116.0 W \* 37.0 H \* “C” T (Max) mm
- (3) EFFECTIVE AREA -----84.0 W \* 19.0 H mm
- (4) ACTIVE AREA -----80.61 W \* 15.97 H mm
- (5) DOT SIZE-----0.39 W \* 0.47 H mm
- (6) DOT PITCH -----0.42 W \* 0.50 H mm

*NOTE : The dimension of "C" , please refer to Outline dimension on PAGE 8/10*

## 5. Absolute maximum ratings

### 5.1 Electrical absolute maximum ratings

<i>I T E M</i>	<i>SYMBOL</i>	<i>MIN.</i>	<i>MAX.</i>	<i>UNIT</i>	<i>COMMENT</i>
POWER SUPPLY FOR LOGIC	V <sub>DD</sub> -V <sub>SS</sub>	-0.3	5.5	V	-----
POWER SUPPLY FOR LCD	V <sub>O</sub>	-0.3	3.5	V	-----
INPUT VOLTAGE	V <sub>I</sub>	-0.3	V <sub>DD</sub> +0.3	V	-----
STATIC ELECTRICITY	-----	-----	100	V	NOTE(1)
POWER SUPPLY FOR LED	V <sub>LED</sub>	-----	6.0	V	-----

NOTE (1): ELECTRO-STATIC DISCHARGE RESISTANCE IS TESTED BY CHARGING A 200pF CAPACITOR AND DISCHARGING IT BY CONTACT WITH A INTERFACE CONNECTOR PIN.

### 5.2 Environmental absolute maximum ratings

<i>I T E M</i>	<i>CONDITION</i>	<i>OPERATING</i>		<i>STORAGE</i>		<i>COMMENT</i>
		<i>MIN.</i>	<i>MAX.</i>	<i>MIN.</i>	<i>MAX.</i>	
AMBIENT TEMPERATURE	NORMAL	0	50	-20	70	-----
	WIDE	-20	70			
HUMIDITY	-----	NOTE (3)		NOTE (3)		NO CONDENSATION
VIBRATION NOTE (4)	-----	-----	0.5G	-----	2G	10~300Hz XYZ DIRECTIONS 1 Hr EACH
SHOCK NOTE (4)	-----	-----	3G	-----	50G	10 msec XYZ DIRECTIONS 1 TIME EACH
CORROSIVE GAS	-----	NOT ACCEPTABLE		NOT ACCEPTABLE		-----

NOTE (3):Ta 50 : 90% RH MAX.

Ta > 50 : ABSOLUTE HUMIDITY MUST BE LOWER THAN THE HUMIDITY OF 90% RH AT 50 . (80% RH AT 60 )

NOTE (4):1G = 9.8 m/s<sup>2</sup>

## 6. Electrical characteristics

Ta = 25

<i>I T E M</i>	<i>SYMBOL</i>	<i>CONDITION</i>	<i>MIN.</i>	<i>TYP.</i>	<i>MAX.</i>	<i>UNIT</i>	
POWER SUPPLY VOLTAGE FOR CIRCUIT	V <sub>DD</sub> - V <sub>SS</sub>	-----	2.7	-----	5.5	V	
INPUT VOLTAGE	V <sub>IH</sub>	-----	0.7 V <sub>DD</sub>	-----	V <sub>DD</sub>	V	
	V <sub>IL</sub>	-----	-0.3	-----	0.6	V	
OUTPUT VOLTAGE	V <sub>OH</sub>	I <sub>OH</sub> = -0.1 mA	0.8V <sub>DD</sub>	-----	V <sub>DD</sub>	V	
	V <sub>OL</sub>	I <sub>OL</sub> = 0.1 mA	-----	-----	0.1	V	
POWER SUPPLY CURRENT	I <sub>DD</sub>	V <sub>DD</sub> - V <sub>SS</sub>	-----	0.5	1.0	mA	
RECOMMENDED LCD DRIVING VOLTAGE, NOTE(1)	V <sub>O</sub> -V <sub>SS</sub>	STN/ FSTN DUTY =1/32 =10° NOTE(2)	Ta= -20°C	-----	-----	3.5	V
			Ta= 0°C	-----	-----	3.5	V
			Ta= 25°C	-----	3.0	3.5	V
			Ta= 50°C	-----	-----	3.5	V
			Ta= 70°C	-----	-----	3.5	V
POWER SUPPLY CURRENT FOR NOTE(3)	I <sub>LED</sub>	V <sub>LED</sub> =NOTE(3)	-----	NOTE(3)	NOTE(3)	mA	

NOTE (1): RECOMMENDED LCD DRIVING VOLTAGE MAY FLUCTUATE ABOUT ±0.5V BY EACH MODULE.

- (2): = 0° : VIEWING DIRECTION AT 6 O'CLOCK  
 = 180° : VIEWING DIRECTION AT 12 O'CLOCK

(3): LED CURRENT OF DIFFERENT LED TYPE

<i>LED B.L TYPE</i>	<i>V<sub>LED</sub></i>	<i>I<sub>LED</sub></i>				<i>LED COLOR</i>
		<i>MIN.</i>	<i>TYP.</i>	<i>MAX.</i>	<i>UNIT.</i>	
A	5.0V	-----	125	250	mA	YELLOW-GREEN, AMBER, ORANGE, RED

## 7. Optical characteristics

### STN TYPE LCD

Ta = 25

<i>I T E M</i>	<i>SYMBOL</i>	<i>CONDITION</i>	<i>MIN.</i>	<i>TYP.</i>	<i>MAX.</i>	<i>UNIT</i>	<i>NOTE</i>
VIEWING ANGLE	2- 1	K = 2.0 NOTE(1)	30	40	----	deg.	NOTE(2)
CONTRAST RATIO	K	= 10° NOTE(1)	3.0	4.0	----	----	NOTE(2)
RESPONSE TIME	tr (rise)	= 10° NOTE(1)	----	200	350	ms	NOTE(2)
	tf (fall)	= 10° NOTE(1)	----	300	400	ms	NOTE(2)

### FSTN /STN BLUE TYPE LCD

Ta = 25

<i>I T E M</i>	<i>SYMBOL</i>	<i>CONDITION</i>	<i>MIN.</i>	<i>TYP.</i>	<i>MAX.</i>	<i>UNIT</i>	<i>NOTE</i>
VIEWING ANGLE	2- 1	K = 2.0 NOTE(1)	30	40	----	deg.	NOTE(2)
CONTRAST RATIO	K	= 10° NOTE(1)	4.0	5.0	----	----	NOTE(2)
RESPONSE TIME	tr (rise)	= 10° NOTE(1)	----	200	350	ms	NOTE(2)
	tf (fall)	= 10° NOTE(1)	----	300	400	ms	NOTE(2)

### Brightness for LCM backlight

<i>SYMBOL</i>	<i>CONDITION</i>	<i>MIN.</i>	<i>TYP.</i>	<i>MAX.</i>	<i>UNIT</i>	<i>LED TYPE</i>	<i>NOTE</i>
B	= 0° = 0°	4.0	----	----	cd/m <sup>2</sup>	YELLOW-GREEN, RED, AMBER, ORANGE	NOTE(2) NOTE(3)

NOTE (1): = 0° WHEN VIEWING DIRECTION AT 6 O'CLOCK  
= 180° WHEN VIEWING DIRECTION AT 12 O'CLOCK

(2): SEE CUSTOMER ACCEPTANCE STANDARD SPECIFICATION FOR DEFINITION OF OPTICAL CHARACTERISTICS.

(3): UNDER NORMAL TEMPERATURE AND HUMIDITY IN A DARK ROOM.

### 8. Outline dimension

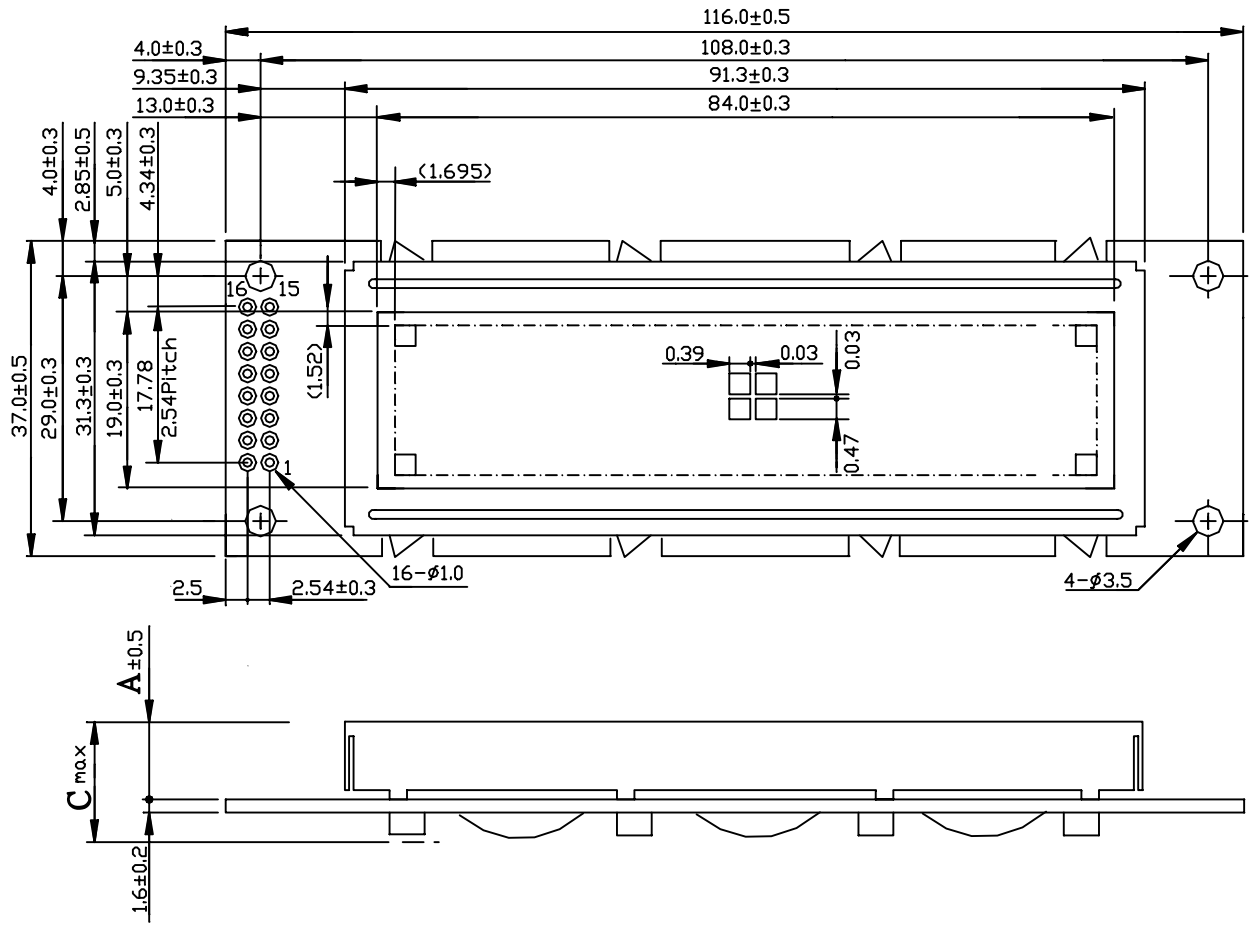

TYPE	A	C
LED B.L.	9.5	15.0
NO B.L.	4.9	10.0

NOTE :  
 1.UNIT : mm  
 2.SCALE : NTS

### 8.1 Interface pin connection

<i>PIN NO.</i>	<i>SYMBOL</i>	<i>FUNCTION</i>
1	V <sub>SS</sub>	POWER SUPPLY ( GND )
2	V <sub>DD</sub>	POWER SUPPLY ( +5V )
3	V <sub>o</sub>	POWER SUPPLY FOR LCD
4	RS	RS = "H" DB0~DB7 FOR DISPLAY DATA RS = "L" DB0~DB7 FOR CONTROL DATA
5	R $\overline{W}$	H: DATA READ ( LCD MODULE MPU ) L: DATA WRITE ( LCD MODULE MPU )
6	E	ENABLE SIGNAL
7	DB0	DATA INPUT/OUTPUT (LSB)
8	DB1	DATA INPUT/OUTPUT
9	DB2	DATA INPUT/OUTPUT
10	DB3	DATA INPUT/OUTPUT
11	DB4	DATA INPUT/OUTPUT
12	DB5	DATA INPUT/OUTPUT
13	DB6	DATA INPUT/OUTPUT
14	DB7	DATA INPUT/OUTPUT (MSB)
15	A(+)	POWER SUPPLY FOR LED (+)
16	K(-)	POWER SUPPLY FOR LED (-)

### 9. Block diagram

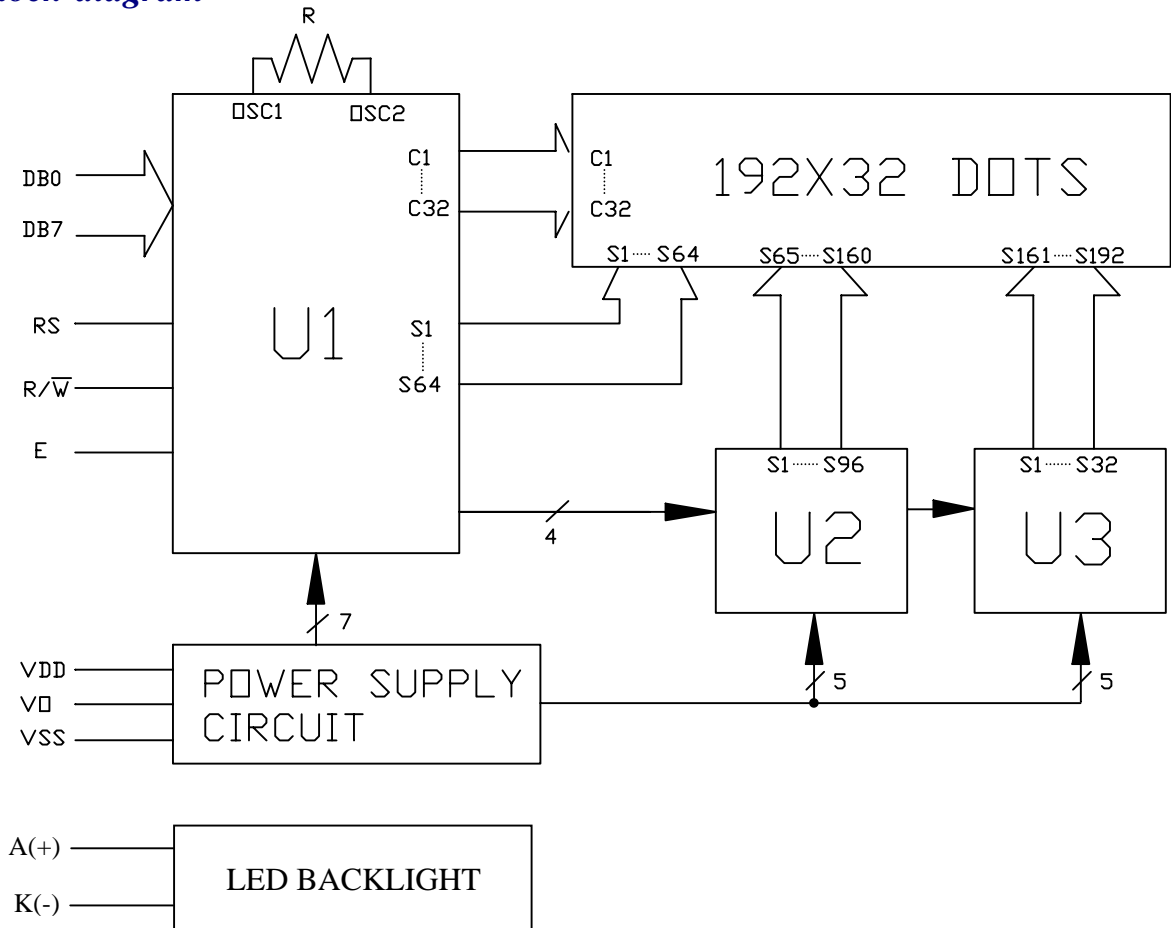

### 10. Power supply for LCM

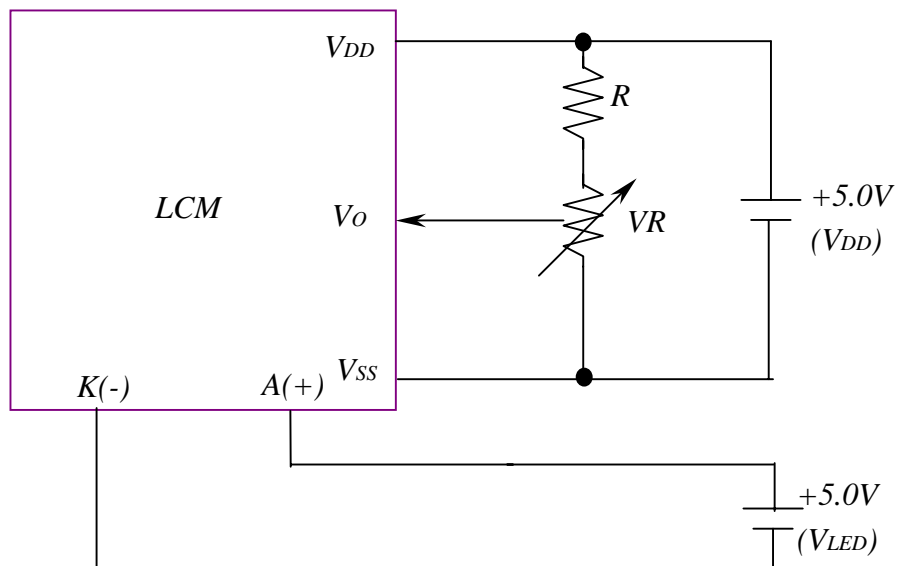

$V_o - V_{ss}$ : LCD DRIVING VOLTAGE

VR: 10KΩ~20KΩ