

# Switching Power Supply Type SPD 90W DIN rail mounting



- Installation on DIN Rail 7.5 or 15mm
- Short circuit protection
- PFC standard
- Power ready output
- LED indicator for DC power ON
- LED indicator for DC low
- Very compact dimensions
- UL, cUL listed and TUV/CE approved
- UL 1310 Class 2
- Class I Div 2 certification (in progress)

## Product Description

This SPD is the most compact 90W power supply on the market. Relay output for “power ready” function is included. Performances are unique with high efficiencies and the possibility of being used up to 70°C with a little derating.

## Ordering Key

**SP D 24 90 1 L**

Model \_\_\_\_\_  
 Mounting ( D = Din rail ) \_\_\_\_\_  
 Output voltage \_\_\_\_\_  
 Output power \_\_\_\_\_  
 Input type \_\_\_\_\_  
 Plastic enclosure \_\_\_\_\_

Input type: 1= single phase

## Approvals



## Output performances

Model	Rated output Voltage (VDC)	Output Power (W)	Output Current (A)	Voltage Trim Range		DC ON LED (VDC) Threshold at startup		DC LO LED (VDC) Threshold after startup		Typical Efficiency
				Min. VDC	Max. VDC	Min.	Max.	Min.	Max.	
SPD2490	24	91.2	3.8	22.5	24.5	17.6	19.4	17.6	19.4	85%

## Output Data

<b>Output voltage accuracy</b>	-0 +1% max (factory adjusted)	<b>Turn On Time</b>	
<b>Line regulation</b>	± 1%	$V_{i\ nom}, I_{o\ nom}$	1.0s
<b>Load regulation</b>		$V_{i\ nom}, I_{o\ nom}$ with Capacitor load	1.5s
Non parallel model	± 1%	<b>Rise Time</b>	
Parallel model	± 5%	$V_{i\ nom}, I_{o\ nom}$	150ms
<b>Temp. coefficient</b>	± 0.03% / °C	$V_{i\ nom}, I_{o\ nom}$ with Capacitor load	500ms
<b>Ripple and noise</b>	50mV	<b>Capacitor Load</b>	7000µF
$V_{i\ nom}, I_{o\ nom}, BW=20MHz$		<b>Reverse Voltage Immunity</b>	35V
<b>Rated continuous Loading</b>	3.8A @ 24VDC / 3.7A @ 24.5VDC	<b>Hold up Time <math>V_i = 115VAC</math> <math>I_{o\ nom}</math></b>	15ms
<b>Fall Time</b>	150ms	<b>Hold up Time <math>V_i = 230VAC</math> <math>I_{o\ nom}</math></b>	30ms
<b>Transient recovery time</b>		<b>Minimum load <math>V_{i\ nom}</math></b>	0%
$V_{i\ nom}, I_{o\ nom} = 0.5 \times I_{nom}$	2ms	<b>Parallel Operation</b>	No

## Input data

<b>Rated input voltage</b>	110/240	<b>Leakage Current</b>	
<b>Voltage range</b>		Input / Output	0.25mA
AC in	90 - 264VAC	Input / FG	3.5mA
DC in	120 - 375VDC	<b>Inrush current</b>	
<b>Rated input current</b>	1.65A / 1.4A	Vi= 115VAC	30A
<b>Power dissipation</b>	15W	Vi= 230VAC	60A
<b>Frequency range</b>	47- 63 Hz	<b>P.F.C.</b>	0.7
<b>Internal Voltage Surge Protection</b> (acc. to IEC61000-4-5)	Varistor		

## Controls and Protections

<b>Input Fuse</b>	T3.15/250VAC internal <sup>1)</sup>	<b>Power ready</b>	
<b>Output Short Circuit</b>	fold forward	Threshold at start up	Min. 17.6VDC - Max.19.4VDC
<b>Rated Overload Protection</b>	102 - 108%	(contact closed)	
<b>Over voltage protection</b> (auto recovery)	24.5V to 25.5V	Contact rating at 60VDC	0.3A
<b>Input Voltage Surge Protection</b>	Varistor	Insulation	500VDC

<sup>1)</sup> Fuse not replaceable by user

## General Data (@ nominal line, full load, 25°C )

<b>Ambient temperature</b>	-25°C to 71°C	<b>Switching frequency</b>	
<b>Derating (&gt;61°C to +71°C)</b>	2.5% / °C	Min.	45kHz
<b>Ambient humidity</b>	20 to 95%RH	Max.	60kHz
<b>Storage</b>	-25°C to +85°C	<b>MTBF (Bellcore Issue 6@40°C), GB</b>	493000h
<b>Pollution degree</b>	2	<b>Altitude during operation</b>	3.000m
<b>Protection degree</b>	IP20	<b>Case material</b>	Plastic
<b>Cooling</b>	Free air convection	<b>Dimensions L x W x D</b>	90 x 54 x 114mm
		<b>Weight</b>	430g

## Approvals and EMC

<b>Insulation voltage</b>	Input / Output 3.000VAC / 4242VDC Input / FG 1500VAC / 2121VDC	<b>CE</b>	EN 61000-6-3, EN 55022 Class B, EN 61000-3-2, EN 61000-3-3 EN 61000-6-2, EN 55024, EN 61000-4-2 Level 4, EN 61000-4-3 Level 3 EN 61000-4-4 Level 4, EN 61000-4-5 L-N Level 3, L / N-FG Level 4 EN 61000-4-6 Level 3, EN 61000-4-8 Level 4, EN 61000-4-11 ENV 50204 Level 2, EN 61204-3
<b>Insulation resistance</b>	100MΩ min		
<b>Shock resistance</b>	acc. to IEC 60068-2-27 (15G, 11ms, 3 Axis, 6 Faces, 3 times for each Face)		
<b>Vibration resistance</b>	acc. to IEC 60068-2-6 (Mounting by rail: 10-500 Hz, 2G, along X, Y, Z each Axis, 60 min for each Axis)		
<b>UL / cUL</b>	UL 508 Listed UL 60950-1, UL 1310 Class 2 Power Recognized ISA 12.12.01 (Class I, Division 2, Groups A, B, C and D in progress)		
<b>TUV</b>	EN 60950-1, CB scheme EN 61558-1, EN 61558-2-17 (acc.to EN 60204)		



## Block diagrams

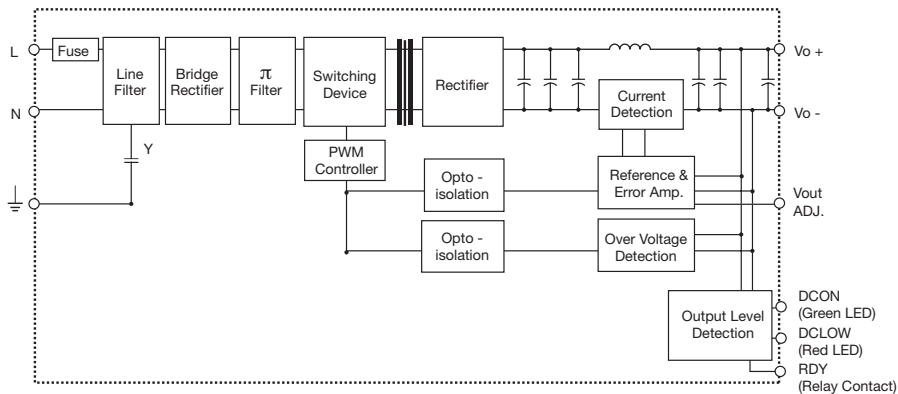

## Pin Assignment and front controls

Pin No.	Designation	Description
1	RDY	N.O. relay contact for DC OK (only SPD241001)
2	RDY	N.O. relay contact for DC OK (only SPD241001)
3	V+	Positive output terminal
4	V+	Positive output terminal
5	V-	Negative output terminal
6	V-	Negative output terminal
7	GND	Ground terminal to minimise High frequency emissions
8	N	Neutral input (no polarity with DC input)
9	L	Phase input (no polarity with DC input)
L1	DC ON	DC output ready LED
L2	DC LO	DC low indicator LED
POT1	Vout ADJ.	Trimmer for fine output voltage adjustment

## Typ. Efficiency Curve

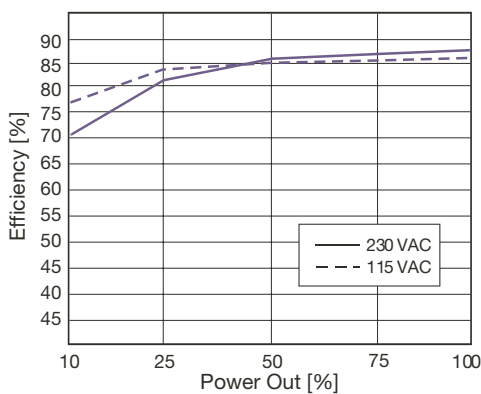

## Derating Diagram

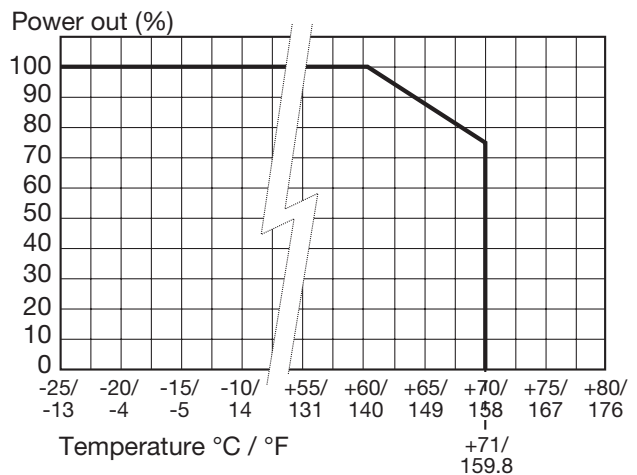

## Typ. Current Limited Curve

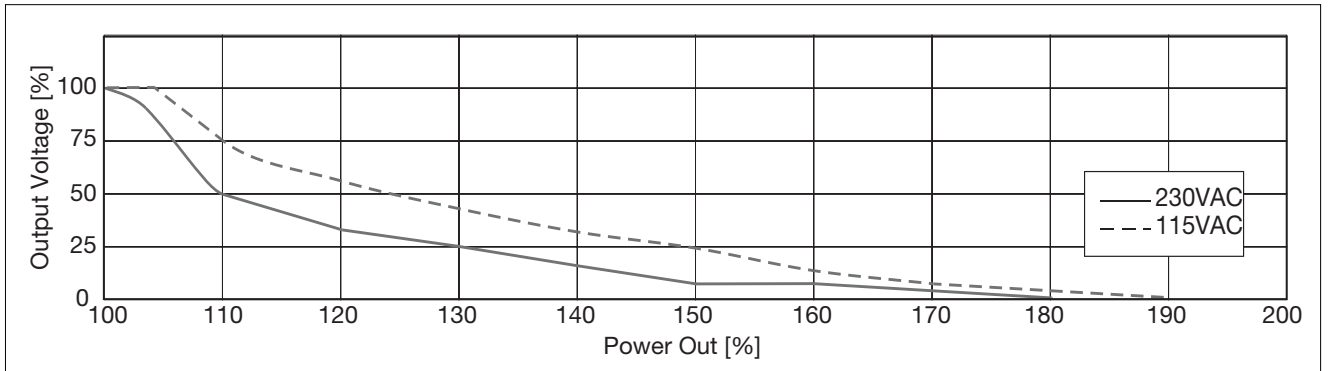

## Mechanical Drawings mm (inches)

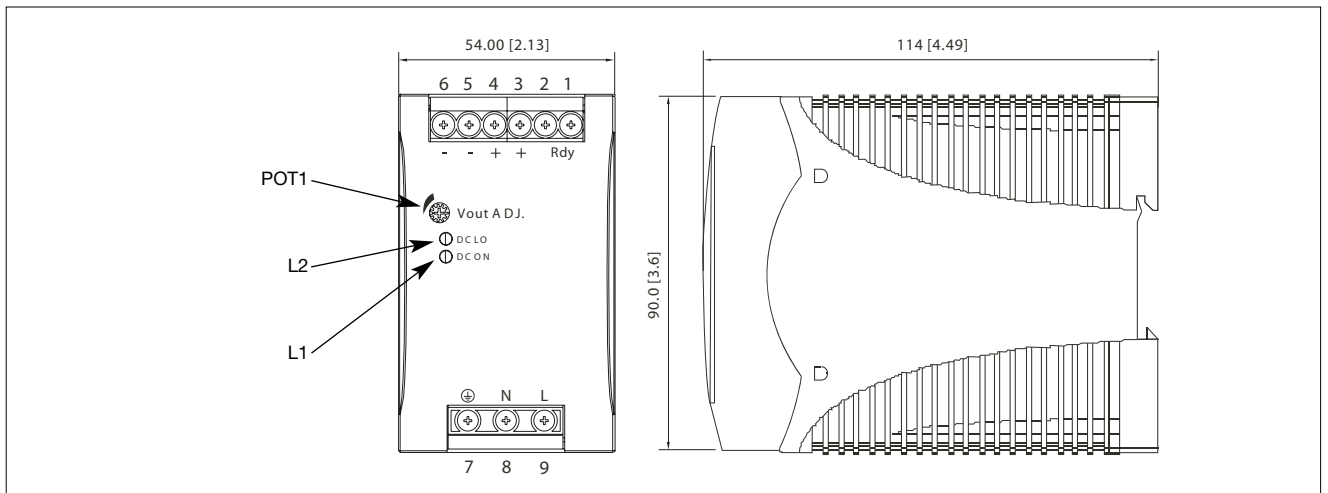

## Installation

<b>Ventilation and cooling</b>	Normal convection All sides 25mm free space for cooling is recommended
<b>Screw terminals</b>	10-24AWG flexible or solid cable 8mm stripping recommend
<b>Max. torque for screws terminals</b>	
Input terminals	1.008Nm (9.0lb-in)
Output terminals	0.616Nm (5.5lb-in)
<b>Plug-in connectors</b>	10-24AWG flexible or solid cable 7mm stripping recommend
<b>Max. torque for plug-in terminals</b>	
Input terminals	0.784Nm (7.0lb-in)
Output terminals	0.784Nm (7.0lb-in)
<b>Reccomended circuit breaker</b>	5A / 6A / 10A B, D characteristics