

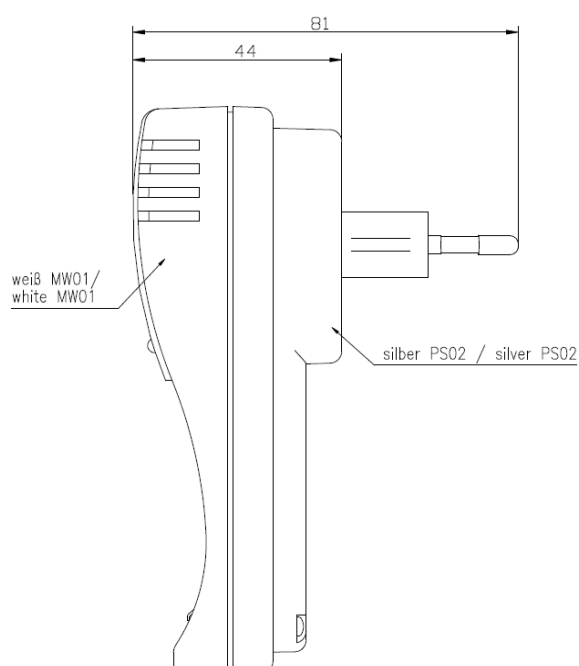

## Product datasheet

ENGLISH

# Basic 4 Plus Eu NiMH/NiCd battery charger

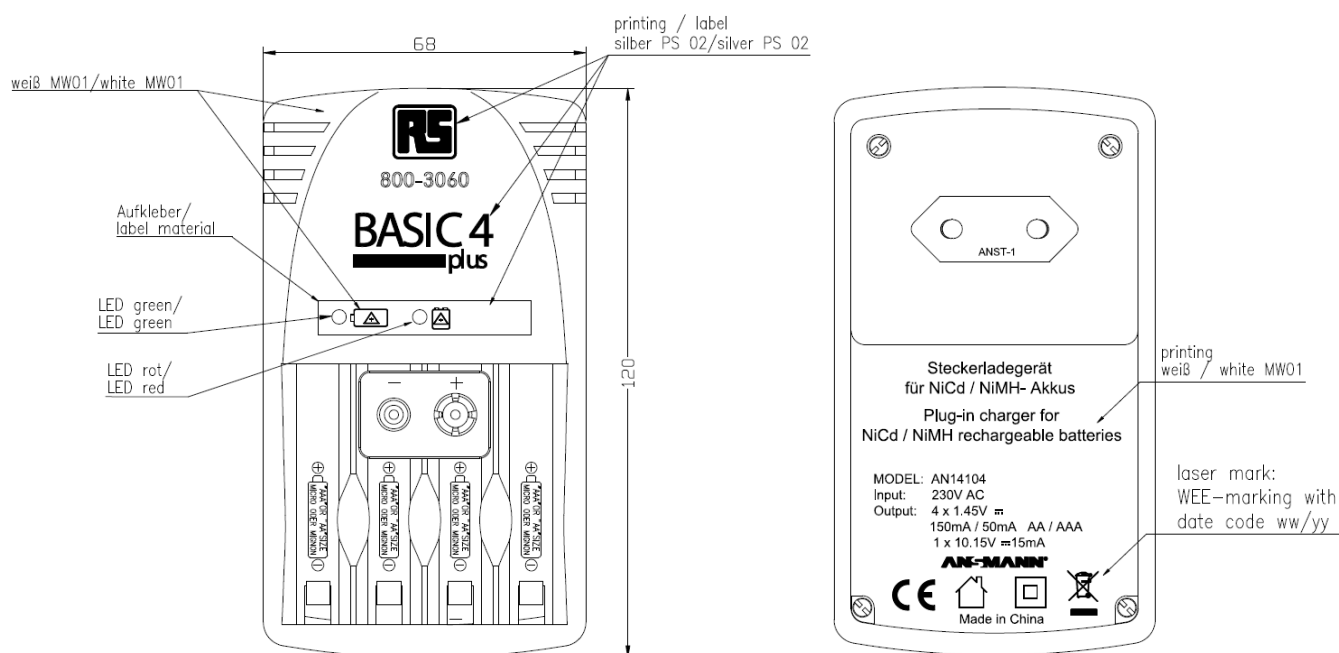



### Technical Data

Chemistry	NiMH/NiCd
No. of cells	1-4 x cylindrical cells, 1 x 9V block
Input voltage	230V AC $\pm$ 10%, 50Hz
Primary electrical protection	Fuse
Leakage current	<250 $\mu$ A
Nominal output voltage	4 x 1.45V (cylindrical cells), 1 x 10.15V (9V block)
Nominal charge current	AA 4 x 150mA $\pm$ 15% AAA 4 x 50mA $\pm$ 15% 9V block 1 x 15mA $\pm$ 15%
Secondary electrical protection	Mechanical against wrong polarity
Electric strength	4 kV primary/secondary
Protection class	II
Operating temperature	0 to +25°C
Storage temperature	-25 to +70°C
Case	Plug-in housing, white-silver
Case material	ABS plastic
PCB material	CEM1
Case protection	IP20
Rating plate front	Silver label with white printing
Rating plate back	White printing
Instructions	Multilingual operating instructions
Approvals	CE
Standards	IEC/EN 60335-1, IEC/EN 60335-2-29
Indicators	Cylindrical cells Green LED on during charge 9V block Red LED on during charge