

EBLOCKS[®]

Switch board

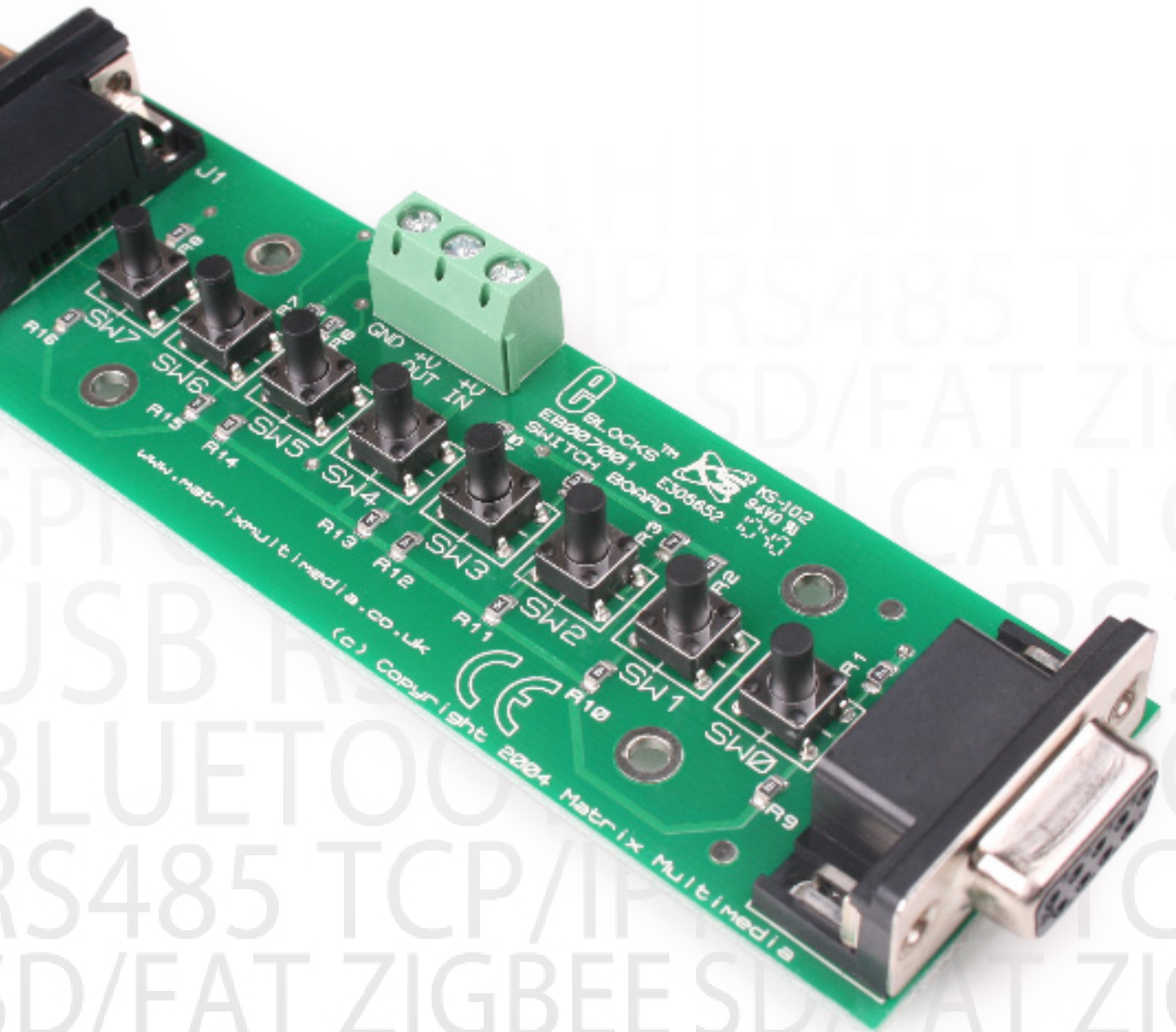

Contents

About this document	3
Board layout	3
General information	4
Circuit description	4
Protective cover	5
Circuit diagram	6

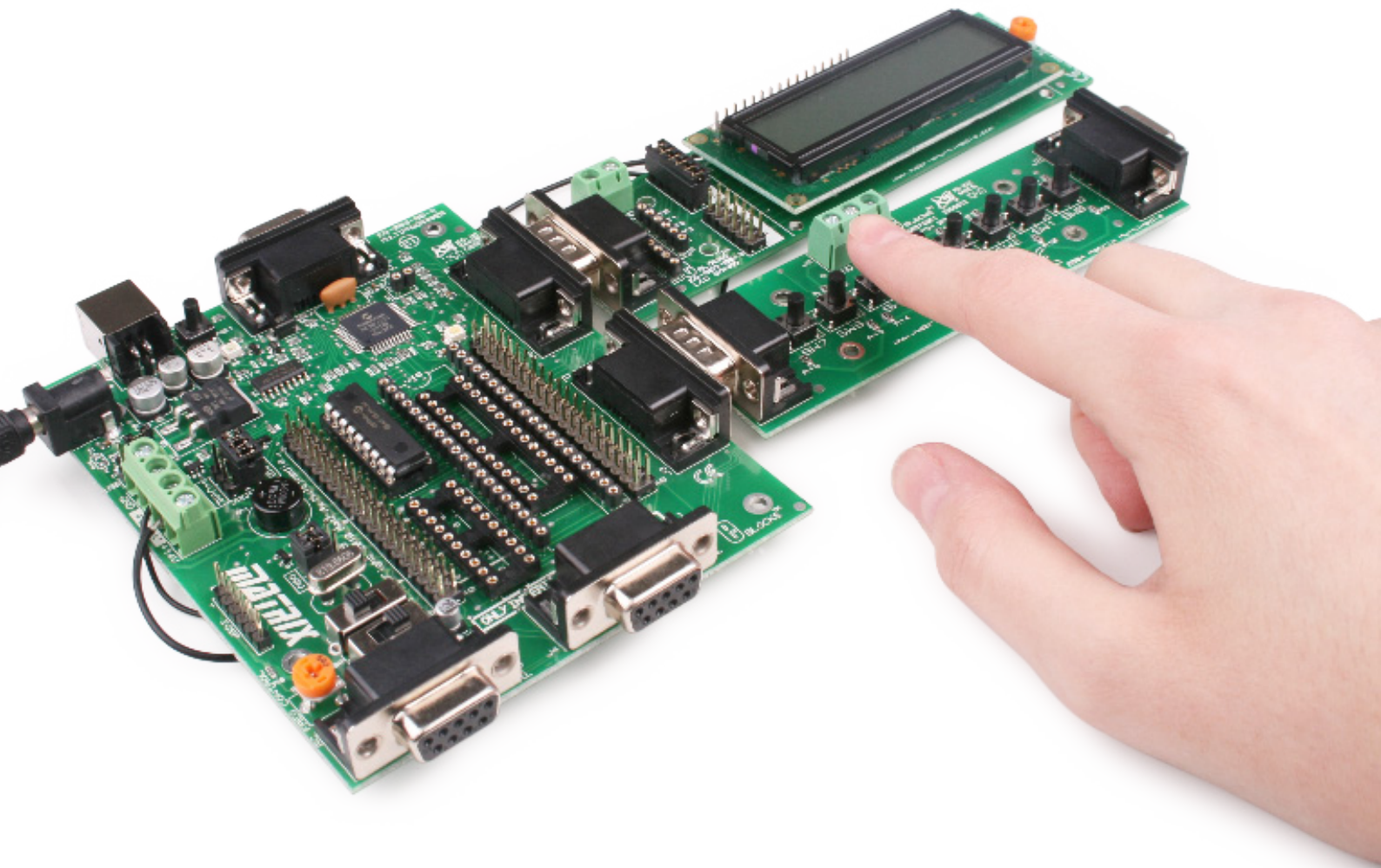

About this document

This document concerns the EB007 E-blocks switch board.

1. Trademarks and copyright

PIC and PICmicro are registered trademarks of Arizona Microchip Inc. E-blocks is a trademark of Matrix Technology Solutions Ltd.

2. Disclaimer

The information provided within this document is correct at the time of going to press. Matrix TSL reserves the right to change specifications from time to time.

3. Testing this product

It is advisable to test the product upon receiving it to ensure it works correctly. Matrix provides test procedures

for all E-blocks, which can be found in the Support section of the website.

4. Product support

If you require support for this product then please visit the Matrix website, which contains many learning resources for the E-blocks series. On our website you will find:

- How to get started with E-blocks - if you are new to E-blocks and wish to learn how to use them from the beginning there are resources available to help.
- Relevant software and hardware that allow you to use your E-blocks product better.
- Example files and programs.
- Ways to get technical support for your product, either via the forums or by contacting us directly.

Board layout

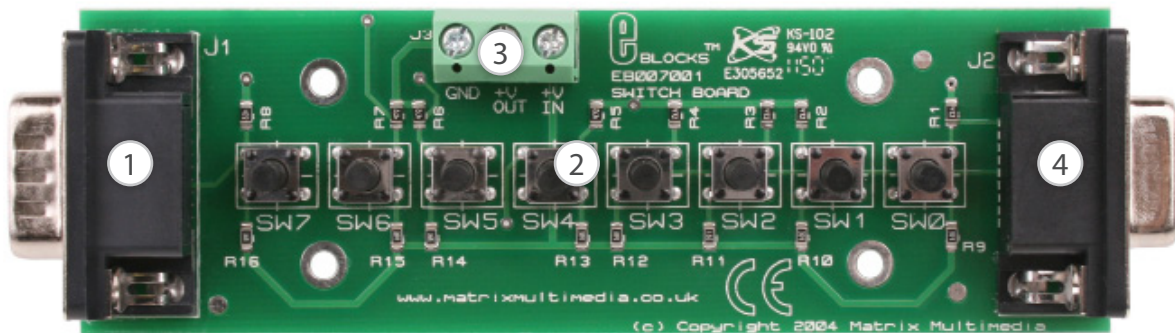

1. 9-way D-type plug
2. 8 x switches SW0 - SW7
3. Screw terminal
4. 9-way D-type socket

General information

This switch board allows you to connect up to 8 switches to any of the I/O ports on the E-blocks multiprogrammer board. The standard 9-way D-type connector associated with E-blocks makes the upstream and downstream connection. Further E-blocks can be connected to this E-block. The two D-type connectors provide a bus system that enables 'clean' access to all I/O lines. A +5 volt connection is required to enable the switching from logic level 0 (0V) to logic level 1 (+5V). Connecting a wire, using the screw terminal blocks provided on most E-blocks boards, makes this easily achievable.

1. Features
 - E-blocks compatible
 - Compatible with most I/O ports in the E-blocks range (up to 8 I/O lines via 9-way D-type connector)
 - Upstream and downstream D-type connector
 - 3.3 voltage compatible
2. Block schematic
 - Not supplied.

Circuit description

The EB007 switch board circuit can be observed on page 6.

The circuit board consists of 8 digital inputs on a downstream 9-way D-type plug. This routes each bit of the bus to an identical switch circuit and to a 9-way D-type socket that can be used for adding further E-blocks in a bus configuration.

This switch circuit board assumes that to operate correctly each input on the upstream processor board will be configured as a high impedance input. With this in mind each circuit consists of a 4k7 'pull down' resistor which, when the switch is open circuit, ensures a logic level 0 at the output from the switch board and into the

processor input pin. When a switch is pressed then the output from the switch board is effectively connected via a 390 ohm resistor to the positive rail (usually 5V), or to logic 1. When the switch is pressed the effect of the 4k7 pull down resistor in each circuit can be deemed to be negligible.

Care must be taken when connecting another E-block to the switch board. In this case users must make sure that the impedance placed on each line of the bus is such that the fundamental operation of the switch circuit is not impeded.

1. 3.3V operation
 - This board is compatible with 3.3V systems.

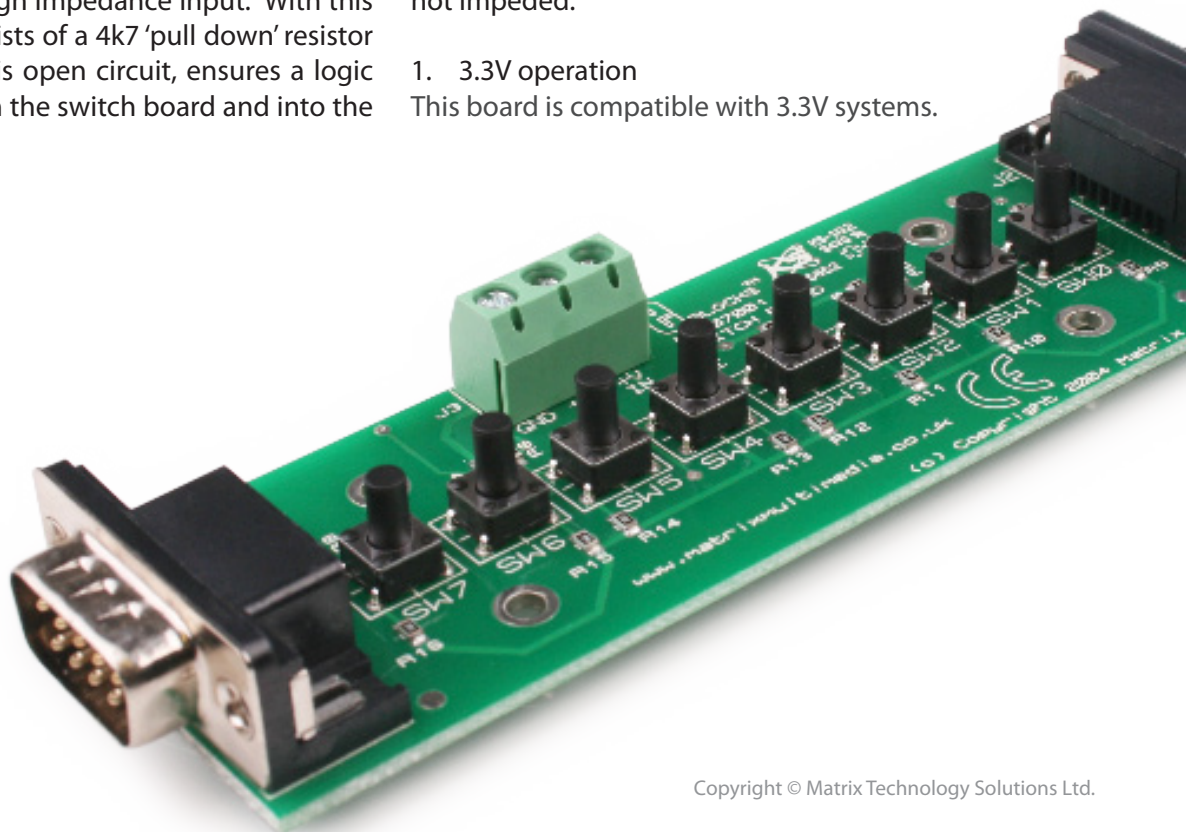

Protective cover

Most of the boards in the E-blocks range can be fitted with a plastic cover as an optional extra. These covers are there to protect your E-blocks board therefore extending the life of the board. The covers also prevent the removal of external components while still allowing for the adjustment of applicable parts on the board.

Unlike other E-blocks, because the switches are relatively short, the spacers are replaced with M3 lock nuts before the cover is put into place (see diagram below). These are not included but can be bought separately from our website.

The order code for the EB007 switch board is EB707.

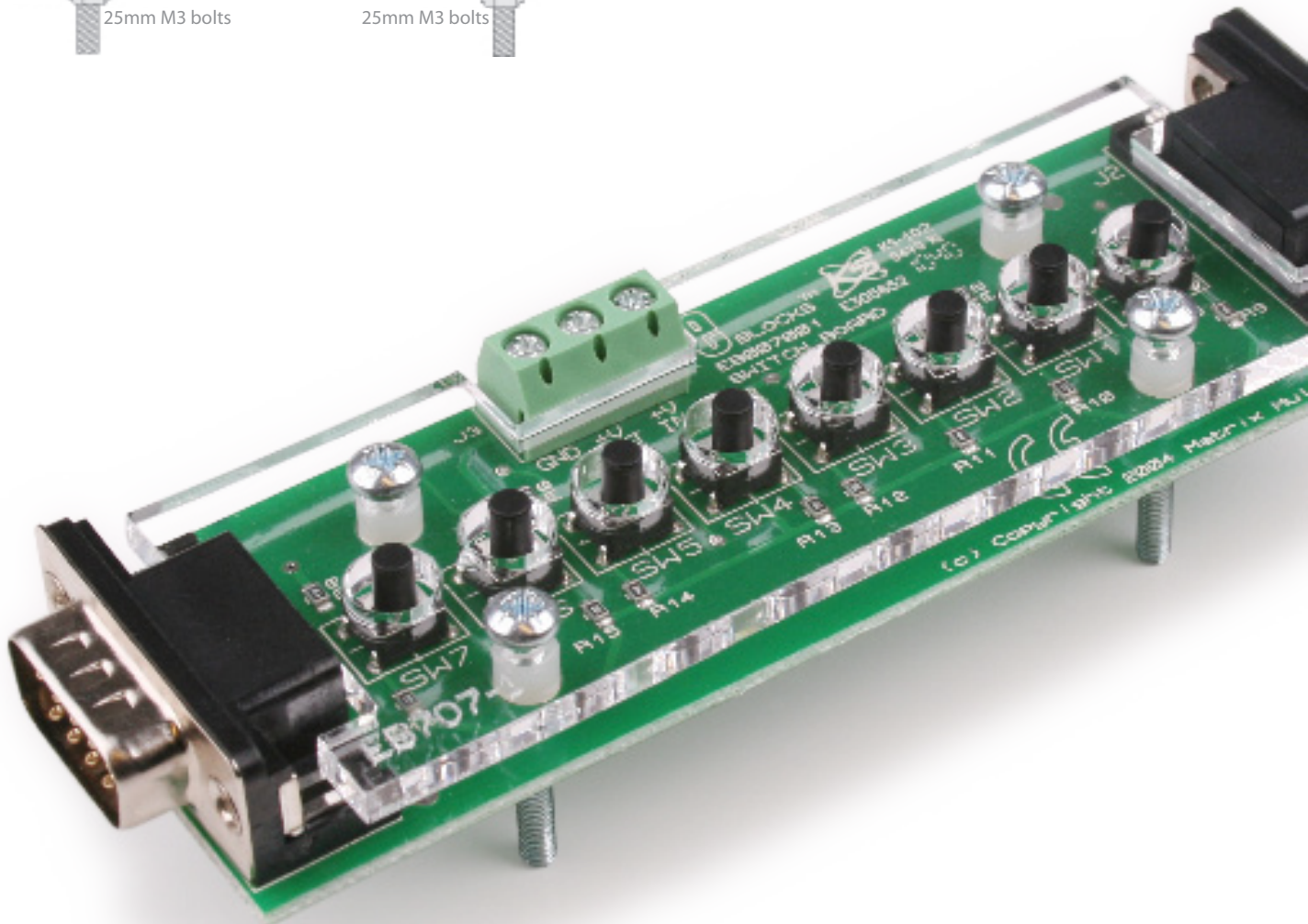
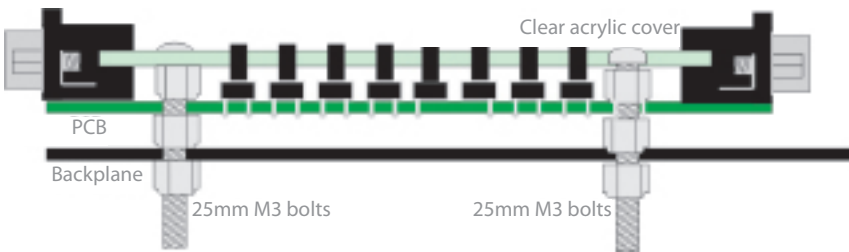

Circuit diagram

THIS SYSTEM INCLUDES:-

- F1 FEET
- F2 FEET
- F3 FEET
- F4 FEET
- B1 BAG
- L1 LABEL

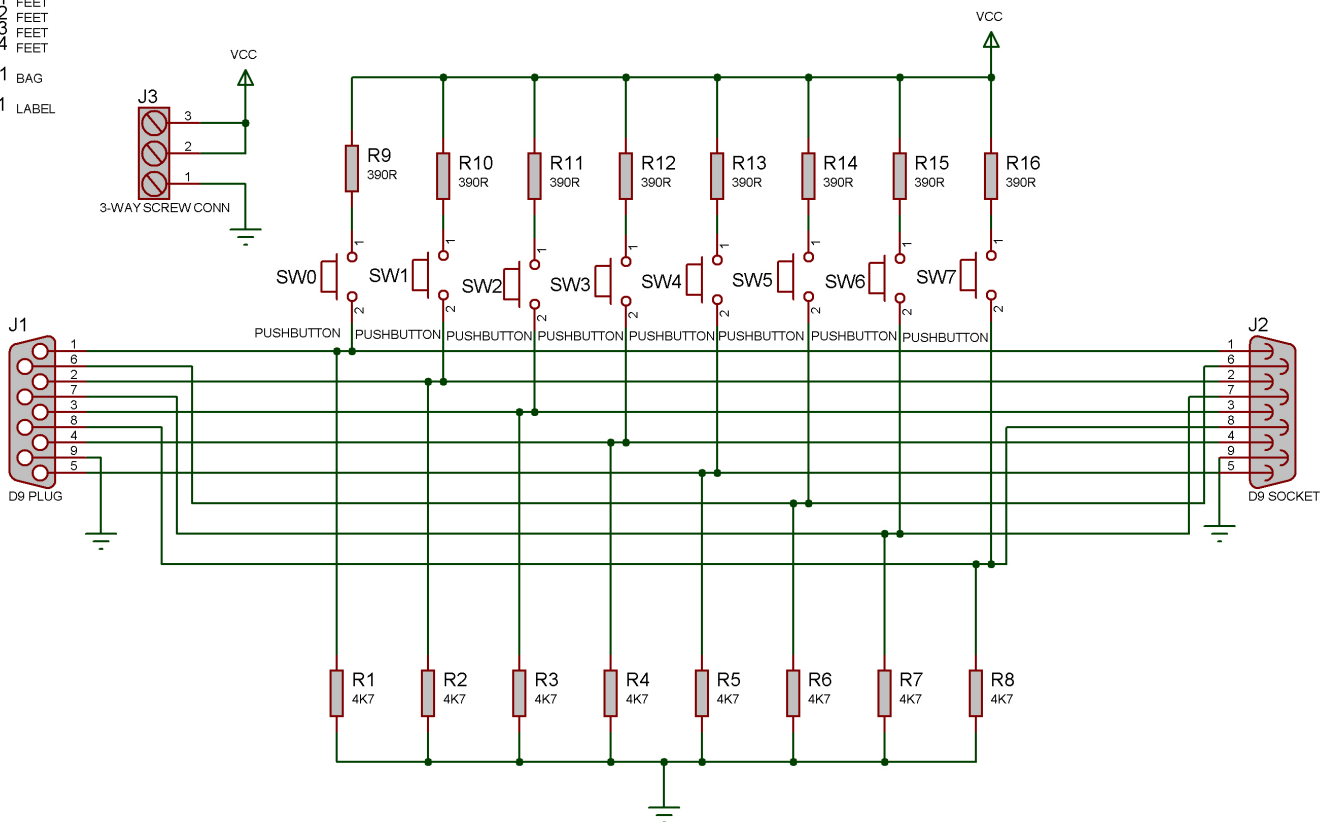



Matrix Technology Solutions Ltd.
The Factory
33 Gibbet Street
Halifax, HX1 5BA, UK

t: +44 (0)1422 252380
e: sales@matrixtsl.com

www.matrixtsl.com

EB007-30-1