

CIRCUIT BOARD HARDWARE

A

Part No.	"A" mm	"B" mm
TCBS-4-01	6.4	5.2
TCBS-6-01	9.5	5.2
TCBS-8-01	12.7	5.2
TCBS-10-01	15.9	7.9
TCBS-12-01	19.1	7.9
TCBS-14-01	22.2	7.9
TCBS-16-01	25.4	7.9
TCBS-18-01	28.6	7.9
TCBS-20-01	31.8	7.9
TCBS-22.5-01	35.7	7.9

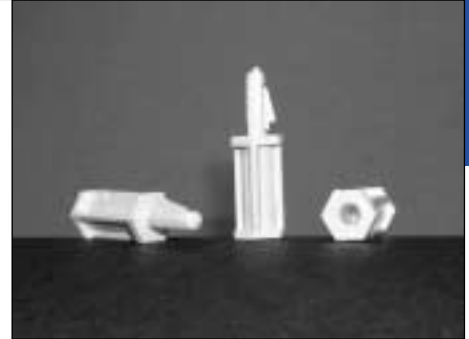
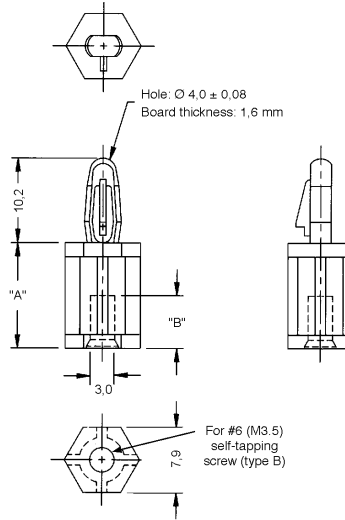

TCBS

SCREW MOUNT CIRCUIT BOARD SUPPORT

Material: Nylon 6/6 - natural; UL 94 V-2, RMS-01
or
Nylon 6/6 - natural; UL 94 V-0, RMS-19
Std. Pk.: 1.000 pcs.

Note:

