

HITACHI

KAOHSIUNG HITACHI ELECTRONICS CO.,LTD

FOR MESSRS : _____

DATE : Jan.14,2011

CUSTOMER'S ACCEPTANCE SPECIFICATIONS

TX09D40VM3CAA

CONTENTS

No.	ITEM	SHEET No.	PAGE
1	COVER	7B64PS 2701-TX09D40VM3CAA-3	1-1/1
2	RECORD OF REVISION	7B64PS 2702-TX09D40VM3CAA-3	2-1/1
3	GENERAL DATA	7B64PS 2703-TX09D40VM3CAA-3	3-1/1
4	ABSOLUTE MAXIMUM RATINGS	7B64PS 2704-TX09D40VM3CAA-3	4-1/2~2/2
5	ELECTRICAL CHARACTERISTICS	7B64PS 2705-TX09D40VM3CAA-3	5-1/2~2/2
6	OPTICAL CHARACTERISTICS	7B64PS 2706-TX09D40VM3CAA-3	6-1/2~2/2
7	BLOCK DIAGRAM	7B64PS 2707-TX09D40VM3CAA-3	7-1/1
8	INTERFACE TIMING CHART	7B64PS 2708-TX09D40VM3CAA-3	8-1/9~9/9
9	OUTLINE DIMENSIONS	7B64PS 2709-TX09D40VM3CAA-3	9-1/1
10	APPEARANCE STANDARD	7B64PS 2710-TX09D40VM3CAA-3	10-1/4~4/4
11	PRECAUTION IN DESIGN	7B64PS 2711-TX09D40VM3CAA-3	11-1/3~3/3
12	DESIGNATION OF LOT MARK	7B64PS 2712-TX09D40VM3CAA-3	12-1/1
13	PRECAUTION FOR USE	7B64PS 2713-TX09D40VM3CAA-3	13-1/1

ACCEPTED BY : _____

PROPOSED BY : Kent Chen

RECORD OF REVISION

DATE	SHEET No.	SUMMARY									
May.13,'08	7B64PS 2712- TX09D40VM3CAA-2 PAGE 12-1/1	12.1 LOT MARK Changed : 5 digits for production number ↓ 6 digits for production number 12.2 Location of lot mark Lot mark change: Print on FPC → Barcode label on frame									
Jan.14,'11	7B63PS 2709 – TX09D40VM3CAA-3 Page 9 – 1/1	9. OUTLINE DIMENSIONS The connectors on FPC changed.									
	7B64PS 2712 – TX09D40VM3CAA-3 Page 12 – 1/1	Added 12.2 REVISION (REV.) CONTROL <table border="1" style="margin-left: auto; margin-right: auto; border-collapse: collapse;"> <thead> <tr> <th style="width: 15%;">REV No.</th> <th style="width: 45%;">ITEM</th> <th style="width: 40%;">NOTE</th> </tr> </thead> <tbody> <tr> <td style="text-align: center;">A</td> <td style="text-align: center;">-</td> <td style="text-align: center;">-</td> </tr> <tr> <td style="text-align: center;">B</td> <td style="text-align: center;">Connectors changed</td> <td style="text-align: center;">PCN0804</td> </tr> </tbody> </table>	REV No.	ITEM	NOTE	A	-	-	B	Connectors changed	PCN0804
REV No.	ITEM	NOTE									
A	-	-									
B	Connectors changed	PCN0804									

3.GENERAL DATA

The specifications are applied to the following TFT-LCD (Transmissive with micro reflectance) module with Back-light unit and Touch Panel .

Note : Driving circuit for LED , timing controller and power unit are not built in this module.

(1) Part Name	TX09D40VM3CAA
(2) Module Dimensions	64.0(W)mm x 86.0(H)mm x 4.0(D)mm typ. (Except FPC Area)
(3) Effective Display Area	53.64(W)mm x 71.52(H)mm (Diagonal:9cm)
(4) Dot Pitch	0.0745mm x 3(R,G,B)(W) x 0.2235(H)mm
(5) Resolution	240 x 3(R,G,B)(W) x 320 (H) dots
(6) Color Pixel Arrangement	R,G,B Vertical Stripe
(7) LCD Type	Transmissive Color TFT LCD (Normally White)
(8) Display Type	Active Matrix
(9) Number of Colors	262 ^K Colors (R,G,B 6 Bit Digital each)
(10) Backlight	Light Emitting Diode (LED) x 6
(11) Weight	44g
(12) Interface	50 pin C-MOS
(13) Viewing Direction	3 O'clock (The direction it's hard to be discolored)
(14) Touch Panel	Resistance type . The surface is anti-glare

4. ABSOLUTE MAXIMUM RATINGS

4.1 ELECTRICAL ABSOLUTE MAXIMUM RATINGS OF LCD

ITEM		SYMBOL	MIN.	MAX.	UNIT	REMARKS
Power Supply for Logic		VCC	-0.3	3.6	V	
Power Supply Voltage for Source Driver and Vcom		VDH	-0.3	6.0	V	
Input Voltage		V_i	0	VCC	V	(1)
Gate	Power Supply for Gate	High	V_{GH}	-0.3	$V_{GL}+20$	V
		Low	V_{GL}	-9	0.3	V
LED	Forward Current		I_F	-	35	mA
	Pulse Forward Current		I_{FP}	-	100	mA
	Reverse Voltage		V_R	-	5	V
Static Electricity		-	-	± 2	kV	(4) (5)

Note (1) Hsync, Vsync, DCLK , R0~R5 , G0~G5 , B0~B5

(2)

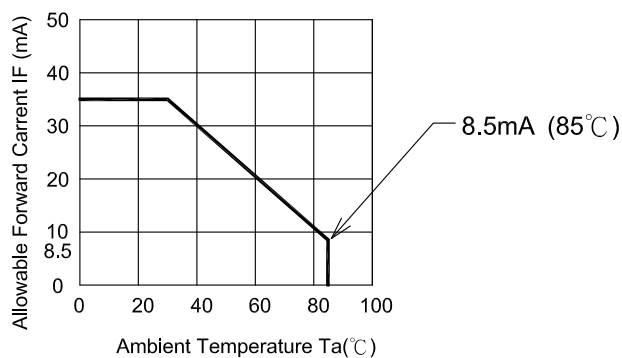

I_{FP} Conditions : pulse width $\leq 10\text{ms}$ and Duty $\leq 1/10$

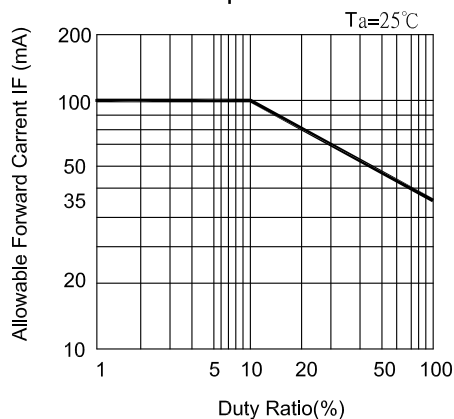

(6) Make certain you are grounded when handling LCM.

(7) Testing condition : 200pF - 0Ω , 25°C - 70%RH.

4.2 ELECTRICAL ABSOLUTE MAXIMUM RATINGS OF TOUCH PANEL

ITEM	SPECIFICATION	UNIT	CONDITION	REMARKS
Supply Voltage	7.0	V	DC	
Endurance Voltage	25	V	DC	(Note 1)

Note 1 : Waiting 1 minute.

4.3 ENVIRONMENTAL ABSOLUTE MAXIMUM RATINGS

ITEM	OPERATING		STORAGE		REMARKS
	Min.	Max.	Min.	Max.	
Ambient Temperature	-20°C	70°C	-30°C	80°C	(Note 2,3,6,7,9,10)
Humidity	(Note 1)		(Note 1)		Without condensation
Vibration	-	2.45m/s ² (0.25G)	-	11.76m/s ² (1.2G)	(Note 4,5)
Shock	-	29.4m/s ² (3G)	-	490m/s ² (50G)	(Note 5,8)
Corrosive Gas	Not Acceptable		Not Acceptable		

Note 1 : $T_a \leq 40^\circ\text{C}$: 85%RH max.

$T_a > 40^\circ\text{C}$: Absolute humidity must be lower than the humidity of 85%RH at 40°C .

Note 2 : For storage condition T_a at $-30^\circ\text{C} < 48\text{h}$, at $80^\circ\text{C} < 100\text{h}$.

For operating condition T_a at $-20^\circ\text{C} < 100\text{h}$

Note 3 : Background color changes slightly depending on ambient temperature.

This phenomenon is reversible.

Note 4 : 5Hz~100Hz(Except resonance frequency)

Note 5 : This LCM will resume normal operation after finishing the test.

Note 6 : The response time will be slower as low temperature.

Note 7 : Only operation is guaranteed at operating temperature. Contrast, response time, another display quality are evaluated at $+25^\circ\text{C}$.

Note 8 : Pulse Width : 10ms

Note 9 : This is panel surface temperature , not ambient temperature.

Note 10 : If LED is drive by high current , the life time of LED will be reduced , also high temperature and high humidity.

5. ELECTRICAL CHARACTERISTICS

5.1 ELECTRICAL CHARACTERISTICS OF LCD

Ta=25°C, VSS=0V

ITEM	SYMBOL	CONDITION	MIN.	TYP.	MAX.	UNIT
Power Supply Voltage for logic	VCC	-	2.5	3.0	3.3	V
Power Supply Voltage for Source Driver and Vcom	VDH	-	8.3	8.45	8.7	
Input voltage for logic (Note 1)	Vi	"H" level	0.8VCC	-	VCC	V
		"L" level	VSS	-	0.2VCC	
Power Supply for LCD	VGH	-	16.2	16.5	17.0	V
	VGL		-8.35	-8.05	-8.0	
	VCOM		VCOM-VSS	-	2.4	
Power Supply Current (Note 2)	ICC	VCC-VSS=3.0V	-	0.22	-	mA
	IDH	VDH-VSS=8.45V	-	3.3	-	
	IGH	VGH-VSS=16.5V	-	0.23	-	
	IGL	VGL-VSS=-8.05V	-	0.17	-	
Vsync Frequency	fV	-	54	60	68	Hz
Hsync Frequency	fH	-	18.57	20.77	22.73	kHz
DCLK Frequency	fCLK	-	5.0	5.6	6.5	MHz

Note 1 : DCLK, RD0~RD5, GD0~GD5, BD0~BD5.

Note 2 : fV=(60)Hz, Ta=25°C, Pattern used as display pattern : Black.

Note 3 : Need to made sure of flickering and rippling of display when setting the frame frequency in your set.

5.2 ELECTRICAL CHARACTERISTICS OF BACK LIGHT

ITEM	SYMBOL	CONDITION	MIN.	TYP.	MAX.	UNIT	REMARKS
LED Input Voltage	VF	IF=20mA	-	3.2	3.5	V	LED / Part
LED Forward Current	IF	-	-	20	25	mA	LED / Part
LED Reverse Current	IR	VR=5V	-	-	50	μA	LED / Part

5.3 ELECTRICAL CHARACTERISTICS OF TOUCH PANEL

ITEM		SPECIFICATION	UNIT
Resistance between Terminal	xR - xL	200 - 650	ohm
	yU - yL	250 - 500	ohm
Insulance Resistance (Note 1)	x - y	10M min.	ohm
Linearity (Note 2,3)	x	1.5 max.	%
	y	1.5 max.	%
Chattering		10 max.	ms

Note 1 : Operating Voltage 25V DC.

Note 2 : Test Condition.

(a) Y axis linearity testing method (with tip radius 0.8, polaycetal pen). $V_{xL-xR}=5V$, $V_{OUT}=V_{yU}$.

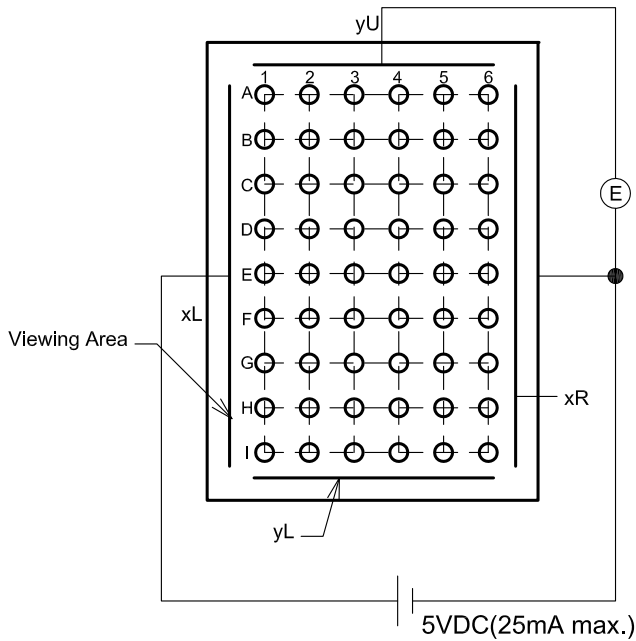

(b) X axis linearity method $V_{yU-yL}=5V$, $V_{OUT}=V_{xL}$.

Note 3 : Calculation

(a) Y axis linearity

$$\text{Linearity} = \frac{\Delta E \text{ max.}}{EA1 - EA6} \times 100(\%)$$

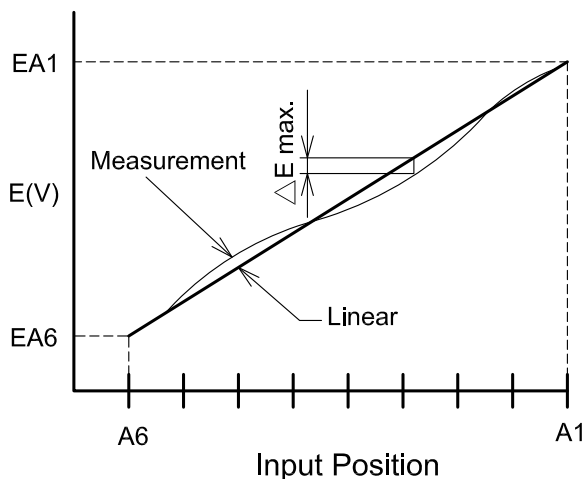

5.4 MECHANICAL CHARACTERISTICS OF TOUCH PANEL

ITEM	SPECIFICATION	UNIT	REMARKS
Pen Input Pressure	0.1 - 1.3	N	R0.8mm Polyacetal pen
Surface Hardness	3H min.	-	JIS K 5400

6. OPTICAL CHARACTERISTICS

6.1 OPTICAL CHARACTERISTICS OF LCD (BACK LIGHT ON)

Ta=25°C

ITEM	SYMBOL	CONDITION	MIN.	TYP.	MAX.	UNIT	NOTE	
Brightness	B	$\phi=0^\circ \theta=0^\circ$	290	340	-	cd/m ²	(1)	
Uniformity	-	$\phi=0^\circ \theta=0^\circ$	70	-	-	%	(2),(3),(4)	
Viewing Angle	θx	$\phi=0^\circ, K \geq 5.0$	-	50	-	deg	(5),(6)	
	$\theta x'$	$\phi=180^\circ, K \geq 5.0$	-	80	-			
	θy	$\phi=90^\circ, K \geq 5.0$	-	80	-			
	$\theta y'$	$\phi=270^\circ, K \geq 5.0$	-	80	-			
Contrast Ratio	K	$\phi=0^\circ \theta=0^\circ$	180	300	-	-	(4)	
Response Time (rise-fall)	tr+tf	$\phi=0^\circ \theta=0^\circ$	-	30	-	ms	(8)	
Color Tone (Primary Color)	Red	x	$\phi=0^\circ \theta=0^\circ$	0.54	0.59	0.64	-	(4)
		y		0.29	0.34	0.39	-	
	Green	x		0.31	0.36	0.41	-	
		y		0.51	0.56	0.61	-	
	Blue	x		0.10	0.15	0.20	-	
		y		0.08	0.13	0.18	-	
	White	x		0.28	0.33	0.38	-	
		y		0.29	0.34	0.39	-	

(Measurement condition : HITACHI standard)

Note 1 : Active area center

Note (4)~(7) : See page 6-2/2

Note 2 : Driving Condition

Display Pattern : White Raster

LED Current : 20mA / Part

Measurement of the following

5 places on the display.

Note 3 : Definition of the brightness uniformity

$$\left(\frac{\text{Min. brightness}}{\text{Max. brightness}} \right) \times 100\%$$

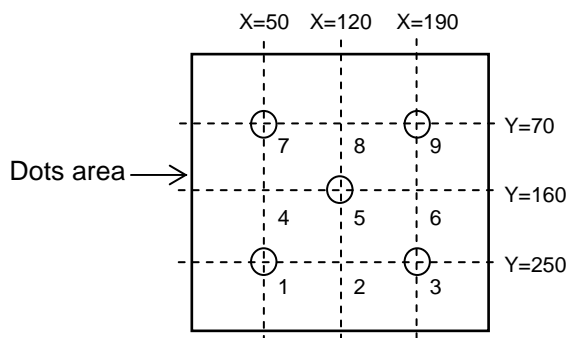

Note 4 : Measurement Condition

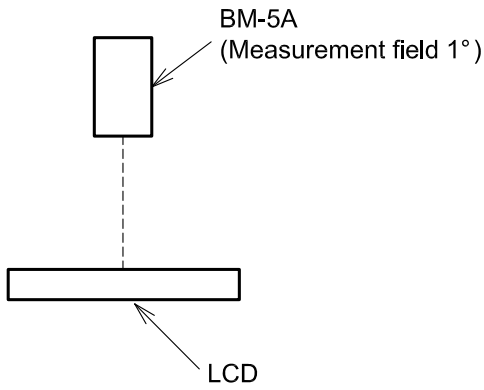

Note 5 : Definition of θ and ϕ
(Normal) Viewing direction

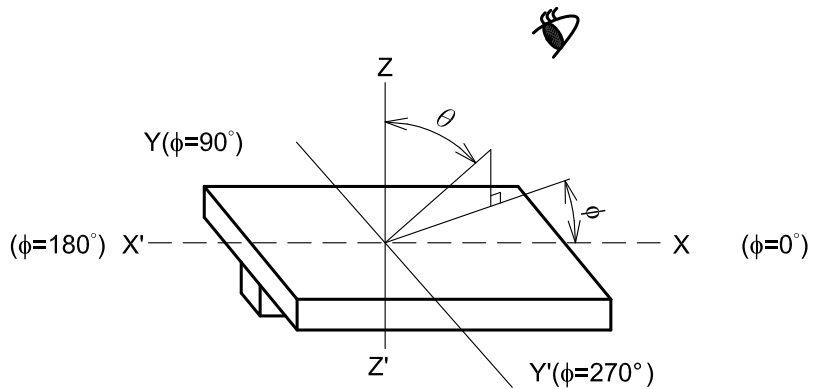

Note 6 : Definition of Viewing angle

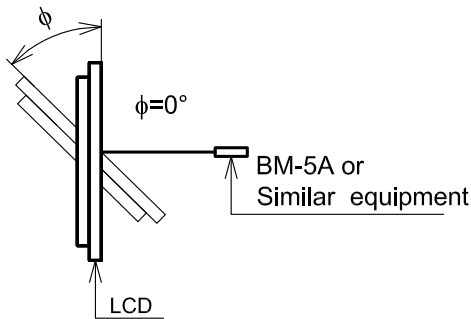

Note 7 : Definition of contrast "K"

$$K = \frac{\text{White Brightness}}{\text{Black Brightness}}$$

Note 8 : Definition optical response time

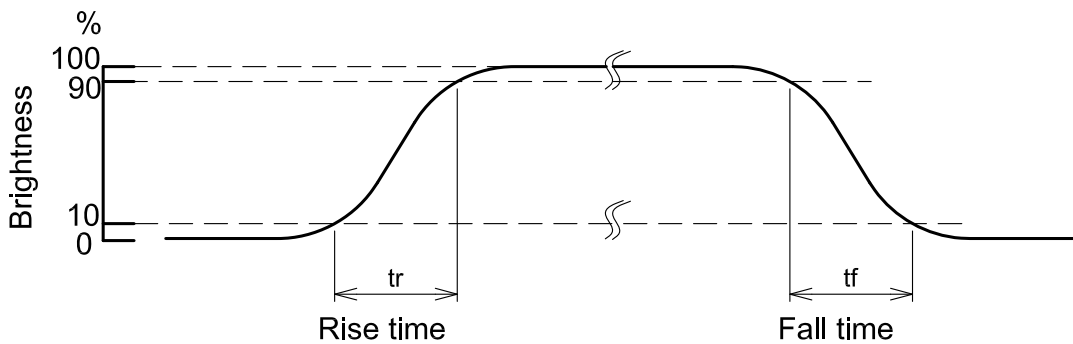
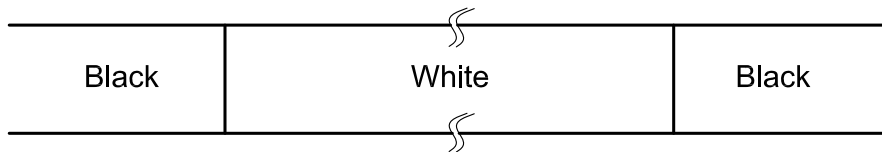

7. BLOCK DIAGRAM (REFERENCE ONLY)

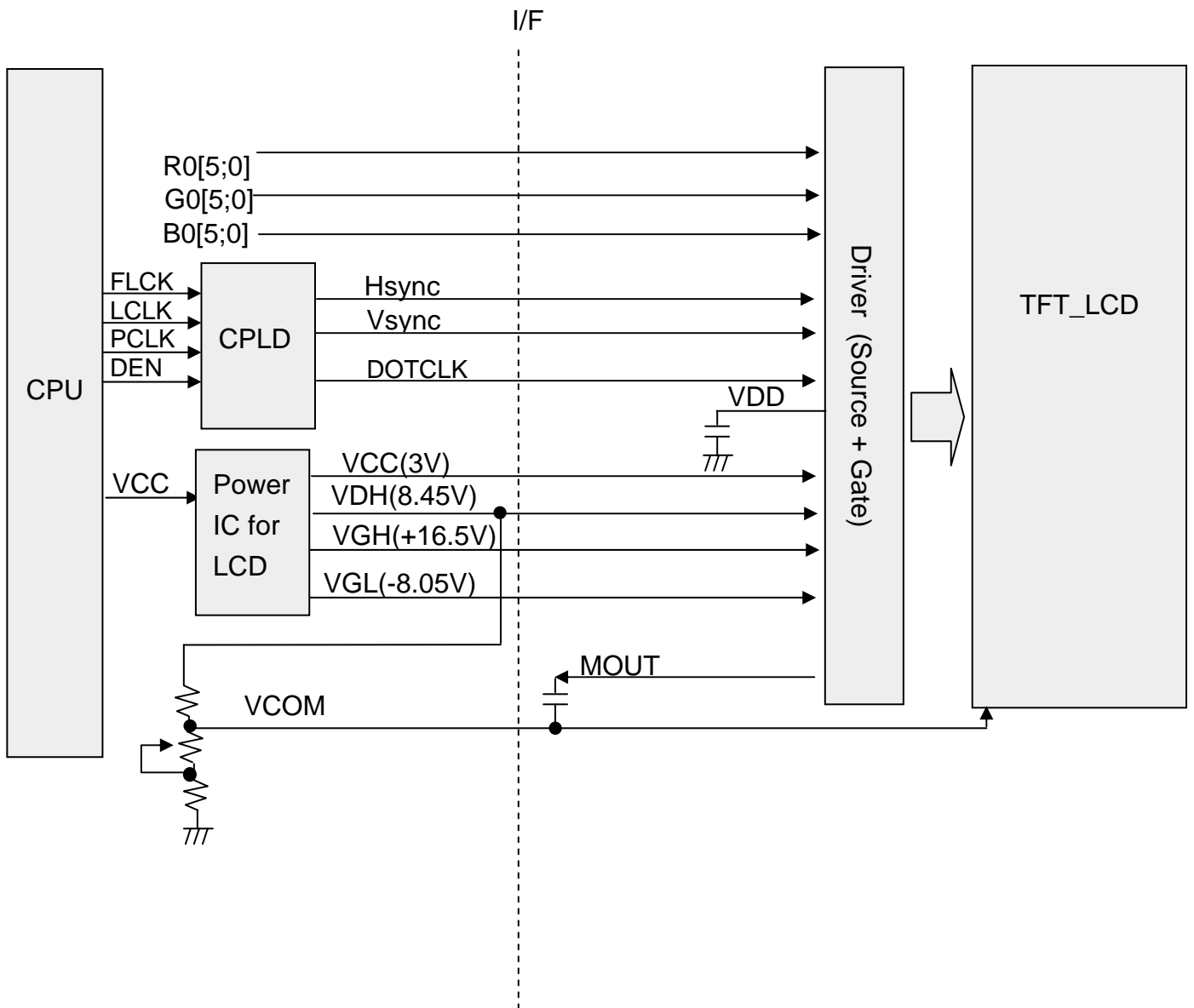

8. INTERFACE TIMING

8.1 INTERFACE TIMING

ITEM	SYMBOL	MIN.	TYP.	MAX.	UNIT	NOTE
DOTCLK cycle time	tCYCD	100	-	-	ns	1 trans
		50	-	-		3 trans
DOTCLK low level pulse width	PWDL	20	-	-	ns	-
DOTCLK high level pulse width	PWDH	20	-	-	ns	-
VSYNC setup time	tVSYNC	0	-	1	clock	-
HSYNC setup time	tHSYNC	0	-	1	clock	-
(ENABLE setup time)	tENS	20	-	-	ns	*
(ENABLE hold time)	tENH	20	-	-	ns	*
RGB data setup time	TPDS	20	-	-	ns	-
RGB data hold time	TPDH	20	-	-	ns	-
DOTCLK/VSYNC/HSYNC C rising edge, falling edge times	trgbr / trgbf	-	-	20	ns	-

*for the reference

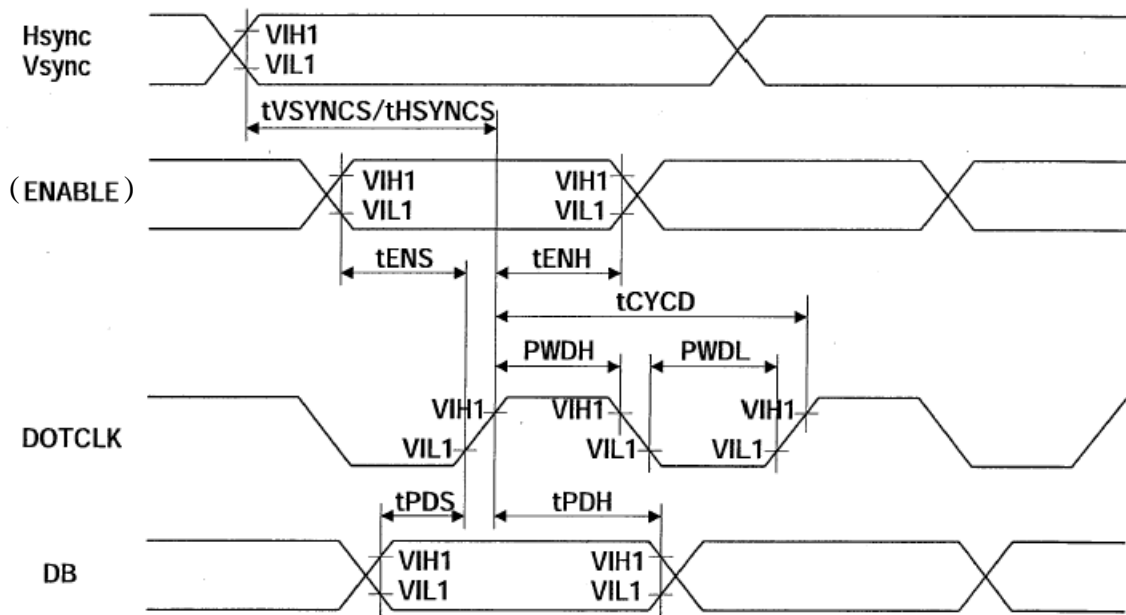

Fig1. RGB Interface timing

8.2 TIMING CHART

	SYMBOL	MIN.	TYP.	MAX.	UNIT
Back porch for Horizontal	HBP	-	12	-	Clock
Front porch for Horizontal	HFP	15	18 Note(1)	21	Clock
Back porch for Vertical	VBP	-	8 Note(3)	-	HSYNC
Front porch for Vertical	VFP	17	(20) Note(2)	22	HSYNC

Note(1) : (DOTCLK total) - ((Valid data period for Horizontal) + (HBP))

(2) : (HSYNC total) - ((Active Area period) + VBP)

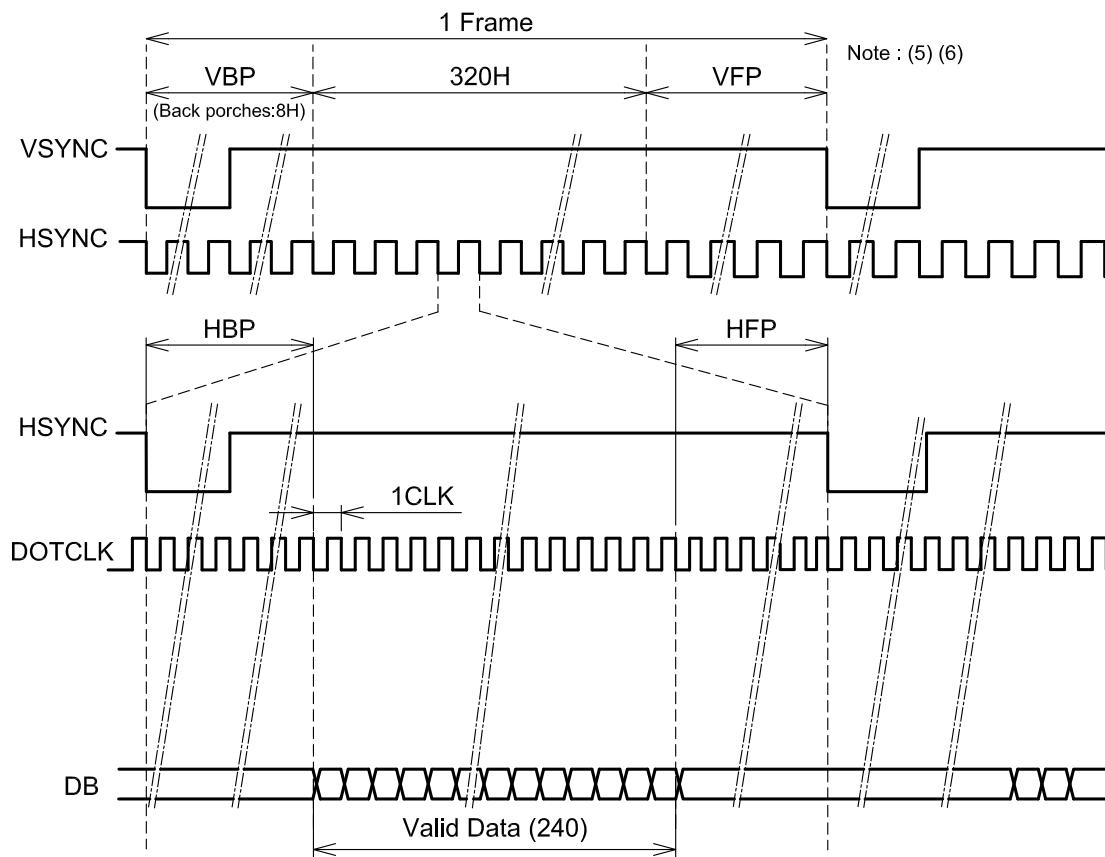

(3) Note about VSYNC timing setting

Check the timing chart of VSYNC and HSYNC , If timing setting is not set as fig1, it must be set as fig2 .

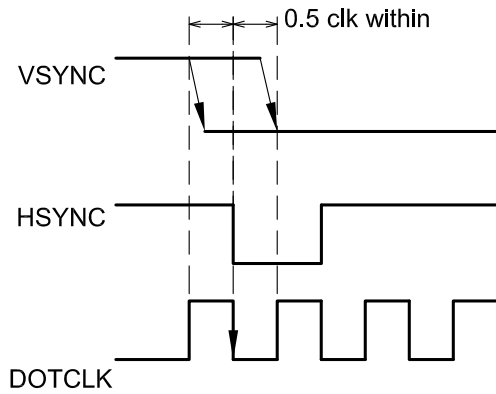

fig1. VSYNC timing

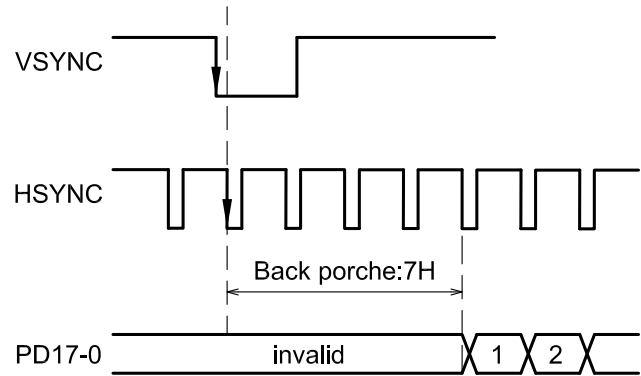
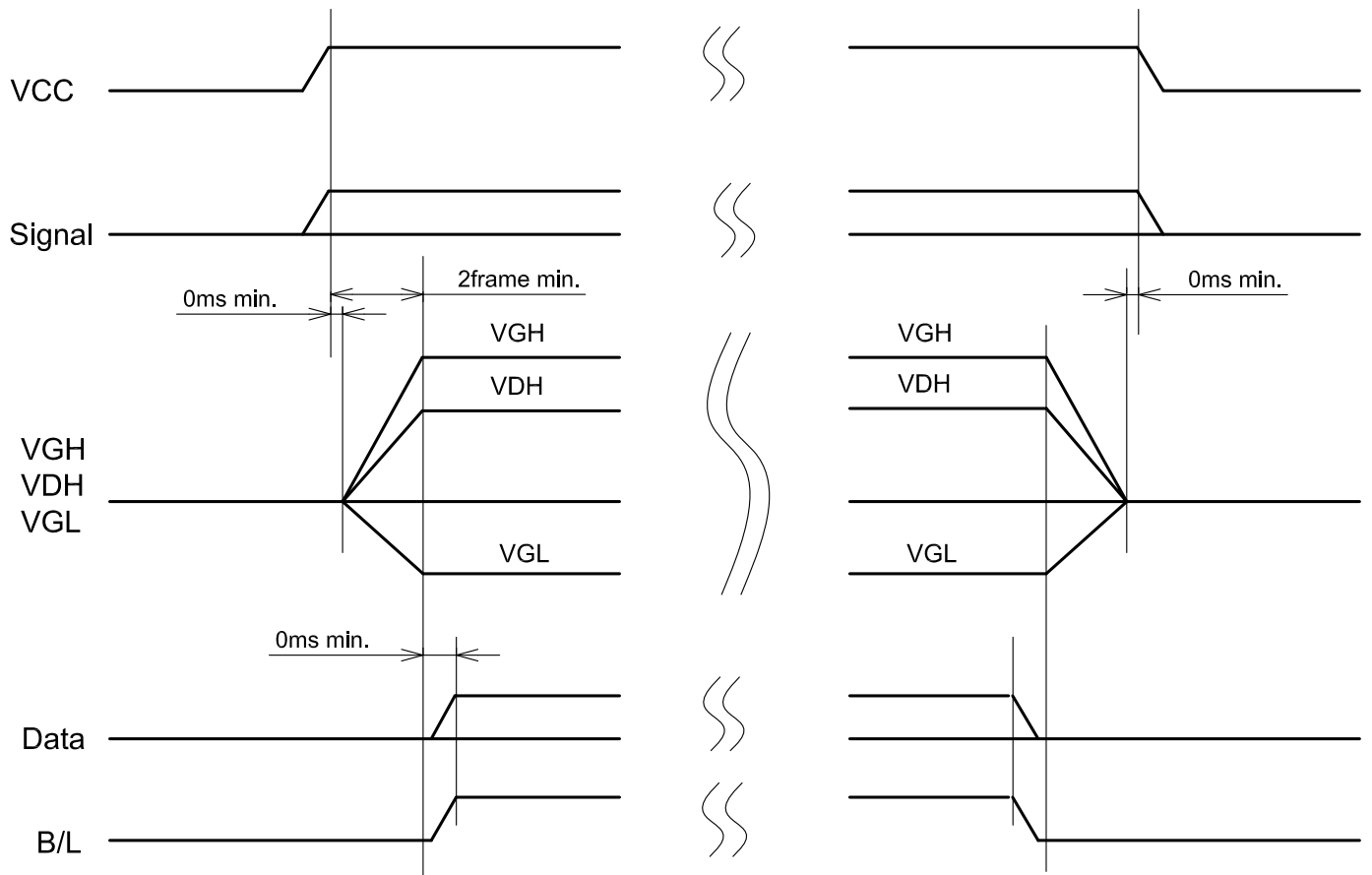

fig2. Vertical back porch regulation

- (4) The DOTCLK signal must be supplied consecutively.
- (5) Front and back porches (VBP , VFP) must be set before and after the display operation period.
- (6) The front porch period continues until the next input of VSYNC signal.

8.3 POWER ON/OFF SEQUENCE



8.4 RELATIONSHIP BETWEEN DISPLAYED COLOR AND INPUT DATA

8.4.1 Display Colors

Input color		Red Data						Green Data						Blue Data					
		R5	R4	R3	R2	R1	R0	G5	G4	G3	G2	G1	G0	B5	B4	B3	B2	B1	B0
		MSB			LSB			MSB			LSB			MSB			LSB		
Basic Color	Black	0	0	0	0	0	0	0	0	0	0	0	0	0	0	0	0	0	0
	Red(0)	1	1	1	1	1	1	0	0	0	0	0	0	0	0	0	0	0	0
	Green(0)	0	0	0	0	0	0	1	1	1	1	1	1	0	0	0	0	0	0
	Blue(0)	0	0	0	0	0	0	0	0	0	0	0	0	1	1	1	1	1	1
	Cyan	0	0	0	0	0	0	1	1	1	1	1	1	1	1	1	1	1	1
	Magenta	1	1	1	1	1	1	0	0	0	0	0	0	1	1	1	1	1	1
	Yellow	1	1	1	1	1	1	1	1	1	1	1	1	0	0	0	0	0	0
	White	1	1	1	1	1	1	1	1	1	1	1	1	1	1	1	1	1	1
Red	Black	0	0	0	0	0	0	0	0	0	0	0	0	0	0	0	0	0	0
	Red(62)	0	0	0	0	0	1	0	0	0	0	0	0	0	0	0	0	0	0
	Red(61)	0	0	0	0	1	0	0	0	0	0	0	0	0	0	0	0	0	0
	:	:	:	:	:	:	:	:	:	:	:	:	:	:	:	:	:	:	:
	:	:	:	:	:	:	:	:	:	:	:	:	:	:	:	:	:	:	:
	Red(2)	1	1	1	1	0	1	0	0	0	0	0	0	0	0	0	0	0	0
	Red(1)	1	1	1	1	1	0	0	0	0	0	0	0	0	0	0	0	0	0
	Red(0)	1	1	1	1	1	1	0	0	0	0	0	0	0	0	0	0	0	0
Green	Black	0	0	0	0	0	0	0	0	0	0	0	0	0	0	0	0	0	0
	Green(62)	0	0	0	0	0	0	0	0	0	0	1	0	0	0	0	0	0	0
	Green(61)	0	0	0	0	0	0	0	0	0	1	0	0	0	0	0	0	0	0
	:	:	:	:	:	:	:	:	:	:	:	:	:	:	:	:	:	:	:
	:	:	:	:	:	:	:	:	:	:	:	:	:	:	:	:	:	:	:
	Green(2)	0	0	0	0	0	0	1	1	1	1	0	1	0	0	0	0	0	0
	Green(1)	0	0	0	0	0	0	1	1	1	1	1	0	0	0	0	0	0	0
	Green(0)	0	0	0	0	0	0	1	1	1	1	1	1	0	0	0	0	0	0
Blue	Black	0	0	0	0	0	0	0	0	0	0	0	0	0	0	0	0	0	0
	Blue(62)	0	0	0	0	0	0	0	0	0	0	0	0	0	0	0	0	0	1
	Blue(61)	0	0	0	0	0	0	0	0	0	0	0	0	0	0	0	0	1	0
	:	:	:	:	:	:	:	:	:	:	:	:	:	:	:	:	:	:	:
	:	:	:	:	:	:	:	:	:	:	:	:	:	:	:	:	:	:	:
	Blue(2)	0	0	0	0	0	0	0	0	0	0	0	0	1	1	1	1	0	1
	Blue(1)	0	0	0	0	0	0	0	0	0	0	0	0	1	1	1	1	1	0
	Blue(0)	0	0	0	0	0	0	0	0	0	0	0	0	1	1	1	1	1	1

8.5 POWER SUPPLY CIRCUIT FOR LCD (REFERENCE ONLY)

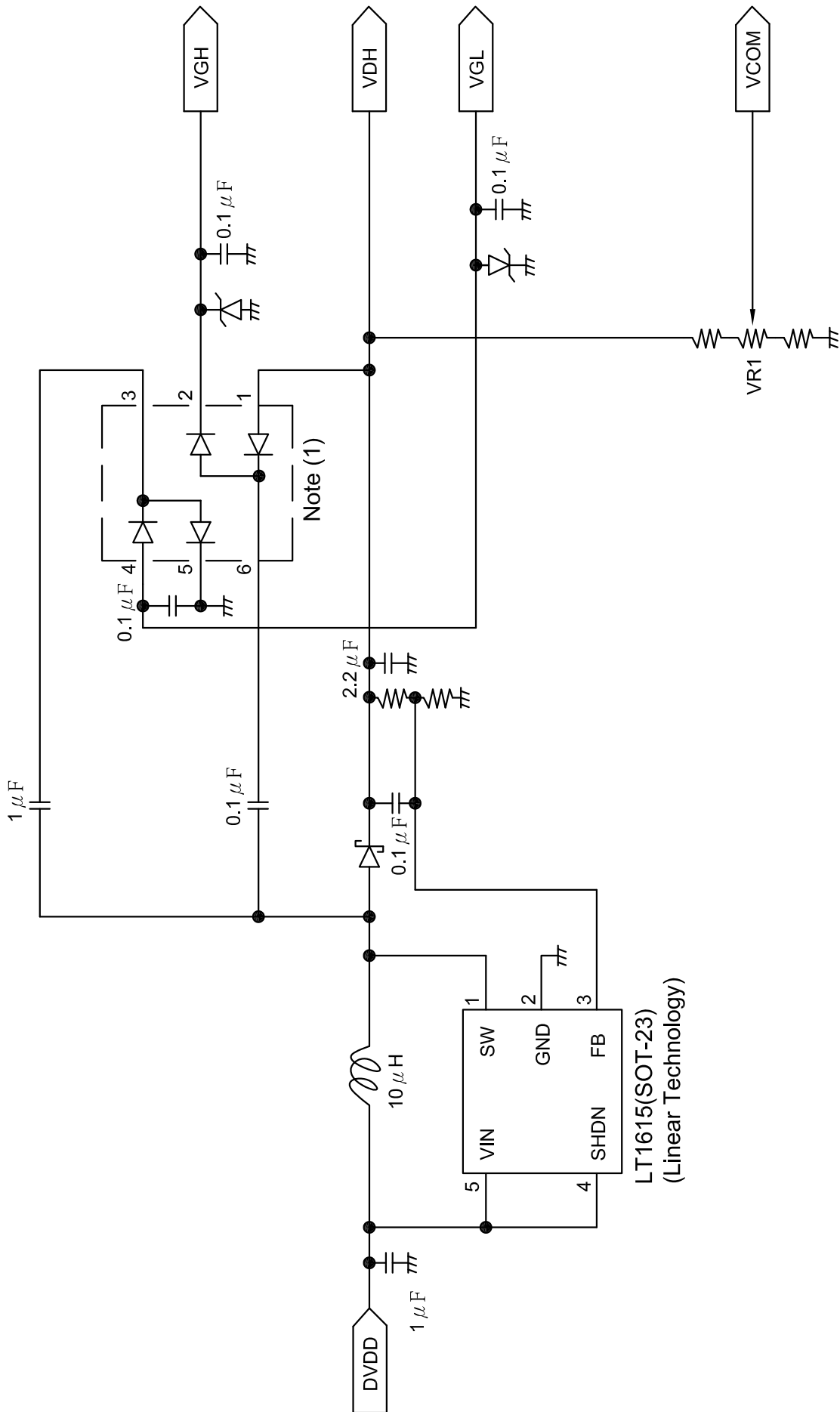

Note 1 : Must uses shottky barrier diode, and forward voltage is 0.4V (typ.)

8.6 POWER SUPPLY CIRCUIT FOR LED BL (REFERENCE ONLY)

Example 1.
LED B/L

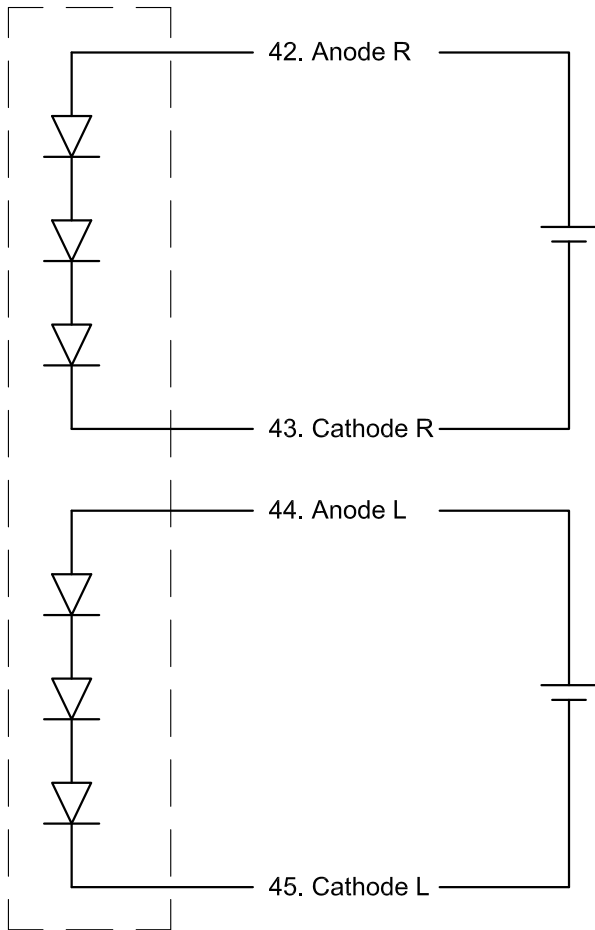

Example 2.
LED B/L

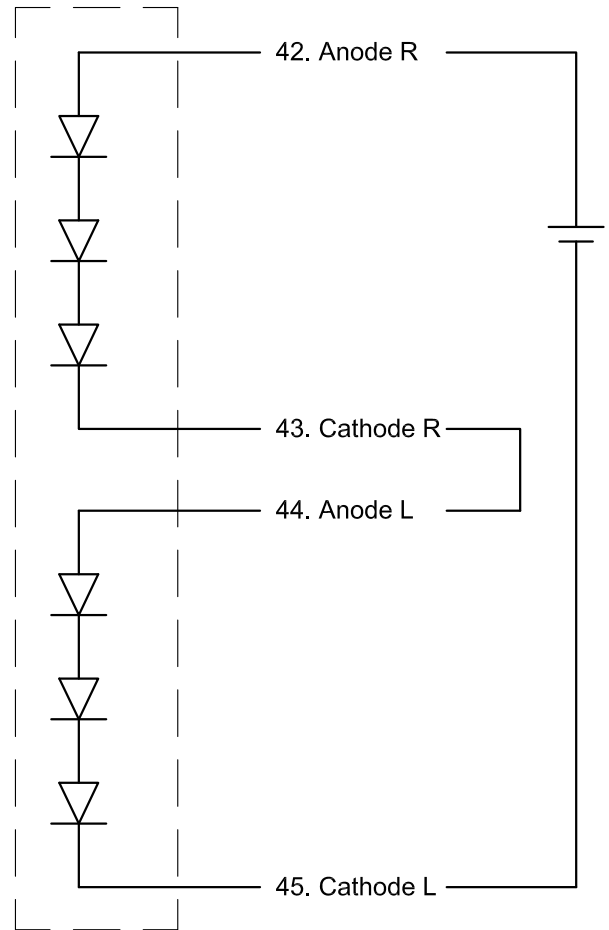

8.7 INTERNAL PIN CONNECTION

Suitable connector : FH12-50S-0.5P

No	SYMBOL	FUNCTION	No	SYMBOL	FUNCTION
1	VGH	Power Supply for Gate Driver (High)	26	B5	Blue Data (MSB)
2	NC	No Connection by FPC Side	27	NC	No Connection by FPC Side
3	NC	No Connection by FPC Side	28	Vsync	Vertical Sync Signal
4	NC	No Connection by FPC Side	29	NC	No Connection by FPC Side
5	GND	Ground	30	DOTCLK	Dot Clock Signal
6	VGL	Power Supply for Gate Driver (Low)	31	NC	No Connection by FPC Side
7	VSS	Ground	32	NC	No Connection by FPC Side
8	Hsync	Horizontal Sync Signal	33	VDH	Power Supply for Source Driver
9	R0	Red Data (LSB)	34	VDH	Power Supply for Source Driver
10	R1	Red Data	35	NC	No Connection by FPC Side
11	R2	Red Data	36	NC	No Connection by FPC Side
12	R3	Red Data	37	VCC	Power Supply for Logic
13	R4	Red Data	38	VCC	Power Supply for Logic
14	R5	Red Data (MSB)	39	VCOM	Common Voltage
15	G0	Green Data (LSB)	40	VCOM	Common Voltage
16	G1	Green Data	41	VSS	Ground
17	G2	Green Data	42	Anode R	LED Power Supply (+)
18	G3	Green Data	43	Cathode R	LED Power Supply (-)
19	G4	Green Data	44	Anode L	LED Power Supply (+)
20	G5	Green Data (MSB)	45	Cathode L	LED Power Supply (-)
21	B0	Blue Data (LSB)	46	VSS	Ground
22	B1	Blue Data	47	xR	Touch Panel Right Side
23	B2	Blue Data	48	yL	Touch Panel Lower Side
24	B3	Blue Data	49	xL	Touch Panel Left Side
25	B4	Blue Data	50	yU	Touch Panel Upper Side

9.OUTLINE DIMENSIONS

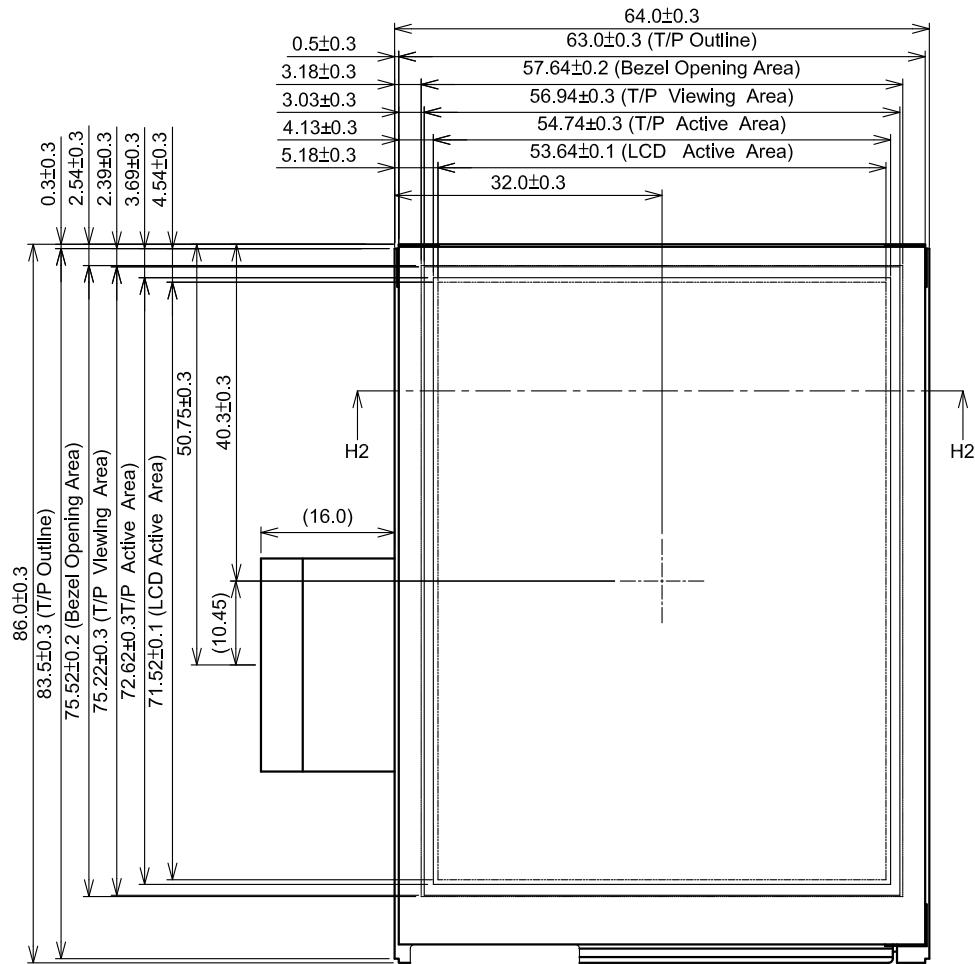

Detail C

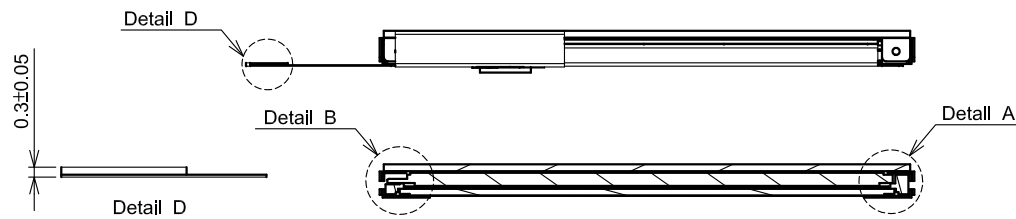
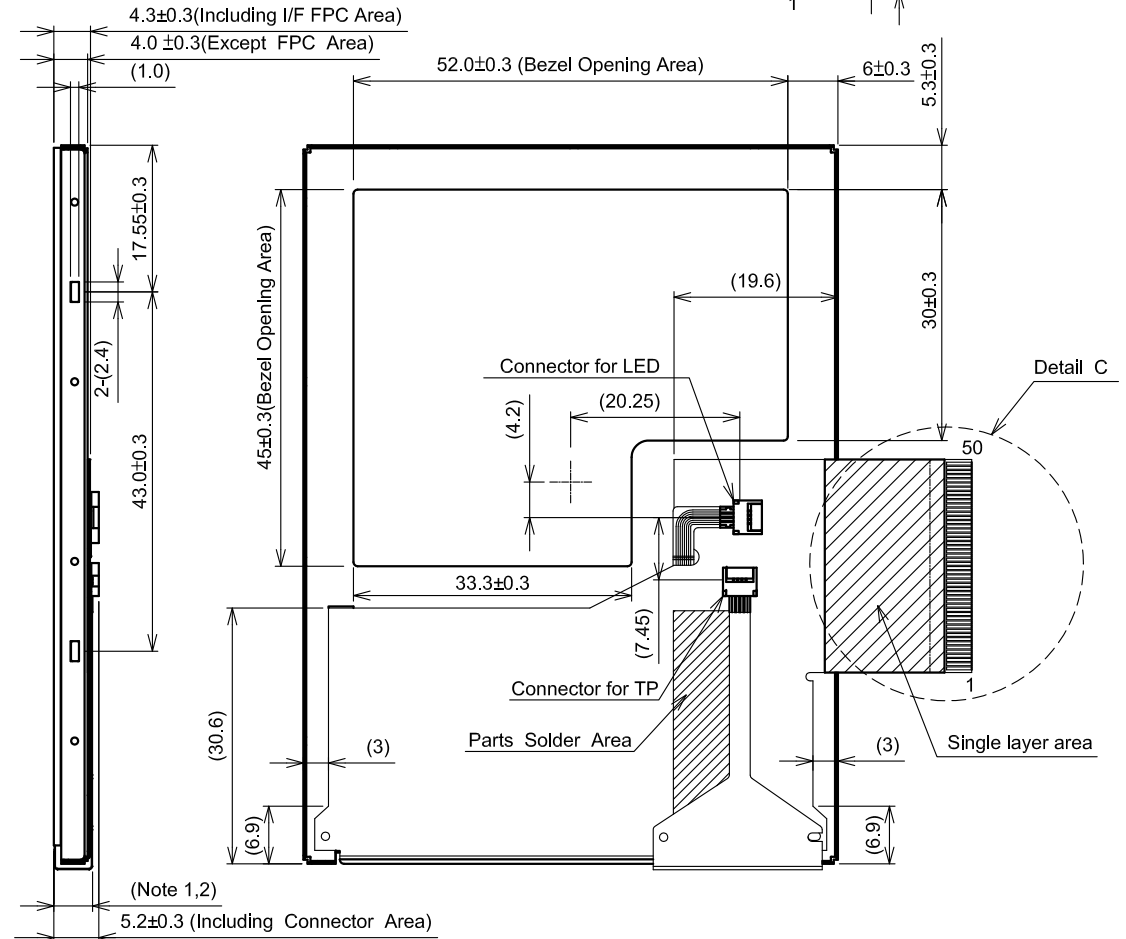
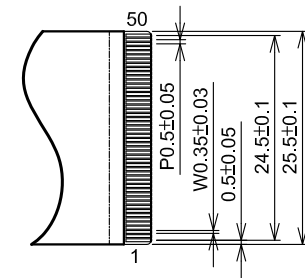

SECTION H2-H2

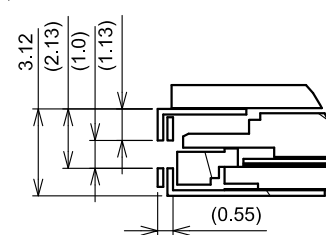

Detail B

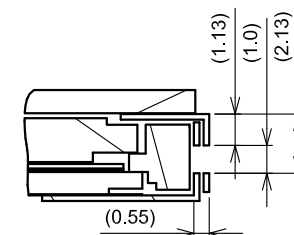

Detail A

Note 1: This thickness including T/P FPC is 5.1max before 6035T and 5.0max after 6041T.
 Note 2: The measure pressure must be above 1N.

Scale : NTS
 Unit : mm

10. APPEARANCE STANDARD

10.1 APPEARANCE INSPECTION CONDITION

Visual inspection should be done under the following condition.

- (1) The inspection should be done in a dark room.(More than 1000(lx) and non-directive)
- (2) The distance between eyes of an inspector and the LCD module is 30cm.
- (3) The viewing zone is shown the figure.

Viewing angle $\leq 25^\circ$

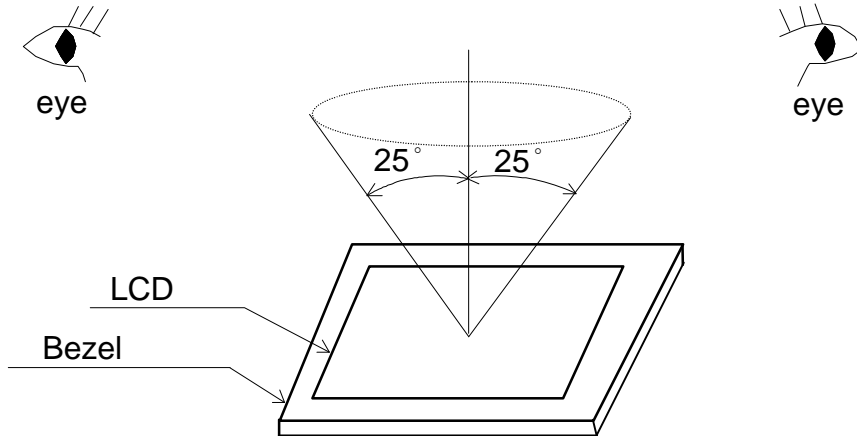

10.2 DEFINITION OF ZONE

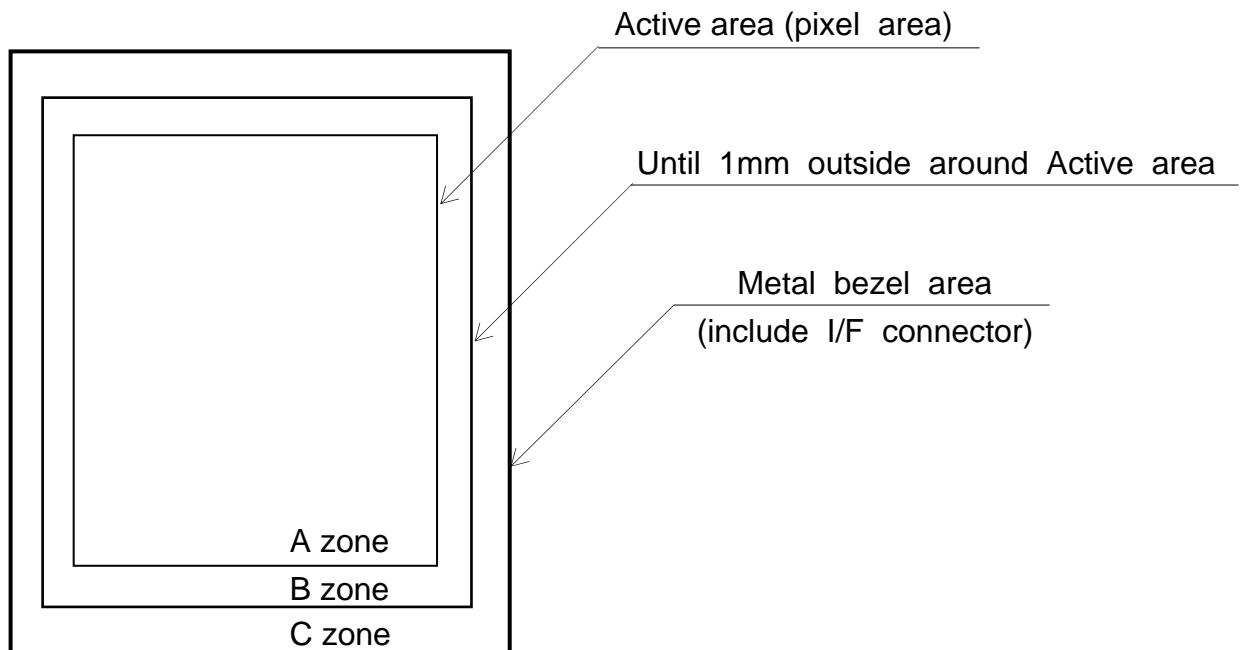

10.3 APPEARANCE SPECIFICATION

(1)LCD Appearance

*) If the problem related to this section occurs about this item, the responsible persons of both party (Customer and HITACHI) will discuss the matter in detail.

No.	ITEM	CRITERIA			APPLIED ZONE
L C D	Scratches	Length L(mm)	Width W(mm)	Maximum number acceptable	A,B
		$L \leq 2.0$	$W \leq 0.03$	ignored	
		$L \leq 2.0$	$0.03 < W \leq 0.05$	4	
		$L > 2.0$	$0.05 < W$	none	
	Dent	Distinguished one is acceptable (To be judged by HITACHI standard)			A
	Wrinkles in Polarizer	Same as above			A
	Bubbles	Average diameter D(mm)		Maximum number acceptable	A
		$D \leq 0.3$		2	
		$0.3 < D$		none	
	Stains Foreign Materials	Filamentous (Line shape)			A,B
		Length L(mm)	Width W(mm)	Maximum number acceptable	
	Dark spot	$L < 2.0$	$W \leq 0.05$	4	
		$L \leq 1.0$	$0.05 < W \leq 0.1$	2	
		Round(Dot shape)			A,B
		Average diameter D(mm)		Maximum number acceptable	
		$D \leq 0.15$		6	
		$0.15 < D \leq 0.2$		4	
		$0.2 < D$		none	
		The total number		Filamentous + Round=9	
	Those wiped out easily are acceptable				
Color Tone	To be judged by HITACHI STANDARD			A	
Color Uniformity	Same as above			A	
Dot Defect			Maximum number acceptable	A , B	
	Sparkle mode	1 dot	4		
		2 dots	2(sets)		
		Total	4		
	Black mode	1 dot	4		
		2 dots	2(sets)		
		Total	4		
Sparkle mode & Black mode	2 dots	2(sets)			
Total	6				

(2) Touch panel appearance

Visual inspection should be done under the following condition.

*) The inspection should be done in a dark room. (more than 500 lx) and non-directive)

*) The distance between eyes of an inspector and the LCD module is 30 cm.

*) The viewing angle $\leq 60^\circ$.

No.	ITEM	CRITERIA			APPLIED ZONE
T O U C H P A N E L	Scratches	Length L(mm)	Width W(mm)	Maximum number acceptable	A,B
		-	$W < 0.05$	ignored	
		$10 < L$	$0.05 \leq W < 0.1$	none	
		-	$0.1 \leq W$	none	
	Foreign Materials Dark Spot	Filamentous (Line shape)			A,B
		Length L(mm)	Width W(mm)	Maximum number acceptable	
		-	$W < 0.05$	Ignored	
		$L > 3$	$0.05 \leq W \leq 0.1$	none	
		-	$W \geq 0.1$	Round	
		Round(Dot shape)			A,B
		Average diameter D(mm)		Maximum number acceptable	
		$D \leq 0.25$		ignored	
		$0.25 < D \leq 0.35$		6	
		$0.35 < D$		none	A,B
	Newton Ring (Touch Panel)	To be judged by HITACHI standard			A,B
Touch Panel Uncleanness	No conspicuous dirt			A	
Rubbing Scratch	To be judged by HITACHI standard			-	

(3) Glass indentation

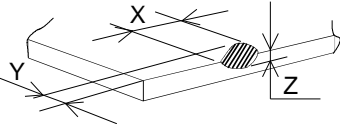
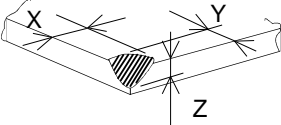
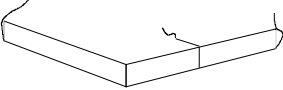
ITEM	SPECIFICATIONS						
Common Indentation	 <table border="1" style="display: inline-table; vertical-align: middle;"> <tr> <td>X</td> <td>Y</td> <td>Z</td> </tr> <tr> <td>≤ 5.0</td> <td>≤ 3.0</td> <td>$\leq t$</td> </tr> </table>	X	Y	Z	≤ 5.0	≤ 3.0	$\leq t$
X	Y	Z					
≤ 5.0	≤ 3.0	$\leq t$					
Corner Broken	 <table border="1" style="display: inline-table; vertical-align: middle;"> <tr> <td>X</td> <td>Y</td> <td>Z</td> </tr> <tr> <td>≤ 3.0</td> <td>≤ 3.0</td> <td>$\leq t$</td> </tr> </table>	X	Y	Z	≤ 3.0	≤ 3.0	$\leq t$
X	Y	Z					
≤ 3.0	≤ 3.0	$\leq t$					
Proceeding Crack	 <p style="text-align: center;">None</p>						

Note 1 : Definition of average diameter (D)

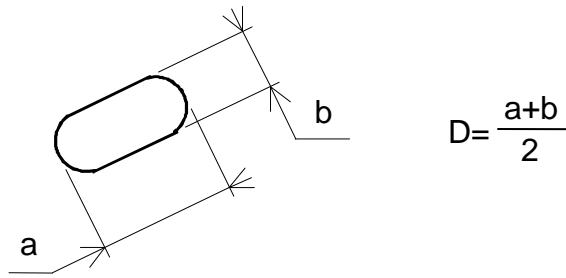

Note 2 : Definition of length (L) and width (W)

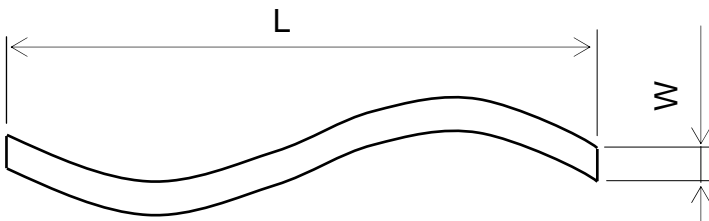

Note 3 : Definition of dot defect

- (a) Dot Defect : Defect Area > 1/2 dot
- (b) Sparkle mode : Brightness of dot is more than 30% at Black raster.
- (c) Black mode : Brightness of dot is less than 70% at R.G.B raster.
- (d) 1 dot : Defect dot is isolated , not attached to other defect dot.
- (e) N dot : N defect dots are consecutive .

(N means the number of defect dots.)

R	G	B	R	G	B	R	G	B
				X				

2 dots defect included defect dot "X" is defined as follows.

Adjacent dots to defect dot "X" :



- (f) Counting definition of adjacent dots(1 sets) : same as 1 dot defect.
- (g) Those wiped out easily are acceptable

11. PRECAUTION IN DESIGN

11.1 MOUNTING PRECAUTION

(1) When assembling the Touch Panel and you case, please refer to the figure below.

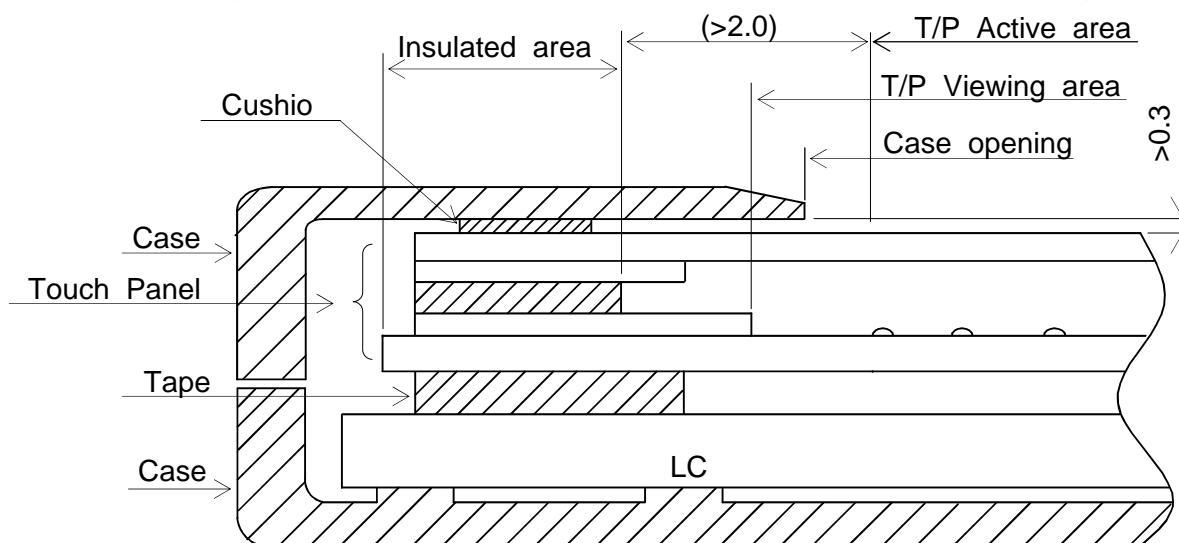

- (2) The clearance between the Touch Panel and case shall be designed so that the case edge never presses the input screen when it is deformed by heat or other causes.
- (3) The case shall be designed not to touch the tail portion (FPC for Touch Panel).
- (4) The boundary space between the effective area and the insulated area is unstable. Touching this area may effect the operation of the Touch Panel. The case must be designed so that it does not touch the boundary space.

11.2 PRECAUTIONS AGAINST ELECTROSTATIC DISCHARGE

As this module contains C-MOS LSIs, it is not strong against electrostatic discharge. Make certain that the operator's body is connected to the ground through a list band, etc. And don't touch I/F pins directly.

11.3 HANDLING PRECAUTIONS

- (1) Since the Touch Panel on the top, and the frame on the bottom tend to be easily damaged, they should be with full care so as not to get them touched, pushed or rubbed by a piece on glass, tweezers and anything else which are harder a pencil lead 3H.

- (2) As the adhesives used for adhering upper/lower polarizer's and frame are made of organic substances which will be deteriorated by a chemical reaction with such chemicals as acetone, toluene, ethanol and isopropyl alcohol. The following are recommended for use :
normal hexane

Please contact with us when it is necessary for you to use chemicals other than the above.

- (3) Lightly wipe to clean the dirty surface with absorbent cotton or other soft material like chamois, soaked in the recommended chemicals without scrubbing it hardly.
Always wipe the surface horizontally or vertically. Never give a wipe in a circle. To prevent the display surface from damage and keep the appearance in good state, it is sufficient, in general, to wipe it with absorbent cotton.
- (4) Immediately wipe off saliva or water drop attached on the display area because it may cause deformation or faded color.
- (5) Foggy dew deposited on the surface may cause a damage, stain or dirt to the polarizer.
When you need to take out the LCD module from some place at low temperature for test, etc.
It is required to be warmed them up to temperature higher than room temperature before taking them out.
- (6) Touching the display area or I/F pins with bare hands or contaminating them are prohibited, because the stain on the display area and poor insulation between terminals are often caused by being touched with bare hands.
(Some cosmetics are detrimental to polarizer's.)
- (7) In general, the glass is fragile so that, especially on its periphery, tends to be cracked or chipped in handling. Please not give the LCD module sharp shocks by falling , etc.
- (8) Maximum pressure to the surface must be less than 1.96×10^4 Pa.
And if the pressure area is less than 1cm^2 , maximum pressure must be less than 1.96N.
- (9) Since the metal width is narrow on these locations (see page 9-1/1), please careful with handling.
- (10) Top sheets shall be cleaned gently using a soft cloth such as those used for glasses.
Hard wiping accumulated dust will leave scars on the surface even using a cloth.

11.4 OPERATION PRECAUTION

- (1) Using a LCM module beyond its maximum ratings may result in its permanent destruction.
LCM module's should usually be used under recommended operating conditions shown in chapter 4 and chapter 5. Exceeding any of these conditions may adversely affect its reliability.

KAOHSIUNG HITACHI ELECTRONICS CO.,LTD.	DATE	Jan.14,'11	Sh. No.	7B64PS 2711-TX09D40VM3CAA-3	PAGE	11-2/3
---	------	------------	------------	-----------------------------	------	--------

- (2) Response time will be extremely delayed at lower temperature than the specified operating temperature range and on the other hand LCD's shows dark blue at higher temperature.
However those phenomena do not main defects of the LCD module. Those phenomena will disappear in the specified operating temperature range.
- (3) If the display area is pushed hard during operation, some display patterns will be abnormally display.
- (4) A slight dew depositing on terminals may cause electrochemical reaction which leads to terminal open circuit. Please operate the LCD module under the relative condition of 40°C 85%RH.
- (5) Resistance range : Your controller shall be set up to allow the resistance range of Touch Panel specified in our CAS.
- (6) Pointed position of Touch Panel may shift owing to a change in resistance of Touch Panel depending on the operation condition . To compensate this shift, the set shall be given a calibration function.
- (7) Input shall be made with a stylus pen (polyacetal , R0.8). Chances are very high that use of a metal piece including a ball point pen or sharp edge will impair accuracy.
- (8) The Touch Panel is an auxiliary input device. The system shall be designed to have other input device.

11.5 STORAGE

In case of storing LCD module for a long period of time (for instance, for years) for the purpose of replacement use, the following precautions necessary.

- (1) Store the LCD modules in a dark place; do not expose them to sunlight or ultraviolet rays.
- (2) Keep the temperature between -30°C and 80°C at normal humidity.
- (3) Store the LCD modules in the container which is used for shipping from us.
- (4) No articles shall be left on the surface over an extended period of time.

11.6 SAFETY

Wear finger cots or gloves whenever handling or assembling a Touch Panel its glass edges are sharp.

12. DESIGNATION OF LOT MARK

12.1 LOT MARK

Lot mark is consisted of 4 digits for production lot 6 digits for production control..

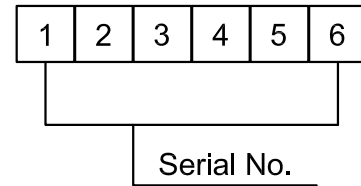
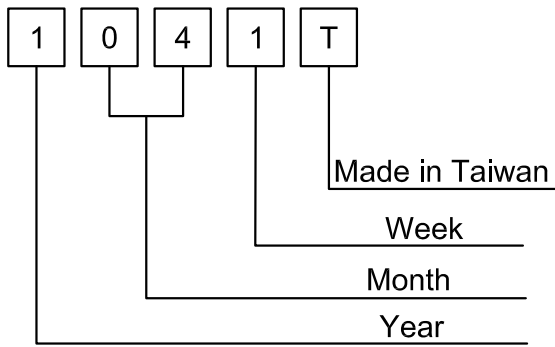

Year	Mark
2011	1
2012	1
2013	3
2014	4
2015	5

Month	Jan.	Feb.	Mar.	Apr.	May	Jun.
Mark	01	02	03	04	05	06
Month	Jul.	Aug.	Sep.	Oct.	Nov.	Dec.
Mark	07	08	09	10	11	12

Week (Day In Calendar)	Figure In Lot Mark
01~07	1
08~14	2
15~21	3
22~28	4
29~31	5

12.2 REVISION (REV.) CONTROL

Rev. is the column for manufacturing convenience A-Z except I and O maybe written on this column.

REV.No	ITEM	NOTE
A	-	-
B	Connectors Changed	PCN0804

12.3 Location of lot mark : On the FPC

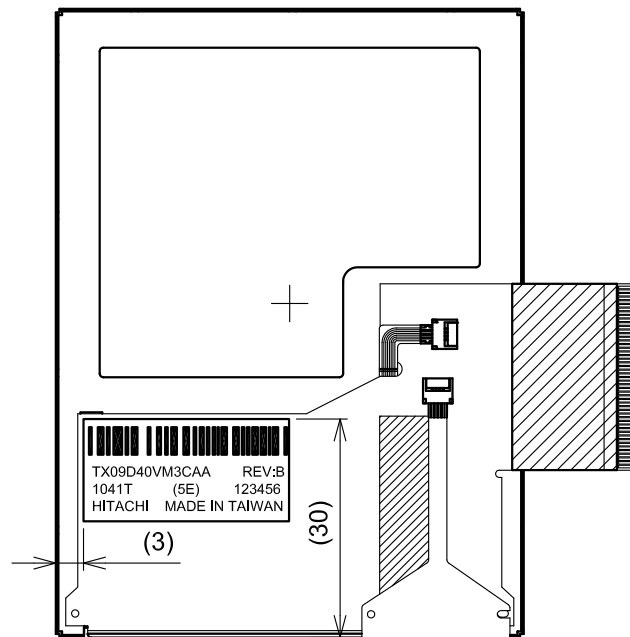

13. PRECAUTION FOR USE

(1) A limit sample should be provided by the both parties on an occasion when the both parties agree to its necessity.

Judgement by a limit sample shall take effect after the limit sample has been established and confirmed by the both parties.

(2) On the following occasions, the handling of the problem should be decided through discussion and agreement between responsible persons of the both parties.

1) When a question is arisen in the specifications.

2) When a new problem is arisen which is not specified in this specifications.

3) When an inspection specifications change or operating condition change by customer is reported to HITACHI, and some problem is arisen in the specification due to the change.

4) When a new problem is arisen at the customer's operating set for sample evaluation.

(3) Regarding the treatment for maintenance and repairing, both parties will discuss it in six months later after latest delivery of this product.

The precaution that should be observed when handling LCM have been explained above.

If any points are unclear or if you have any requests , please contact with HITACHI.