

S29AL008D Known Good Die

8 Megabit (1 M x 8-Bit/512 K x 16-Bit)
CMOS 3.0 Volt-only, Boot Sector Flash Memory



Supplement

Distinctive Characteristics

- **Single power supply operation**
 - 2.7V to 3.6V for read, program, and erase operations
- **Manufactured on 0.20µm process technology**
- **High performance**
 - Access times as fast as 70 ns
- **Ultra low power consumption (typical values at 5 MHz)**
 - 200 nA Automatic Sleep mode current
 - 200 nA standby mode current
 - 7 mA read current
 - 15 mA program/erase current
- **Flexible sector architecture**
 - One 16 Kbyte, two 8 Kbyte, one 32 Kbyte, and fifteen 64 Kbyte sectors (byte mode)
 - One 8 Kword, two 4 Kword, one 16 Kword, and fifteen 32 Kword sectors (word mode)
 - Supports full chip erase
 - Sector Protection features:
 - A hardware method of locking a sector to prevent any program or erase operations within that sector
 - Sectors can be locked in-system or via programming equipment
 - Temporary Sector Unprotect feature allows code changes in previously locked sectors
- **Unlock Bypass Program Command**
 - Reduces overall programming time when issuing multiple program command sequences
- **Top or bottom boot block configurations available**
- **Embedded Algorithms**
 - Embedded Erase algorithm automatically preprograms and erases the entire chip or any combination of designated sectors
 - Embedded Program algorithm automatically writes and verifies data at specified addresses
- **Minimum one million write cycle guarantee per sector**
- **Compatibility with JEDEC standards**
 - Pinout and software compatible with single-power supply Flash
 - Superior inadvertent write protection
- **Data# Polling and toggle bits**
 - Provides a software method of detecting program or erase operation completion
- **Ready/Busy# pin (RY/BY#)**
 - Provides a hardware method of detecting program or erase cycle completion
- **Erase Suspend/Erase Resume**
 - Suspends an erase operation to read data from, or program data to, a sector that is not being erased, then resumes the erase operation
- **Hardware reset pin (RESET#)**
 - Hardware method to reset the device to reading array data
- **20-year data retention at 125°C**
 - Reliable operation for the life of the system
- **Tested to data sheet specifications at temperature**
- **Quality and reliability levels equivalent to standard packaged components**

1. General Description

The S29AL008D in Known Good Die (KGD) form is an 8 Mbit, 3.0 volt-only Flash memory. Spansion defines KGD as standard product in die form, tested for functionality and speed. Spansion KGD products have the same reliability and quality as Spansion products in packaged form.

1.1 S29AL008D Features

The S29AL008D is an 8 Mbit, 3.0 volt-only Flash memory organized as 1,048,576 bytes or 524,288 words. The word-wide data (x16) appears on DQ15–DQ0; the byte-wide (x8) data appears on DQ7–DQ0. To eliminate bus contention, the device has separate chip enable (CE#), write enable (WE#) and output enable (OE#) controls.

The device requires only a **single 3.0 volt power supply** for both read and write functions. Internally generated and regulated voltages are provided for the program and erase operations. No V_{PP} is required for program or erase operations. The device can also be programmed in standard EPROM programmers.

The device is entirely command set compatible with the **JEDEC single-power-supply Flash standard**. Commands are written to the command register using standard microprocessor write timings. Register contents serve as input to an internal state-machine that controls the erase and programming circuitry. Write cycles also internally latch addresses and data needed for the programming and erase operations. Reading data out of the device is similar to reading from other Flash or EPROM devices.

Device programming occurs by executing the program command sequence. This initiates the **Embedded Program** algorithm—an internal algorithm that automatically times the program pulse widths and verifies proper cell margin. The **Unlock Bypass** mode facilitates faster programming times by requiring only two write cycles to program data instead of four.

Device erasure occurs by executing the erase command sequence. This initiates the **Embedded Erase** algorithm—an internal algorithm that automatically preprograms the array (if it is not already programmed) before executing the erase operation. During erase, the device automatically times the erase pulse widths and verifies proper cell margin.

The host system can detect whether a program or erase operation is complete by observing the RY/BY# pin, or by reading the DQ7 (Data# Polling) and DQ6 (toggle) **status bits**. After a program or erase cycle is completed, the device is ready to read array data or accept another command.

The **sector erase architecture** allows memory sectors to be erased and reprogrammed without affecting the data contents of other sectors. The device is fully erased when shipped from the factory.

Hardware data protection measures include a low V_{CC} detector that automatically inhibits write operations during power transitions. The **hardware sector protection** feature disables both program and erase operations in any combination of the sectors of memory. This can be achieved in-system or via programming equipment.

The **Erase Suspend** feature enables the user to put erase on hold for any period of time to read data from, or program data to, any sector that is not selected for erasure. True background erase can thus be achieved.

The **hardware RESET# pin** terminates any operation in progress and resets the internal state machine to reading array data. The RESET# pin may be tied to the system reset circuitry. A system reset would thus also reset the device, enabling the system microprocessor to read the boot-up firmware from the Flash memory.

The device offers two power-saving features. When addresses are stable for a specified amount of time, the device enters the **automatic sleep mode**. The system can also place the device into the **standby mode**. Power consumption is greatly reduced in both these modes.

Spansion's Flash technology combines years of Flash memory manufacturing experience to produce the highest levels of quality, reliability and cost effectiveness. The device electrically erases all bits within a sector simultaneously via Fowler-Nordheim tunneling. The data is programmed using hot electron injection.

1.2 Electrical Specifications

Refer to the S29AL008D data sheet, publication number S29AL008D_00, for full electrical specifications on the S29AL008D in KGD form.

4. Pad Description

Table 4.1 Pads Relative to Die Center

Pad No.	Signal	Pad Center (mils)		Pad Center (millimeters)	
		X	Y	X	Y
1	A15	71.110	52.729	1.806	1.339
2	A14	66.008	52.729	1.677	1.339
3	A13	60.905	52.729	1.547	1.339
4	A12	55.803	52.729	1.417	1.339
5	A11	50.700	52.729	1.288	1.339
6	A10	45.598	52.729	1.158	1.339
7	A9	40.496	52.729	1.029	1.339
8	A8	35.393	52.729	0.899	1.339
9	WE#	25.189	52.729	0.640	1.339
10	RESET#	20.086	52.729	0.510	1.339
11	RY/BY#	-19.245	52.729	-0.489	1.339
12	A18	-29.450	52.729	-0.748	1.339
13	A17	-34.553	52.729	-0.878	1.339
14	A7	-39.655	52.729	-1.007	1.339
15	A6	-44.757	52.729	-1.137	1.339
16	A5	-49.860	52.729	-1.266	1.339
17	A4	-54.962	52.729	-1.396	1.339
18	A3	-60.064	52.729	-1.526	1.339
19	A2	-65.167	52.729	-1.655	1.339
20	A1	-70.269	52.729	-1.785	1.339
21	A0	-70.467	-52.707	-1.790	-1.339
22	CE#	-65.365	-52.707	-1.660	-1.339
23	VSS	-60.261	-52.707	-1.531	-1.339
24	OE#	-51.071	-52.707	-1.297	-1.339
25	DQ0	-44.610	-52.502	-1.133	-1.334
26	DQ8	-39.196	-52.502	-0.996	-1.334
27	DQ1	-33.792	-52.502	-0.858	-1.334
28	DQ9	-28.378	-52.502	-0.721	-1.334
29	DQ2	-22.965	-52.502	-0.583	-1.334
30	DQ10	-17.551	-52.502	-0.446	-1.334
31	DQ3	-12.146	-52.502	-0.309	-1.334
32	DQ11	-6.732	-52.502	-0.171	-1.334
33	VCC	0.649	-52.502	0.017	-1.334
34	DQ4	11.644	-52.502	0.296	-1.334
35	DQ12	17.058	-52.502	0.433	-1.334
36	DQ5	22.462	-52.502	0.571	-1.334
37	DQ13	27.876	-52.502	0.708	-1.334
38	DQ6	33.289	-52.502	0.846	-1.334
39	DQ14	38.703	-52.502	0.983	-1.334
40	DQ7	44.108	-52.502	1.120	-1.334
41	DQ15/A-1	49.522	-52.502	1.258	-1.334
42	VSS	59.721	-52.707	1.517	-1.339
43	BYTE#	64.913	-52.707	1.649	-1.339
44	A16	70.016	-52.707	1.778	-1.339

Note

The coordinates above are relative to the die center and can be used to operate wire bonding equipment.

Table 4.2 Pads Relative to V_{CC}

Pad No.	Signal	Pad Center (mils)		Pad Center (millimeters)	
		X	Y	X	Y
1	A15	70.460	105.231	1.790	2.673
2	A14	65.358	105.231	1.660	2.673
3	A13	60.256	105.231	1.531	2.673
4	A12	55.153	105.231	1.401	2.673
5	A11	50.051	105.231	1.271	2.673
6	A10	44.949	105.231	1.142	2.673
7	A9	39.846	105.231	1.012	2.673
8	A8	34.744	105.231	0.883	2.673
9	WE#	24.539	105.231	0.623	2.673
10	RESET#	19.437	105.231	0.494	2.673
11	RY/BY#	-19.895	105.231	-0.505	2.673
12	A18	-30.100	105.231	-0.765	2.673
13	A17	-35.202	105.231	-0.894	2.673
14	A7	-40.304	105.231	-1.024	2.673
15	A6	-45.407	105.231	-1.153	2.673
16	A5	-50.509	105.231	-1.283	2.673
17	A4	-55.612	105.231	-1.413	2.673
18	A3	-60.714	105.231	-1.542	2.673
19	A2	-65.816	105.231	-1.672	2.673
20	A1	-70.919	105.231	-1.801	2.673
21	A0	-71.117	-0.206	-1.806	-0.005
22	CE#	-66.014	-0.206	-1.677	-0.005
23	V _{SS}	-60.910	-0.206	-1.547	-0.005
24	OE#	-51.721	-0.206	-1.314	-0.005
25	DQ0	-45.260	0.000	-1.150	0.000
26	DQ8	-39.846	0.000	-1.012	0.000
27	DQ1	-34.441	0.000	-0.875	0.000
28	DQ9	-29.027	0.000	-0.737	0.000
29	DQ2	-23.614	0.000	-0.600	0.000
30	DQ10	-18.200	0.000	-0.462	0.000
31	DQ3	-12.796	0.000	-0.325	0.000
32	DQ11	-7.381	0.000	-0.187	0.000
33	V _{CC}	0.000	0.000	0.000	0.000
34	DQ4	10.994	0.000	0.279	0.000
35	DQ12	16.408	0.000	0.417	0.000
36	DQ5	21.813	0.000	0.554	0.000
37	DQ13	27.227	0.000	0.692	0.000
38	DQ6	32.640	0.000	0.829	0.000
39	DQ14	38.054	0.000	0.967	0.000
40	DQ7	43.458	0.000	1.104	0.000
41	DQ15/A-1	48.872	0.000	1.241	0.000
42	V _{SS}	59.072	-0.206	1.500	-0.005
43	BYTE#	64.264	-0.206	1.632	-0.005
44	A16	69.367	-0.206	1.762	-0.005

Note

The coordinates above are relative to the center of pad 1 and can be used to operate wire bonding equipment.

5. Ordering Information

5.1 Standard Products

Spansion standard products are available in several packages and operating ranges. The order number (Valid Combination) is formed by a combination of the elements below.

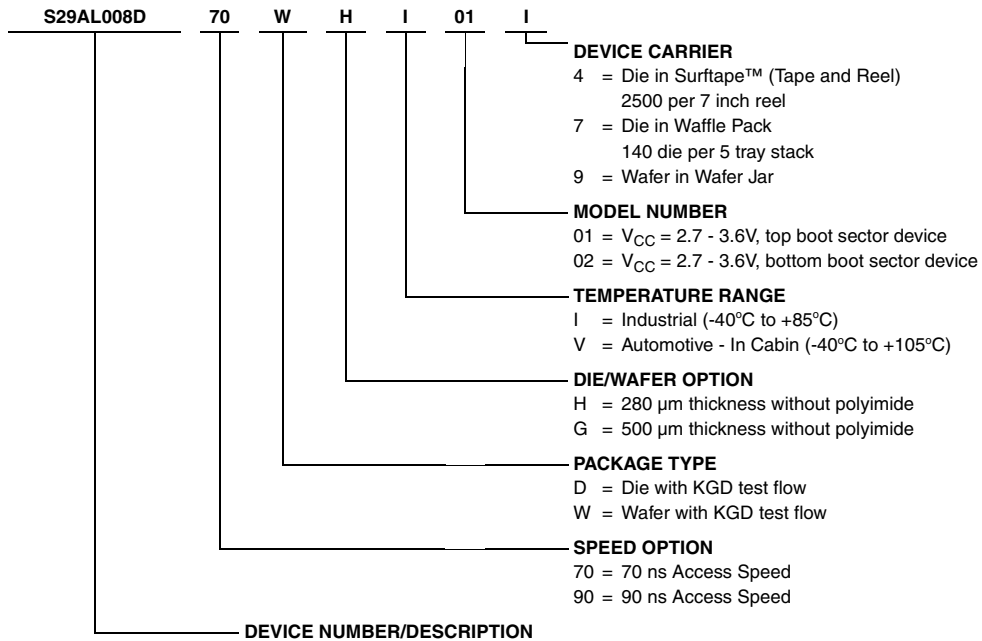

Valid Combinations

Valid Combinations list configurations planned to be supported in volume for this device. Consult the local Spansion sales office to confirm availability of specific valid combinations and to check on newly released combinations.

S29AL008D Valid Combinations				
Device Number	Speed Option	Package Type, and Temperature Range	Model Number	Die Revision
S29AL008D	70, 90	DHI, DGI, DHV, DGV	01, 02	4, 7
		WHI, WGI, WHV, WGV		9

6. Packaging Information

6.1 Surftape Packaging

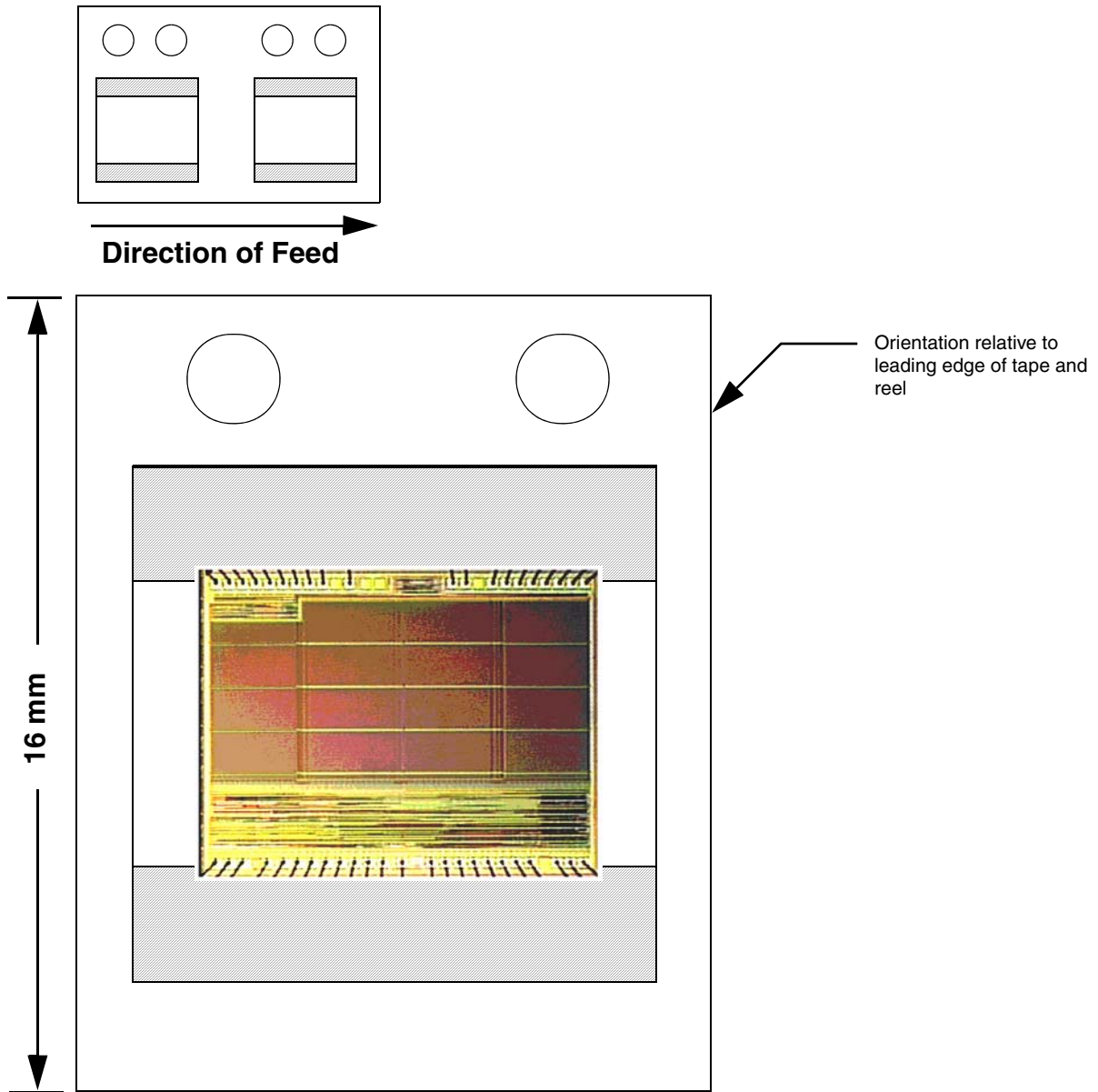

6.2 Waffle Pack Packaging

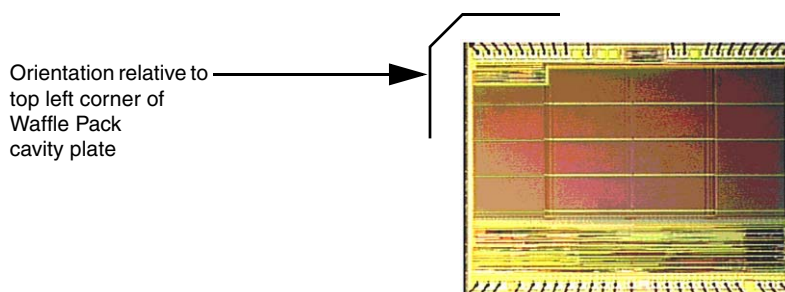

7. Product Test Flow

Figure 7.1 provides an overview of Spansion’s Known Good Die test flow. For more detailed information, refer to the S29AL008D product qualification database supplement for KGD. Spansion implements quality assurance procedures throughout the product test flow. In addition, an off-line quality monitoring program (QMP) further guarantees Spansion quality standards are met on Known Good Die products. These QA procedures also allow Spansion to produce KGD products without requiring or implementing burn-in.

Figure 7.1 Spansion KGD Product Test Flow

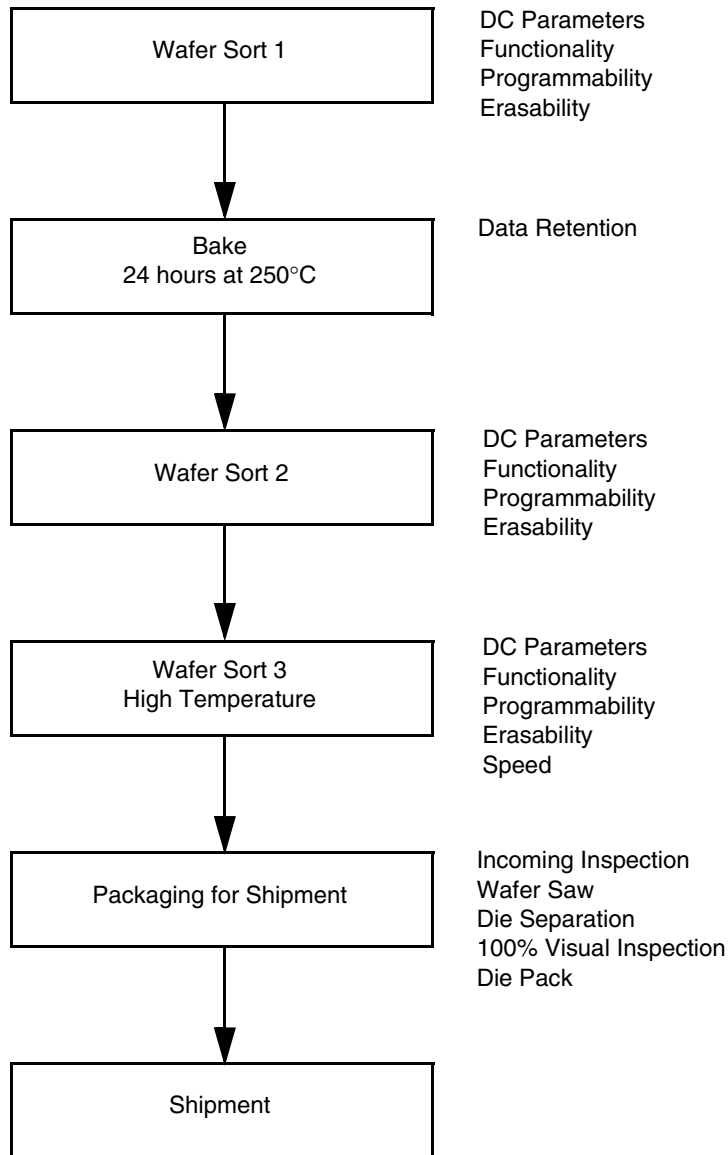

8. Physical Specifications

Die dimensions	153.54 mils X 120.08 mils
.....	3.9 mm x 3.05 mm
Die Thickness	500 μm
Bond Pad Size	3.19 mils x 3.19 mils
.....	81 μm x 81 μm
Pad Area Free of Passivation	10.18 mils ²
.....	6,561 μm^2
Pads Per Die	44
Bond Pad Metalization	Al/Cu
Die Backside	No metal
Passivation.....	Nitride/SOG/Nitride

9. DC Operating Conditions

V _{CC} (Supply Voltage)	2.7 V to 3.6 V
Operating Temperature	
Commercial	0°C to +70°C
Industrial	-40°C to +85°C
Automotive in Cabin	-40°C to +105°C

10. Manufacturing Information

Manufacturing	Spansion
Test	Penang, Malaysia
Manufacturing ID (Top Boot).....	98H19AK
(Bottom Boot).....	98H19ABK
Preparation for Shipment	Penang, Malaysia
Fabrication Process	CS49SS
Die Revision	1

11. Special Handling Instructions

11.1 Processing

Do not expose KGD products to ultraviolet light or process them at temperatures greater than 250°C. Failure to adhere to these handling instructions will result in irreparable damage to the devices. For best yield, Spansion recommends assembly in a Class 10K clean room with 30% to 60% relative humidity.

11.2 Storage

Store at a maximum temperature of 30°C in a nitrogen-purged cabinet or vacuum-sealed bag. Observe all standard ESD handling procedures.

12. Terms and Conditions of Sale for Spansion Non-Volatile Memory Die

All transactions relating to unpackaged die under this agreement shall be subject to Spansion's standard terms and conditions of sale, or any revisions thereof, which revisions Spansion reserves the right to make at any time and from time to time. In the event of conflict between the provisions of Spansion's standard terms and conditions of sale and this agreement, the terms of this agreement shall be controlling.

Spansion warrants its manufactured unpackaged die whether shipped to customer in individual dice or wafer form ("Known Good Die," "KGD", "Die," "Known Good Wafer", "KGW", or Wafer(s)) will meet Spansion's published specifications and against defective materials or workmanship for a period of one (1) year from date of shipment.

This limited warranty does not extend beyond the first purchaser of said Die or Wafer(s).

Buyer assumes full responsibility to ensure compliance with the appropriate handling, assembly and processing of KGD or KGW (including but not limited to proper Die preparation, Die attach, backgrinding, singulation, wire bonding and related assembly and test activities), and compliance with all guidelines set forth in Spansion's specifications for KGD or KGW, and Spansion assumes no responsibility for environmental effects on KGD or KGW or for any activity of Buyer or a third party that damages the Die or Wafer(s) due to improper use, abuse, negligence, improper installation, improper backgrinding, improper singulation, accident, loss, damage in transit, or unauthorized repair or alteration by a person or entity other than Spansion ("Limited Warranty Exclusions")

The liability of Spansion under this limited warranty is limited, at Spansion's option, solely to repair the Die or Wafer(s), to send replacement Die or Wafer(s), or to make an appropriate credit adjustment or refund in an amount not to exceed the original purchase price actually paid for the Die or Wafer(s) returned to Spansion, provided that: (a) Spansion is promptly notified by Buyer in writing during the applicable warranty period of any defect or nonconformity in the Die or Wafer(s); (b) Buyer obtains authorization from Spansion to return the defective Die or Wafer(s); (c) the defective Die or Wafer(s) is returned to Spansion by Buyer in accordance with Spansion's shipping instructions set forth below; and (d) Buyer shows to Spansion's satisfaction that such alleged defect or nonconformity actually exists and was not caused by any of the above-referenced Warranty Exclusions. Buyer shall ship such defective Die or Wafer(s) to Spansion via Spansion's carrier, collect. Risk of loss will transfer to Spansion when the defective Die or Wafer(s) is provided to Spansion's carrier. If Buyer fails to adhere to these warranty returns guidelines, Buyer shall assume all risk of loss and shall pay for all freight to Spansion's specified location. The aforementioned provisions do not extend the original limited warranty period of any Die or Wafer(s) that has either been replaced by Spansion.

THIS LIMITED WARRANTY IS EXPRESSED IN LIEU OF ALL OTHER WARRANTIES, EXPRESSED OR IMPLIED, INCLUDING THE IMPLIED WARRANTY OF FITNESS FOR A PARTICULAR PURPOSE, THE IMPLIED WARRANTY OF MERCHANTABILITY OR NONINFRINGEMENT AND OF ALL OTHER OBLIGATIONS OR LIABILITIES ON Spansion's PART, AND IT NEITHER ASSUMES NOR AUTHORIZES ANY OTHER PERSON TO ASSUME FOR Spansion ANY OTHER LIABILITIES. THE FOREGOING CONSTITUTES THE BUYER'S SOLE AND EXCLUSIVE REMEDY FOR THE FURNISHING OF DEFECTIVE OR NON CONFORMING KNOWN GOOD DIE OR KNOWN GOOD WAFER(S) AND Spansion SHALL NOT IN ANY EVENT BE LIABLE FOR INCREASED MANUFACTURING COSTS, DOWNTIME COSTS, DAMAGES RELATING TO BUYER'S PROCUREMENT OF SUBSTITUTE DIE OR WAFER(S) (i.e., "COST OF COVER"), LOSS OF PROFITS, REVENUES OR GOODWILL, LOSS OF USE OF OR DAMAGE TO ANY ASSOCIATED EQUIPMENT, OR ANY OTHER INDIRECT, INCIDENTAL, SPECIAL OR CONSEQUENTIAL DAMAGES BY REASON OF THE FACT THAT SUCH KNOWN GOOD DIE OR KNOWN GOOD WAFER(S) SHALL HAVE BEEN DETERMINED TO BE DEFECTIVE OR NON CONFORMING.

Buyer agrees that it will make no warranty representations to its customers which exceed those given by Spansion to Buyer unless and until Buyer shall agree to indemnify Spansion in writing for any claims which exceed Spansion's limited warranty. Known Good Die or Known Good Wafer(s) are not designed or authorized for use as components in life support appliances, devices or systems where malfunction of the Die or Wafer(s) can reasonably be expected to result in a personal injury. Buyer's use of Known Good Die or Known Good Wafer(s) for use in life support applications is at Buyer's own risk and Buyer agrees to fully indemnify Spansion for any damages resulting in such use or sale.

Known Good Die or Known Good Wafer are not designed or authorized for use as components in life support appliances, devices or systems where malfunction of the die or wafer can reasonably be expected to result in a personal injury. Buyer's use of Known Good Die or Known Good Wafer for use in life support applications is at Buyer's own risk and Buyer agrees to fully indemnify Spansion for any damages resulting in such use or sale.

13. Revision History

Section	Description
Revision A (November 23, 2004)	
	Initial release.
Revision A1 (April 29, 2005)	
Die Photograph & Pad Locations	Added pad numbers to drawing
Pad Description	Pads Relative to VCC: Corrected pad number column
Revision A2 (May 19, 2005)	
Ordering Information	Added two types of device carriers, reel and tape; and tray stack Added package type
Valid Combination Table	Added new package type nomenclature
Revision A3 (June 22, 2005)	
Ordering Information	Added Commercial and Industrial values to Temperature Range. Added additional Package Type/Temperature Range values to Valid Combinations tables.
DC Operating Conditions	Repaired temperature settings
Revision A4 (February 9, 2007)	
Manufacturing Information	Changed test location to Penang, Malaysia
Revision A5 (July 17, 2007)	
Ordering Information	Modified Temperature Range options
Valid Combinations Table	Modified Options
Packaging Information	Removed references to Gel-Pak

Colophon

The products described in this document are designed, developed and manufactured as contemplated for general use, including without limitation, ordinary industrial use, general office use, personal use, and household use, but are not designed, developed and manufactured as contemplated (1) for any use that includes fatal risks or dangers that, unless extremely high safety is secured, could have a serious effect to the public, and could lead directly to death, personal injury, severe physical damage or other loss (i.e., nuclear reaction control in nuclear facility, aircraft flight control, air traffic control, mass transport control, medical life support system, missile launch control in weapon system), or (2) for any use where chance of failure is intolerable (i.e., submersible repeater and artificial satellite). Please note that Spansion will not be liable to you and/or any third party for any claims or damages arising in connection with above-mentioned uses of the products. Any semiconductor devices have an inherent chance of failure. You must protect against injury, damage or loss from such failures by incorporating safety design measures into your facility and equipment such as redundancy, fire protection, and prevention of over-current levels and other abnormal operating conditions. If any products described in this document represent goods or technologies subject to certain restrictions on export under the Foreign Exchange and Foreign Trade Law of Japan, the US Export Administration Regulations or the applicable laws of any other country, the prior authorization by the respective government entity will be required for export of those products.

Trademarks and Notice

The contents of this document are subject to change without notice. This document may contain information on a Spansion product under development by Spansion. Spansion reserves the right to change or discontinue work on any product without notice. The information in this document is provided as is without warranty or guarantee of any kind as to its accuracy, completeness, operability, fitness for particular purpose, merchantability, non-infringement of third-party rights, or any other warranty, express, implied, or statutory. Spansion assumes no liability for any damages of any kind arising out of the use of the information in this document.

Copyright © 2004-2007 Spansion Inc. All rights reserved. Spansion®, the Spansion Logo, MirrorBit®, MirrorBit® Eclipse™, ORNAND™, HD-SIM™ and combinations thereof, are trademarks of Spansion LLC in the US and other countries. Other names used are for informational purposes only and may be trademarks of their respective owners.