

DX-200 Series

Digital Dispenser/Controller



QUICK START UP GUIDE

FEATURES

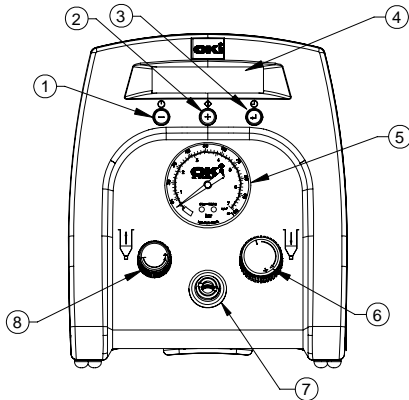

Front View

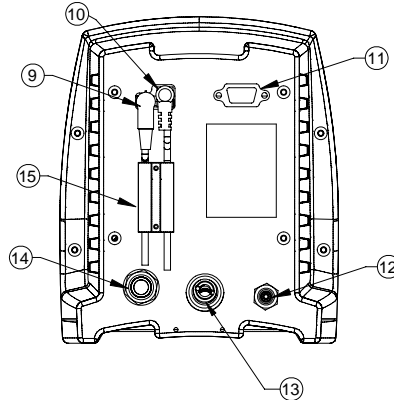

Back View

Items	Description
1	Power Button
2	Mode Button
3	Set up/Save Button
4	Display
5	Air Pressure Gauge
6	Air Pressure Regulator
7	Pulsed Air Outlet
8	Vacuum Control
9	Foot Switch Receptacle
10	Power Receptacle
11	I/O Connection
12	Exhaust Port
13	Constant Air Outlet
14	Air Inlet
15	Cord Lock

CONNECTING THE UNIT

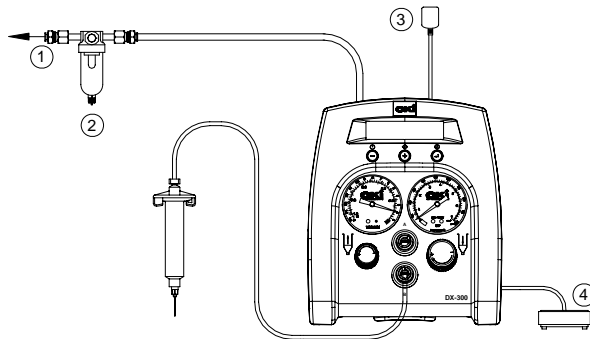

Items	Description
1	To Air Source
2	Air Filter (Not Included)
3	Power Adapter
4	Foot Switch

Installing the Bracket and Air Hose Holder:

1. Align the bracket over the power and Foot switch cord
2. Place the Air Hose Holder in the center of bracket
3. Tighten the two mounting screws



Air Hose Holder

Bracket

Power and Foot Switch Cord

HOW TO SET-UP PURGE DISPENSE CYCLE

1. Press Power Button to turn on unit



2. Press Mode Button to select "PURGE" Mode



3. Rotate Air Pressure Regulator knob clockwise (CW) until desired pressure is indicated on the pressure gauge

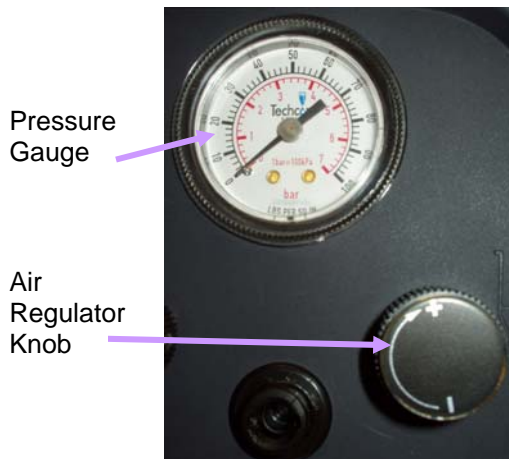

4. Attach Receiver Head Assembly to syringe



5. Connect plug end of Receiver Head Assembly to the control air outlet
If Vacuum "Pull Back" is needed, rotate the vacuum knob counter clockwise

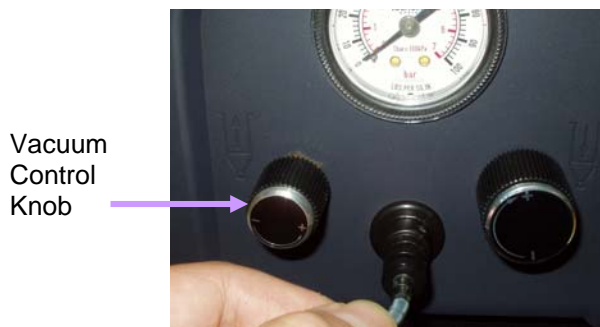

6. Depress Foot Switch to activate dispense cycle



HOW TO SET-UP DISPENSE TIME

1. Push Mode Button to select "CONTINUE" or "INTERRUPT" Mode



2. Press and hold Set Button for two seconds to enter "SETUP" mode.
(The last digit is highlighted with a blinking cursor)



3. Press Set Button to move cursor to next position



4. Press (+) or (-) Activation Button to set dispense time



5. Press and hold Set Button for 2 seconds to save data



6. Depress Foot Switch to activate dispense cycle



HOW TO RESET CYCLE COUNTER

1. Press Set Button to enter "SETUP" mode



2. Press and hold Set Button for 4 seconds to reset counter



OPERATION DIAGRAM

