

Examples of compatible drivers- see website for currently compatible models/ hole centres.

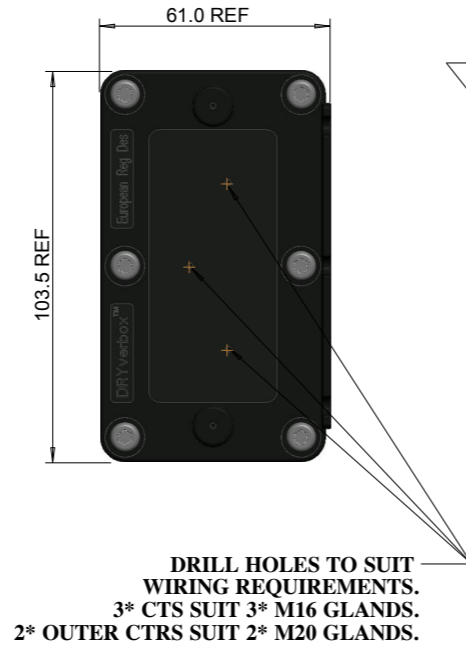
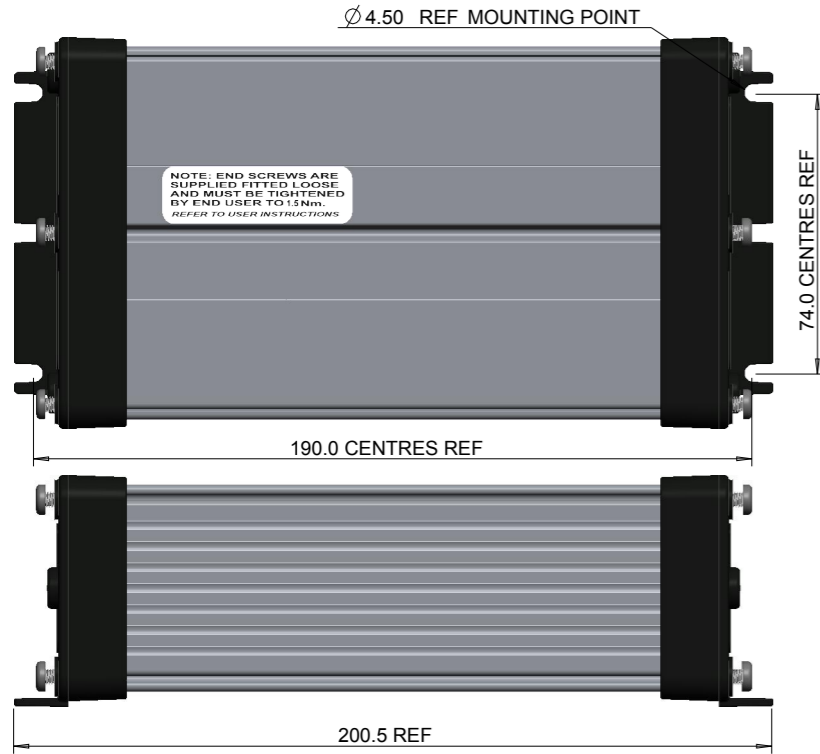

END USER REMOVES THE M4 TORX SCREWS AND CAPS TO INSERT LED DRIVER. -ENSURE ALL END SCREWS ARE FULLY TIGHTENED TO 1.5Nm

INTERNAL M3 EARTHING SCREW

DRIVER MOUNTING PLATE THREADED HOLE MOUNTS FOR LISTED DRIVERS- OTHER COMBINATIONS POSSIBLE. -REQUIRES SCREWS/ NUTS TO FIT REQUIRED DRIVER.

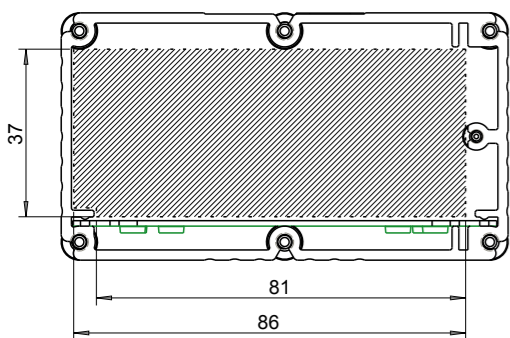
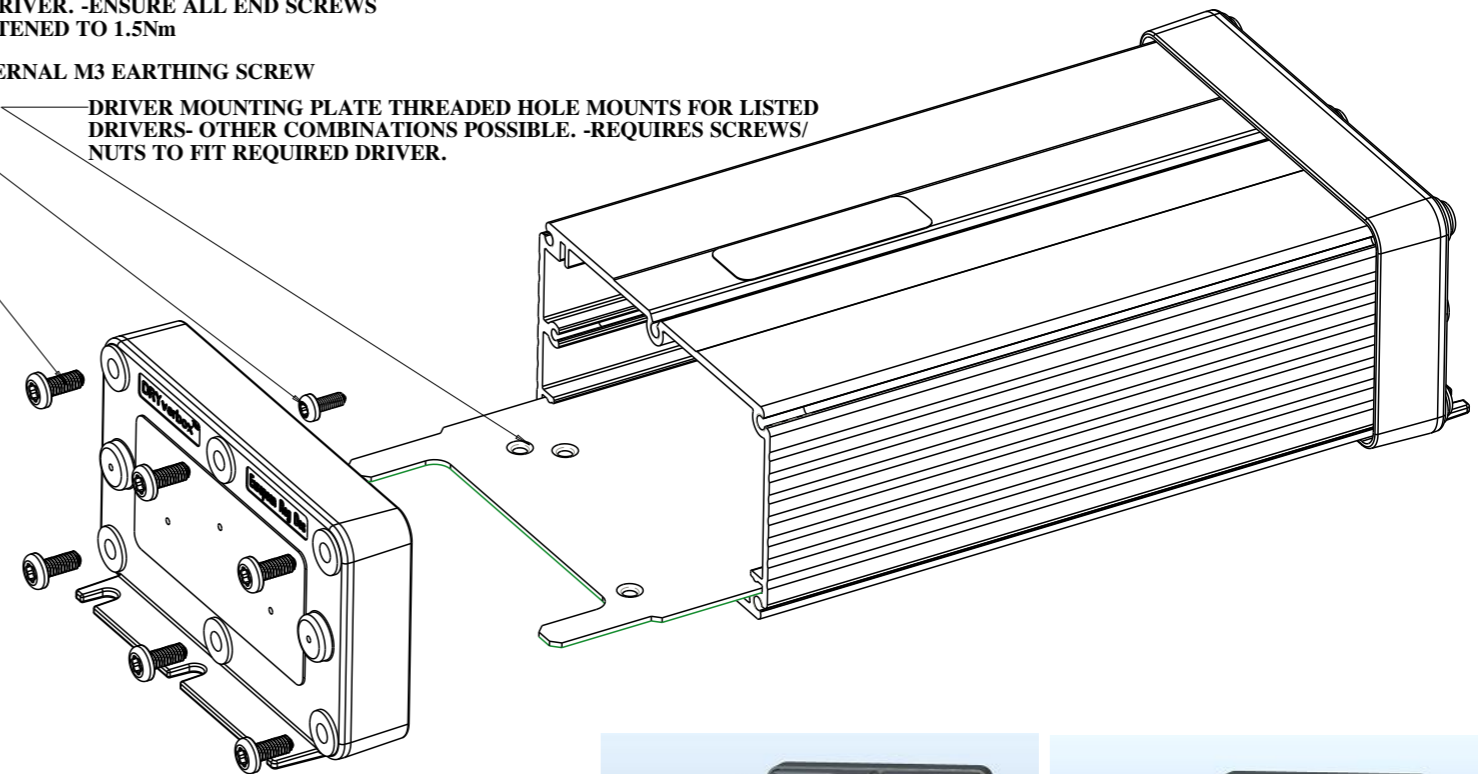

AVAILABLE X-SECTIONAL AREA
* APPROX 140mm LONG
< THIS LENGTH VERSION >.

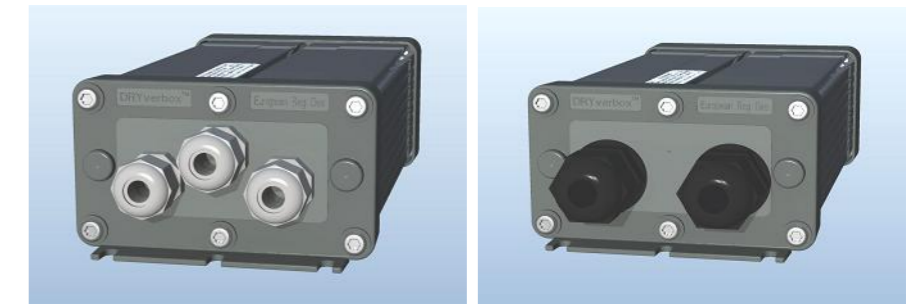
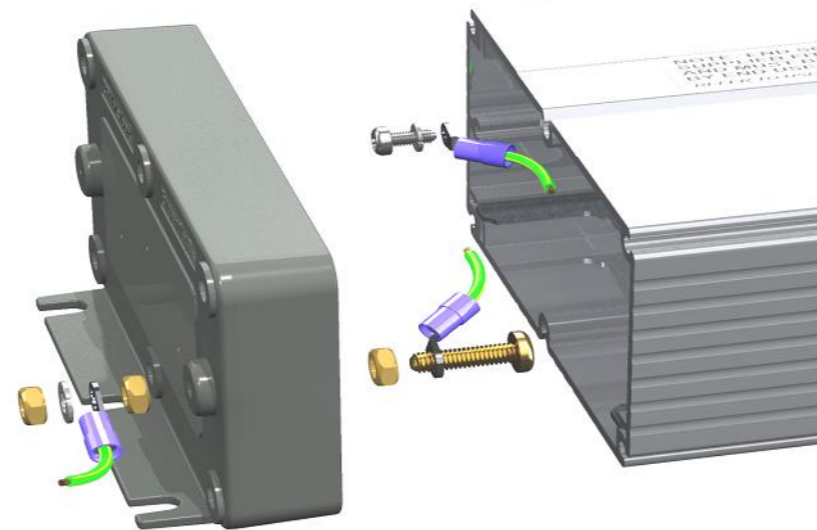

EXAMPLE USING 3* M16 GLANDS

EXAMPLE USING 2* M20 GLANDS

**DRYVERBOX VERSION:
MODEL- 02
LENGTH- 02
WEIGHT 0.54Kg (WITHOUT GLANDS/ DRIVER).
< UNIT SUPPLIED BOXED >**

ALL DIMENSIONS IN mm

DRYVERBOX

ORDER CODE: 107-1002

www.dryverbox.com