

High Luminous Efficacy
Blue LED Emitter

LZ1-00B200



Key Features

- High Luminous Efficacy Blue LED
- Ultra-small foot print – 4.4mm x 4.4mm
- Surface mount ceramic package with integrated glass lens
- Electrically neutral thermal path
- Very high Luminous Flux per area
- New industry standard for Autoclave (135°C, 2 ATM, 100% RH, 168 Hours)
- JEDEC Level 1 for Moisture Sensitivity Level
- Lead (Pb) free and RoHS compliant
- Reflow solderable (up to 6 cycles)
- Available on tape and reel or with MCPCB

Typical Applications

- Indoor and outdoor Architectural Lighting
- Backlighting
- Full Color Displays
- Emergency Lighting
- Signal Lighting

Description

The LZ1-00B200 Blue LED emitter provides 5W power in an extremely small package. With a 4.4mm x 4.4mm ultra-small footprint, this package provides exceptional luminous flux per area, up to 4 times greater than competitors' equivalent products. LED Engin's Blue LED offers ultimate design flexibility with separate electrical and thermal paths. The patent-pending design has unparalleled thermal and optical performance and excellent UV resistance. The high quality materials used in the package are chosen to optimize light output and minimize stresses which results in monumental reliability and lumen maintenance. The robust product design thrives in outdoor applications with high ambient temperatures and high humidity.

Part number options

Base part number

Part number	Description
LZ1-00B200-xxxx	LZ1 emitter
LZ1-10B200-xxxx	LZ1 emitter on Standard Star MCPCB
LZ1-30B200-xxxx	LZ1 emitter on Miniature round MCPCB

Notes:

1. See “Part Number Nomenclature” for full overview on LED Engin part number nomenclature.

Bin kit option codes

B2, Blue (465nm)			
Kit number suffix	Min flux Bin	Color Bin Range	Description
0000	D	B3 – B6	full distribution flux; full distribution wavelength
E000	E	B3 – B6	E min flux bin; full distribution wavelength
0B34	D	B3 – B4	full distribution flux; wavelength B3 and B4 bins
EB34	E	B3 – B4	E min flux; wavelength B3 and B4 bins

Notes:

1. Default bin kit option is -0000

Luminous Flux Bins

Table 1:

Bin Code	Minimum Luminous Flux (Φ_V) @ $I_F = 1000\text{mA}$ ^[1,2] (lm)	Maximum Luminous Flux (Φ_V) @ $I_F = 1000\text{mA}$ ^[1,2] (lm)
D	20	24
E	24	31
F	31	38
G	38	48
H	48	60

Notes for Table 1:

1. Luminous flux performance guaranteed within published operating conditions. LED Engin maintains a tolerance of $\pm 10\%$ on flux measurements.
2. Future products will have even higher levels of luminous flux performance. Contact LED Engin Sales for updated information.

Dominant Wavelength Bins

Table 2:

Bin Code	Minimum Dominant Wavelength (λ_D) @ $I_F = 1000\text{mA}$ ^[1] (nm)	Maximum Dominant Wavelength (λ_D) @ $I_F = 1000\text{mA}$ ^[1] (nm)
B3	450	455
B4	455	460
B5	460	465
B6	465	470

Notes for Table 2:

1. Dominant wavelength is derived from the CIE 1931 Chromaticity Diagram and represents the perceived hue. LED Engin maintains a tolerance of $\pm 1.0\text{nm}$ on dominant wavelength measurements.

Forward Voltage Bins

Table 3:

Bin Code	Minimum Forward Voltage (V_F) @ $I_F = 1000\text{mA}$ ^[1] (V)	Maximum Forward Voltage (V_F) @ $I_F = 1000\text{mA}$ ^[1] (V)
0	3.20	4.40

Notes for Table 3:

1. LED Engin maintains a tolerance of $\pm 0.04\text{V}$ for forward voltage measurements.

Absolute Maximum Ratings

Table 4:

Parameter	Symbol	Value	Unit
DC Forward Current at $T_{jmax}=135^{\circ}\text{C}$ ^[1]	I_F	1200	mA
DC Forward Current at $T_{jmax}=150^{\circ}\text{C}$ ^[1]	I_F	1000	mA
Peak Pulsed Forward Current ^[2]	I_{FP}	2000	mA
Reverse Voltage	V_R	See Note 3	V
Storage Temperature	T_{stg}	-40 ~ +150	°C
Junction Temperature	T_J	150	°C
Soldering Temperature ^[4]	T_{sol}	260	°C
Allowable Reflow Cycles		6	
Autoclave Conditions		135°C at 2 ATM, 100% RH for 168 hours	
ESD Sensitivity ^[5]		> 8,000 V HBM Class 3B JESD22-A114-D	

Notes for Table 4:

- Maximum DC forward current is determined by the overall thermal resistance and ambient temperature. Follow the curves in Figure 10 for current derating.
- Pulse forward current conditions: Pulse Width \leq 10msec and Duty Cycle \leq 10%.
- LEDs are not designed to be reverse biased.
- Solder conditions per JEDEC 020c. See Reflow Soldering Profile Figure 3.
- LED Engin recommends taking reasonable precautions towards possible ESD damages and handling the LZ1-00B205 in an electrostatic protected area (EPA). An EPA may be adequately protected by ESD controls as outlined in ANSI/ESD S6.1.

Optical Characteristics @ $T_C = 25^{\circ}\text{C}$

Table 5:

Parameter	Symbol	Typical	Unit
Luminous Flux (@ $I_F = 1000\text{mA}$)	Φ_V	40	lm
Luminous Flux (@ $I_F = 1200\text{mA}$)	Φ_V	46	lm
Dominant Wavelength	λ_D	460	nm
Viewing Angle ^[1]	$2\theta_{1/2}$	80	Degrees
Total Included Angle ^[2]	$\Theta_{0.9V}$	90	Degrees

Notes for Table 5:

- Viewing Angle is the off axis angle from emitter centerline where the luminous intensity is 1/2 of the peak value.
- Total Included Angle is the total angle that includes 90% of the total luminous flux.

Electrical Characteristics @ $T_C = 25^{\circ}\text{C}$

Table 6:

Parameter	Symbol	Typical	Unit
Forward Voltage (@ $I_F = 1000\text{mA}$)	V_F	3.6	V
Forward Voltage (@ $I_F = 1200\text{mA}$)	V_F	3.7	V
Temperature Coefficient of Forward Voltage	$\Delta V_F/\Delta T_J$	-2.8	mV/°C
Thermal Resistance (Junction to Case)	$R\theta_{J-C}$	9-11	°C/W

IPC/JEDEC Moisture Sensitivity Level

Table 7 - IPC/JEDEC J-STD-20 MSL Classification:

Level	Floor Life		Soak Requirements			
	Time	Conditions	Standard	Accelerated	Time (hrs)	Conditions
1	Unlimited	≤ 30°C/ 85% RH	168 +5/-0	30°C/ 85% RH	n/a	n/a

Notes for Table 7:

1. The standard soak time is the sum of the default value of 24 hours for the semiconductor manufacturer's exposure time (MET) between bake and bag and the floor life of maximum time allowed out of the bag at the end user of distributor's facility.

Average Lumen Maintenance Projections

Lumen maintenance generally describes the ability of a lamp to retain its output over time. The useful lifetime for solid state lighting devices (Power LEDs) is also defined as Lumen Maintenance, with the percentage of the original light output remaining at a defined time period.

Based on long-term WHTOL testing, LED Engin projects that the LZ Series will deliver, on average, 70% Lumen Maintenance at 65,000 hours of operation at a forward current of 1000 mA. This projection is based on constant current operation with junction temperature maintained at or below 125°C.

Mechanical Dimensions (mm)

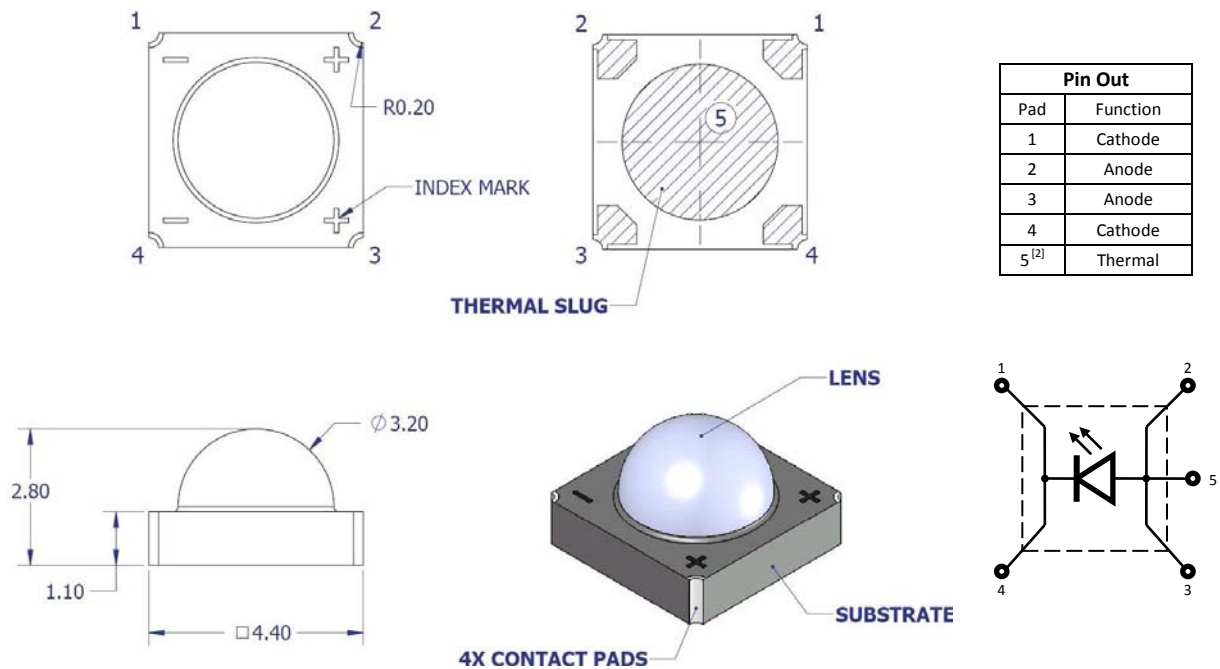

Figure 1: Package outline drawing.

Notes for Figure 1:

- Unless otherwise noted, the tolerance = ± 0.20 mm.
- Thermal contact, Pad 5, is electrically connected to the Anode, Pads 2 and 3. Do not electrically connect any electrical pads to the thermal contact, Pad 5. LED Engin recommends mounting the LZ1-00R100 to a MCPCB that provides insulation between all electrical pads and the thermal contact, Pad 5. LED Engin offers [LZ1-10R100](#) and [LZ1-30R100](#) MCPCB options which provide both electrical and thermal contact insulation with low thermal resistance. Please refer to Application Note MCPCB Options 1 and 3, or contact a LED Engin sales representative for more information.

Recommended Solder Pad Layout (mm)

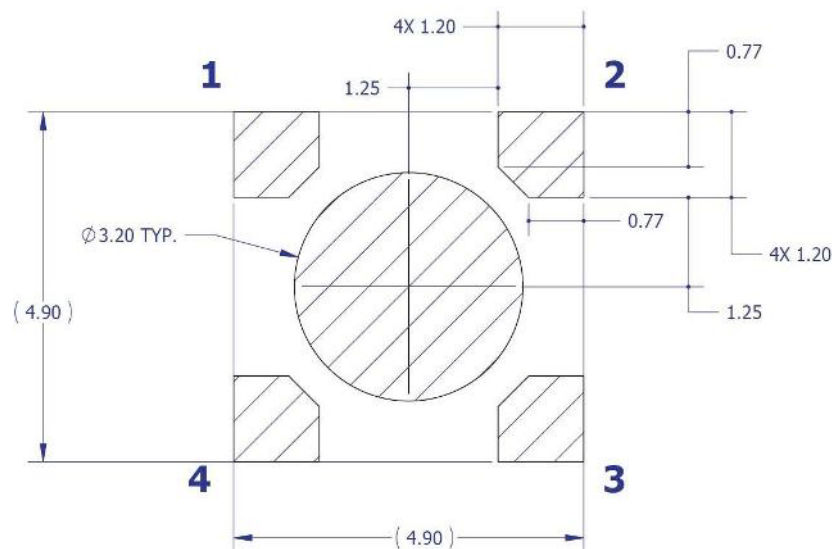

Figure 2: Recommended solder mask opening (hatched area) for anode, cathode, and thermal pad.

Note for Figure 2:

- Unless otherwise noted, the tolerance = ± 0.20 mm.

Reflow Soldering Profile

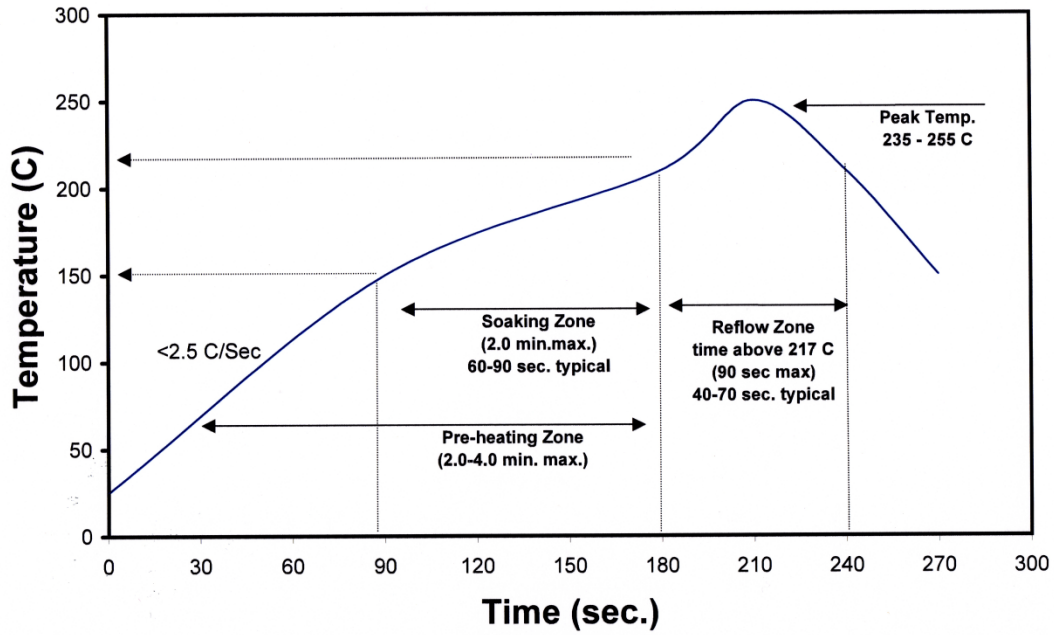

Figure 3: Reflow soldering profile for lead free soldering.

Typical Radiation Pattern

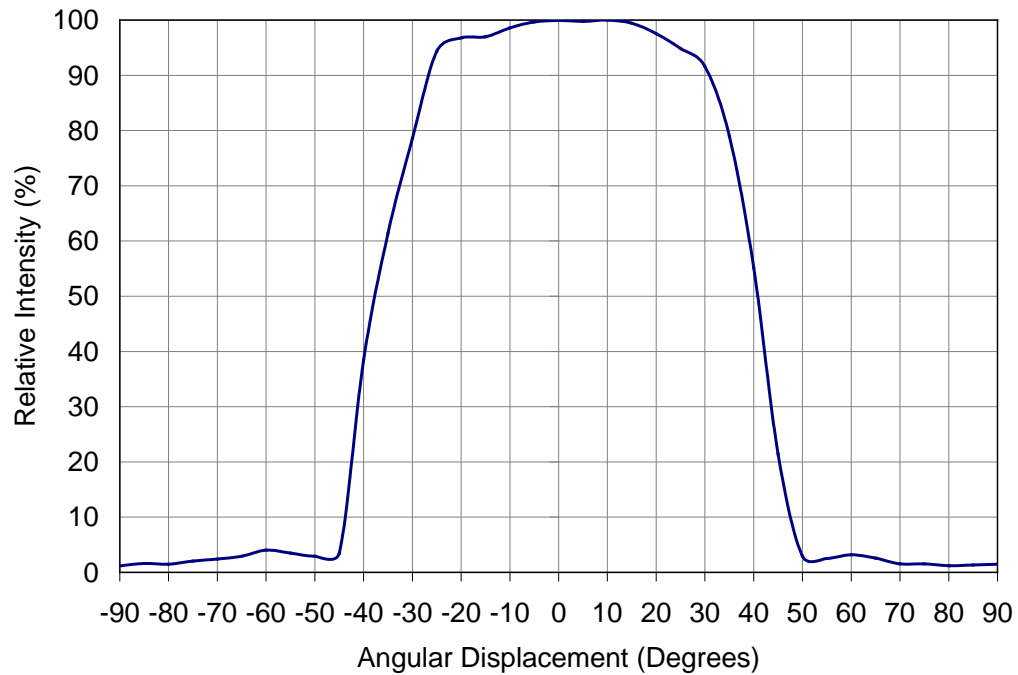

Figure 4: Typical representative spatial radiation pattern @ T_c = 25°C.

Typical Relative Spectral Power Distribution

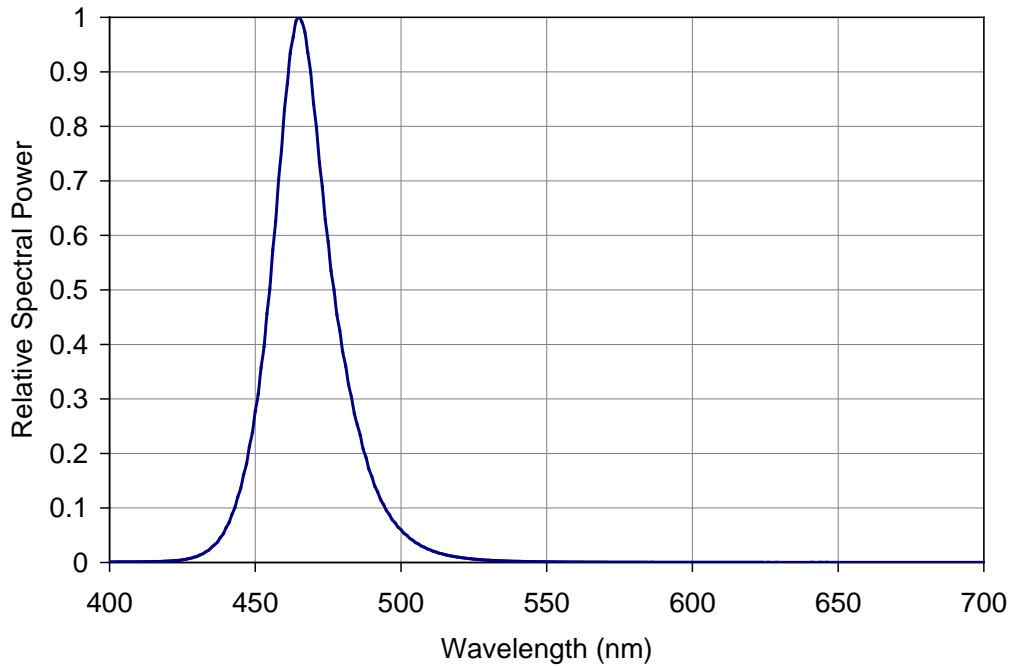

Figure 5: Relative spectral power vs. wavelength @ T_c = 25°C.

Typical Dominant Wavelength Shift over Temperature

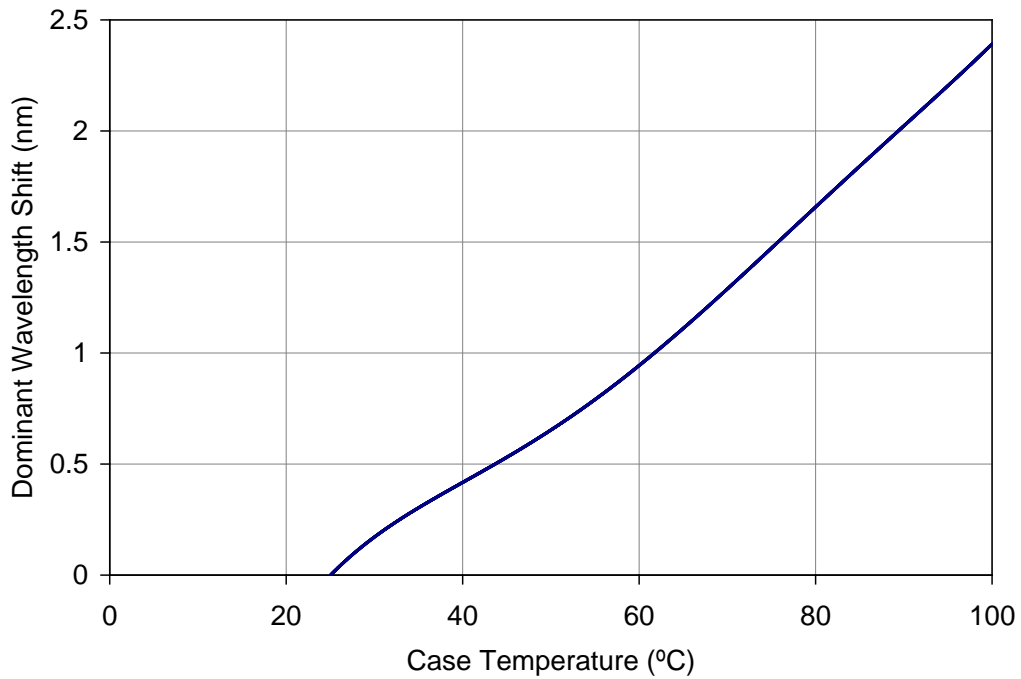

Figure 6: Typical dominant wavelength shift vs. case temperature.

Typical Relative Light Output

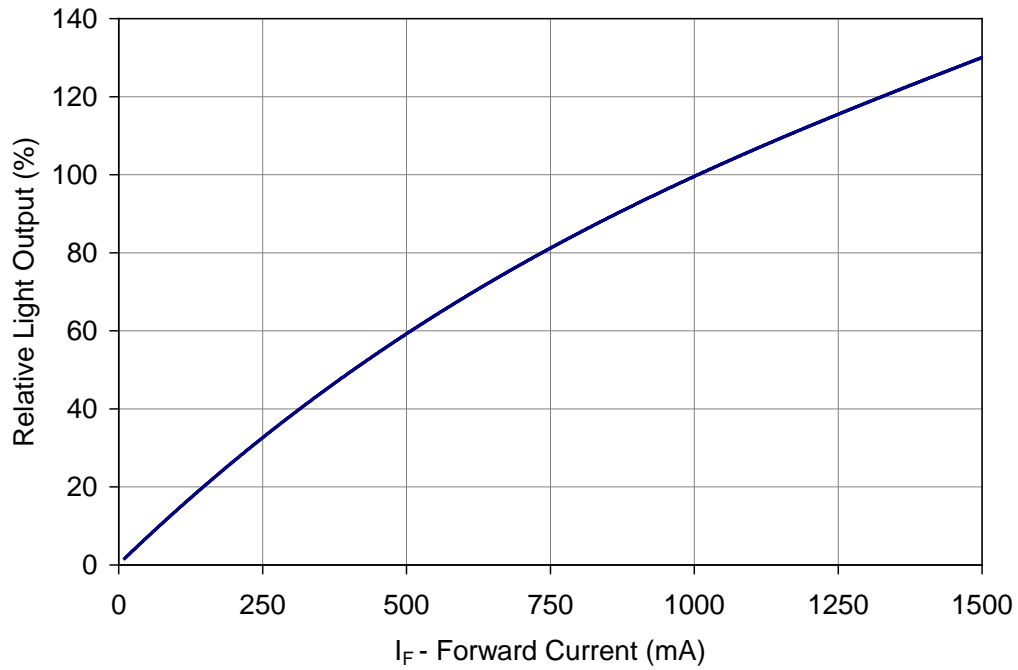

Figure 7: Typical relative light output vs. forward current @ $T_c = 25^\circ\text{C}$.

Typical Relative Light Output over Temperature

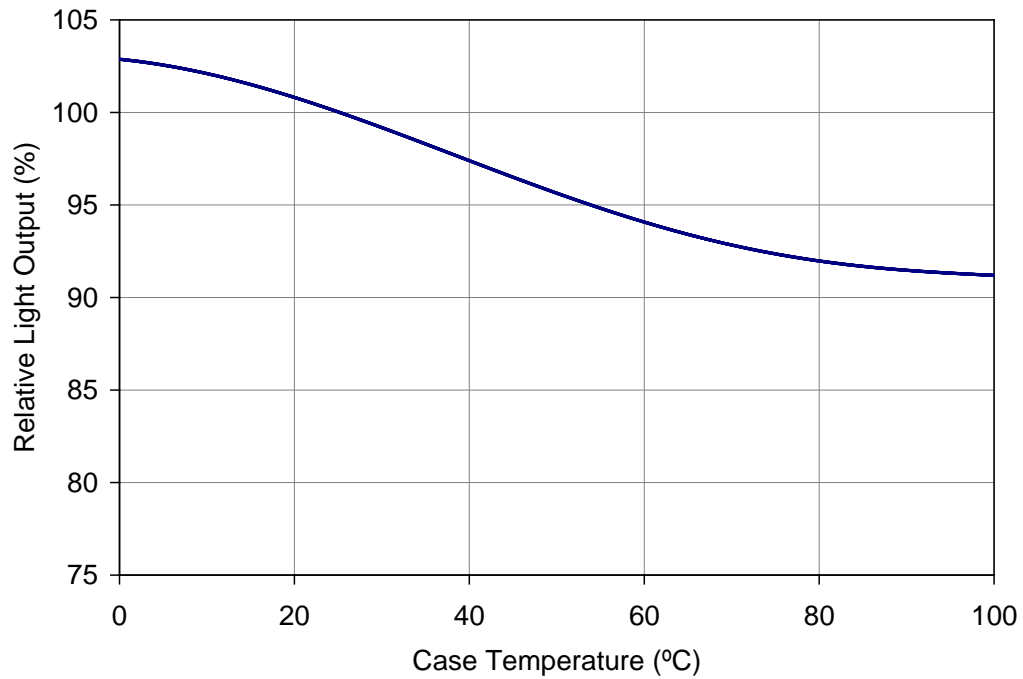

Figure 8: Typical relative light output vs. case temperature.

Typical Forward Current Characteristics

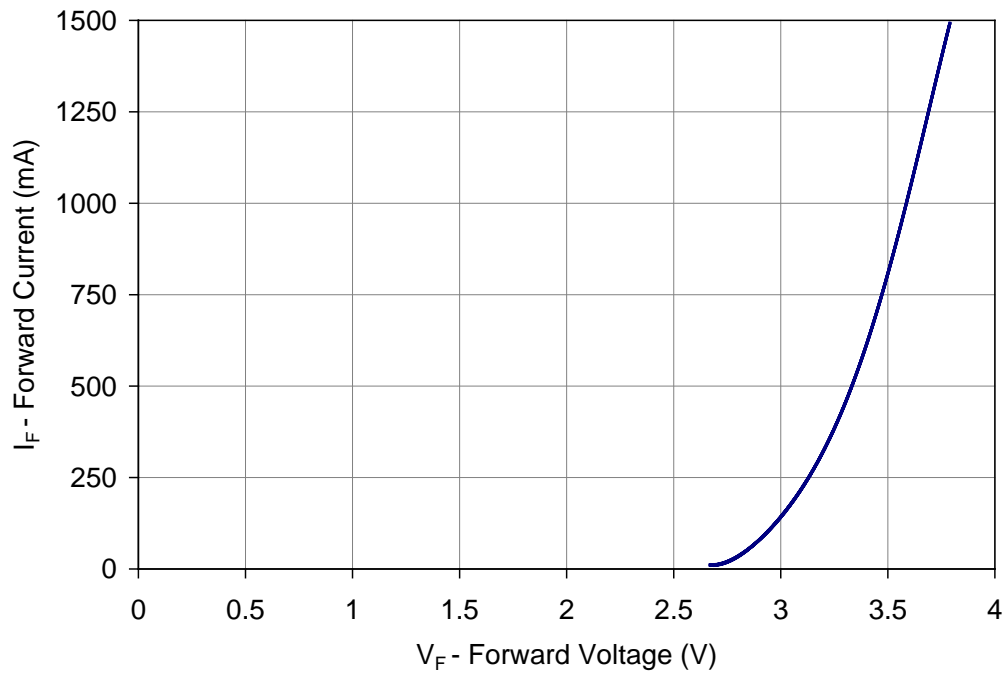

Figure 9: Typical forward current vs. forward voltage @ $T_c = 25^\circ\text{C}$.

Current De-rating

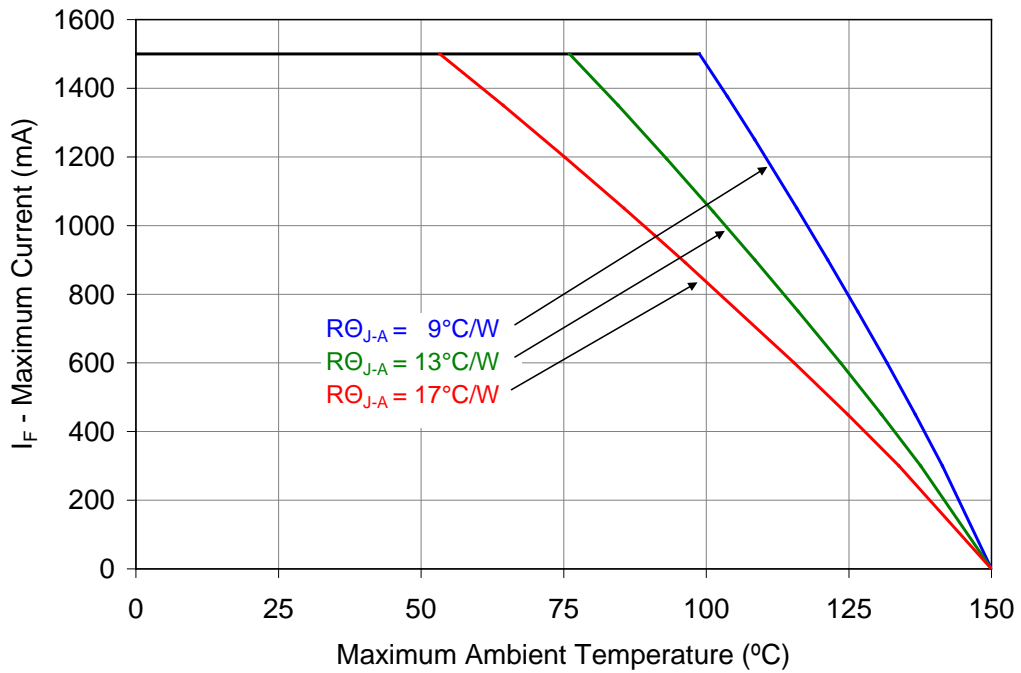

Figure 10: Maximum forward current vs. ambient temperature based on $T_{J(\text{MAX})} = 150^\circ\text{C}$.

Emitter Tape and Reel Specifications (mm)

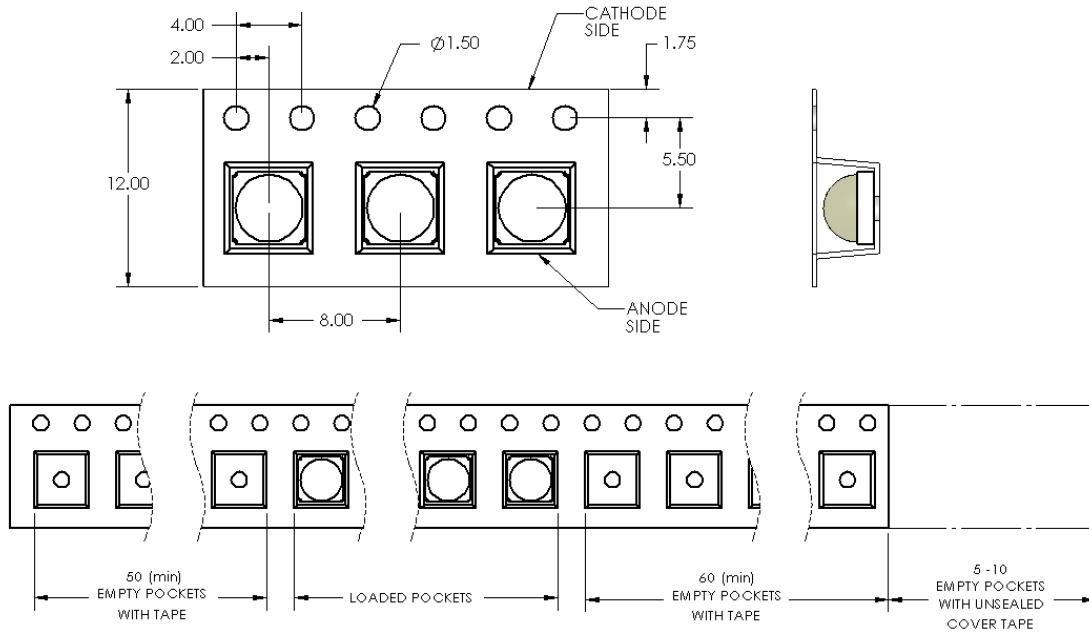

Figure 11: Emitter carrier tape specifications (mm).

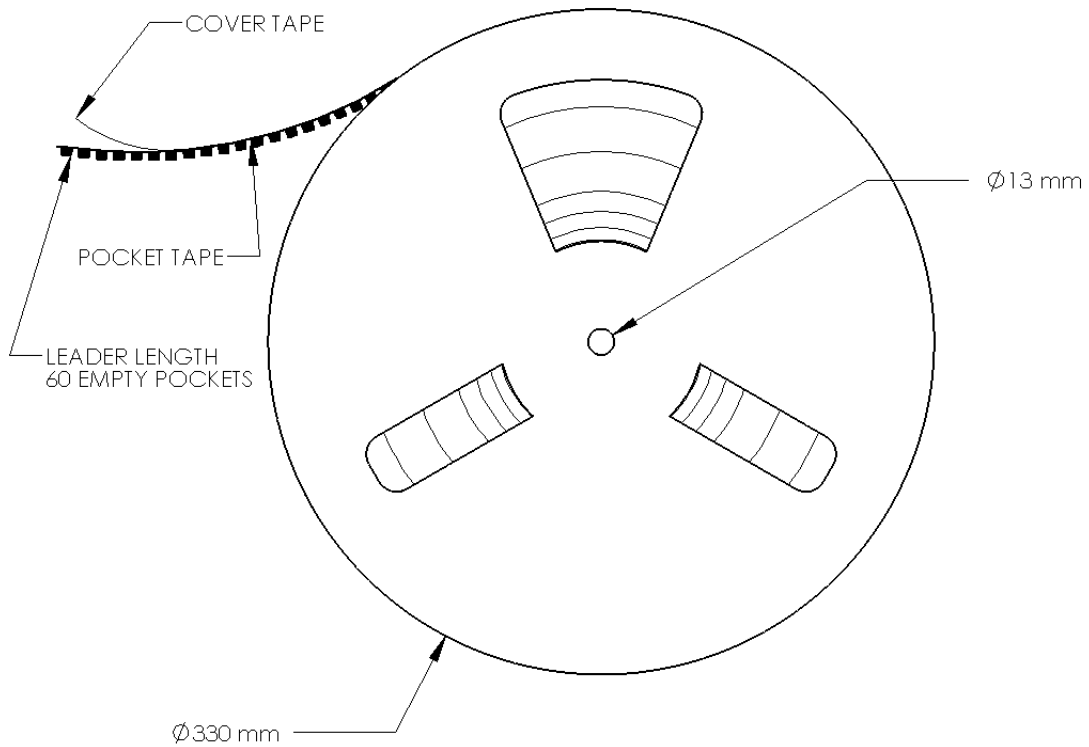

Figure 12: Emitter Reel specifications (mm).

Part-number Nomenclature

The LZ Series base part number designation is defined as follows:

LZ A – B C D E F G – H I J K

A – designates the number of LED die in the package

- 1 for single die emitter package
- 4 for 4-die emitter package
- 9 for 9-die emitter package
- C for 12-die emitter package
- P for 25-die emitter package

B – designates the package level

- 0 for Emitter only

Other letters indicate the addition of a MCPCB. See appendix “MCPCB options” for details

C – designates the radiation pattern

- 0 for Clear domed lens (Lambertian radiation pattern)
- 1 for Flat-top
- 3 for Frosted domed lens

D and E – designates the color

- U6 Ultra Violet (365nm)
- UA Violet (400nm)
- DB Dental Blue (460nm)
- B2 Blue (465nm)
- G1 Green (525nm)
- A1 Amber (590nm)
- R1 Red (623nm)
- R2 Deep Red (660nm)
- R3 Far Red (740nm)
- WW Warm White (2700K-3500K)
- W9 Warm White CRI 90 Minimum (2700K-3500K)
- NW Neutral White (4000K)
- CW Cool White (5500K-6500K)
- W2 Warm & Cool White mixed dies
- MC RGB
- MA RGBA
- MD RGBW (6500K)

F and G – designates the package options if applicable

See “Base part number” on page 2 for details. Default is “00”

H, I, J, K – designates kit options

See “Bin kit options” on page 2 for details. Default is “0000”

Ordering information:

For ordering LED Engin products, please reference the base part number above. The base part number represents our standard full distribution flux and wavelength range. Other standard bin combinations can be found on page 2. For ordering products with custom bin selections, please contact a LED Engin sales representative or authorized distributor.

LZ1 MCPCB Family

Part number	Type of MCPCB	Diameter (mm)	Emitter + MCPCB Thermal Resistance (°C/W)	Typical V_f (V)	Typical I_f (mA)
LZ1-1xxxxxx	1-channel Star	19.9	10.5 + 1.5 = 12.0	3.6	1000
LZ1-3xxxxxx	1-channel Mini	11.5	10.5 + 2.0 = 12.5	3.6	1000

▪ Mechanical Mounting of MCPCB

- Mechanical stress on the emitter that could be caused by bending the MCPCB should be avoided. The stress can cause the substrate to crack and as a result might lead to cracks in the dies.
- Therefore special attention needs to be paid to the flatness of the heat sink surface and the torque on the screws. Maximum torque should not exceed 1 Nm (8.9 lbf/in).
- Care must be taken when securing the board to the heatsink to eliminate bending of the MCPCB. This can be done by tightening the three M3 screws (or #4-40) in steps and not all at once. This is analogous to tightening a wheel of an automobile
- It is recommended to always use plastic washers in combination with three screws. Two screws could more easily lead to bending of the board.
- If non taped holes are used with self-tapping screws it is advised to back out the screws slightly after tighten (with controlled torque) and retighten the screws again.

▪ Thermal interface material

- To properly transfer the heat from the LED to the heatsink a thermally conductive material is required when mounting the MCPCB to the heatsink
- There are several materials which can be used as thermal interface material, such as thermal paste, thermal pads, phase change materials and thermal epoxies. Each has pro's and con's depending on the application. For our emitter it is critical to verify that the thermal resistance is sufficient for the selected emitter and its environment.
- To properly transfer the heat from the MCPCB to the heatsink also special attention should be paid to the flatness of the heatsink.

▪ Wire soldering

- For easy soldering of wires to the MCPCB it is advised to preheat the MCPCB on a hot plate to a maximum of 150°. Subsequently apply the solder and additional heat from the solder iron to initiate a good solder reflow. It is recommended to use a solder iron of more than 60W. We advise to use lead free, no-clean solder. For example SN-96.5 AG-3.0 CU 0.5 #58/275 from Kester (pn: 24-7068-7601)

LZ1-1xxxxx

1 channel, Standard Star MCPCB (1x1) Dimensions (mm)

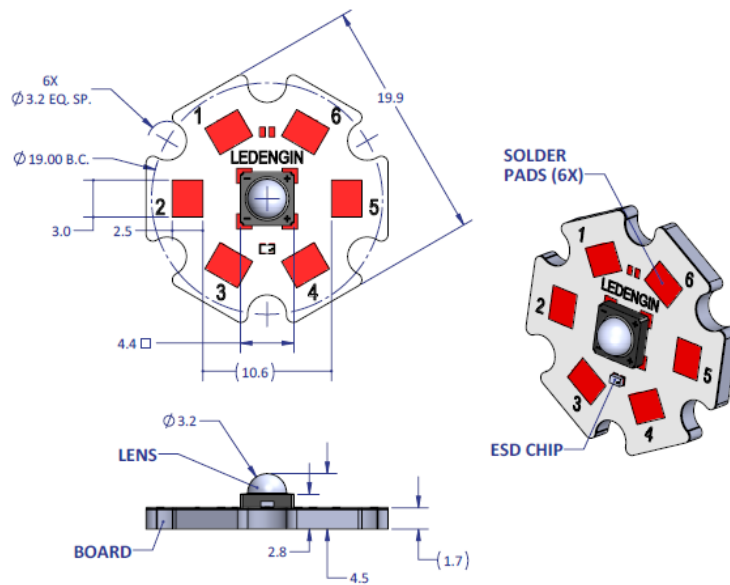

Notes:

- Unless otherwise noted, the tolerance = ± 0.2 mm.
- Slots in MCPCB are for M3 or #4-40 mounting screws.
- LED Engin recommends plastic washers to electrically insulate screws from solder pads and electrical traces.
- Electrical connection pads on MCPCB are labeled “+” for Anode and “-” for Cathode.
- LED Engin recommends using thermal interface material when attaching the MCPCB to a heat sink.
- The thermal resistance of the MCPCB is: $R_{\theta C-B}$ 1.5°C/W

Components used

MCPCB: HT04503 (Bergquist)
 ESD chips: BZT52C5-C10 (NPX, for 1 LED die)

Pad layout			
Ch.	MCPCB Pad	String/die	Function
1	1,2,3	1/A	Cathode -
	4,5,6		Anode +

LZ1-3xxxxx

1 channel, Mini Round MCPCB (1x1) Dimensions (mm)

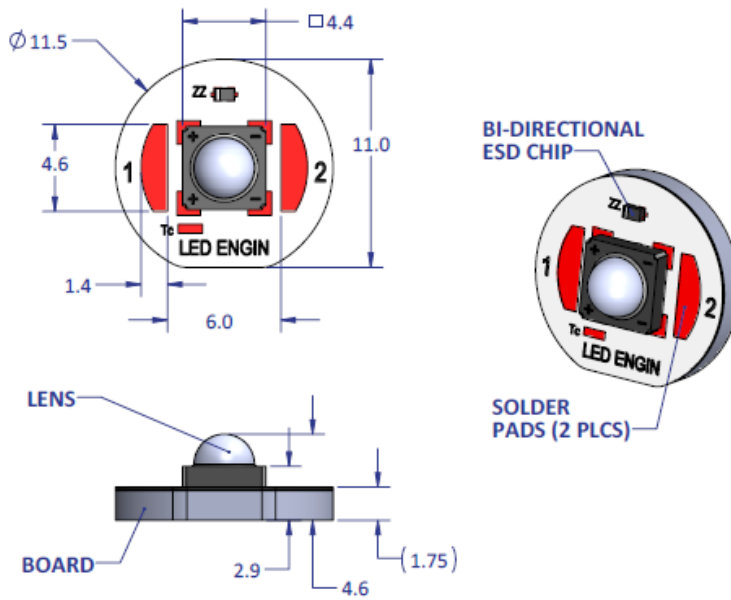

Notes:

- Unless otherwise noted, the tolerance = ± 0.20 mm.
- Electrical connection pads on MCPCB are labeled “+” for Anode and “-” for Cathode.
- LED Engin recommends using thermal interface material when attaching the MCPCB to a heat sink.
- The thermal resistance of the MCPCB is: R θ C-B 2.0°C/W

Components used

MCPCB: HT04503 (Bergquist)
 ESD chips: BZT52C5-C10 (NPX, for 1 LED die)

Pad layout			
Ch.	MCPCB Pad	String/die	Function
1	1	1/A	Anode +
	2		Cathode -

Company Information

LED Engin, Inc., based in California's Silicon Valley, specializes in ultra-bright, ultra compact solid state lighting solutions allowing lighting designers & engineers the freedom to create uncompromised yet energy efficient lighting experiences. The LuxiGen™ Platform — an emitter and lens combination or integrated module solution, delivers superior flexibility in light output, ranging from 3W to 90W, a wide spectrum of available colors, including whites, multi-color and UV, and the ability to deliver upwards of 5,000 high quality lumens to a target. The small size combined with powerful output allows for a previously unobtainable freedom of design wherever high-flux density, directional light is required. LED Engin's packaging technologies lead the industry with products that feature lowest thermal resistance, highest flux density and consummate reliability, enabling compact and efficient solid state lighting solutions.

LED Engin is committed to providing products that conserve natural resources and reduce greenhouse emissions.

LED Engin reserves the right to make changes to improve performance without notice.

Please contact sales@ledengin.com or (408) 922-7200 for more information.