

FEATURES

- Complete Switch Mode Power Supply
- Wide Input Voltage Range: 4.5V to 20V
- 6A DC Typical, 8A Peak Output Current
- 0.6V to 5V Output Voltage
- Output Voltage Tracking and Margining
- Remote Sensing for Precision Regulation (LTM4603 Only)
- Typical Operating Frequency: 1MHz
- PLL Frequency Synchronization
- 1.5% Regulation
- Current Foldback Protection (Disabled at Start-Up)
- Pin Compatible with the LTM4601
- Pb-Free (e4) RoHS Compliant Package with Gold Finish Pads
- Ultrafast Transient Response
- Current Mode Control
- Up to 93% Efficiency at 5V_{IN}, 3.3V_{OUT}
- Programmable Soft-Start
- Output Overvoltage Protection
- Small Footprint, Low Profile (15mm × 15mm × 2.8mm) Surface Mount LGA Package

APPLICATIONS

- Telecom and Networking Equipment
- Servers
- Industrial Equipment
- Point of Load Regulation

DESCRIPTION

The LTM[®]4603 is a complete 6A step-down switch mode DC/DC power supply with onboard switching controller, MOSFETs, inductor and all support components. The μ Module[™] is housed in a small surface mount 15mm × 15mm × 2.8mm LGA package. Operating over an input voltage range of 4.5 to 20V, the LTM4603 supports an output voltage range of 0.6V to 5V as well as output voltage tracking and margining. The high efficiency design delivers 6A continuous current (8A peak). Only bulk input and output capacitors are needed to complete the design.

The low profile (2.8mm) and light weight (1.7g) package easily mounts on the unused space on the back side of PC boards for high density point of load regulation. The μ Module can be synchronized with an external clock for reducing undesirable frequency harmonics and allows PolyPhase[®] operation for high load currents.

A high switching frequency and adaptive on-time current mode architecture deliver a very fast transient response to line and load changes without sacrificing stability. An onboard remote sense amplifier can be used to accurately regulate an output voltage independent of load current. The onboard remote sense amplifier is not available in the LTM4603-1. The LTM4603/LTM4603-1 are pin compatible with the 12A LTM4601/LTM4601-1.

LT, LT, LTC, LTM and PolyPhase are registered trademarks of Linear Technology Corporation. μ Module is a trademark of Linear Technology Corporation. All other trademarks are the property of their respective owners.

TYPICAL APPLICATION

1.5V/6A Power Supply with 4.5V to 20V Input

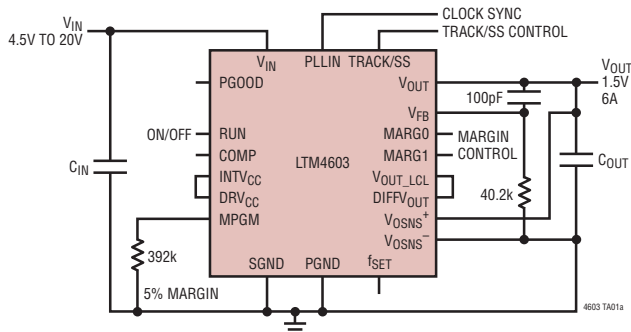

Efficiency vs Load Current with 12V_{IN}

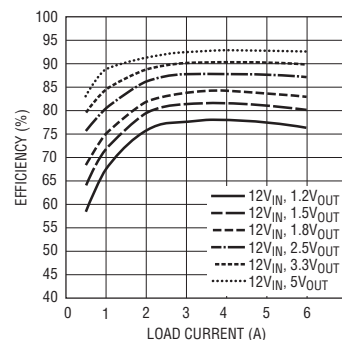

LTM4603/LTM4603-1

ABSOLUTE MAXIMUM RATINGS

(Note 1)

| | |
|--|------------------------------------|
| INTV _{CC} , DRV _{CC} , V _{OUT_LCL} , V _{OUT} (V _{OUT} ≤ 3.3V with Remote Sense Amp) | -0.3V to 6V |
| PLLIN, TRACK/SS, MPGM, MARG0, MARG1, PGOOD, f _{SET} | -0.3V to INTV _{CC} + 0.3V |
| RUN | -0.3V to 5V |
| V _{FB} , COMP | -0.3V to 2.7V |
| V _{IN} | -0.3V to 20V |
| V _{OSNS} ⁺ , V _{OSNS} ⁻ | -0.3V to INTV _{CC} + 0.3V |
| Operating Temperature Range (Note 2) | -40°C to 85°C |
| Junction Temperature | 125°C |
| Storage Temperature Range | -55°C to 125°C |

PIN CONFIGURATION

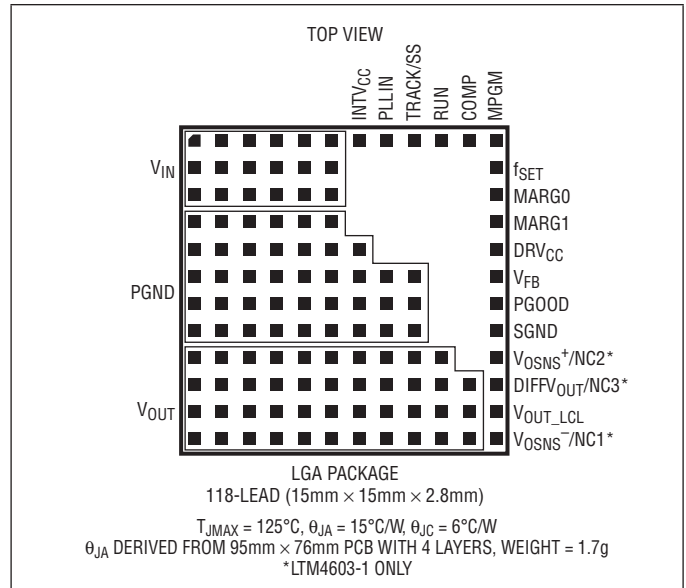

ORDER INFORMATION

| LEAD FREE FINISH | TRAY | PART MARKING* | PACKAGE DESCRIPTION | TEMPERATURE RANGE |
|------------------|-----------------|---------------|------------------------------------|-------------------|
| LTM4603EV#PBF | LTM4603EV#PBF | LTM4603V | 118-Lead (15mm × 15mm × 2.8mm) LGA | -40°C to 85°C |
| LTM4603IV#PBF | LTM4603IV#PBF | LTM4603V | 118-Lead (15mm × 15mm × 2.8mm) LGA | -40°C to 85°C |
| LTM4603EV-1#PBF | LTM4603EV-1#PBF | LTM4603V-1 | 118-Lead (15mm × 15mm × 2.8mm) LGA | -40°C to 85°C |
| LTM4603IV-1#PBF | LTM4603IV-1#PBF | LTM4603V-1 | 118-Lead (15mm × 15mm × 2.8mm) LGA | -40°C to 85°C |

Consult LTC Marketing for parts specified with wider operating temperature ranges. *The temperature grade is identified by a label on the shipping container.

For more information on lead free part marking, go to: <http://www.linear.com/leadfree/>

This product is only offered in trays. For more information go to: <http://www.linear.com/packaging/>

ELECTRICAL CHARACTERISTICS

The ● denotes the specifications which apply over the -40°C to 85°C temperature range, otherwise specifications are at T_A = 25°C, V_{IN} = 12V. Per typical application (front page) configuration.

| SYMBOL | PARAMETER | CONDITIONS | MIN | TYP | MAX | UNITS |
|----------------------|------------------|--|--------------------|------------|----------------|--------|
| V _{IN(DC)} | Input DC Voltage | | ● 4.5 | | 20 | V |
| V _{OUT(DC)} | Output Voltage | C _{IN} = 10μF × 2, C _{OUT} = 2 ×, 100μF/X5R/ Ceramic V _{IN} = 5V, V _{OUT} = 1.5V, I _{OUT} = 0A V _{IN} = 12V, V _{OUT} = 1.5V, I _{OUT} = 0A | ● 1.478 ● 1.478 | 1.5 1.5 | 1.522 1.522 | V V |

Input Specifications

| | | | | | | |
|--------------------------|----------------------------------|---|--|------------|---|--------|
| V _{IN(UVLO)} | Undervoltage Lockout Threshold | I _{OUT} = 0A | | 3.2 | 4 | V |
| I _{INRUSH(VIN)} | Input Inrush Current at Start-Up | I _{OUT} = 0A, V _{OUT} = 1.5V V _{IN} = 5V V _{IN} = 12V | | 0.6 0.7 | | A A |

4603fa

ELECTRICAL CHARACTERISTICS

The ● denotes the specifications which apply over the -40°C to 85°C temperature range, otherwise specifications are at $T_A = 25^{\circ}\text{C}$, $V_{IN} = 12\text{V}$. Per typical application (front page) configuration.

| SYMBOL | PARAMETER | CONDITIONS | MIN | TYP | MAX | UNITS |
|---------------------|---|---|-----|------|-----|---------------|
| $I_{Q(VIN,NOLOAD)}$ | Input Supply Bias Current | $V_{IN} = 12\text{V}$, No Switching | | 3.8 | | mA |
| | | $V_{IN} = 12\text{V}$, $V_{OUT} = 1.5\text{V}$, Switching Continuous | | 25 | | mA |
| | | $V_{IN} = 5\text{V}$, No Switching | | 2.5 | | mA |
| | | $V_{IN} = 5\text{V}$, $V_{OUT} = 1.5\text{V}$, Switching Continuous | | 43 | | mA |
| | | Shutdown, $RUN = 0$, $V_{IN} = 12\text{V}$ | | 22 | | μA |
| $I_{S(VIN)}$ | Input Supply Current | $V_{IN} = 12\text{V}$, $V_{OUT} = 1.5\text{V}$, $I_{OUT} = 6\text{A}$ | | 0.92 | | A |
| | | $V_{IN} = 12\text{V}$, $V_{OUT} = 3.3\text{V}$, $I_{OUT} = 6\text{A}$ | | 1.83 | | A |
| | | $V_{IN} = 5\text{V}$, $V_{OUT} = 1.5\text{V}$, $I_{OUT} = 6\text{A}$ | | 2.12 | | A |
| $INTV_{CC}$ | $V_{IN} = 12\text{V}$, $RUN > 2\text{V}$ | No Load | 4.7 | 5 | 5.3 | V |

Output Specifications

| | | | | | | |
|---------------------------------|---|---|--------|------|------|-------------------|
| I_{OUTDC} | Output Continuous Current Range | $V_{IN} = 12\text{V}$, $V_{OUT} = 1.5\text{V}$ (Note 5) | | 0 | 6 | A |
| $\frac{V_{OUT(LINE)}}{V_{OUT}}$ | Line Regulation Accuracy | $V_{OUT} = 1.5\text{V}$, $I_{OUT} = 0\text{A}$, $V_{IN} = 4.5\text{V}$ to 20V | ● | | 0.3 | % |
| $\frac{V_{OUT(LOAD)}}{V_{OUT}}$ | Load Regulation Accuracy | $V_{OUT} = 1.5\text{V}$, $I_{OUT} = 0\text{A}$ to 6A (Note 5) $V_{IN} = 12\text{V}$, with Remote Sense Amp $V_{IN} = 12\text{V}$, LTM4603-1 | ● ● | | 0.25 | % |
| | | | | | 0.5 | % |
| $V_{OUT(AC)}$ | Output Ripple Voltage | $I_{OUT} = 0\text{A}$, $C_{OUT} = 2\times$, $100\mu\text{F}$ X5R Ceramic $V_{IN} = 12\text{V}$, $V_{OUT} = 1.5\text{V}$ $V_{IN} = 5\text{V}$, $V_{OUT} = 1.5\text{V}$ | | 10 | | mV _{p-p} |
| | | | | 10 | | mV _{p-p} |
| f_S | Output Ripple Voltage Frequency | $I_{OUT} = 3\text{A}$, $V_{IN} = 12\text{V}$, $V_{OUT} = 1.5\text{V}$ | | 1000 | | kHz |
| $\Delta V_{OUT(START)}$ | Turn-On Overshoot, TRACK/SS = 10nF | $C_{OUT} = 2\times$, $100\mu\text{F}$ X5R Ceramic, $V_{OUT} = 1.5\text{V}$, $I_{OUT} = 0\text{A}$ $V_{IN} = 12\text{V}$ $V_{IN} = 5\text{V}$ | | 20 | 20 | mV mV |
| t_{START} | Turn-On Time, TRACK/SS = Open | $C_{OUT} = 2\times$, $100\mu\text{F}$ X5R Ceramic, $V_{OUT} = 1.5\text{V}$, $I_{OUT} = 1\text{A}$ Resistive Load $V_{IN} = 12\text{V}$ $V_{IN} = 5\text{V}$ | | 0.5 | 0.5 | ms ms |
| ΔV_{OUTLS} | Peak Deviation for Dynamic Load | Load: 0% to 50% to 0% of Full Load, $C_{OUT} = 2 \times 22\mu\text{F}$ Ceramic, $470\mu\text{F}$ 4V Sanyo POSCAP $V_{IN} = 12\text{V}$ $V_{IN} = 5\text{V}$ | | 35 | 35 | mV mV |
| t_{SETTLE} | Settling Time for Dynamic Load Step | Load: 0% to 50% to 10% of Full Load $V_{IN} = 12\text{V}$ | | 25 | | μs |
| I_{OUTPK} | Output Current Limit | $C_{OUT} = 2\times$, $100\mu\text{F}$ X5R Ceramic $V_{IN} = 12\text{V}$, $V_{OUT} = 1.5\text{V}$ $V_{IN} = 5\text{V}$, $V_{OUT} = 1.5\text{V}$ | | 8 | | A |
| | | | | 8 | | A |

Remote Sense Amp (LTM4603 Only, Not Supported in the LTM4603-1) (Note 3)

| | | | | | | |
|---|---------------------------------|--|--|---|-----------------|------------------|
| V_{OSNS^+} , V_{OSNS^-} CM Range | Common Mode Input Voltage Range | $V_{IN} = 12\text{V}$, $RUN > 2\text{V}$ | | 0 | $INTV_{CC} - 1$ | V |
| $DIFFV_{OUT}$ Range | Output Voltage Range | $V_{IN} = 12\text{V}$, $DIFFV_{OUT}$ Load = 100k | | 0 | $INTV_{CC}$ | V |
| V_{OS} | Input Offset Voltage Magnitude | | | | 1.25 | mV |
| AV | Differential Gain | | | 1 | | V/V |
| GBP | Gain Bandwidth Product | | | 3 | | MHz |
| SR | Slew Rate | | | 2 | | V/ μs |

LTM4603/LTM4603-1

ELECTRICAL CHARACTERISTICS

The ● denotes the specifications which apply over the -40°C to 85°C temperature range, otherwise specifications are at $T_A = 25^{\circ}\text{C}$, $V_{IN} = 12\text{V}$. Per typical application (front page) configuration.

| SYMBOL | PARAMETER | CONDITIONS | MIN | TYP | MAX | UNITS | |
|---------------------------|--|--|--------|-------|--------|------------------|---|
| R_{IN} | Input Resistance | V_{OSNS}^+ to GND | | 20 | | $\text{k}\Omega$ | |
| CMRR | Common Mode Rejection Ratio | | | 100 | | dB | |
| Control Stage | | | | | | | |
| V_{FB} | Error Amplifier Input Voltage Accuracy | $I_{OUT} = 0\text{A}$, $V_{OUT} = 1.5\text{V}$ | ● | 0.594 | 0.6 | 0.606 | V |
| V_{RUN} | RUN Pin On/Off Threshold | | 1 | 1.5 | 1.9 | V | |
| $I_{SS/TRACK}$ | Soft-Start Charging Current | $V_{SS/TRACK} = 0\text{V}$ | -1 | -1.5 | -2 | μA | |
| $t_{ON(MIN)}$ | Minimum On Time | (Note 4) | | 50 | 100 | ns | |
| $t_{OFF(MIN)}$ | Minimum Off Time | (Note 4) | | 250 | 400 | ns | |
| R_{PLLIN} | PLLIN Input Resistance | | | 50 | | $\text{k}\Omega$ | |
| I_{DRVCC} | Current into DRV_{CC} Pin | $V_{OUT} = 1.5\text{V}$, $I_{OUT} = 1\text{A}$, $DRV_{CC} = 5\text{V}$ | | 18 | 25 | mA | |
| R_{FBHI} | Resistor Between V_{OUT_LCL} and V_{FB} | | 60.098 | 60.4 | 60.702 | $\text{k}\Omega$ | |
| V_{MPGM} | Margin Reference Voltage | | | 1.18 | | V | |
| V_{MARG0} , V_{MARG1} | MARG0, MARG1 Voltage Thresholds | | | 1.4 | | V | |
| PGOOD Output | | | | | | | |
| ΔV_{FBH} | PGOOD Upper Threshold | V_{FB} Rising | | 7 | 10 | 13 | % |
| ΔV_{FBL} | PGOOD Lower Threshold | V_{FB} Falling | | -7 | -10 | -13 | % |
| $\Delta V_{FB(HYS)}$ | PGOOD Hysteresis | V_{FB} Returning (Note 4) | | 1.5 | 3 | | % |
| V_{PGL} | PGOOD Low Voltage | $I_{PGOOD} = 5\text{mA}$ | | 0.15 | 0.4 | V | |

Note 1: Stresses beyond those listed under Absolute Maximum Ratings may cause permanent damage to the device. Exposure to any Absolute Maximum Rating condition for extended periods may affect device reliability and lifetime.

Note 2: The LTM4603E/LTM4603E-1 are guaranteed to meet performance specifications from 0°C to 85°C . Specifications over the -40°C to 85°C operating temperature range are assured by design, characterization and correlation with statistical process controls. The LTM4603I/LTM4603I-1 are guaranteed over the -40°C to 85°C temperature range.

Note 3: Remote sense amplifier recommended for $\leq 3.3\text{V}$ output.

Note 4: 100% tested at wafer sort only.

Note 5: See output current derating curves for different V_{IN} , V_{OUT} and T_A .

TYPICAL PERFORMANCE CHARACTERISTICS (See Figure 18 for all curves)

Efficiency vs Load Current with 5V_{IN}

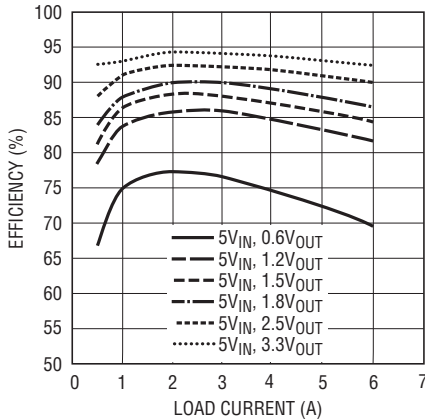

4603 G01

Efficiency vs Load Current with 12V_{IN}

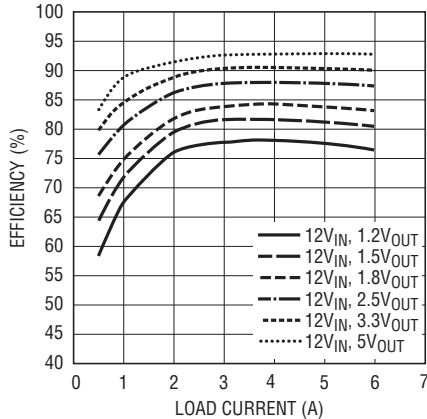

4603 G02

Efficiency vs Load Current with 20V_{IN}

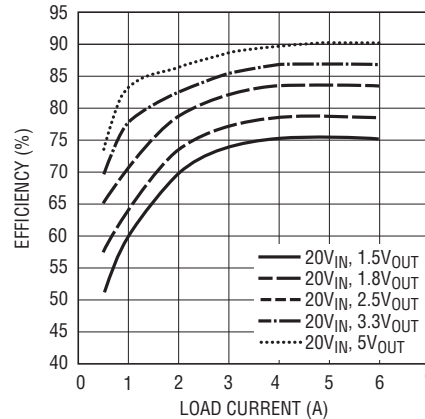

4603 G03

1.2V Transient Response

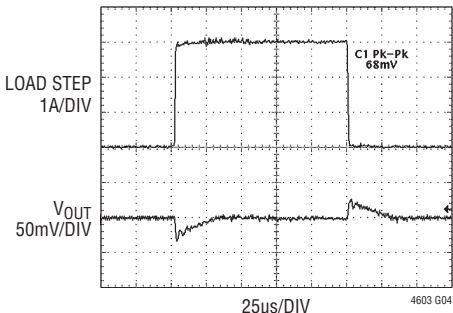

4603 G04

1.2V AT 3A/μs LOAD STEP
C_{OUT}: 1× 22μF, 6.3V CERAMIC
1× 330μF, 4V SANYO POSCAP

1.5V Transient Response

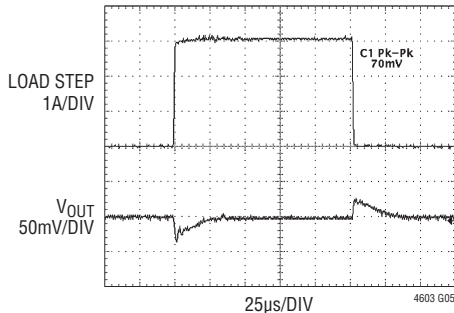

4603 G05

1.5V AT 3A/μs LOAD STEP
C_{OUT}: 1× 22μF, 6.3V CERAMIC
1× 330μF, 4V SANYO POSCAP

1.8V Transient Response

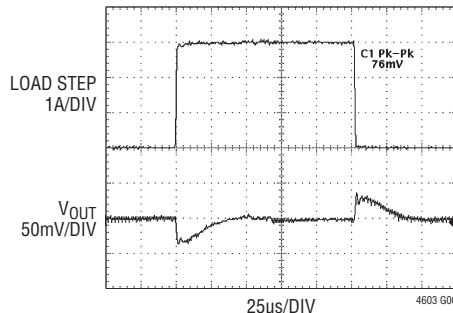

4603 G06

1.8V AT 3A/μs LOAD STEP
C_{OUT}: 1× 22μF, 6.3V CERAMIC
1× 330μF, 4V SANYO POSCAP

2.5V Transient Response

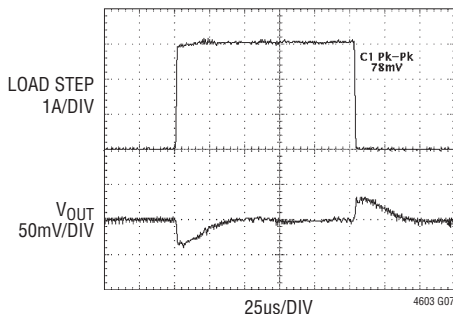

4603 G07

2.5V AT 3A/μs LOAD STEP
C_{OUT}: 1× 22μF, 6.3V CERAMIC
1× 330μF, 4V SANYO POSCAP

3.3V Transient Response

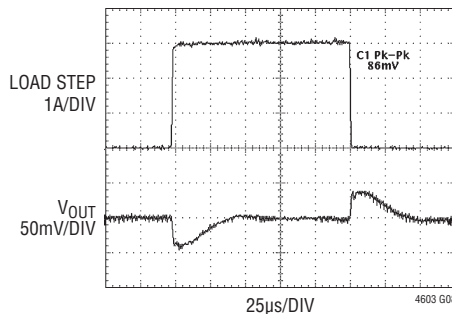

4603 G08

3.3V AT 3A/μs LOAD STEP
C_{OUT}: 1× 22μF, 6.3V CERAMIC
1× 330μF, 4V SANYO POSCAP

TYPICAL PERFORMANCE CHARACTERISTICS (See Figure 18 for all curves)

Start-Up, $I_{OUT} = 0A$

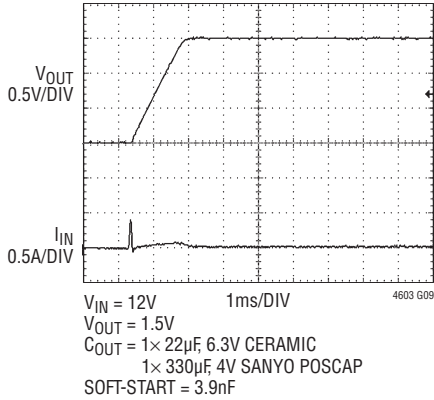

**Start-Up, $I_{OUT} = 6A$
(Resistive Load)**

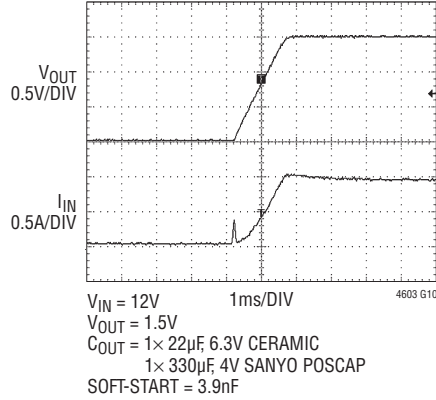

**Short-Circuit Protection,
 $I_{OUT} = 0A$**

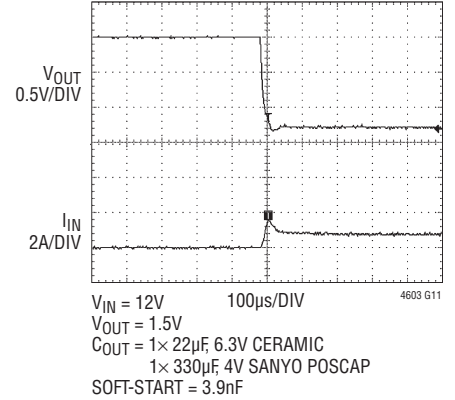

**Short-Circuit Protection,
 $I_{OUT} = 6A$**

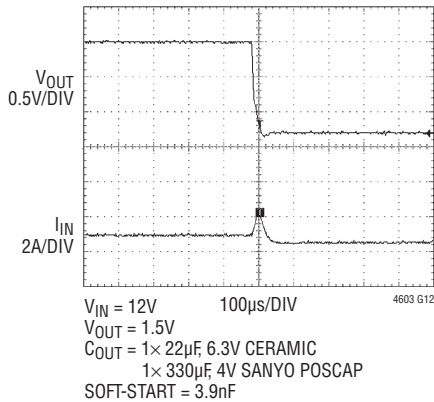

V_{IN} to V_{OUT} Step-Down Ratio

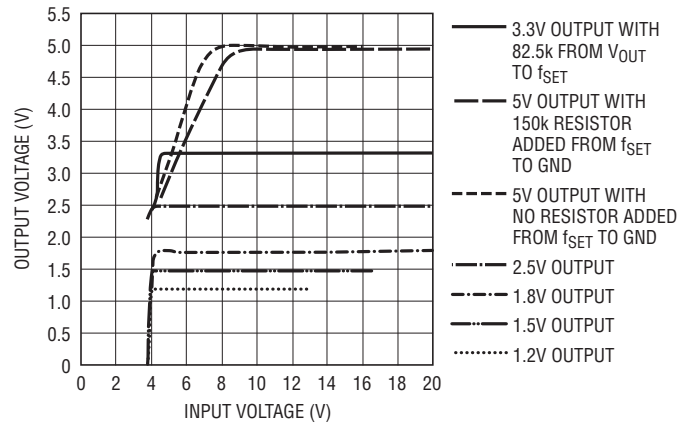

4603 G13

PIN FUNCTIONS (See Package Description for Pin Assignment)

V_{IN} (Bank 1): Power Input Pins. Apply input voltage between these pins and PGND pins. Recommend placing input decoupling capacitance directly between V_{IN} pins and PGND pins.

V_{OUT} (Bank 3): Power Output Pins. Apply output load between these pins and PGND pins. Recommend placing output decoupling capacitance directly between these pins and PGND pins. Review the figure below.

PGND (Bank 2): Power ground pins for both input and output returns.

V_{OSNS}^- (Pin M12): (–) Input to the Remote Sense Amplifier. This pin connects to the ground remote sense point. The remote sense amplifier is used for $V_{OUT} \leq 3.3V$.

NC1 (Pin M12): No Connect on the LTM4603-1.

V_{OSNS}^+ (Pin J12): (+) Input to the Remote Sense Amplifier. This pin connects to the output remote sense point. The remote sense amplifier is used for $V_{OUT} \leq 3.3V$.

NC2 (Pin J12): No Connect on the LTM4603-1.

DIFF V_{OUT} (Pin K12): Output of the Remote Sense Amplifier. This pin connects to the V_{OUT_LCL} pin.

NC3 (Pin K12): No Connect on the LTM4603-1.

DRV $_{CC}$ (Pin E12): This pin normally connects to INTV $_{CC}$ for powering the internal MOSFET drivers. This pin can be biased up to 6V from an external supply with about 50mA capability, or an external circuit shown in Figure 16. This improves efficiency at the higher input voltages by reducing power dissipation in the module.

INTV $_{CC}$ (Pin A7): This pin is for additional decoupling of the 5V internal regulator.

PLLIN (Pin A8): External Clock Synchronization Input to the Phase Detector. This pin is internally terminated to SGND with a 50k resistor. Apply a clock above 2V and below INTV $_{CC}$. See Applications Information.

TRACK/SS (Pin A9): Output Voltage Tracking and Soft-Start Pin. When the module is configured as a master output, then a soft-start capacitor is placed on this pin to ground to control the master ramp rate. A soft-start capacitor can be used for soft-start turn on as a stand alone regulator. Slave operation is performed by putting a resistor divider from the master output to the ground, and connecting the center point of the divider to this pin. See Applications Information.

MPGM (Pin A12): Programmable Margining Input. A resistor from this pin to ground sets a current that is equal to $1.18V/R$. This current multiplied by $10k\Omega$ will equal a value in millivolts that is a percentage of the 0.6V reference voltage. See Applications Information. To parallel LTM4603s, each requires an individual MPGM resistor. Do not tie MPGM pins together.

f $_{SET}$ (Pin B12): Frequency Set Internally to 1MHz. An external resistor can be placed from this pin to ground to increase frequency. This pin can be decoupled with a 1000pF capacitor. See Applications Information for frequency adjustment.

V_{FB} (Pin F12): The Negative Input of the Error Amplifier. Internally, this pin is connected to V_{OUT_LCL} with a 60.4k precision resistor. Different output voltages can be programmed with an additional resistor between V_{FB} and SGND pins. See Applications Information.

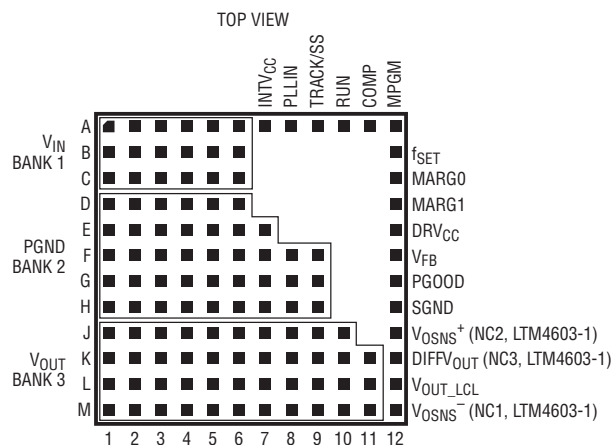

PIN FUNCTIONS (See Package Description for Pin Assignment)

MARG0 (Pin C12): This pin is the LSB logic input for the margining function. Together with the MARG1 pin will determine if margin high, margin low or no margin state is applied. The pin has an internal pull-down resistor of 50k. See Applications Information.

MARG1 (Pin D12): This pin is the MSB logic input for the margining function. Together with the MARG0 pin will determine if margin high, margin low or no margin state is applied. The pin has an internal pull-down resistor of 50k. See Applications Information.

SGND (Pin H12): Signal Ground. This pin connects to PGND at output capacitor point.

COMP (Pin A11): Current Control Threshold and Error Amplifier Compensation Point. The current comparator threshold increases with this control voltage. The voltage ranges from 0V to 2.4V with 0.7V corresponding to zero sense voltage (zero current).

PGOOD (Pin G12): Output Voltage Power Good Indicator. Open-drain logic output that is pulled to ground when the output voltage is not within $\pm 10\%$ of the regulation point, after a 25 μ s power bad mask timer expires.

RUN (Pin A10): Run Control Pin. A voltage above 1.9V will turn on the module, and when below 1V, will turn off the module. A programmable UVLO function can be accomplished with a resistor from V_{IN} to this pin that has a 5.1V zener to ground. Maximum pin voltage is 5V. Limit current into the RUN pin to less than 1mA.

V_{OUT_LCL} (Pin L12): V_{OUT} connects directly to this pin to bypass the remote sense amplifier, or $DIFFV_{OUT}$ connects to this pin when remote sense amplifier is used. V_{OUT_LCL} can be connected to V_{OUT} on the LTM4603-1. V_{OUT} is internally connected to V_{OUT_LCL} through 50 Ω in the LTM4603-1.

SIMPLIFIED BLOCK DIAGRAM

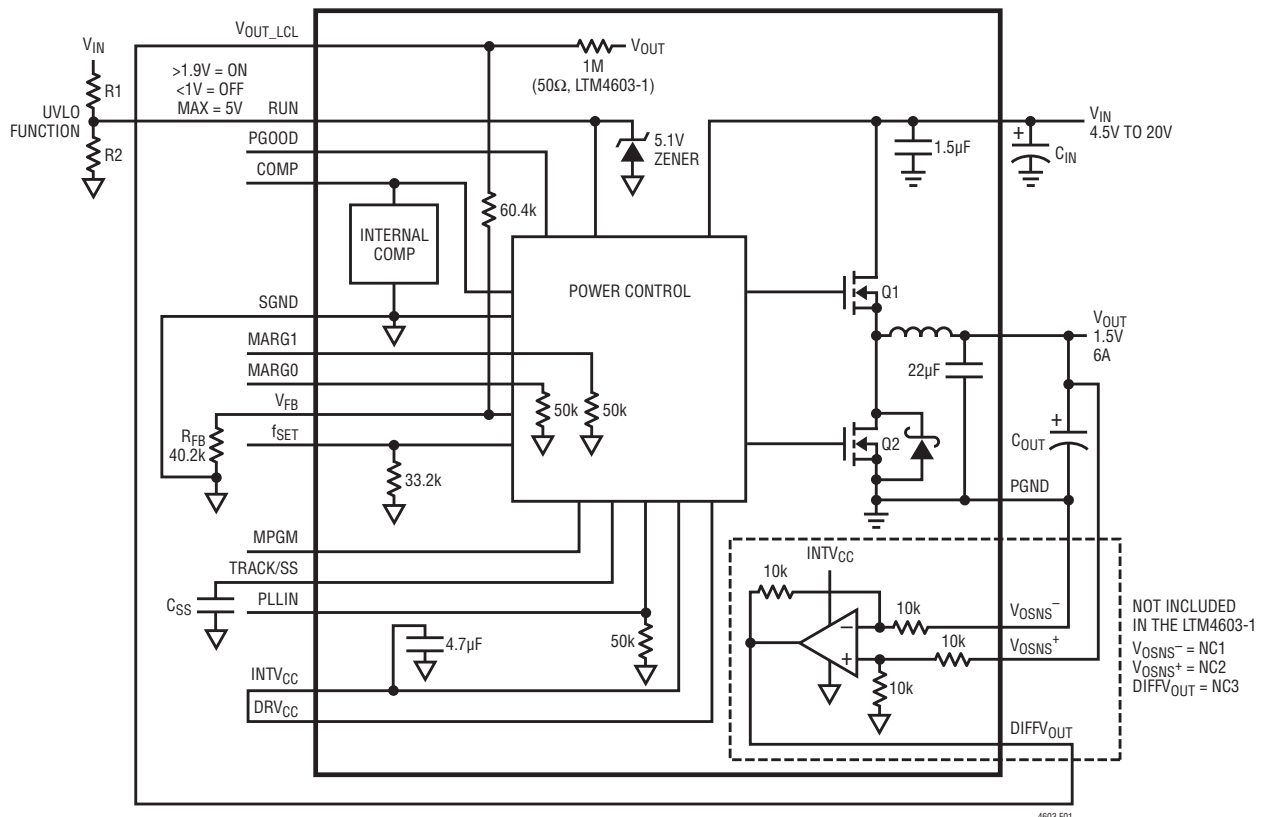

Figure 1. Simplified LTM4603/LTM4603-1 Block Diagram

DECOUPLING REQUIREMENTS $T_A = 25^\circ\text{C}$, $V_{IN} = 12\text{V}$. Use Figure 1 configuration.

| SYMBOL | PARAMETER | CONDITIONS | MIN | TYP | MAX | UNITS |
|-----------|--|-----------------------|-----|-----|-----|---------------|
| C_{IN} | External Input Capacitor Requirement ($V_{IN} = 4.5\text{V}$ to 20V , $V_{OUT} = 1.5\text{V}$) | $I_{OUT} = 6\text{A}$ | 20 | | | μF |
| C_{OUT} | External Output Capacitor Requirement ($V_{IN} = 4.5\text{V}$ to 20V , $V_{OUT} = 1.5\text{V}$) | $I_{OUT} = 6\text{A}$ | 100 | 200 | | μF |

OPERATION**Power Module Description**

The LTM4603 is a standalone nonisolated switching mode DC/DC power supply. It can deliver up to 6A of DC output current with few external input and output capacitors. This module provides precisely regulated output voltage programmable via one external resistor from $0.6V_{DC}$ to $5.0V_{DC}$ over a 4.5V to 20V wide input voltage. The typical application schematic is shown in Figure 18.

The LTM4603 has an integrated constant on-time current mode regulator, ultralow $R_{DS(ON)}$ FETs with fast switching speed and integrated Schottky diodes. The typical switching frequency is 1MHz at full load. With current mode control and internal feedback loop compensation, the LTM4603 module has sufficient stability margins and good transient performance under a wide range of operating conditions and with a wide range of output capacitors, even all ceramic output capacitors.

Current mode control provides cycle-by-cycle fast current limit. Besides, foldback current limiting is provided in an overcurrent condition while V_{FB} drops. Internal overvoltage and undervoltage comparators pull the open-drain PGOOD output low if the output feedback voltage exits a $\pm 10\%$ window around the regulation point. Furthermore, in an overvoltage condition, internal top FET Q1 is turned off

and bottom FET Q2 is turned on and held on until the overvoltage condition clears.

Pulling the RUN pin below 1V forces the controller into its shutdown state, turning off both Q1 and Q2. At low load current, the module works in continuous current mode by default to achieve minimum output voltage ripple.

When DRV_{CC} pin is connected to $INTV_{CC}$ an integrated 5V linear regulator powers the internal gate drivers. If a 5V external bias supply is applied on the DRV_{CC} pin, then an efficiency improvement will occur due to the reduced power loss in the internal linear regulator. This is especially true at the higher input voltage range.

The LTM4603 has a very accurate differential remote sense amplifier with very low offset. This provides for very accurate remote sense voltage measurement. The MPGM pin, MARG0 pin and MARG1 pin are used to support voltage margining, where the percentage of margin is programmed by the MPGM pin, and the MARG0 and MARG1 select margining.

The PLLIN pin provides frequency synchronization of the device to an external clock. The TRACK/SS pin is used for power supply tracking and soft-start programming.

APPLICATIONS INFORMATION

The typical LTM4603 application circuit is shown in Figure 18. External component selection is primarily determined by the maximum load current and output voltage. Refer to Table 2 for specific external capacitor requirements for a particular application.

V_{IN} to V_{OUT} Step-Down Ratios

There are restrictions in the maximum V_{IN} and V_{OUT} step down ratio that can be achieved for a given input voltage. These constraints are shown in the Typical Performance Characteristics curves labeled V_{IN} to V_{OUT} Step-Down Ratio. Note that additional thermal derating may apply. See the Thermal Considerations and Output Current Derating section of this data sheet.

Output Voltage Programming and Margining

The PWM controller has an internal 0.6V reference voltage. As shown in the Block Diagram, a 1M and a 60.4k 0.5% internal feedback resistor connects V_{OUT} and V_{FB} pins together. The V_{OUT_LCL} pin is connected between the 1M and the 60.4k resistor. The 1M resistor is used to protect against an output overvoltage condition if the V_{OUT_LCL} pin is not connected to the output, or if the remote sense amplifier output is not connected to V_{OUT_LCL}. The output voltage will default to 0.6V. Adding a resistor R_{SET} from the V_{FB} pin to SGND pin programs the output voltage:

$$V_{OUT} = 0.6V \frac{60.4k + R_{SET}}{R_{SET}}$$

Table 1. R_{SET} Standard 1% Resistor Values vs V_{OUT}

| R _{SET} (kΩ) | Open | 60.4 | 40.2 | 30.1 | 25.5 | 19.1 | 13.3 | 8.25 |
|-----------------------|------|------|------|------|------|------|------|------|
| V _{OUT} (V) | 0.6 | 1.2 | 1.5 | 1.8 | 2 | 2.5 | 3.3 | 5 |

The MPGM pin programs a current that when multiplied by an internal 10k resistor sets up the 0.6V reference ± offset for margining. A 1.18V reference divided by the R_{PGM} resistor on the MPGM pin programs the current. Calculate V_{OUT(MARGIN)}:

$$V_{OUT(MARGIN)} = \frac{\%V_{OUT}}{100} \cdot V_{OUT}$$

where %V_{OUT} is the percentage of V_{OUT} you want to margin, and V_{OUT(MARGIN)} is the margin quantity in volts:

$$R_{PGM} = \frac{V_{OUT}}{0.6V} \cdot \frac{1.18V}{V_{OUT(MARGIN)}} \cdot 10k$$

where R_{PGM} is the resistor value to place on the MPGM pin to ground.

The output margining will be ± margining of the value. This is controlled by the MARG0 and MARG1 pins. See the truth table below:

| MARG1 | MARG0 | MODE |
|-------|-------|-------------|
| LOW | LOW | NO MARGIN |
| LOW | HIGH | MARGIN UP |
| HIGH | LOW | MARGIN DOWN |
| HIGH | HIGH | NO MARGIN |

Input Capacitors

LTM4603 module should be connected to a low AC impedance DC source. Input capacitors are required to be placed adjacent to the module. In Figure 18, the 10μF ceramic input capacitors are selected for their ability to handle the large RMS current into the converter. An input bulk capacitor of 100μF is optional. This 100μF capacitor is only needed if the input source impedance is compromised by long inductive leads or traces.

For a buck converter, the switching duty-cycle can be estimated as:

$$D = \frac{V_{OUT}}{V_{IN}}$$

Without considering the inductor current ripple, the RMS current of the input capacitor can be estimated as:

$$I_{CIN(RMS)} = \frac{I_{OUT(MAX)}}{\eta\%} \cdot \sqrt{D \cdot (1-D)}$$

In the above equation, η% is the estimated efficiency of the power module. C_{IN} can be a switcher-rated electrolytic aluminum capacitor, OS-CON capacitor or high volume ceramic capacitor. Note the capacitor ripple current ratings are often based on temperature and hours of life. This makes it advisable to properly derate the input capacitor,

APPLICATIONS INFORMATION

or choose a capacitor rated at a higher temperature than required. Always contact the capacitor manufacturer for derating requirements.

In Figure 18, the $10\mu\text{F}$ ceramic capacitors are together used as a high frequency input decoupling capacitor. In a typical 6A output application, two very low ESR, X5R or X7R, $10\mu\text{F}$ ceramic capacitors are recommended. These decoupling capacitors should be placed directly adjacent to the module input pins in the PCB layout to minimize the trace inductance and high frequency AC noise. Each $10\mu\text{F}$ ceramic is typically good for 2A to 3A of RMS ripple current. Refer to your ceramics capacitor catalog for the RMS current ratings.

Multiphase operation with multiple LTM4603 devices in parallel will lower the effective input RMS ripple current due to the interleaving operation of the regulators. Application Note 77 provides a detailed explanation. Refer to Figure 2 for the input capacitor ripple current requirement as a function of the number of phases. The figure provides a ratio of RMS ripple current to DC load current as a function of duty cycle and the number of paralleled phases. Pick the corresponding duty cycle and the number of phases to arrive at the correct ripple current value. For example, the 2-phase parallel LTM4603 design provides 10A at 2.5V output from a 12V input. The duty cycle is $DC = 2.5\text{V}/12\text{V} = 0.21$. The 2-phase curve has a ratio of ~ 0.25 for a duty cycle of 0.21. This 0.25 ratio of RMS ripple current to a DC load current of 10A equals $\sim 2.5\text{A}$ of input RMS ripple current for the external input capacitors.

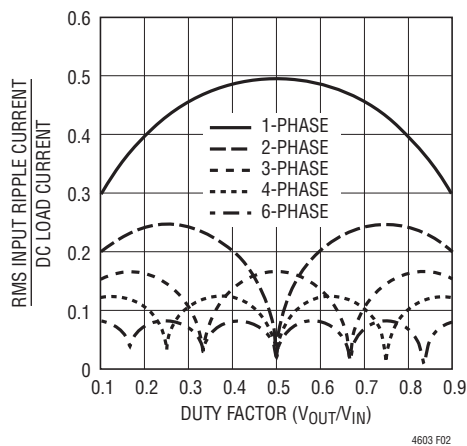

Figure 2. Normalized Input RMS Ripple Current vs Duty Factor for One to Six Modules (Phases)

Output Capacitors

The LTM4603 is designed for low output voltage ripple. The bulk output capacitors defined as C_{OUT} are chosen with low enough effective series resistance (ESR) to meet the output voltage ripple and transient requirements. C_{OUT} can be a low ESR tantalum capacitor, a low ESR polymer capacitor or a ceramic capacitor. The typical capacitance is $200\mu\text{F}$ if all ceramic output capacitors are used. Additional output filtering may be required by the system designer, if further reduction of output ripple or dynamic transient spike is required. Table 2 shows a matrix of different output voltages and output capacitors to minimize the voltage droop and overshoot during a $2.5\text{A}/\mu\text{s}$ transient. The table optimizes total equivalent ESR and total bulk capacitance to maximize transient performance.

Multiphase operation with multiple LTM4603 devices in parallel will lower the effective output ripple current due to the interleaving operation of the regulators. For example, each LTM4603's inductor current of a 12V to 2.5V multiphase design can be read from the "Inductor Ripple Current vs Duty Cycle" graph (Figure 3). The large ripple current at low duty cycle and high output voltage can be reduced by adding an external resistor from f_{SET} to ground which increases the frequency. If we choose the duty cycle of $DC = 2.5\text{V}/12\text{V} = 0.21$, the inductor ripple current for 2.5V output at 21% duty cycle is $\sim 3\text{A}$ in Figure 3.

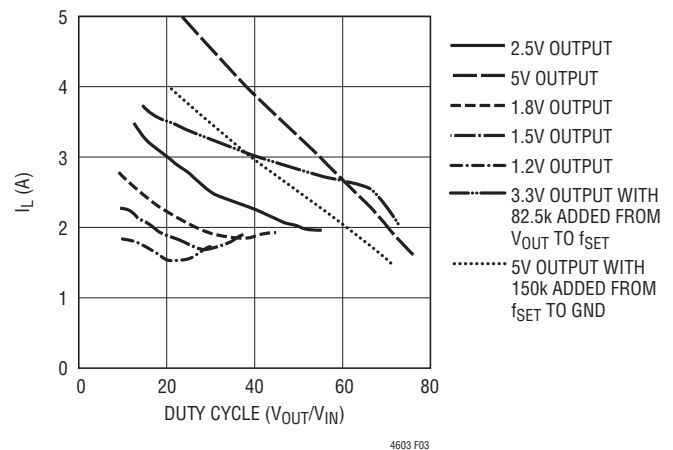

Figure 3. Inductor Ripple Current vs Duty Cycle

APPLICATIONS INFORMATION

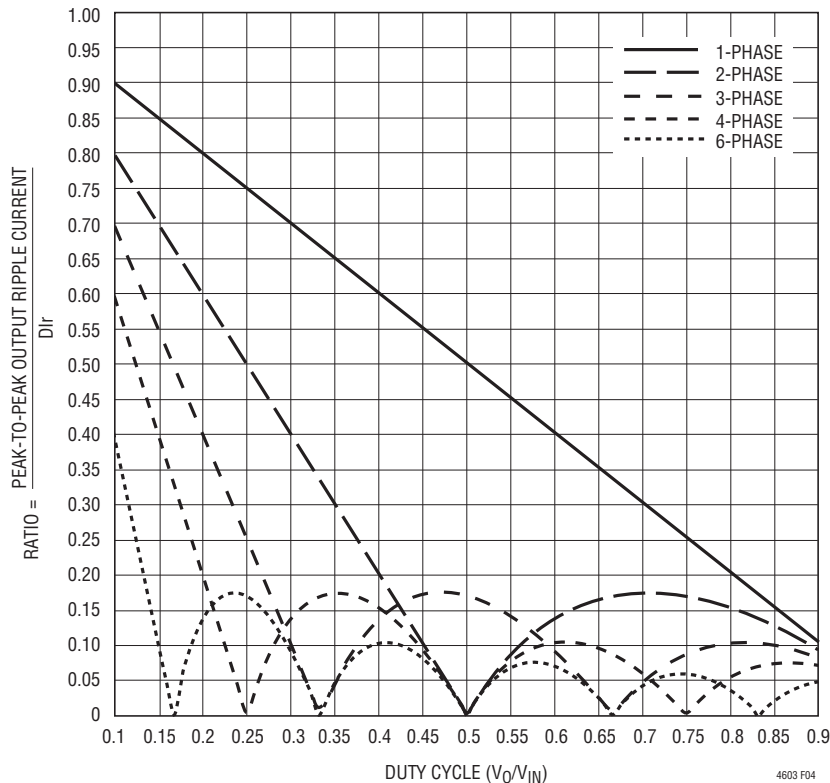

Figure 4. Normalized Output Ripple Current vs Duty Cycle, $D_{lr} = V_O T / L_I$

Figure 4 provides a ratio of peak-to-peak output ripple current to the inductor current as a function of duty cycle and the number of paralleled phases. Pick the corresponding duty cycle and the number of phases to arrive at the correct output ripple current ratio value. If a 2-phase operation is chosen at a duty cycle of 21%, then 0.6 is the ratio. This 0.6 ratio of output ripple current to inductor ripple of 3A equals 8A of effective output ripple current. Refer to Application Note 77 for a detailed explanation of output ripple current reduction as a function of paralleled phases.

The output voltage ripple has two components that are related to the amount of bulk capacitance and effective series resistance (ESR) of the output bulk capacitance. Therefore, the output voltage ripple can be calculated with the known effective output ripple current. The equation: $\Delta V_{OUT(P-P)} \approx (\Delta I_L / (8 \cdot f \cdot m \cdot C_{OUT}) + ESR \cdot \Delta I_L)$, where f is frequency and m is the number of parallel phases. This calculation process can be easily fulfilled using our Linear Technology μ Module Design Tool.

Fault Conditions: Current Limit and Overcurrent Foldback

The LTM4603 has a current mode controller, which inherently limits the cycle-by-cycle inductor current not only in steady-state operation, but also in transient.

To further limit current in the event of an overload condition, the LTM4603 provides foldback current limiting. If the output voltage falls by more than 50%, then the maximum output current is progressively lowered to about one sixth of its full current limit value.

Soft-Start and Tracking

The TRACK/SS pin provides a means to either soft-start the regulator or track it to a different power supply. A capacitor on this pin will program the ramp rate of the output voltage. A 1.5 μ A current source will charge up the external soft-start capacitor to 80% of the 0.6V internal voltage reference minus any margin delta. This will control

APPLICATIONS INFORMATION

the ramp of the internal reference and the output voltage. The total soft-start time can be calculated as:

$$t_{\text{SOFTSTART}} = 0.8 \cdot (0.6\text{V} - V_{\text{OUT(MARGIN)}}) \cdot \frac{C_{\text{SS}}}{1.5\mu\text{A}}$$

When the RUN pin falls below 1.5V, then the SS pin is reset to allow for proper soft-start control when the regulator is enabled again. Current foldback and force continuous mode are disabled during the soft-start process. The soft-start function can also be used to control the output ramp up time, so that another regulator can be easily tracked to it.

Output Voltage Tracking

Output voltage tracking can be programmed externally using the TRACK/SS pin. The output can be tracked up and down with another regulator. The master regulator's output is divided down with an external resistor divider that is the same as the slave regulator's feedback divider. Figure 5 shows an example of coincident tracking. Ratiometric modes of tracking can be achieved by selecting different resistor values to change the output tracking ratio. The master output must be greater than the slave output for the tracking to work. Figure 6 shows the coincident output tracking characteristics.

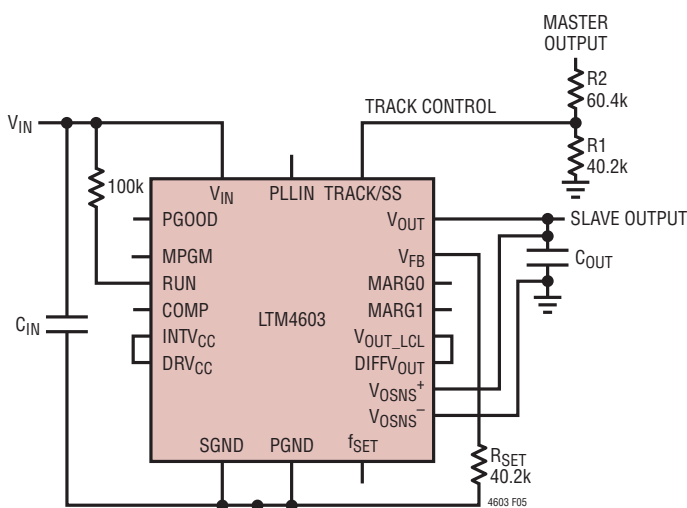

Figure 5. Coincident Tracking

Run Enable

The RUN pin is used to enable the power module. The pin has an internal 5.1V zener to ground. The pin can be driven with a logic input not to exceed 5V.

The RUN pin can also be used as an undervoltage lock out (UVLO) function by connecting a resistor divider from the input supply to the RUN pin:

$$V_{\text{UVLO}} = \frac{R1+R2}{R2} \cdot 1.5\text{V}$$

See the Simplified Block Diagram (Figure 1).

Power Good

The PGOOD pin is an open-drain pin that can be used to monitor valid output voltage regulation. This pin monitors a $\pm 10\%$ window around the regulation point and tracks with margining.

COMP Pin

This pin is the external compensation pin. The module has already been internally compensated for most output voltages. Table 2 is provided for most application requirements. A spice model will be provided for other control loop optimization.

PLLIN

The power module has a phase-locked loop comprised of an internal voltage controlled oscillator and a phase detector. This allows the internal top MOSFET turn-on to be locked

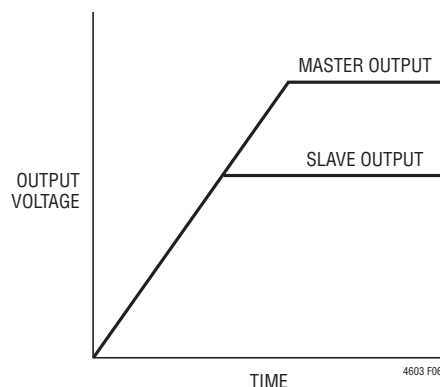

Figure 6. Coincident Output Tracking Characteristics

4603fa

APPLICATIONS INFORMATION

to the rising edge of the external clock. The frequency range is $\pm 30\%$ around the operating frequency of 1MHz. A pulse detection circuit is used to detect a clock on the PLLIN pin to turn on the phase lock loop. The pulse width of the clock has to be at least 400ns and 2V in amplitude. During the start-up of the regulator, the phase-lock loop function is disabled.

INTV_{CC} and DRV_{CC} Connection

An internal low dropout regulator produces an internal 5V supply that powers the control circuitry and DRV_{CC} for driving the internal power MOSFETs. Therefore, if the system does not have a 5V power rail, the LTM4603 can be directly powered by V_{IN}. The gate driver current through the LDO is about 20mA. The internal LDO power dissipation can be calculated as:

$$P_{LDO_LOSS} = 20\text{mA} \cdot (V_{IN} - 5\text{V})$$

The LTM4603 also provides the external gate driver voltage pin DRV_{CC}. If there is a 5V rail in the system, it is recommended to connect DRV_{CC} pin to the external 5V rail. This is especially true for higher input voltages. Do not apply more than 6V to the DRV_{CC} pin. A 5V output can be used to power the DRV_{CC} pin with an external circuit as shown in Figure 16.

Parallel Operation of the Module

The LTM4603 device is an inherently current mode controlled device. Parallel modules will have very good current

sharing. This will balance the thermals on the design. The voltage feedback equation changes with the variable n as modules are paralleled:

$$V_{OUT} = 0.6\text{V} \frac{\frac{60.4\text{k}}{n} + R_{FB}}{R_{FB}}$$

n is the number of paralleled modules.

Thermal Considerations and Output Current Derating

The power loss curves in Figures 7 and 8 can be used in coordination with the load current derating curves in Figures 9 to 12, and Figures 13 to 14 for calculating an approximate θ_{JA} for the module with various heat sinking methods. Thermal models are derived from several temperature measurements at the bench and thermal modeling analysis. Thermal Application Note 103 provides a detailed explanation of the analysis for the thermal models and the derating curves. Tables 3 and 4 provide a summary of the equivalent θ_{JA} for the noted conditions. These equivalent θ_{JA} parameters are correlated to the measured values, and are improved with air flow. The case temperature is maintained at 100°C or below for the derating curves. This allows for 4W maximum power dissipation in the total module with top and bottom heatsinking, and 2W power dissipation through the top of the module with an approximate θ_{JC} between 6°C/W to 9°C/W. This equates to a total of 124°C at the junction of the device.

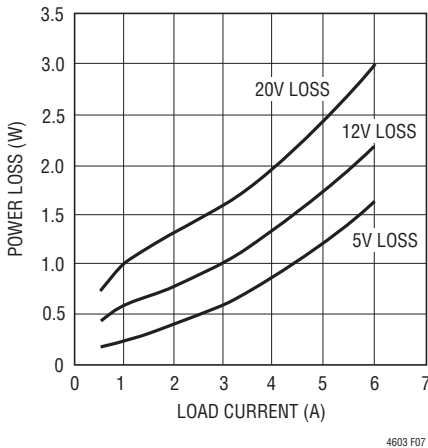

Figure 7. 1.5V Power Loss

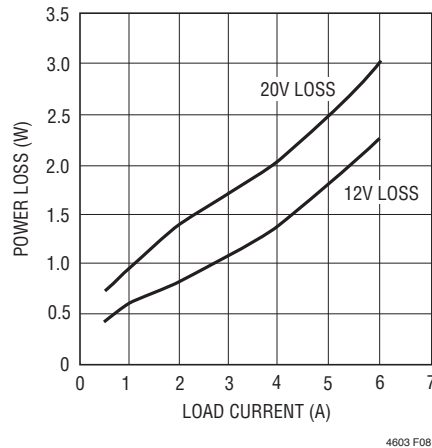

Figure 8. 3.3V Power Loss

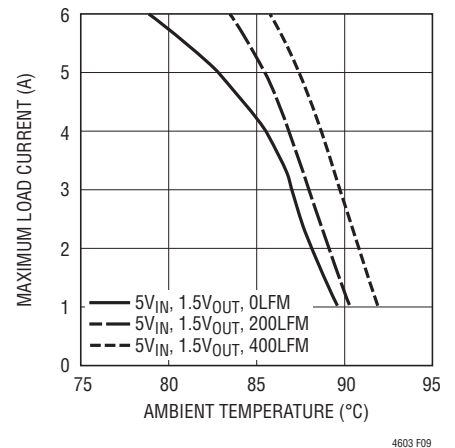

Figure 9. No Heat Sink 5V_{IN}

APPLICATIONS INFORMATION

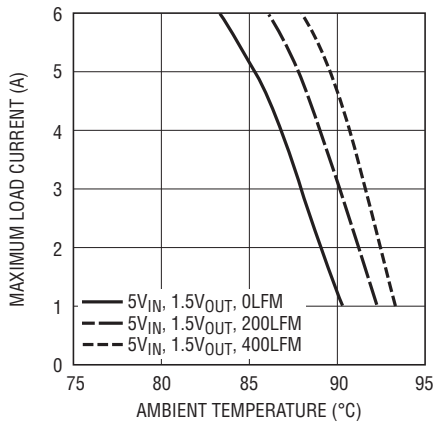

Figure 10. BGA Heat Sink 5V_{IN}

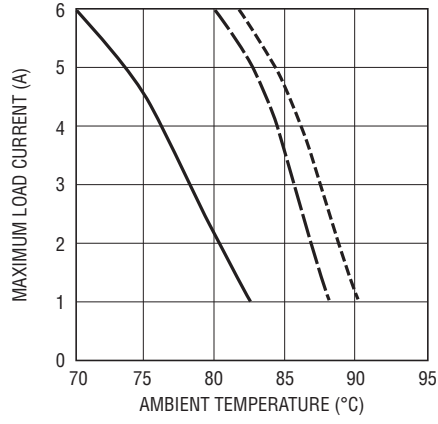

Figure 11. No Heat Sink 12V_{IN}

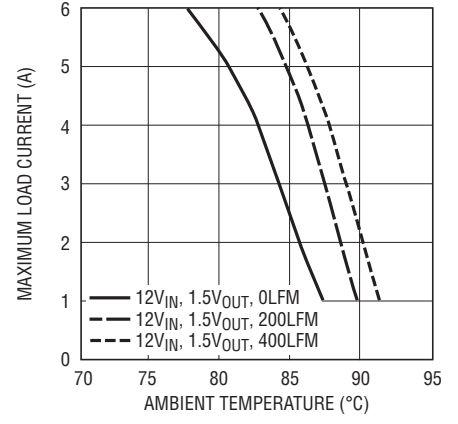

Figure 12. BGA Heat Sink 12V_{IN}

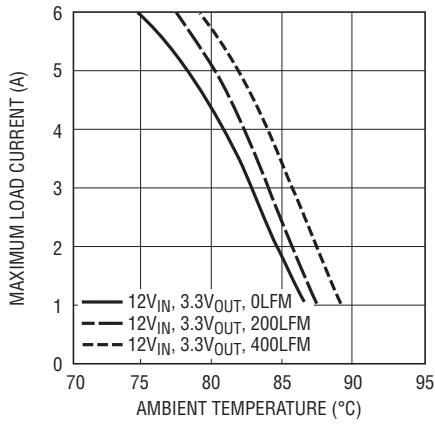

Figure 13. 12V_{IN}, 3.3V_{OUT} No Heat Sink

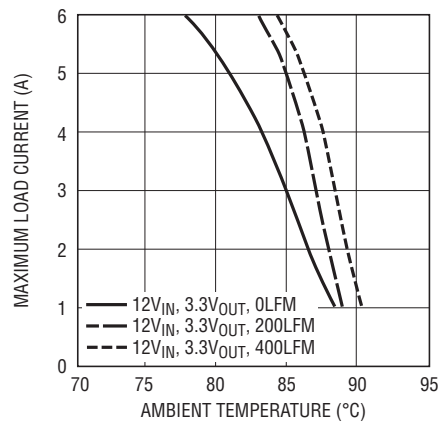

Figure 14. 12V_{IN}, 3.3V_{OUT} BGA Heat Sink

APPLICATIONS INFORMATION

Table 2. Output Voltage Response Versus Component Matrix (Refer to Figure 18)

TYPICAL MEASURED VALUES

| C _{OUT1} VENDORS | PART NUMBER | C _{OUT2} VENDORS | PART NUMBER |
|---------------------------|---------------------------------------|---------------------------|---------------------------------|
| TAIYO YUDEN | JMK316BJ226ML-T501 (22 μ F, 6.3V) | SANYO POSCAP | 6TPE220MIL (220 μ F, 6.3V) |
| TAIYO YUDEN | JMK325BJ476MM-T (47 μ F, 6.3V) | SANYO POSCAP | 2R5TPE330M9 (330 μ F, 2.5V) |
| TDK | C3225X5R0J476M (47 μ F, 6.3V) | SANYO POSCAP | 4TPE330MCL (330 μ F, 4V) |

| V _{OUT} (V) | C _{IN} (CERAMIC) | C _{IN} (BULK) | C _{OUT1} (CERAMIC) | C _{OUT2} (BULK) | V _{IN} (V) | DROOP (mV) | PEAK TO PEAK (mV) | RECOVERY TIME (μ s) | LOAD STEP (A/ μ s) | R _{SET} (k Ω) |
|----------------------|---------------------------|------------------------|-----------------------------|--------------------------|---------------------|------------|-------------------|--------------------------|------------------------|--------------------------------|
| 1.2 | 2 \times 10 μ F 25V | 150 μ F 35V | 1 \times 22 μ F 6.3V | 330 μ F 4V | 5 | 34 | 68 | 30 | 3 | 60.4 |
| 1.2 | 2 \times 10 μ F 25V | 150 μ F 35V | 1 \times 47 μ F 6.3V | 330 μ F 2.5V | 5 | 22 | 40 | 26 | 3 | 60.4 |
| 1.2 | 2 \times 10 μ F 25V | 150 μ F 35V | 2 \times 47 μ F 6.3V | 220 μ F 6.3V | 5 | 20 | 40 | 24 | 3 | 60.4 |
| 1.2 | 2 \times 10 μ F 25V | 150 μ F 35V | 4 \times 47 μ F 6.3V | NONE | 5 | 32 | 60 | 18 | 3 | 60.4 |
| 1.2 | 2 \times 10 μ F 25V | 150 μ F 35V | 1 \times 22 μ F 6.3V | 330 μ F 4V | 12 | 34 | 68 | 30 | 3 | 60.4 |
| 1.2 | 2 \times 10 μ F 25V | 150 μ F 35V | 1 \times 47 μ F 6.3V | 330 μ F 2.5V | 12 | 22 | 40 | 26 | 3 | 60.4 |
| 1.2 | 2 \times 10 μ F 25V | 150 μ F 35V | 2 \times 47 μ F 6.3V | 220 μ F 6.3V | 12 | 20 | 39 | 24 | 3 | 60.4 |
| 1.2 | 2 \times 10 μ F 25V | 150 μ F 35V | 4 \times 47 μ F 6.3V | NONE | 12 | 29.5 | 55 | 18 | 3 | 60.4 |
| 1.5 | 2 \times 10 μ F 25V | 150 μ F 35V | 1 \times 22 μ F 6.3V | 330 μ F 4V | 5 | 35 | 70 | 30 | 3 | 40.2 |
| 1.5 | 2 \times 10 μ F 25V | 150 μ F 35V | 1 \times 47 μ F 6.3V | 330 μ F 2.5V | 5 | 25 | 48 | 30 | 3 | 40.2 |
| 1.5 | 2 \times 10 μ F 25V | 150 μ F 35V | 2 \times 47 μ F 6.3V | 220 μ F 6.3V | 5 | 24 | 47.5 | 26 | 3 | 40.2 |
| 1.5 | 2 \times 10 μ F 25V | 150 μ F 35V | 4 \times 47 μ F 6.3V | NONE | 5 | 36 | 68 | 26 | 3 | 40.2 |
| 1.5 | 2 \times 10 μ F 25V | 150 μ F 35V | 1 \times 22 μ F 6.3V | 330 μ F 4V | 12 | 35 | 70 | 30 | 3 | 40.2 |
| 1.5 | 2 \times 10 μ F 25V | 150 μ F 35V | 1 \times 47 μ F 6.3V | 330 μ F 2.5V | 12 | 25 | 48 | 30 | 3 | 40.2 |
| 1.5 | 2 \times 10 μ F 25V | 150 μ F 35V | 2 \times 47 μ F 6.3V | 220 μ F 6.3V | 12 | 24 | 45 | 26 | 3 | 40.2 |
| 1.5 | 2 \times 10 μ F 25V | 150 μ F 35V | 4 \times 47 μ F 6.3V | NONE | 12 | 32.6 | 61.9 | 26 | 3 | 40.2 |
| 1.8 | 2 \times 10 μ F 25V | 150 μ F 35V | 1 \times 22 μ F 6.3V | 330 μ F 4V | 5 | 38 | 76 | 37 | 3 | 30.1 |
| 1.8 | 2 \times 10 μ F 25V | 150 μ F 35V | 1 \times 47 μ F 6.3V | 330 μ F 2.5V | 5 | 29.5 | 57.5 | 30 | 3 | 30.1 |
| 1.8 | 2 \times 10 μ F 25V | 150 μ F 35V | 2 \times 47 μ F 6.3V | 220 μ F 6.3V | 5 | 28 | 55 | 26 | 3 | 30.1 |
| 1.8 | 2 \times 10 μ F 25V | 150 μ F 35V | 4 \times 47 μ F 6.3V | NONE | 5 | 43 | 80 | 26 | 3 | 30.1 |
| 1.8 | 2 \times 10 μ F 25V | 150 μ F 35V | 1 \times 22 μ F 6.3V | 330 μ F 4V | 12 | 38 | 76 | 37 | 3 | 30.1 |
| 1.8 | 2 \times 10 μ F 25V | 150 μ F 35V | 1 \times 47 μ F 6.3V | 330 μ F 2.5V | 12 | 28 | 55 | 30 | 3 | 30.1 |
| 1.8 | 2 \times 10 μ F 25V | 150 μ F 35V | 2 \times 47 μ F 6.3V | 220 μ F 6.3V | 12 | 27 | 52 | 26 | 3 | 30.1 |
| 1.8 | 2 \times 10 μ F 25V | 150 μ F 35V | 4 \times 47 μ F 6.3V | NONE | 12 | 36.4 | 70 | 26 | 3 | 30.1 |
| 2.5 | 2 \times 10 μ F 25V | 150 μ F 35V | 1 \times 22 μ F 6.3V | 330 μ F 4V | 5 | 38 | 78 | 40 | 3 | 19.1 |
| 2.5 | 2 \times 10 μ F 25V | 150 μ F 35V | 1 \times 47 μ F 6.3V | 330 μ F 4V | 5 | 37.6 | 74 | 34 | 3 | 19.1 |
| 2.5 | 2 \times 10 μ F 25V | 150 μ F 35V | 2 \times 47 μ F 6.3V | 220 μ F 6.3V | 5 | 39.5 | 78.1 | 28 | 3 | 19.1 |
| 2.5 | 2 \times 10 μ F 25V | 150 μ F 35V | 4 \times 47 μ F 6.3V | NONE | 5 | 66 | 119 | 12 | 3 | 19.1 |
| 2.5 | 2 \times 10 μ F 25V | 150 μ F 35V | 1 \times 22 μ F 6.3V | 330 μ F 4V | 12 | 38 | 78 | 40 | 3 | 19.1 |
| 2.5 | 2 \times 10 μ F 25V | 150 μ F 35V | 1 \times 47 μ F 6.3V | 330 μ F 4V | 12 | 34.5 | 66.3 | 34 | 3 | 19.1 |
| 2.5 | 2 \times 10 μ F 25V | 150 μ F 35V | 2 \times 47 μ F 6.3V | 220 μ F 6.3V | 12 | 35.8 | 68.8 | 28 | 3 | 19.1 |
| 2.5 | 2 \times 10 μ F 25V | 150 μ F 35V | 4 \times 47 μ F 6.3V | NONE | 12 | 50 | 98 | 18 | 3 | 19.1 |
| 3.3 | 2 \times 10 μ F 25V | 150 μ F 35V | 1 \times 22 μ F 6.3V | 330 μ F 4V | 7 | 42 | 86 | 40 | 3 | 13.3 |
| 3.3 | 2 \times 10 μ F 25V | 150 μ F 35V | 1 \times 47 μ F 6.3V | 330 μ F 4V | 7 | 47 | 89 | 32 | 3 | 13.3 |
| 3.3 | 2 \times 10 μ F 25V | 150 μ F 35V | 2 \times 47 μ F 6.3V | 220 μ F 6.3V | 7 | 50 | 94 | 28 | 3 | 13.3 |
| 3.3 | 2 \times 10 μ F 25V | 150 μ F 35V | 4 \times 47 μ F 6.3V | NONE | 7 | 75 | 141 | 14 | 3 | 13.3 |
| 3.3 | 2 \times 10 μ F 25V | 150 μ F 35V | 1 \times 22 μ F 6.3V | 330 μ F 4V | 12 | 42 | 86 | 40 | 3 | 13.3 |
| 3.3 | 2 \times 10 μ F 25V | 150 μ F 35V | 1 \times 47 μ F 6.3V | 330 μ F 4V | 12 | 47 | 88 | 32 | 3 | 13.3 |
| 3.3 | 2 \times 10 μ F 25V | 150 μ F 35V | 2 \times 47 μ F 6.3V | 220 μ F 6.3V | 12 | 50 | 94 | 28 | 3 | 13.3 |
| 3.3 | 2 \times 10 μ F 25V | 150 μ F 35V | 4 \times 47 μ F 6.3V | NONE | 12 | 69 | 131 | 22 | 3 | 13.3 |
| 5 | 2 \times 10 μ F 25V | 150 μ F 35V | 4 \times 47 μ F 6.3V | NONE | 15 | 110 | 215 | 20 | 3 | 8.25 |
| 5 | 2 \times 10 μ F 25V | 150 μ F 35V | 4 \times 47 μ F 6.3V | NONE | 20 | 110 | 217 | 20 | 3 | 8.25 |

APPLICATIONS INFORMATION

Table 3. 1.5V Output

| DERATING CURVE | V _{IN} (V) | POWER LOSS CURVE | AIR FLOW (LFM) | HEAT SINK | θ _{JA} (°C/W) |
|----------------|---------------------|------------------|----------------|---------------|------------------------|
| Figures 9, 11 | 5, 12 | Figure 7 | 0 | None | 15.2 |
| Figures 9, 11 | 5, 12 | Figure 7 | 200 | None | 14 |
| Figures 9, 11 | 5, 12 | Figure 7 | 400 | None | 12 |
| Figures 10, 12 | 5, 12, 20 | Figure 7 | 0 | BGA Heat Sink | 13.9 |
| Figures 10, 12 | 5, 12, 20 | Figure 7 | 200 | BGA Heat Sink | 11.3 |
| Figures 10, 12 | 5, 12, 20 | Figure 7 | 400 | BGA Heat Sink | 10.25 |

Table 4. 3.3V Output

| DERATING CURVE | V _{IN} (V) | POWER LOSS CURVE | AIR FLOW (LFM) | HEAT SINK | θ _{JA} (°C/W) |
|----------------|---------------------|------------------|----------------|---------------|------------------------|
| Figure 13 | 12 | Figure 8 | 0 | None | 15.2 |
| Figure 13 | 12 | Figure 8 | 200 | None | 14.6 |
| Figure 13 | 12 | Figure 8 | 400 | None | 13.4 |
| Figure 14 | 12 | Figure 8 | 0 | BGA Heat Sink | 13.9 |
| Figure 14 | 12 | Figure 8 | 200 | BGA Heat Sink | 11.1 |
| Figure 14 | 12 | Figure 8 | 400 | BGA Heat Sink | 10.5 |

Heat Sink Manufacturer

| | | |
|-----------------------|------------------------|---------------------|
| Wakefield Engineering | Part No: 20069 | Phone: 603-635-2800 |
| Aavid Thermalloy | Part No: 375424B00034G | Phone: 603-224-9988 |

APPLICATIONS INFORMATION

Safety Considerations

The LTM4603 modules do not provide isolation from V_{IN} to V_{OUT} . There is no internal fuse. If required, a slow blow fuse with a rating twice the maximum input current needs to be provided to protect each unit from catastrophic failure.

Layout Checklist/Example

The high integration of LTM4603 makes the PCB board layout very simple and easy. However, to optimize its electrical and thermal performance, some layout considerations are still necessary.

- Use large PCB copper areas for high current path, including V_{IN} , PGND and V_{OUT} . It helps to minimize the PCB conduction loss and thermal stress.
- Place high frequency ceramic input and output capacitors next to the V_{IN} , PGND and V_{OUT} pins to minimize high frequency noise.
- Place a dedicated power ground layer underneath the unit.
- To minimize the via conduction loss and reduce module thermal stress, use multiple vias for interconnection between top layer and other power layers.

- Do not put vias directly on pads.
- If vias are placed onto the pads, the the vias must be capped.
- Interstitial via placement can also be used if necessary.
- Use a separated SGND ground copper area for components connected to signal pins. Connect the SGND to PGND underneath the unit.

Figure 15 gives a good example of the recommended layout.

Frequency Adjustment

The LTM4603 is designed to typically operate at 1MHz across most input conditions. The f_{SET} pin is typically left open or decoupled with an optional 1000pF capacitor. The switching frequency has been optimized for maintaining constant output ripple noise over most operating ranges. The 1MHz switching frequency and the 400ns minimum off time can limit operation at higher duty cycles like 5V to 3.3V, and produce excessive inductor ripple currents for lower duty cycle applications like 20V to 5V. The 5V and 3.3V drop out curves are modified by adding an external resistor on the f_{SET} pin to allow for lower input voltage operation, or higher input voltage operation.

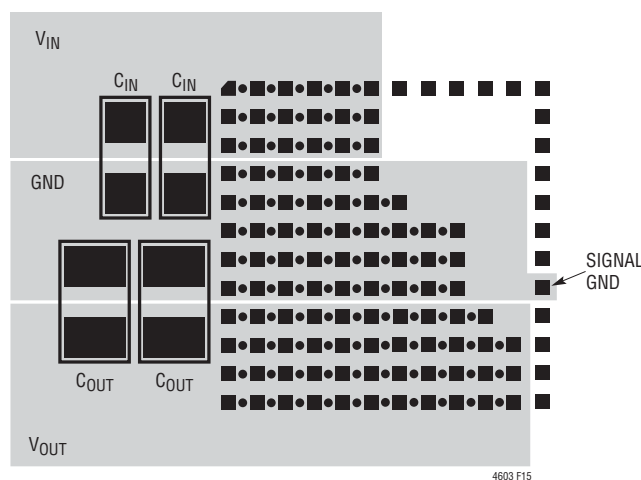

Figure 15. Recommended Layout

APPLICATIONS INFORMATION

Example for 5V Output

LTM4603 minimum on-time = 100ns;

$$t_{ON} = ((4.8 \cdot 10\text{pf})/I_{fSET})$$

LTM4603 minimum off-time = 400ns; $t_{OFF} = t - t_{ON}$,
where $t = 1/\text{Frequency}$

$$\text{Duty Cycle} = t_{ON}/t \text{ or } V_{OUT}/V_{IN}$$

Equations for setting frequency:

$I_{fSET} = (V_{IN}/(3 \cdot R_{fSET}))$, for 20V operation, $I_{fSET} = 201\mu\text{A}$, $t_{ON} = ((4.8 \cdot 10\text{pF})/I_{fSET})$, $t_{ON} = 239\text{ns}$, where the internal R_{fSET} is 33.2k. $\text{Frequency} = (V_{OUT}/(V_{IN} \cdot t_{ON})) = (5\text{V}/(20 \cdot 239\text{ns})) \sim 1\text{MHz}$. The inductor ripple current begins to get high at the higher input voltages due to a larger voltage across the inductor. This is noted in the “Inductor Ripple Current vs Duty Cycle” graph at ~5A at 25% duty cycle. The inductor ripple current can be lowered at the higher input voltages by adding an external resistor from f_{SET} to ground to increase the switching frequency. A 3A ripple current is chosen, and the total peak current is equal to 1/2 of the 3A ripple current plus the output current. The 5V output current is limited to 5A, so total peak current is less than 6.5A. This is below the 7A peak specified value. A 150k resistor is placed from f_{SET} to ground, and the parallel combination of 150k and 33.2k equates to 27.2k. The I_{fSET} calculation with 27.2k and 20V input voltage equals $245\mu\text{A}$. This equates to a t_{ON} of 196ns. This will increase the switching frequency from 1MHz to ~1.28MHz for the 20V to 5V conversion. The minimum on time is above 100ns at 20V input. Since the switching frequency is approximately constant over input and output conditions, then the lower input voltage range is limited to 10V for the 1.28MHz operation due to the 400ns minimum off time. Equation: $t_{ON} = (V_{OUT}/V_{IN}) \cdot (1/\text{Frequency})$ equates to a 382ns on time, and a 400ns off time. The “ V_{IN} to V_{OUT} Step-Down Ratio” curve reflects an operating range of 10V to 20V for 1.28MHz operation with a 150k resistor to ground, and an 8V to 16V operation for f_{SET} floating. These modifications are made to provide wider input voltage ranges for the 5V output designs while limiting the inductor ripple current, and maintaining the 400ns minimum off time.

Example for 3.3V Output

LTM4603 minimum on-time = 100ns;

$$t_{ON} = ((3.3 \cdot 10\text{pF})/I_{fSET})$$

LTM4603 minimum off-time = 400ns;
 $t_{OFF} = t - t_{ON}$, where $t = 1/\text{Frequency}$

$$\text{Duty Cycle (DC)} = t_{ON}/t \text{ or } V_{OUT}/V_{IN}$$

Equations for setting frequency:

$I_{fSET} = (V_{IN}/(3 \cdot R_{fSET}))$, for 20V operation, $I_{fSET} = 201\mu\text{A}$, $t_{ON} = ((3.3 \cdot 10\text{pF})/I_{fSET})$, $t_{ON} = 164\text{ns}$, where the internal R_{fSET} is 33.2k. $\text{Frequency} = (V_{OUT}/(V_{IN} \cdot t_{ON})) = (3.3\text{V}/(20 \cdot 164\text{ns})) \sim 1\text{MHz}$. The minimum on-time and minimum-off time are within specification at 164ns and 836ns. The 4.5V minimum input for converting 3.3V output will not meet the minimum off-time specification of 400ns. $t_{ON} = 733\text{ns}$, $\text{Frequency} = 1\text{MHz}$, $t_{OFF} = 267\text{ns}$.

Solution

Lower the switching frequency at lower input voltages to allow for higher duty cycles, and meet the 400ns minimum off-time at 4.5V input voltage. The off-time should be about 500ns with 100ns guard band. The duty cycle for $(3.3\text{V}/4.5) = \sim 73\%$. $\text{Frequency} = (1 - \text{DC})/t_{OFF}$ or $(1 - 0.73)/500\text{ns} = 540\text{kHz}$. The switching frequency needs to be lowered to 540kHz at 4.5V input. $t_{ON} = \text{DC}/\text{frequency}$, or $1.35\mu\text{s}$. The f_{SET} pin voltage compliance is 1/3 of V_{IN} , and the I_{fSET} current equates to $45\mu\text{A}$ with the internal 33.2k. The I_{fSET} current needs to be $24\mu\text{A}$ for 540kHz operation. A resistor can be placed from V_{OUT} to f_{SET} to lower the effective I_{fSET} current out of the f_{SET} pin to $24\mu\text{A}$. The f_{SET} pin is $4.5\text{V}/3 = 1.5\text{V}$ and $V_{OUT} = 3.3\text{V}$, therefore 82.5k will source $21\mu\text{A}$ into the f_{SET} node and lower the I_{fSET} current to $24\mu\text{A}$. This enables the 540kHz operation and the 4.5V to 20V input operation for down converting to 3.3V output. The frequency will scale from 540kHz to 1.2MHz over this input range. This provides for an effective output current of 5A over the input range.

APPLICATIONS INFORMATION

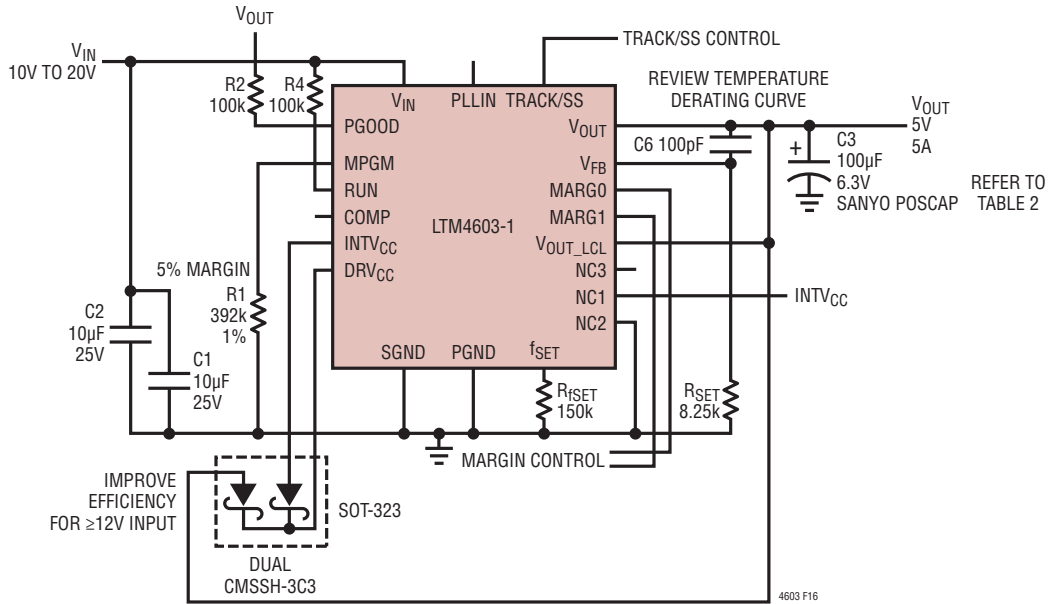

Figure 16. 5V at 5A Design Without Differential Amplifier

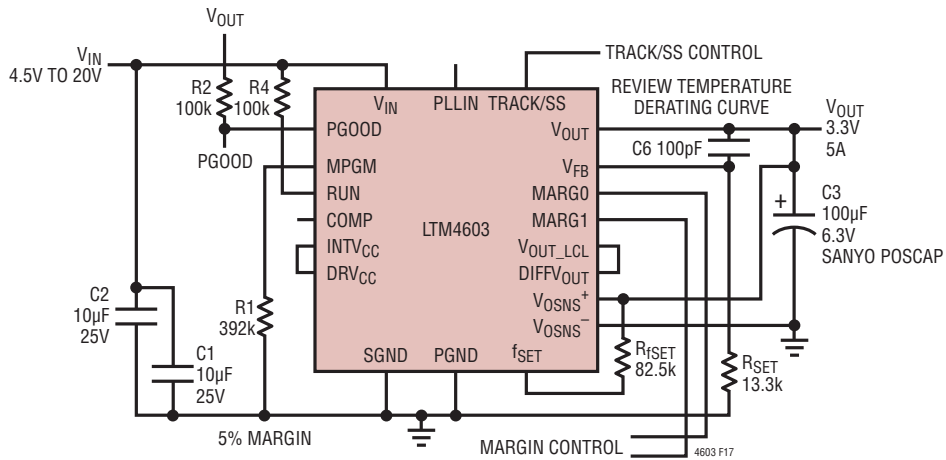

Figure 17. 3.3V at 5A Design

APPLICATIONS INFORMATION

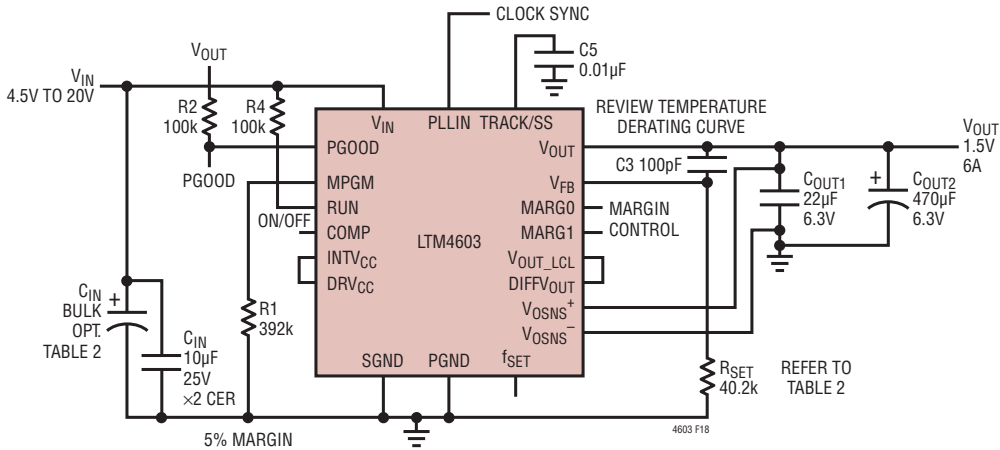
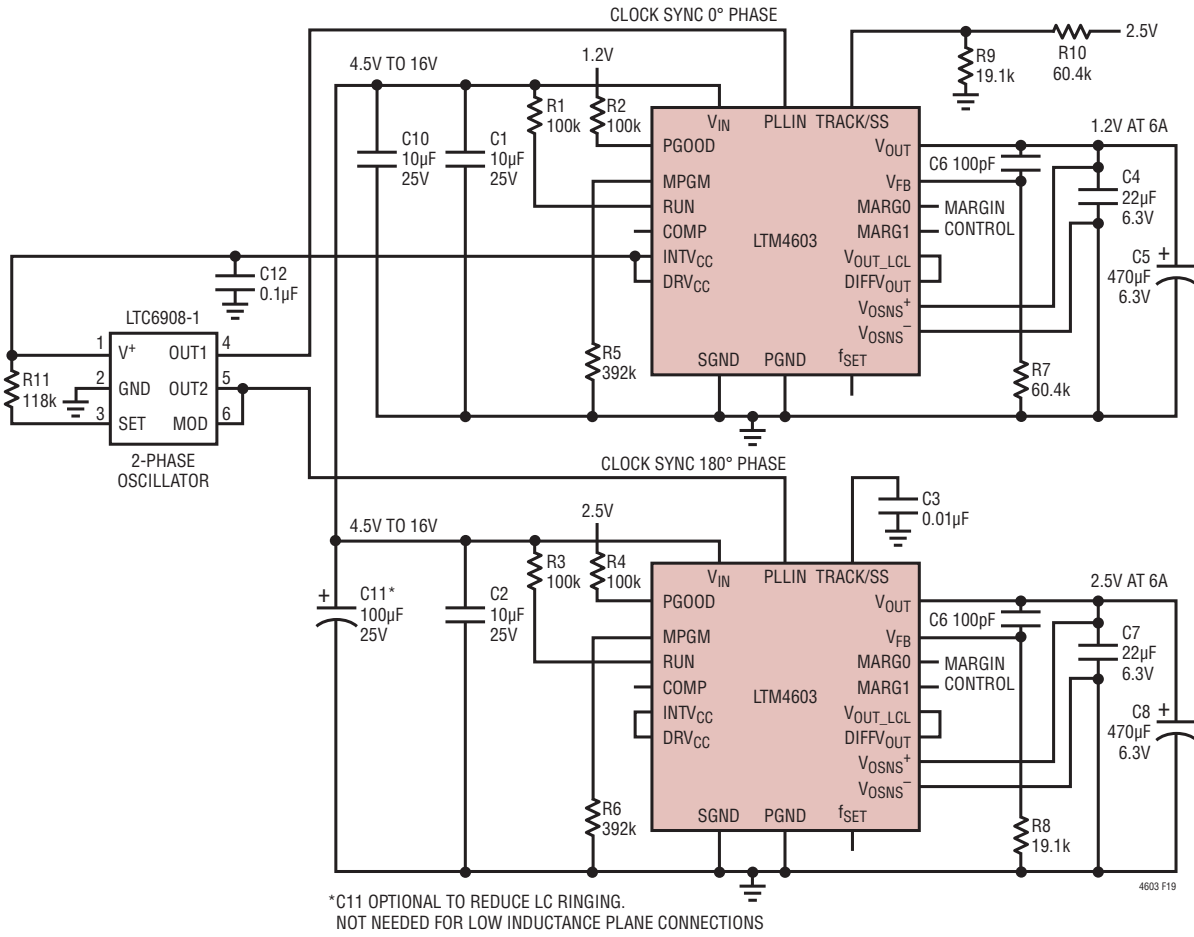

Figure 18. Typical 4.5V-20VIN, 1.5V at 6A Design



*C11 OPTIONAL TO REDUCE LC RINGING.
NOT NEEDED FOR LOW INDUCTANCE PLANE CONNECTIONS

Figure 19. 2-Phase, 2.5V and 1.2V at 6A with Tracking

TYPICAL APPLICATION

4-Phase, Four Outputs (3.3V, 2.5V, 1.8V and 1.5V) with Tracking

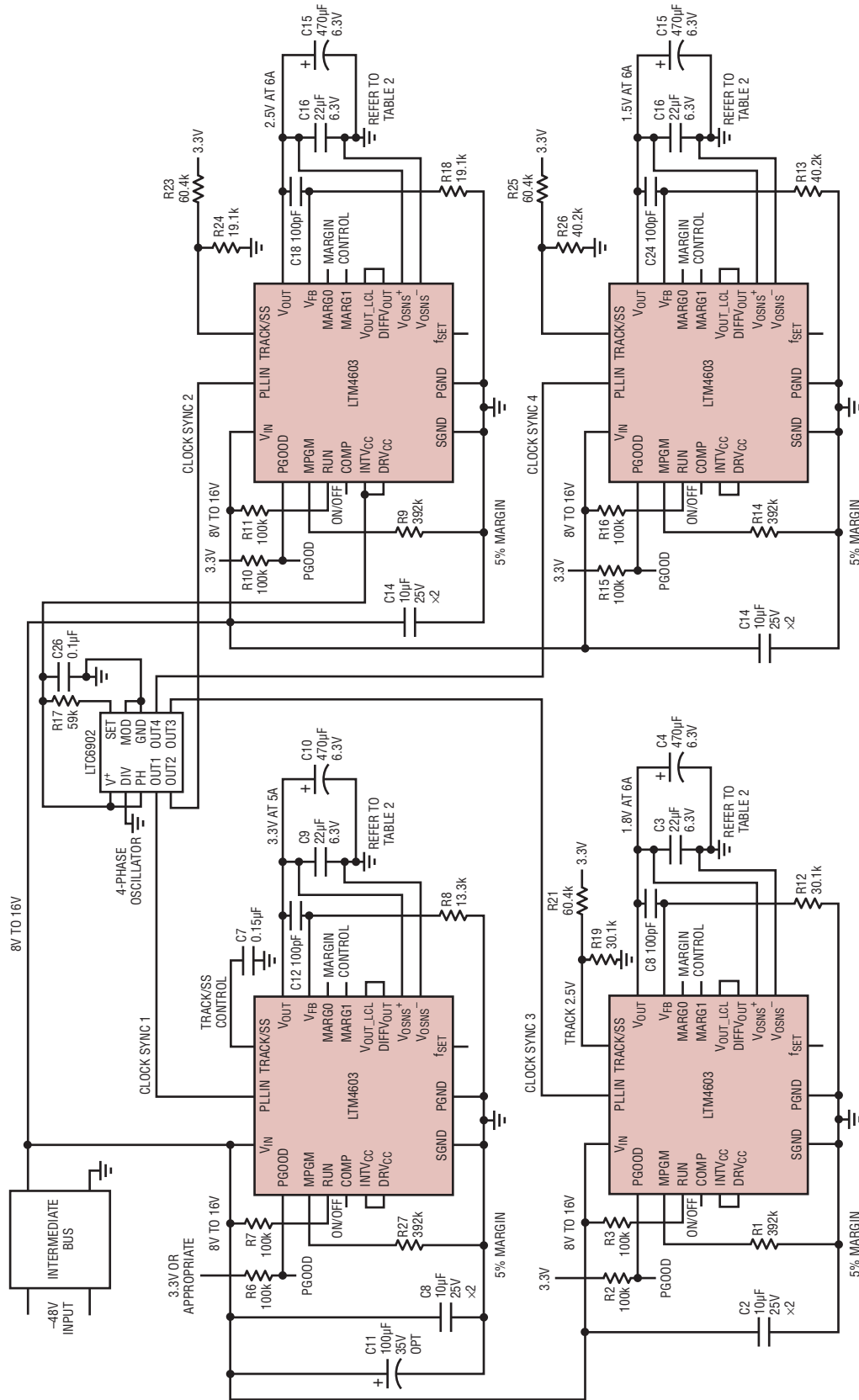

PACKAGE DESCRIPTION

LGA Package 118-Lead (15mm × 15mm)

(Reference LTC DWG # 05-08-1801 Rev 0)

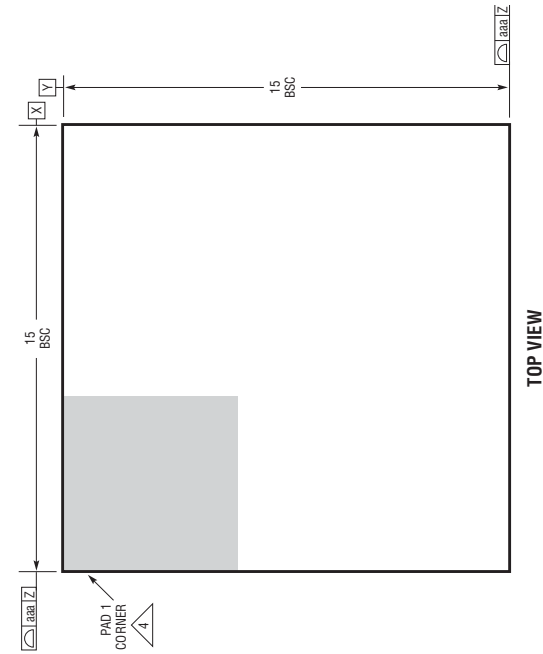

TOP VIEW

NOTES:

1. DIMENSIONING AND TOLERANCING PER ASME Y14.5M-1994
2. ALL DIMENSIONS ARE IN MILLIMETERS
3. LAND DESIGNATION PER JEDEC MO-222, SPP-010
4. DETAILS OF PAD #1 IDENTIFIER ARE OPTIONAL BUT MUST BE LOCATED WITHIN THE ZONE INDICATED. THE PAD #1 IDENTIFIER MAY BE EITHER A MOLD OR MARKED FEATURE
5. PRIMARY DATUM -Z- IS SEATING PLANE
6. THE TOTAL NUMBER OF PADS: 118

| SYMBOL | TOLERANCE |
|--------|-----------|
| aaa | 0.10 |
| bbb | 0.10 |
| eee | 0.03 |

LGA 118.0206 REV 0

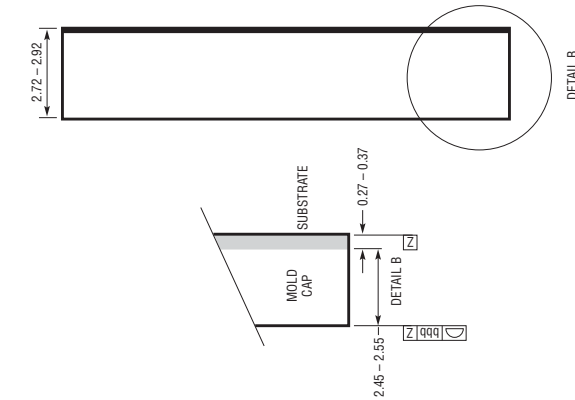

DETAIL B

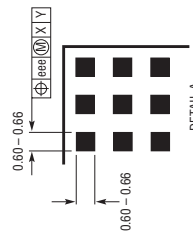

DETAIL A

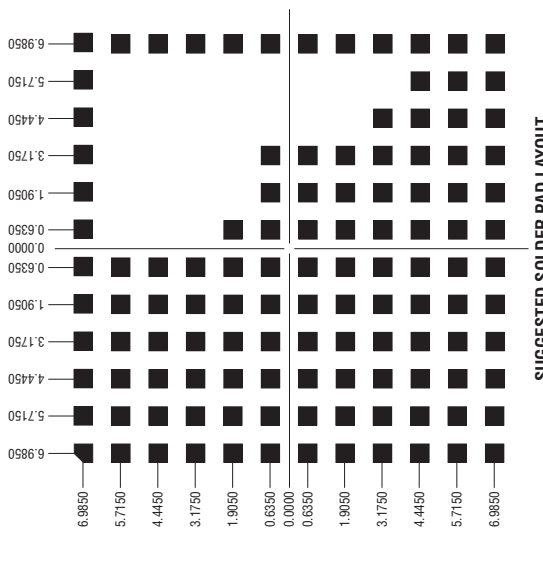

SUGGESTED SOLDER PAD LAYOUT
TOP VIEW

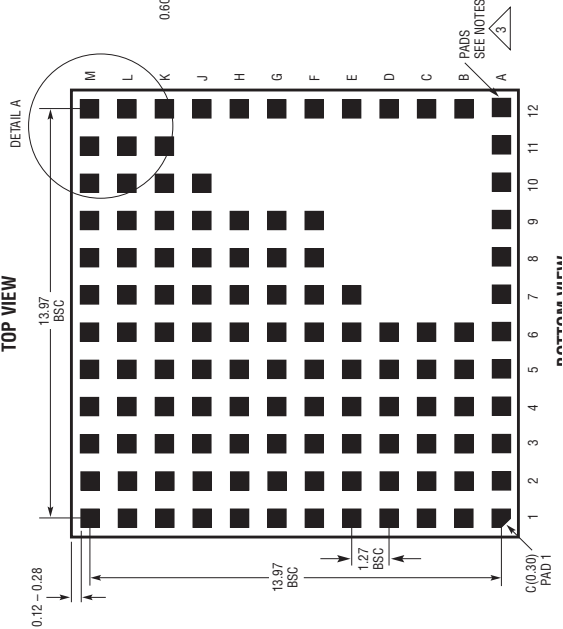

PADS
SEE NOTES
3

TYPICAL APPLICATION

3.3V at 5A, LTM4603-1 (No Remote Sense Amplifier)

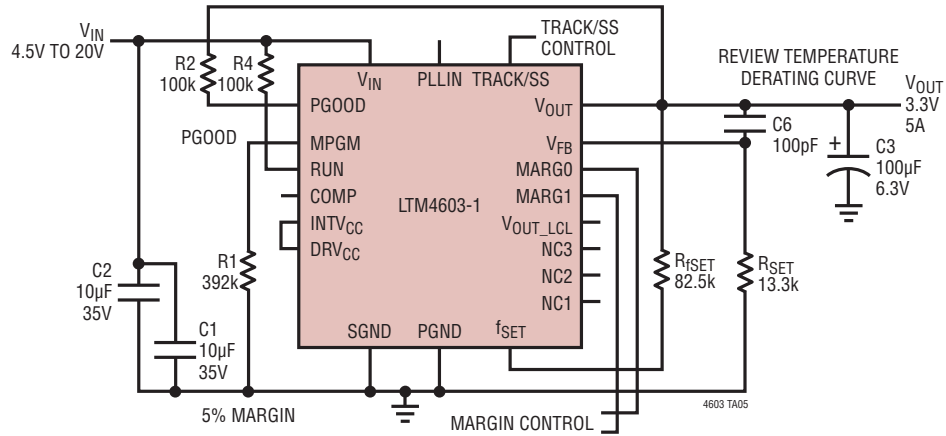

RELATED PARTS

| PART NUMBER | DESCRIPTION | COMMENTS |
|---------------|---|---|
| LTC2900 | Quad Supply Monitor with Adjustable Reset Timer | Monitors Four Supplies; Adjustable Reset Timer |
| LTC2923 | Power Supply Tracking Controller | Tracks Both Up and Down; Power Supply Sequencing |
| LT3825/LT3837 | Synchronous Isolated Flyback Controllers | No Optocoupler Required; 3.3V, 12A Output; Simple Design |
| LTM4600 | 10A DC/DC µModule | Basic 10A Power Supply |
| LTM4601 | 12A DC/DC µModule | with PLL, Output Tracking and Margining, LTM4603 Pin Compatible |
| LTM4602 | 6A DC/DC µModule | Basic 6A Power Supply |