

Vibration limit switch

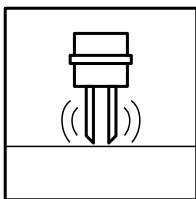

Vibracon LVL-M NAMUR



Ü



CE

Features

- Large selection of process connections: universal use
- Small dimensions of the vibrating fork and process connections $\frac{3}{4}$ " for areas with difficult access
- NAMUR signal output
- No calibration: quick and low-cost start-up
- No mechanically moving parts: maintenance-free, no wear, long operating life
- Monitoring of the vibration fork for damage: guaranteed function

Dimensions

Vibracon LVL-M with plastic housing and process connection G□□

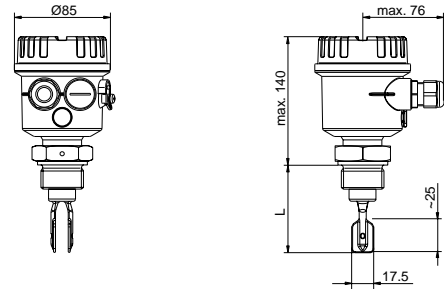

Vibracon LVL-M with aluminium housing and process connection with flange

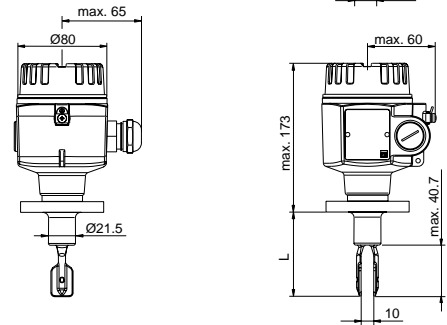

Length L see process connections

Function

The Vibracon is a level limit switch for use in all liquids.

- with a temperature between -40 °C (233 K) and $+150\text{ °C}$ (423 K)
- with a pressure up to 64 bar
- with a viscosity up to $10,000\text{ mm}^2/\text{s}$
- with a density up to 0.5 g/cm^3 .

The function is not affected by flow, turbulence, bubbles, foam, vibration, bulk solids content or build-up, the Vibracon is thus the ideal replacement for float switches.

Compact version, ideal for mounting in pipes (LVL-M1).

With extension tube up to 3 m (LVL-M2).

High corrosion-resistant Alloy C4 (2.4610) is available for the vibration fork and process connection for applications in very aggressive liquids.

Instruments with protection EEx ia and EEx d are available for use in explosion hazardous areas.

Electrical connection

Example: connection FEL 56 (N1) 2-wire connection

Other connection types see section electrical connections.

2-wire connection for separate switching unit

For connection to transformer isolated barriers to NAMUR (IEC 60947-5-6), e. g. transformer isolated barrier KFD2-SR2-Ex1.W or Remote Process Interface KSD-BI-Ex2 from Pepperl+Fuchs.
Output signal jump from low to high current on limit level.

(L-H edge)

Connection for multiplexer:
Adjust clock time to min. 2 s.

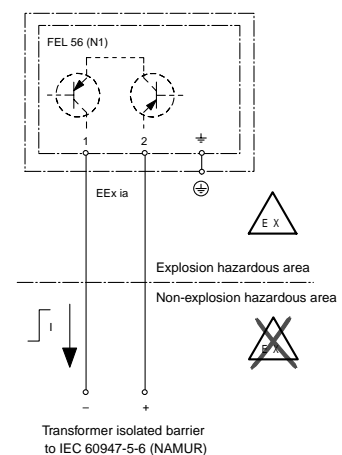

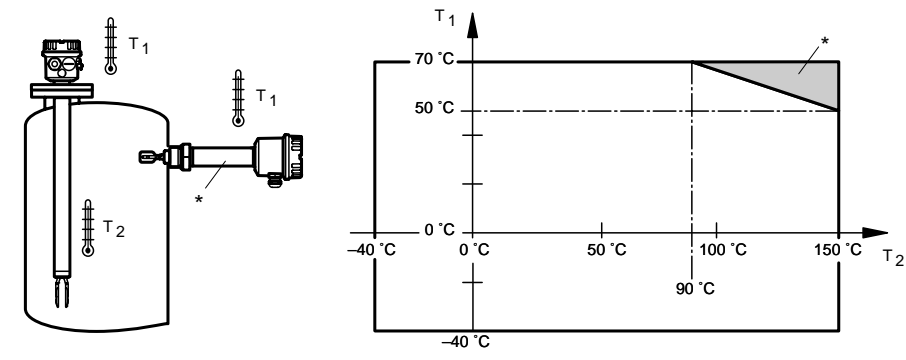
	Vibracon LVL-M NAMUR
Application	
Function principle	Limit detection Maximum or minimum detection in tanks or pipelines containing all types of liquids including use in explosion hazardous areas and in foodstuff and pharmaceutical industries.
Function and system design	
Measuring principle	The forks of the sensor vibrate at their intrinsic frequency. This frequency is reduced when covered with liquid. The change in frequency then activates the limit switch.
Input characteristics	
Measured variable	Limit level (limit value)
Measurement range	LVL-M1: specified by mounting point. LVL-M2: specified by length of the sensor with extension tube (max. 3000 mm/115 inch).
Medium density	Adjustment on the electronic insert > 0.5 g/cm ³ or > 0.7 g/cm ³
Output characteristics	
Fail-safe mode	Switchable minimum/maximum closed circuit safety on the electronic insert <ul style="list-style-type: none"> • Max. = Maximum fail-safe mode The relay is de-energised when the probe is covered or the power supply fails. Application e. g. for overspill protection • Min. = Minimum fail-safe mode The relay is de-energised when the probe is free or the power supply fails. Application e. g. for dry-run protection
Switching time	approx. 0.5 s when covering the vibration fork approx. 1.0 s when uncovering the vibration fork
Power up response	When switching on the power supply the output assumes the alarm signal. After max. 2 s it assumes the correct switching mode.
Auxiliary energy	
Supply voltage	Transformer isolated barrier to EN 50227 (NAMUR)
Cable connection	Electronic inserts: cross section max. 2.5 mm ² , lace in end splice in accordance with DIN 46228 Ground lead in housing: cross section max. 2.5 mm ² External equipotential bonding: cross section max. 4 mm ²
Operating conditions	
Mounting conditions	
Mounting position	LVL-M1: any position LVL-M2: with short pipe (up to 500 mm) any position, with long pipe vertical
Ambient conditions	
Ambient temperature	-40 ... +70 °C (233 ... 343 K) Permissible ambient temperature T 1 at the housing depends on the product temperature T 2 in the vessel:
	 <p>The diagram shows a cross-section of a tank with a sensor probe inserted. The sensor has a temperature separator or pressure-tight bushing marked with an asterisk (*). The ambient temperature T₁ is measured at the sensor housing, and the product temperature T₂ is measured inside the tank. The graph plots T₁ (y-axis, -40 °C to 70 °C) against T₂ (x-axis, -40 °C to 150 °C). A horizontal dashed line is drawn at T₁ = 50 °C. A vertical dashed line is drawn at T₂ = 90 °C. A shaded triangular region in the upper right corner of the graph, bounded by the top edge (T₁ = 70 °C), the right edge (T₂ = 150 °C), and a diagonal line from (90 °C, 70 °C) to (150 °C, 50 °C), is marked with an asterisk (*).</p>
	* additional temperature range for sensors with a temperature separator or pressure-tight bushing
Ambient temperature limit	-50 ... +70 °C (223 ... 343 K), function with reduced data values
Storage temperature	-50 ... +80 °C (223 ... 353 K)
Climatic class	Climatic protection to IEC 68, part 2-38, fig. 2a
Protection class	DIN EN 60529, IP66/67
Vibration resistance	to IEC 68, part 2-6 (10 ... 55 Hz, 0.15 mm, 100 cycles)
Electromagnetic compatibility	Emitted interference to EN 61326, CLASS B equipment Interference immunity to EN 61326, annex A (industrial sector) and NAMUR EMC recommendation (NE 21)
Process conditions	
Medium temperature	-40 ... +150 °C (232 ... 423 K), exceptions see process connections
Medium pressure	-1 ... +64 bar, over the entire temperature range, for exceptions see process connections
Process pressure limits	Bursting pressure of membrane 200 bar
Thermal shock	max. 120 °C/s (max. 120 K/s)
State of aggregation	liquid
Density	min. 0.5 g/cm ³

Date of issue 25.07.2002

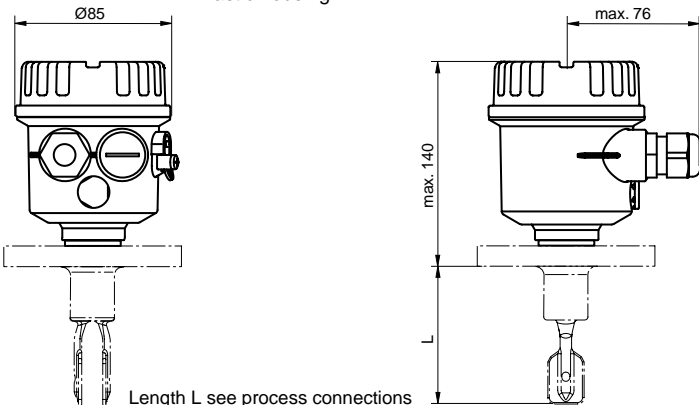
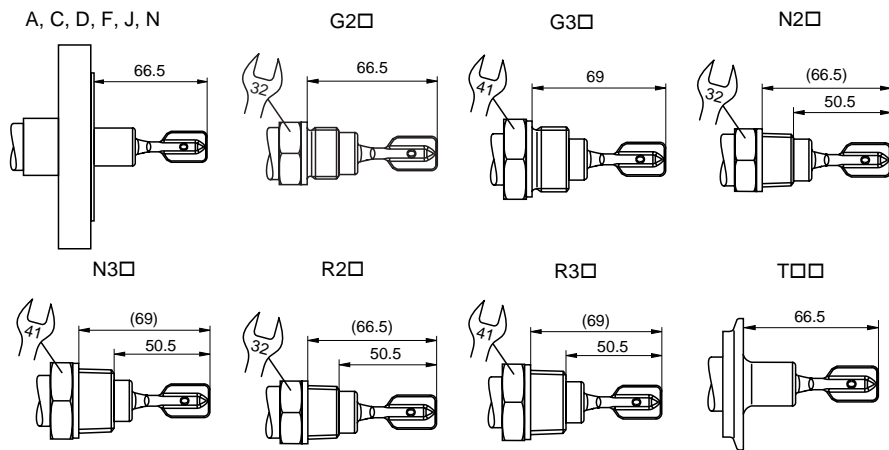
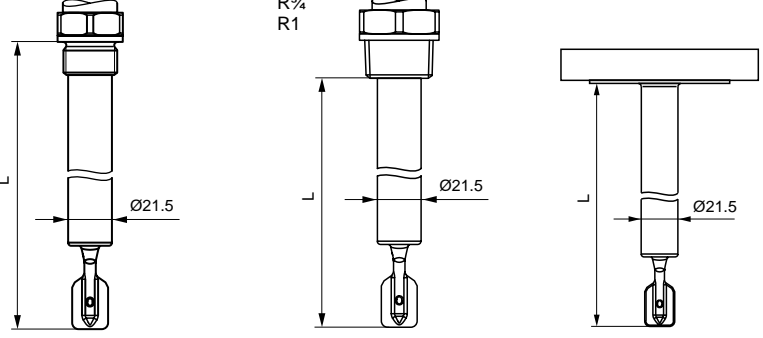
<p>Viscosity Bulk solids content</p>	<p>Vibracon LVL-M NAMUR max. 10000 mm²/s (max. 10000 cSt) max. Ø5 mm (max. Ø0.2 inch)</p>
<p>Mechanical construction Design</p>	<p>LVL-M1: compact design LVL-M2: version with extension tube</p>
<p>Dimensions</p>	<p>Housing: diameter max. 85 mm (3.3 inch), height max. 173 mm (6.8 inch), example</p> <p style="text-align: center;">Plastic housing P□</p>  <p style="text-align: center;">Length L see process connections</p> <p>Temperature separator, pressure-tight bushing: additional length L 140 mm (5.5 inch)</p> <p>Process connection: length L 66.5 ... 69 mm (2.6 ... 2.7 inch)</p> 
	<p>Extension: any length L from 148 ... 3000 mm (6 ... 115 inch), depending on the process connection</p> <p>Thread: G$\frac{3}{4}$A G1A</p> <p>Thread: $\frac{3}{4}$ NPT 1 NPT R$\frac{3}{4}$ R1</p> <p>Flange and flange-like process connections</p>  <p style="text-align: center;">from sealing surface of thread adapter from lower edge of thread</p> <p>Extension: length type II, for vertical installation from above same switching point as for Vibracon LVL1, LVL2</p>

Date of issue 25.07.2002

Vibracon LVL-M NAMUR

Vibration fork: width 17.5 mm (0.7 inch), fork width 10 mm (0.4 inch), max. length 40.7 mm (1.6 inch)

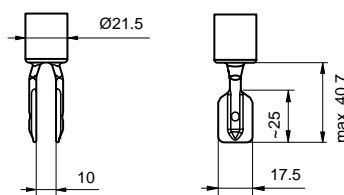

Weight

600 g, basic weight: compact design, electronic insert, steel housing, process connection G $\frac{3}{4}$ A

Switch point

Switch points on the sensor depend on the mounting location, with reference to water, density 1 g/cm³, 23 °C (296 K), p_e 0 bar.

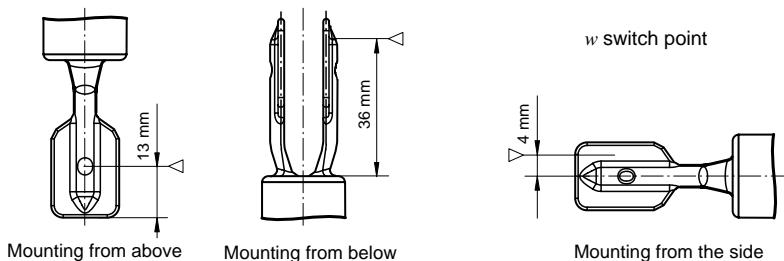

Note:

The switch points of the Vibracon LVL-M1, LVL-M2 are at other positions to those of the previous version LVL1, LVL2.

Indication and operation

Display elements

- Electronic insert FEL 56 (N1):
- green standby LED flashes
 - red LED for switch state indication is flashing in case of corrosion failure on the sensor or in case of electronic error
- Electronic insert FEL 58 (N2):
- green standby LED is quickly flashing
 - green standby LED is slowly flashing in case of corrosion failure on the sensor or in case of electronic error
 - yellow LED for switch state indication
 - Test button interrupts lead

Operating elements

2 switches for safety and density switching

Certificates and approvals

Ex approval

see type code

Type of protection

see type code

Overspill protection

Z-65.11-306 (overspill protection WHG)

General information

Conformity to standards

all products: EN 61010-1, EN 61326
selected products:

KEMA 01 ATEX 2117	KEMA 01 ATEX 1089	KEMA 01 ATEX 1147 X
EN 61326	EN 61326	EN 61326-1
EN 61010-1	EN 61010-1	EN 50081-1
EN 50014	EN 50014	EN 50082-1
EN 50020	EN 50020	EN 61010-1
EN 50284	EN 50284	EN 50014
		EN 50020
		EN 50284

Supplementary information

www.pepperl-fuchs.com

Accessories

Designation

- LVL-Z100, welding sleeve G $\frac{3}{4}$
- LVL-Z101, welding sleeve G1, flush mounted
- LVL-Z120, sliding sleeve for unpressurised operation G1A
- LVL-Z121, sliding sleeve for unpressurised operation G1 $\frac{1}{2}$ A
- LVL-Z124, high pressure sliding sleeve G1A
- LVL-Z126, high pressure sliding sleeve G1 $\frac{1}{2}$ A

Electrical connection

• Connection FEL 56 (N1)

2-wire connection for separate switching unit

For connecting to isolated switch amplifiers acc. to NAMUR (IEC 60947-5-6), e. g. isolated switch amplifier KFD2-SR2-Ex1.W or remote process interface KSD-BI-Ex2 from Pepperl+Fuchs. Output signal jump from low to high current on limit.

(L-H edge)

Connecting to multiplexer:
Adjust clock time to min. 2 s.

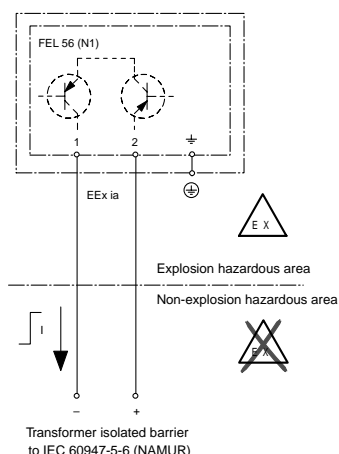

• Connection FEL 58 (N2)

2-wire connection for separate switching unit

For connecting to isolated switch amplifiers acc. to NAMUR (IEC 60947-5-6), e. g. isolated switch amplifier KFD2-SR2-Ex1.W or remote process interface KSD-BI-Ex2 from Pepperl+Fuchs. Output signal jump from high to low current on limit.

(H-L edge)

Additional function: Test key on the electronic insert. Pressing the key breaks the connection to the isolated switch amplifier.

Note: The test function can be used for EEx d applications provided that no explosive atmosphere is present near to the housing.

Connecting to multiplexer:
Adjust clock time to min. 2 s.

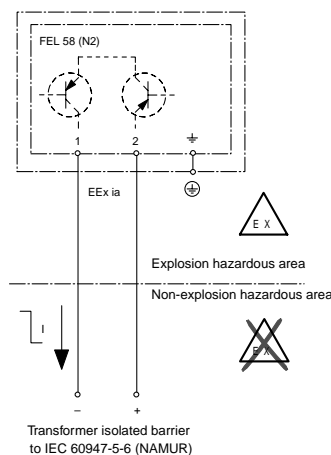

Type code/model number



- Specification of length without unit design M2**
- Certificates and approvals**
- NA** Version for non-explosion hazardous area
 - WH** Overspill protection WHG
 - EB** II 1/2G, EEx ia IIC T6, overspill protection WHG
 - E2** II 1/2G, EEx ia IIC T6
 - E3** II 1/2G, EEx xd IIC T6
 - EC** II 1/2G, EEx xd IIC T6, overspill protection WHG
 - FI** FM IS Cl. I, II, III, Div. 1, Group A - G
 - FX** FM XP Cl. I, II, III, Div. 1, Group A - G
 - CI** CSA IS Cl. I, II, III, Div. 1, Group A - G
 - CG** CSA general purpose
 - CX** CSA XP Cl. I, II, III, Div. 1, Group A - G
- Additional fittings**
- NA** without optional equipment
 - Z3** 3.1.B material, wetted parts 1.4435/316L; inspection certificate to EN 10204, according to specification 52005759
- Electrical output**
- N1** FEL 56, NAMUR, L-H edge
 - N2** FEL 58, NAMUR with test key, H-L edge
- Housing, cable entry**
- A1** Aluminium housing, IP66, cable gland M20
 - A2** Aluminium housing, NEMA 4X, ¾ NPT
 - A4** Aluminium housing, IP66, connector M12 x 1
 - E1** Stainless steel housing (1.4301/304L), IP66, cable gland M20
 - E2** Stainless steel housing (1.4301/304L), NEMA 4X, ½ NPT
 - E4** Stainless steel housing (1.4301/304L), IP66, connector M12 x 1
 - P1** Plastic housing, IP66, cable gland M20
 - P2** Plastic housing, NEMA 4X, ½ NPT
 - P4** Plastic housing, IP66, connector M12 x 1
- Length, temperature separator, pressure-tight bushing**
- Design M1 **AA** Compact design, Ra < 3.2 µm/80 grit
 - Design M1 **IA** 66 mm/2.6" with temperature separator
 - Design M1 **QA** 66 mm/2.6" with pressure-tight bushing
 - Design M2 **BB** mm L 1.4435/316L, Ra < 3.2 µm
 - Design M2 **BE** mm L Alloy C4/2.4610, Ra < 3.2 µm
 - Design M2 **CB** inch L 1.4435/316L, Ra < 3.2 µm
 - Design M2 **CE** inch L Alloy C4/2.4610, Ra < 3.2 µm
 - Design M2 **DB** Length type II, 1.4435/316L, Ra < 3.2 µm, switch point = Vibracon compact
 - Design M2 **DE** Length type II, Alloy C4/2.4610, Ra < 3.2 µm, switch point = Vibracon compact
 - Design M2 **JB** mm L 1.4435/316L, with temperature separator
 - Design M2 **JE** mm L Alloy C4/2.4610, with temperature separator
 - Design M2 **KB** inch L 1.4435/316L, with temperature separator
 - Design M2 **KE** inch L Alloy C4/2.4610, with temperature separator
 - Design M2 **LB** Length type II, 1.4435/316L, with temperature separator
 - Design M2 **LE** Length type II, Alloy C4/2.4610, with temperature separator, switch point = Vibracon compact
 - Design M2 **RB** mm L 1.4435/316L, with pressure-tight bushing
 - Design M2 **RE** mm L Alloy C4/2.4610, with pressure-tight bushing
 - Design M2 **SB** inch L 1.4435/316L, with pressure-tight bushing
 - Design M2 **SE** inch L Alloy C4/2.4610, with pressure-tight bushing
 - Design M2 **TB** Length type II, 1.4435/316L, with pressure-tight bushing, switch point = Vibracon compact
 - Design M2 **TE** Length type II, Alloy C4/2.4610, with pressure-tight bushing, switch point = Vibracon compact
- Process connection and material**
- A31** ANSI 1" 150 lbs RF, 1.4435/316L
 - A41** ANSI 1¼" 150 lbs RF, 1.4435/316L
 - A51** ANSI 1½" 150 lbs RF, 1.4435/316L
 - A61** ANSI 2" 150 lbs RF, 1.4435/316L
 - A6C** ANSI 2" 150 lbs RF, with Alloy C4/2.4610 platinised
 - A81** ANSI 3" 150 lbs RF, 1.4435/316L
 - F55** DN32 PN40 form B, 1.4435/316L
 - F65** DN40 PN40 form B, 1.4435/316L
 - F75** DN50 PN40 form B, 1.4435/316L
 - F85** DN65 PN40 form B, 1.4435/316L
 - F95** DN80 PN40 form B, 1.4435/316L
 - FA5** DN100 PN40 form B, 1.4435/316L
 - D51** DN32 PN6 form C, 1.4435/316L, sealing strip
 - C51** DN32 PN6 form C, with Alloy C4/2.4610 platinised
 - D71** DN50 PN6 form C, 1.4435/316L, sealing strip
 - C71** DN50 PN6 form C, with Alloy C4/2.4610 platinised
 - D95** DN80 PN40 form C, 1.4435/316L, sealing strip
 - C95** DN80 PN40 form C, with Alloy C4/2.4610 platinised
 - DA3** DN100 PN16 form C, 1.4435/316L, sealing strip
 - CA3** DN100 PN16 form C, with Alloy C4/2.4610 platinised
 - N21** ¾ NPT, 1.4435/316L
 - N2C** ¾ NPT, Alloy C4/2.4610
 - N31** 1 NPT, 1.4435/316L
 - N3C** 1 NPT, Alloy C4/2.4610
 - G21** BSP¾ (G¾), 1.4435/316L
 - G2C** BSP¾ (G¾), Alloy C4/2.4610
 - G31** BSP1 (G1), 1.4435/316L
 - G3C** BSP1 (G1), Alloy C4/2.4610
 - G3E** BSP1 (G1), 1.4435/316L, mounting for welding sleeve
 - T51** 1½" Triclamp ISO 2852 1.4435/316L
 - T61** 2" Triclamp ISO 2852 1.4435/316L
 - XXX** Special version
- Design**
- M1** Compact design
 - M2** Extended design (148 mm/6 inch ... 3000 mm/115 inch)

Date of issue 25.07.2002