

## DB800ZL 8-OUTPUT PCIe GEN 3 BUFFER/ZERO DELAY BUFFER

### Features

- Eight 0.7 V low-power, push-pull, HCSL-compatible PCIe Gen 3 outputs
- Individual OE HW pins for each output clock
- 100 MHz /133 MHz PLL operation, supports PCIe and QPI
- SMBus address configurable to allow multiple buffers in a single control network 3.3 V supply voltage operation
- PLL or bypass mode
- Spread spectrum tolerable
- 1.05 to 3.3 V power supply voltage
- Intel® QPI, PCIe Gen 1/Gen 2/ Gen 3 compliant
- Industrial Temperature: -40 to 85 °C
- 48-pin QFN
- For higher output devices or variations of this device, contact Silicon Labs



Patents pending

### Applications

- Server
- Storage
- Datacenter
- Enterprise Switches and Routers

### Description

The Si53108 is a low-power, 8-output, differential clock buffer that meets all of the performance requirements of the Intel DB800ZL specification. The device is optimized for distributing reference clocks for Intel® QuickPath Interconnect (Intel QPI), PCIe Gen 1/Gen 2/Gen 3, SAS, SATA, and Intel Scalable Memory Interconnect (Intel SMI) applications. The VCO of the device is optimized to support 100 MHz and 133 MHz operation. Each differential output has a dedicated hardware output enable pin for maximum flexibility and power savings.

# Si53108

## Functional Block Diagram

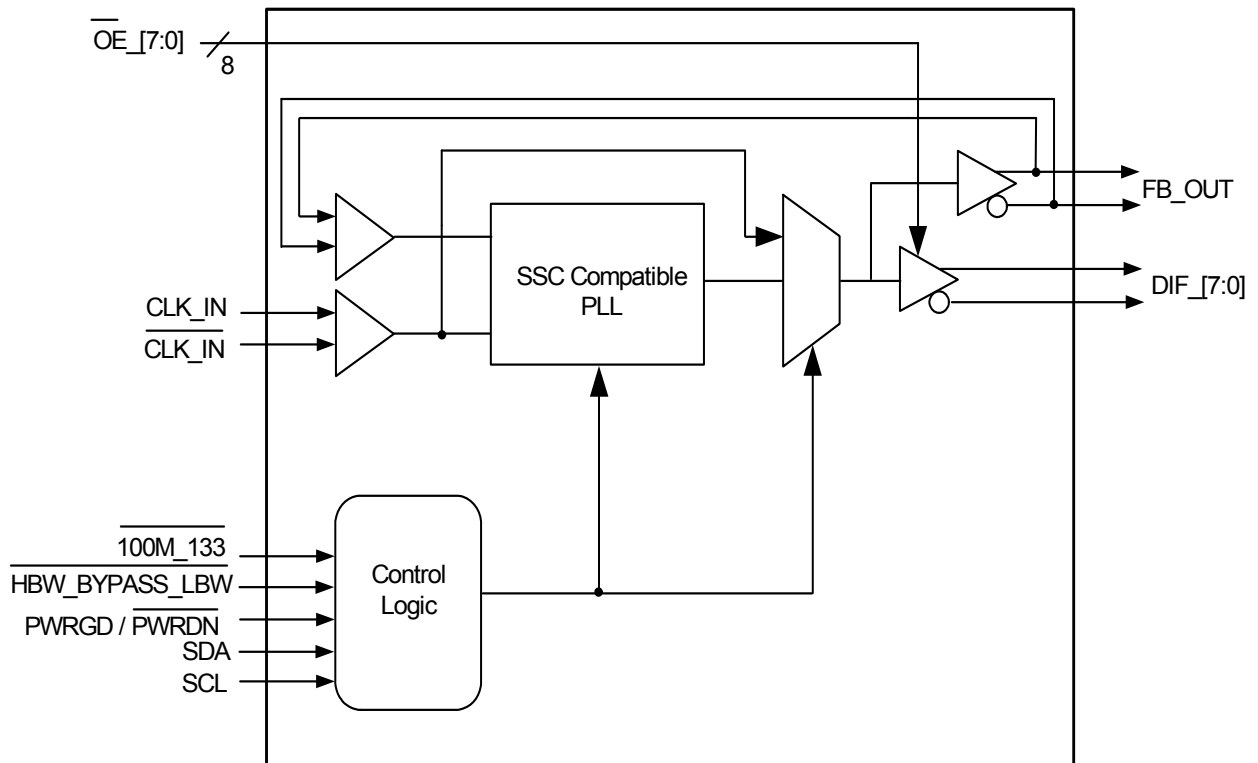

---

**TABLE OF CONTENTS**

---

<b><u>Section</u></b>	<b><u>Page</u></b>
<b>1. Electrical Specifications</b> .....	<b>4</b>
<b>2. Functional Description</b> .....	<b>13</b>
2.1. CLK_IN, CLK_IN .....	13
2.2. OE and Output Enables (Control Registers) .....	13
2.3. 100M_133M—Frequency Selection .....	13
2.4. PWRGD/PWRDN .....	14
2.5. HBW_BYPASS_LBW .....	16
2.6. Miscellaneous Requirements .....	16
<b>3. Test and Measurement Setup</b> .....	<b>17</b>
3.1. Input Edge .....	17
3.2. Termination of Differential Outputs .....	18
<b>4. Control Registers</b> .....	<b>19</b>
4.1. Byte Read/Write .....	19
4.2. Block Read/Write .....	20
4.3. Control Registers .....	21
<b>5. Power Filtering Example</b> .....	<b>26</b>
5.1. Ferrite Bead Power Filtering .....	26
<b>6. Pin Descriptions: 48-Pin QFN</b> .....	<b>27</b>
<b>7. Ordering Guide</b> .....	<b>30</b>
<b>8. Package Outline</b> .....	<b>31</b>
<b>9. Land Pattern</b> .....	<b>33</b>
<b>Contact Information</b> .....	<b>35</b>

## 1. Electrical Specifications

**Table 1. Absolute Maximum Ratings**

Parameter	Symbol	Min	Max	Unit
3.3 V Core Supply Voltage <sup>1</sup>	$V_{DD}/V_{DD\_A}$	—	4.6	V
3.3 V I/O Supply Voltage <sup>1</sup>	$V_{DD\_IO}$	—	4.6	V
3.3 V Input High Voltage <sup>1,2</sup>	$V_{IH}$	—	4.6	V
3.3 V Input Low Voltage <sup>1</sup>	$V_{IL}$	-0.5	—	V
Storage Temperature <sup>1</sup>	$t_s$	-65	150	°C
Input ESD protection <sup>3</sup>	ESD	2000	—	V

**Notes:**

1. Consult manufacturer regarding extended operation in excess of normal DC operating parameters.
2. Maximum  $V_{IH}$  is not to exceed maximum  $V_{DD}$ .
3. Human body model.

**Table 2. DC Operating Characteristics**

$V_{DD\_A} = 3.3\text{ V} \pm 5\%$ ,  $V_{DD} = 3.3\text{ V} \pm 5\%$

Parameter	Symbol	Test Condition	Min	Max	Unit
3.3 V Core Supply Voltage	$V_{DD}/V_{DD\_A}$	3.3 V $\pm$ 5%	3.135	3.465	V
3.3 V Input High Voltage	$V_{IH}$	VDD	2.0	VDD+0.3	V
3.3 V Input Low Voltage	$V_{IL}$		VSS-0.3	0.8	V
Input Leakage Current <sup>1</sup>	$I_{IL}$	0 < $V_{IN}$ < VDD	-5	+5	$\mu$ A
3.3 V Input High Voltage <sup>2</sup>	$V_{IH\_FS}$	VDD	0.7	VDD+0.3	V
3.3 V Input Low Voltage <sup>2</sup>	$V_{IL\_FS}$		VSS-0.3	0.35	V
3.3 V Input Low Voltage	$V_{IL\_Tri}$		0	0.8	V
3.3 V Input Med Voltage	$V_{IM\_Tri}$		1.2	1.8	V
3.3 V Input High Voltage	$V_{IH\_Tri}$		2.2	VDD	V
3.3 V Output High Voltage <sup>3</sup>	$V_{OH}$	$I_{OH} = -1\text{ mA}$	2.4	—	V
3.3 V Output Low Voltage <sup>3</sup>	$V_{OL}$	$I_{OL} = 1\text{ mA}$	—	0.4	V
Input Capacitance <sup>4</sup>	$C_{IN}$		2.5	4.5	pF
DIFF_IN Capacitance	$C_{DIF\_IN}$		1.5	2.7	pF
Output pin Capacitance	$C_{OUT}$			6	pF
Output Capacitance <sup>4</sup>	$C_{OUT}$		2.5	4.5	pF
Pin Inductance	$L_{PIN}$		—	7	nH
Ambient Temperature	$T_A$	No Airflow	-40	85	°C

**Notes:**

1. Input Leakage Current does not include inputs with pull-up or pull-down resistors. Inputs with resistors should state current requirements.
2. Internal voltage reference is to be used to guarantee  $V_{IH\_FS}$  and  $V_{IL\_FS}$  thresholds levels over full operating range.
3. Signal edge is required to be monotonic when transitioning through this region.
4. Ccomp capacitance based on pad metallization and silicon device capacitance. Not including pin capacitance.

**Table 3. Clock Input Parameters** $T_A = -40$  to  $85$  °C; supply voltage  $V_{DD} = 3.3$  V  $\pm 5\%$ 

Parameter	Symbol	Test Condition	Min	Typ	Max	Unit
Input Frequency	$F_{IN}$	Bypass Mode	33	—	150	MHz
		PLL Mode, 100 MHz	90	100	110	MHz
		PLL Mode, 133.33 MHz	120	133.33	147	MHz
Input High Voltage- CLK_IN	$V_{IHDIF}$	Differential inputs single-ended measurement	600	800	1150	mV
Input Low Voltage- CLK_IN	$V_{ILDIF}$	Differential inputs single-ended measurement	$V_{SS} - 300$	0	300	mV
Input Common Mode Voltage - CLK_IN	$V_{COM}$	Common Mode Voltage Input	300	—	1000	mV
Input Amplitude- CLK_IN	$V_{Swing}$	Peak to Peak	300	—	1450	
Input Slew Rate- CLK_IN	$IDD_{VDDAPD}$	Measured differentially	0.4	—	8	V/ns
Input Leakage Current	$I_{IN}$	$V_{IN} = V_{DD}$ , $V_{IN} = GND$	-5	—	5	$\mu A$
Input Duty Cycle	$d_{tin}$	Measured from differential waveform	45	—	55	%
Input Jitter, Cycle-Cycle	$J_{DIFIN}$	Differential measurement	0	—	125	ps
Input SS Modulation Frequency	$f_{MODIN}$	Triangle Wave Modulation	30	—	33	kHz

**Table 4. Current Consumption** $T_A = -40$  to  $85$  °C; supply voltage  $V_{DD} = 3.3$  V  $\pm 5\%$ 

Parameter	Symbol	Test Condition	Min	Typ	Max	Unit
Operating Current	$IDD_{VDD}$	133 MHz, VDD Rail	—	79	90	mA
	$IDD_{VDDA}$	133 MHz, VDDA + VDDR, PLL Mode	—	14	20	mA
Power Down Current	$IDD_{VDDPD}$	Power Down, VDD Rail	—	1	1.5	mA
	$IDD_{VDDAPD}$	Power Down, VDDA Rail	—	4	8	mA

**Table 5. Output Relational Timing Parameters**

$T_A = -40$  to  $85$  °C; supply voltage  $V_{DD} = 3.3$  V  $\pm 5\%$

Parameter	Test Condition	Min	TYP	Max	Unit	Notes
CLK_IN, DIF[x:0]	Input-to-Output Delay in PLL Mode Nominal Value	-100	20	100	ps	1,2,4,5
CLK_IN, DIF[x:0]	Input-to-Output Delay in Bypass Mode Nominal Value	2.5	3.3	4.5	ns	2,3,5
CLK_IN, DIF[x:0]	Input-to-Output Delay Variation in PLL mode (over voltage and temperature) Nominal Value	-100	39	100	ps	2,3,5
CLK_IN, DIF[x:0]	Input-to-Output Delay Variation in Bypass Mode (over voltage and temperature) Nominal Value	-250		250	ps	2,3,5
CLK_IN, DIF[7:0]	Output-to-Output Skew across all 12 out- puts (Common to Bypass and PLL mode)	0	25	50	ps	1,2,3,5

**Notes:**

1. Measured into fixed 2 pF load cap. Input-to-output skew is measured at the first output edge following the corresponding input.
2. Measured from differential cross-point to differential cross-point.
3. All Bypass Mode Input-to-Output specs refer to the timing between an input edge and the specific output edge created by it.
4. This parameter is deterministic for a given device.
5. Measured with scope averaging on to find mean value

**Table 6. PLL Bandwidth and Peaking**

$T_A = -40$  to  $85$  °C; supply voltage  $V_{DD} = 3.3$  V  $\pm 5\%$

Parameter	Test Condition	Min	TYP	Max	Unit	Notes
PLL Jitter Peaking	$\overline{HBW\_BYPASS\_LBW} = 0$	—	0.4	2.0	dB	2
PLL Jitter Peaking	$\overline{HBW\_BYPASS\_LBW} = 1$	—	0.1	2.0	dB	2
PLL Bandwidth	$\overline{HBW\_BYPASS\_LBW} = 1$	2	0.7	4	MHz	1
PLL Bandwidth	$\overline{HBW\_BYPASS\_LBW} = 0$	0.7	2	1.4	MHz	1

**Notes:**

1. Measured at 3 db down or half power point.
2. Measured as maximum pass band gain. At frequencies with the loop BW, highest point of magnification is call PLL jitter peaking.

Table 7. Phase Jitter

Parameter	Test Condition	Min	Typ	Max	Unit
Phase Jitter PLL Mode	PCIe Gen 1 <sup>1,2,7</sup>	—	29	86	ps
	PCIe Gen 2 Low Band F < 1.5 MHz <sup>1,2,3,4</sup>	—	2.0	3.0	ps (RMS)
	PCIe Gen 2 High Band 1.5 MHz < F < Nyquist <sup>1,2,3,4</sup>	—	1.9	3.1	ps (RMS)
	PCIe Gen 3 (PLL BW 2–4 MHz, CDR = 10 MHz) <sup>1,2,3,4</sup>	—	0.45	1.0	ps (RMS)
	Intel® QPI & Intel SMI (4.8 Gbps or 6.4 Gb/s, 100 or 133 MHz, 12 UI) <sup>1,5, 6</sup>	—	0.21	0.5	ps (RMS)
	Intel QPI & Intel SMI (8 Gb/s, 100 MHz, 12 UI) <sup>1,5</sup>	—	0.13	0.3	ps (RMS)
	Intel QPI & Intel SMI (9.6 Gb/s, 100 MHz, 12 UI) <sup>1,5</sup>	—	0.11	0.2	ps (RMS)
Additive Phase Jitter Bypass Mode	PCIe Gen 1 <sup>1,2,7</sup>	—	10	—	ps
	PCIe Gen 2 Low Band F < 1.5 MHz <sup>1,2,3,4</sup>	—	1.2	—	ps (RMS)
	PCIe Gen 2 High Band 1.5 MHz < F < Nyquist <sup>1,2,3,4</sup>	—	1.3	—	ps (RMS)
	PCIe Gen 3 (PLL BW 2–4 MHz, CDR = 10 MHz) <sup>1,2,3,4</sup>	—	0.25	—	ps (RMS)
	Intel QPI & Intel® SMI (4.8 Gbps or 6.4 Gb/s, 100 or 133 MHz, 12 UI) <sup>1,5,6</sup>	—	0.12	—	ps (RMS)
	Intel QPI & Intel® SMI (8 Gb/s, 100 MHz, 12 UI) <sup>1,5</sup>	—	0.1	—	ps (RMS)
	Intel QPI & Intel® SMI (9.6 Gb/s, 100 MHz, 12 UI) <sup>1,5</sup>	—	0.09	—	ps (RMS)

**Notes:**

1. Post processed evaluation through Intel supplied Matlab\* scripts. Defined for a BER of 1E-12. Measured values at a smaller sample size have to be extrapolated to this BER target.
2.  $\zeta = 0.54$  implies a jitter peaking of 3 dB.
3. PCIe\* Gen 3 filter characteristics are subject to final ratification by PCISIG. Check the PCI-SIG for the latest specification.
4. Measured on 100 MHz PCIe output using the template file in the Intel-supplied Clock Jitter Tool V1.6.3.
5. Measured on 100 MHz output using the template file in the Intel-supplied Clock Jitter Tool V1.6.3.
6. Measured on 100 MHz, 133 MHz output using the template file in the Intel-supplied Clock Jitter Tool V1.6.3.
7. These jitter numbers are defined for a BER of 1E-12. Measured numbers at a smaller sample size have to be extrapolated to this BER target.

**Table 8. DIF 0.7 V AC Timing Characteristics (Non-Spread Spectrum Mode)**

Parameter	Symbol	CLK 100 MHz, 133 MHz			Unit	Notes
		Min	Typ	Max		
Clock Stabilization Time	$T_{STAB}$	—	—	1.8	ms	22
Long Term Accuracy	$L_{ACC}$	—	—	100	ppm	4,8,16
Absolute Host CLK Period (100 MHz)	$T_{ABS}$	9.94900	—	10.05100	ns	4,5,8
Absolute Host CLK Period (133 MHz)	$T_{ABS}$	7.44925	—	7.55075	ns	4,5,8
Edge_rate	Edge_rate	1.0	—	4.0	V/ns	2,4,8
Rise/Fall Matching	$T_{RISE\_MAT}/$ $T_{FALL\_MAT}$	—	—	20	%	4,7,19,21
Voltage High (typ 0.7 V)	$V_{HIGH}$	660	—	850	mV	3,8, 12
Voltage Low (typ 0.0 V)	$V_{LOW}$	-150	—	150	mV	4,7,11
Maximum Voltage	$V_{MAX}$	—	—	1150	mV	7
Absolute Crossing Point Voltages	$V_{CROSS(a$ $bs)}$	300	—	550	mV	1,3,4,7,14
Total Variation of $V_{cross}$ Over All Edges	Total $\Delta$ $V_{CROSS}$	—	—	140	mV	4,7,15
Cycle-to-Cycle Jitter	$T_{CCJITTER}$	—	—	50	ps	4,8,20
Duty Cycle	Duty Cycle	45	—	55	%	4,8
Maximum Voltage (Overshoot)	$V_{ovs}$	—	—	$V_{High} + 0.3$	V	4,7,12
Maximum Voltage (Undershoot)	$V_{uds}$	—	—	$V_{Low} - 0.3$	V	4,7,13

Table 8. DIF 0.7 V AC Timing Characteristics (Non-Spread Spectrum Mode) (Continued)

Parameter	Symbol	CLK 100 MHz, 133 MHz			Unit	Notes
		Min	Typ	Max		
Ringback Voltage	$V_{rb}$	0.2		N/A	V	4,7

**Notes:**

1. Measured at crossing point where the instantaneous voltage value of the rising edge of CLK equals the falling edge of CLK#
2. Measure taken from differential waveform on a component test board. The edge (slew) rate is measured from -150 mV to +150 mV on the differential waveform. Scope is set to average because the scope sample clock is making most of the dynamic wiggles along the clock edge Only valid for Rising clock and Falling Clock#. Signal must be monotonic through the  $V_{OL}$  to  $V_{OH}$  region for  $T_{RISE}$  and  $T_{FALL}$ .
3. This measurement refers to the total variation from the lowest crossing point to the highest, regardless of which edge is crossing
4. Test configuration is  $R_S = 33.2 \Omega$ ,  $R_P = 49.9$ , 2 pF for 100  $\Omega$  transmission line;  $R_S = 27 \Omega$ ,  $R_P = 42.2$ , 2 pF for 85  $\Omega$  transmission line
5. The average period over any 1  $\mu$ s period of time must be greater than the minimum and less than the maximum specified period
6.  $V_{CROSS}(rel)$  Min and Max are derived using the following,  $V_{CROSS}(rel)$  Min =  $0.250 + 0.5 (V_{HAVG} - 0.700)$ ,  $V_{CROSS}(rel)$  Max =  $0.550 - 0.5 (0.700 - V_{HAVG})$  (see Figure 3-4 for further clarification)
7. Measurement taken from Single Ended waveform
8. Measurement taken from differential waveform
9. Unless otherwise noted, all specifications in this table apply to all processor frequencies
10.  $V_{HIGH}$  is defined as the statistical average High value as obtained by using the Oscilloscope  $V_{HIGH}$  Math function
11.  $V_{LOW}$  is defined as the statistical average Low value as obtained by using the Oscilloscope  $V_{LOW}$  Math function
12. Overshoot is defined as the absolute value of the maximum voltage
13. Undershoot is defined as the absolute value of the minimum voltage
14. The crossing point must meet the absolute and relative crossing point specifications simultaneously
15.  $\Delta V_{CROSS}$  is defined as the total variation of all crossing voltages of Rising CLOCK and Falling CLOCK#. This is the maximum allowed variance in  $V_{CROSS}$  for any particular system
16. Using frequency counter with the measurement interval equal or greater than 0.15 s, target frequencies are 100,000,000 Hz, 133,333,333 Hz
17. Using frequency counter with the measurement interval equal or greater than 0.15 s, target frequencies are 99,750,00 Hz, 133,000,000 Hz
18. Measured with oscilloscope, averaging off, using min max statistics. Variation is the delta between min and max.
19. Measured with oscilloscope, averaging on, The difference between the rising edge rate (average) of clock verses the falling edge rate (average) of clock#
20. Measured with device in PLL mode, in BYPASS mode jitter is additive (up to 25ps of cycle-to-cycle jitter may add to the input jitter)
21. Rise/Fall matching is derived using the following,  $2 * (T_{RISE} - T_{FALL}) / (T_{RISE} + T_{FALL})$
22. This is the time from the valid CLK\_IN input clocks and the assertion of the PWRGD signal level at 1.8 V – 2.0 V to the time that stable clocks are output from the buffer chip (PLL locked)

**Table 9. DIF 0.7 V AC Timing Characteristics (–0.5% Spread Spectrum Mode)**

Parameter	Symbol	CLK 100 MHz, 133 MHz			Unit	Notes
		Min	Typ	Max		
Clock Stabilization Time	$T_{STAB}$	—		1.8	ms	22
Long Term Accuracy	$L_{ACC}$	—		100	ppm	4,8,16
Absolute Host CLK Period (100 MHz)	$T_{ABS}$	9.94900		10.10126	ns	4,5,8
Absolute Host CLK Period (133 MHz)	$T_{ABS}$	7.44925		7.58845	ns	4,5,8
Edge_rate	Edge_rate	1.0		4.0	V/ns	2,4,8
Rise/Fall Matching	$T_{RISE\_MAT}/$ $T_{FALL\_MAT}$	—		20	%	4,7,19,21
Voltage High (typ 0.70 V)	$V_{HIGH}$	660		850	mV	4,7,10
Voltage Low (typ 0.0 V)	$V_{LOW}$	–150		150	mV	4,7,11
Maximum Voltage	$V_{MAX}$	—		1150	mV	7
Absolute Crossing Point Voltages	$V_{CROSS(a$ $bs)}$	300		550	mV	1,3,4,7,14
Relative Crossing Point Voltages	$V_{CROSS(re$ $l)}$	Calc		Calc	mV	4,6,7,14
Total Variation of $V_{cross}$ Over All Edges	Total $\Delta$ $V_{CROSS}$	—		140	mV	4,7,15
Cycle-to-Cycle Jitter	$T_{CCJITTER}$			50	ps	4,8,20
Duty Cycle	Duty Cycle	45		55	%	4,8
Maximum Voltage (Overshoot)	$V_{ovs}$	—		$V_{High} + 0.3$	V	4,7,12
Maximum Voltage (Undershoot)	$V_{uds}$	—		$V_{Low} - 0.3$	V	4,7,13

Table 9. DIF 0.7 V AC Timing Characteristics (–0.5% Spread Spectrum Mode) (Continued)

Parameter	Symbol	CLK 100 MHz, 133 MHz			Unit	Notes
		Min	Typ	Max		
Ringback Voltage	$V_{rb}$	0.2		N/A	V	4,7

**Notes:**

1. Measured at crossing point where the instantaneous voltage value of the rising edge of CLK equals the falling edge of CLK#
2. Measure taken from differential waveform on a component test board. The edge (slew) rate is measured from -150 mV to +150 mV on the differential waveform. Scope is set to average because the scope sample clock is making most of the dynamic wiggles along the clock edge Only valid for Rising clock and Falling Clock#. Signal must be monotonic through the  $V_{OL}$  to  $V_{OH}$  region for  $T_{RISE}$  and  $T_{FALL}$ .
3. This measurement refers to the total variation from the lowest crossing point to the highest, regardless of which edge is crossing
4. Test configuration is  $R_S = 33.2 \Omega$ ,  $R_P = 49.9, 2 \text{ pF}$  for 100  $\Omega$  transmission line;  $R_S = 27 \Omega$ ,  $R_P = 42.2, 2 \text{ pF}$  for 85  $\Omega$  transmission line
5. The average period over any 1  $\mu\text{s}$  period of time must be greater than the minimum and less than the maximum specified period
6.  $V_{CROSS}(rel)$  Min and Max are derived using the following,  $V_{CROSS}(rel)$  Min =  $0.250 + 0.5 (V_{HAVG} - 0.700)$ ,  $V_{CROSS}(rel)$  Max =  $0.550 - 0.5 (0.700 - V_{HAVG})$  (see Figure 3-4 for further clarification)
7. Measurement taken from Single Ended waveform
8. Measurement taken from differential waveform
9. Unless otherwise noted, all specifications in this table apply to all processor frequencies
10.  $V_{HIGH}$  is defined as the statistical average High value as obtained by using the Oscilloscope  $V_{HIGH}$  Math function
11.  $V_{LOW}$  is defined as the statistical average Low value as obtained by using the Oscilloscope  $V_{LOW}$  Math function
12. Overshoot is defined as the absolute value of the maximum voltage
13. Undershoot is defined as the absolute value of the minimum voltage
14. The crossing point must meet the absolute and relative crossing point specifications simultaneously
15.  $\Delta V_{CROSS}$  is defined as the total variation of all crossing voltages of Rising CLOCK and Falling CLOCK#. This is the maximum allowed variance in  $V_{CROSS}$  for any particular system
16. Using frequency counter with the measurement interval equal or greater than 0.15 s, target frequencies are 100,000,000 Hz, 133,333,333 Hz
17. Using frequency counter with the measurement interval equal or greater than 0.15 s, target frequencies are 99,750,00 Hz, 133,000,000 Hz
18. Measured with oscilloscope, averaging off, using min max statistics. Variation is the delta between min and max.
19. Measured with oscilloscope, averaging on, The difference between the rising edge rate (average) of clock verses the falling edge rate (average) of clock#
20. Measured with device in PLL mode, in BYPASS mode jitter is additive (up to 25ps of cycle-to-cycle jitter may add to the input jitter)
21. Rise/Fall matching is derived using the following,  $2 * (T_{RISE} - T_{FALL}) / (T_{RISE} + T_{FALL})$
22. This is the time from the valid CLK\_IN input clocks and the assertion of the PWRGD signal level at 1.8 V – 2.0 V to the time that stable clocks are output from the buffer chip (PLL locked)

**Table 10. Clock Periods Differential Clock Outputs with SSC Disabled**

SSC ON Center Freq, MHz	Measurement Window							Unit
	1 Clock	1 $\mu$ s	0.1 s	0.1 s	0.1 s	1 $\mu$ s	1 Clock	
	-C-C Jitter AbsPer Min	-SSC Short Term AVG Min	-ppm Long Term AVG Min	0 ppm Period Nominal	+ppm Long Term AVG Max	+SSC Short Term AVG Max	+C-C Jitter AbsPer Max	
100.00	9.94900		9.99900	10.00000	10.00100		10.05100	ns
133.33	7.44925		7.49925	7.50000	7.50075		7.55075	ns

**Table 11. Clock Periods Differential Clock Outputs with SSC Enabled**

SSC ON Center Freq, MHz	Measurement Window							Unit
	1 Clock	1 $\mu$ s	0.1 s	0.1 s	0.1 s	1 $\mu$ s	1 Clock	
	-C-C Jitter AbsPer Min	-SSC Short Term AVG Min	-ppm Long Term AVG Min	0 ppm Period Nominal	+ppm Long Term AVG Max	+SSC Short Term AVG Max	+C-C Jitter AbsPer Max	
99.75	9.94900	9.99900	10.02406	10.02506	10.02607	10.05126	10.10126	ns
133.33	7.44925	7.49925	7.51805	7.51880	7.51955	7.53845	7.58845	ns

## 2. Functional Description

### 2.1. CLK\_IN, $\overline{\text{CLK\_IN}}$

The differential input clock can be sourced from a clock synthesizer, e.g. CK420BQ, CK509B, or CK410B+.

### 2.2. $\overline{\text{OE}}$ and Output Enables (Control Registers)

Each output can be individually enabled or disabled by SMBus control register bits. Additionally, each output of the DIF[7:0] has a dedicated  $\overline{\text{OE}}$  pin. The  $\overline{\text{OE}}$  pins are asynchronous, asserted-low signals. The Output Enable bits in the SMBus registers are active high and are set to enable by default. The disabled state for the Si53108 NMOS push-pull output is Low/Low. Please note that the logic level for assertion or deassertion is different in software than it is on hardware. This follows hardware default nomenclature for communication channels (e.g., output is enabled if the OE# pin is pulled low) and still maintains software programming logic (e.g., output is enabled if OE register is true). Table 12 is a truth table depicting enabling and disabling of outputs via hardware and software. Note that, for the output to be active, the control register bit must be a 1 *and* the  $\overline{\text{OE}}$  pin must be a 0.

**Note:** The assertion and deassertion of this signal is absolutely asynchronous.

**Table 12. Si53108 Output Management**

Inputs		$\overline{\text{OE}}$ Hardware Pins and Control Register Bits			Outputs	PLL State
PWRGD/ PWRDN	CLK_IN/ CLK_IN	SMBUS Enable Bit	$\overline{\text{OE}}$ Pin	DIF/DIF[11:0]	FB_OUT/ FB_OUT	
0	x	x	x	Low/Low	Low/Low	OFF
1	Running	0	x	Low/Low	Running	ON
		1	0	Running	Running	ON
		1	1	Low/Low	Running	ON

#### 2.2.1. $\overline{\text{OE}}$ Assertion (Transition from 1 to 0)

All differential outputs that were disabled are to resume normal operation in a glitch-free manner. The latency from the assertion to active outputs is 4 to 12 DIF clock periods.

#### 2.2.2. $\overline{\text{OE}}$ De-Assertion (Transition from 0 to 1)

The impact of deasserting  $\overline{\text{OE}}$  is that each corresponding output will transition from normal operation to disabled in a glitch-free manner. A minimum of four valid clocks will be provided after the deassertion of  $\overline{\text{OE}}$ . The maximum latency from the deassertion to disabled outputs is 12 DIF clock periods.

### 2.3. 100M\_133M—Frequency Selection

The Si53108 is optimized for lowest phase jitter performance at operating frequencies of 100 and 133 MHz. 100M\_133M is a hardware input pin, which programs the appropriate output frequency of the differential outputs. Note that the CLK\_IN frequency must be equal to the CLK\_OUT frequency; meaning Si53108 is operated in 1:1 mode only. Frequency selection can be enabled by the 100M\_133M hardware pin. An external pull-up or pull-down resistor is attached to this pin to select the input/output frequency. The functionality is summarized in Table 13.

**Table 13. Frequency Program Table**

100M_133M	Optimized Frequency (CLK_IN = CLK_OUT)
0	133.33 MHz
1	100.00 MHz

**Note:** All differential outputs transition from 100 to 133 MHz or from 133 to 100 MHz in a glitch free manner.

## 2.4. PWRGD/ $\overline{\text{PWRDN}}$

PWRGD is asserted high and deasserted low. Deassertion of PWRGD (pulling the signal low) is equivalent to indicating a power-down condition. PWRGD (assertion) is used by the Si53108 to sample initial configurations, such as frequency select condition and SA selections. After PWRGD has been asserted high for the first time, the pin becomes a  $\overline{\text{PWRDN}}$  (Power Down) pin that can be used to shut off all clocks cleanly and instruct the device to invoke power-saving mode.  $\overline{\text{PWRDN}}$  is a completely asynchronous active low input. When entering power-saving mode,  $\overline{\text{PWRDN}}$  should be asserted low prior to shutting off the input clock or power to ensure all clocks shut down in a glitch free manner. When  $\overline{\text{PWRDN}}$  is asserted low, all clocks will be disabled prior to turning off the VCO. When  $\overline{\text{PWRDN}}$  is deasserted high, all clocks will start and stop without any abnormal behavior and will meet all AC and DC parameters.

**Note:** The assertion and deassertion of  $\overline{\text{PWRDN}}$  is absolutely asynchronous.

**Warning:** Disabling of the CLK\_IN input clock prior to assertion of  $\overline{\text{PWRDN}}$  is an undefined mode and not recommended. Operation in this mode may result in glitches, excessive frequency shifting, etc.

**Table 14. PWRGD/ $\overline{\text{PWRDN}}$  Functionality**

$\overline{\text{PWRGD}}/\overline{\text{PWRDN}}$	DIF	$\overline{\text{DIF}}$
0	Low	Low
1	Normal	Normal

### 2.4.1. $\overline{\text{PWRDN}}$ Assertion

When  $\overline{\text{PWRDN}}$  is sampled low by two consecutive rising edges of  $\overline{\text{DIF}}$ , all differential outputs must be held LOW/LOW on the next  $\overline{\text{DIF}}$  high-to-low transition.

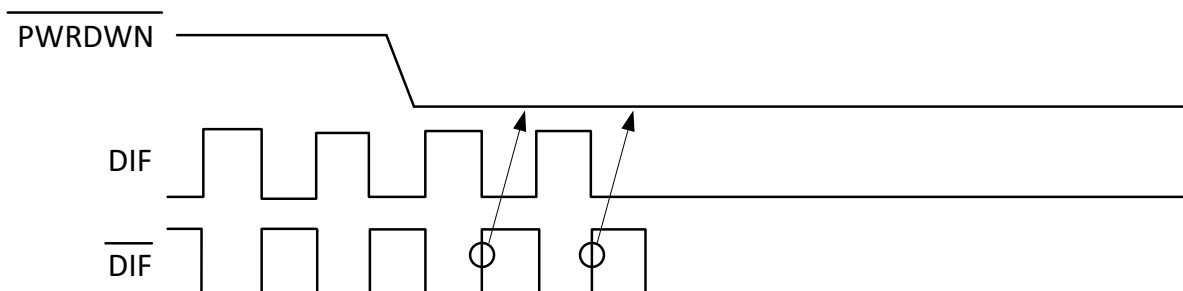

Figure 1.  $\overline{\text{PWRDN}}$  Assertion

### 2.4.2. PWRGD Assertion

The power-up latency is to be less than 1.8 ms. This is the time from a valid CLK\_IN input clock and the assertion of the PWRGD signal to the time that stable clocks are output from the device (PLL locked). All differential outputs stopped in a LOW/LOW condition resulting from power down must be driven high in less than 300  $\mu\text{s}$  of  $\overline{\text{PWRDN}}$  deassertion to a voltage greater than 200 mV.

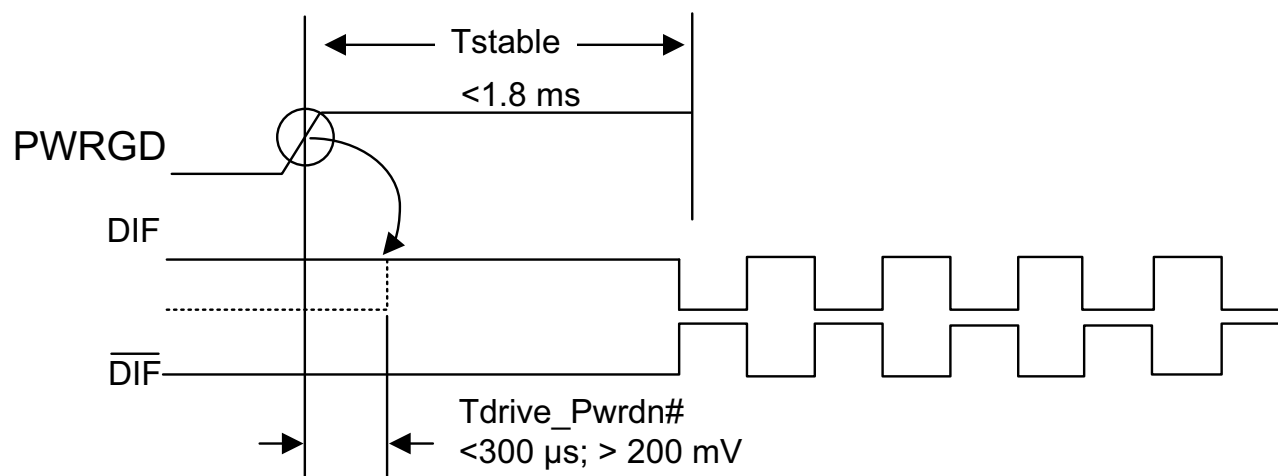

Figure 2. PWRGD Assertion (Pwrdown—Deassertion)

## 2.5. HBW\_BYPASS\_LBW

The HBW\_BYPASS\_LBW pin is a tri-level function input pin (refer to Table 15 for  $V_{IL\_Tri}$ ,  $V_{IM\_Tri}$ , and  $V_{IH\_Tri}$  signal levels). It is used to select between PLL high-bandwidth, PLL bypass mode, or PLL low-bandwidth mode. In PLL bypass mode, the input clock is passed directly to the output stage, which may result in up to 50 ps of additive cycle-to-cycle jitter (50 ps + input jitter) on the differential outputs. In the case of PLL mode, the input clock is passed through a PLL to reduce high-frequency jitter. The PLL HBW, BYPASS, and PLL LBW modes may be selected by asserting the HBW\_BYPASS\_LBW input pin to the appropriate level described in Table 15.

**Table 15. PLL Bandwidth and Readback Table**

<u>HBW_BYPASS_LBW</u> Pin	Mode	Byte 0, Bit 7	Byte 0, Bit 6
L	LBW	0	0
M	BYPASS	0	1
H	HBW	1	1

The Si53108 has the ability to override the latch value of the PLL operating mode from hardware strap pin 5 via the use of Byte 0 and bits 2 and 1. Byte 0 bit 3 must be set to 1 to allow the user to change Bits 2 and 1, affecting the PLL. Bits 7 and 6 will always read back the original latched value. A warm reset of the system will have to be accomplished if the user changes these bits.

## 2.6. Miscellaneous Requirements

**Data Transfer Rate:** 100 kbps (standard mode) is the base functionality required. Fast mode (400 kbps) functionality is optional.

**Logic Levels:** SMBus logic levels are based on a percentage of  $V_{DD}$  for the controller and other devices on the bus. Assume all devices are based on a 3.3 V supply.

**Clock Stretching:** The clock buffer must not hold/stretch the SCL or SDA lines low for more than 10 ms. Clock stretching is discouraged and should only be used as a last resort. Stretching the clock/data lines for longer than this time puts the device in an error/time-out mode and may not be supported in all platforms. It is assumed that all data transfers can be completed as specified without the use of clock/data stretching.

**General Call:** It is assumed that the clock buffer will not have to respond to the “general call.”

**Electrical Characteristics:** All electrical characteristics must meet the standard mode specifications found in Section 3 of the SMBus 2.0 specification.

**Pull-Up Resistors:** Any internal resistor pull-ups on the SDATA and SCLK inputs must be stated in the individual datasheet. The use of internal pull-ups on these pins of below 100 K is discouraged. Assume that the board designer will use a single external pull-up resistor for each line and that these values are in the 5–6 k $\Omega$  range. Assume one SMBus device per DIMM (serial presence detect), one SMBus controller, one clock buffer, one clock driver plus one/two more SMBus devices on the platform for capacitive loading purposes.

**Input Glitch Filters:** Only fast mode SMBus devices require input glitch filters to suppress bus noise. The clock buffer is specified as a standard mode device and is not required to support this feature. However, it is considered a good design practice to include the filters.

**PWRDN:** If a clock buffer is placed in PWRDN mode, the SDATA and SCLK inputs must be Tri-stated and the device must retain all programming information. IDD current due to the SMBus circuitry must be characterized and in the data sheet.

### 3. Test and Measurement Setup

#### 3.1. Input Edge

Input edge rate is based on single-ended measurement. This is the minimum input edge rate at which the Si53108 is guaranteed to meet all performance specifications.

**Table 16. Input Edge Rate**

Frequency	Min	Max	Unit
100 MHz	0.35	N/A	V/ns
133 MHz	0.35	N/A	V/ns

##### 3.1.1. Measurement Points for Differential

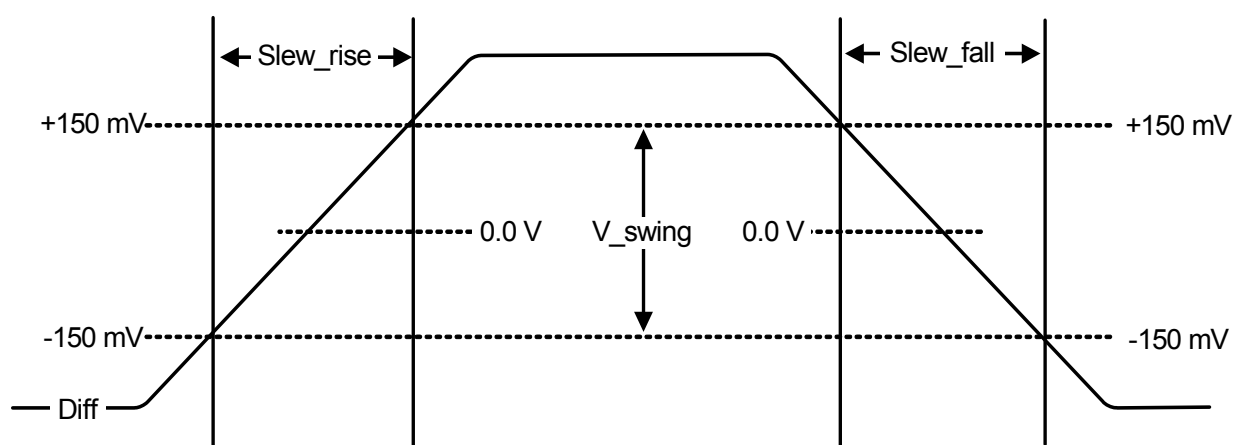

**Figure 3. Measurement Points for Rise Time and Fall Time**

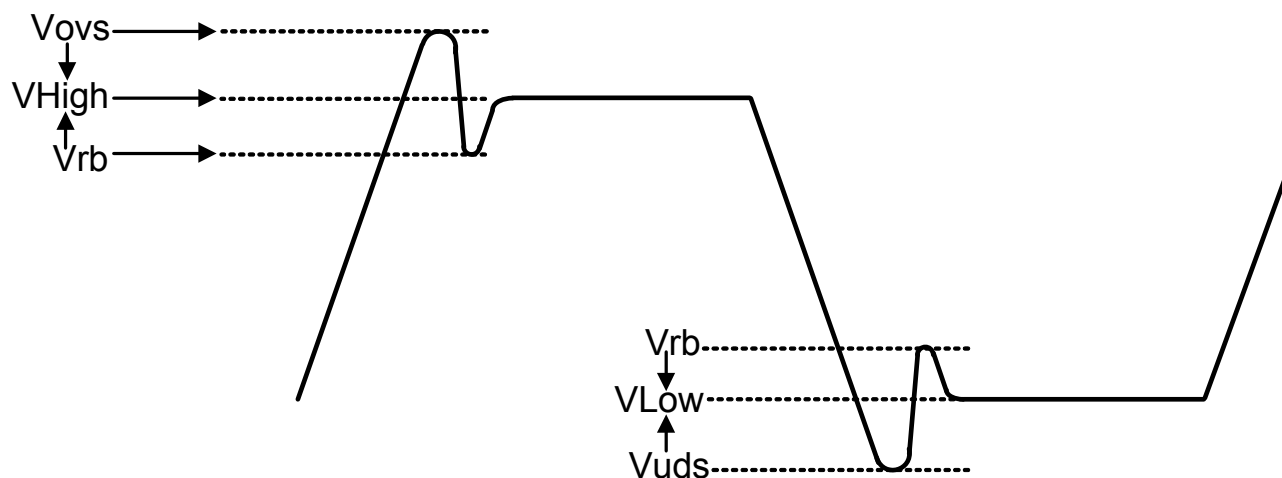

**Figure 4. Single-Ended Measurement Points for  $V_{OVS}$ ,  $V_{uds}$ ,  $V_{rb}$**

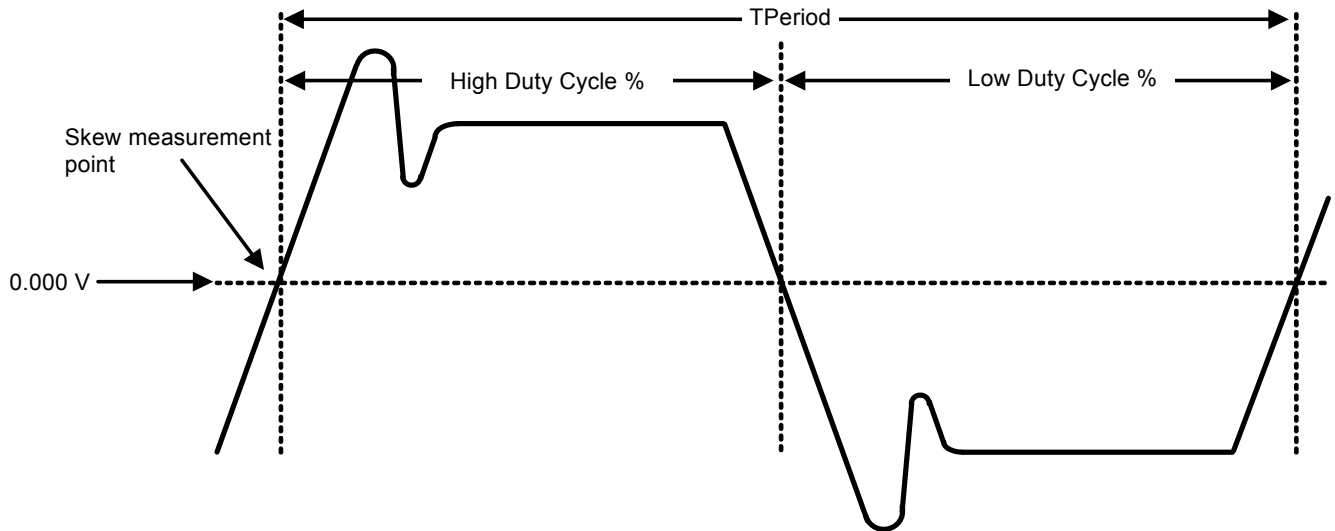

Figure 5. Differential (CLOCK-CLOCK) Measurement Points ( $T_{period}$ , Duty Cycle, Jitter)

3.2. Termination of Differential Outputs

All differential outputs are to be tested into a 100 Ω or 85 Ω differential impedance transmission line. Source terminated clocks have some inherent limitations as to the maximum trace length and frequencies that can be supported. For CPU outputs, a maximum trace length of 10” and a maximum of 200 MHz are assumed. For SRC clocks, a maximum trace length of 16” and maximum frequency of 100 MHz is assumed. For frequencies beyond 200 MHz, trace lengths must be restricted to avoid signal integrity problems.

Table 17. Differential Output Termination

Clock	Board Trace Impedance	Rs	Rp	Unit
DIFF Clocks—50 Ω configuration	100	33±5%	N/A	Ω
DIFF Clocks—43 Ω configuration	85	27±5%	N/A	Ω

3.2.1. Termination of Differential NMOS Push-Pull Type Outputs

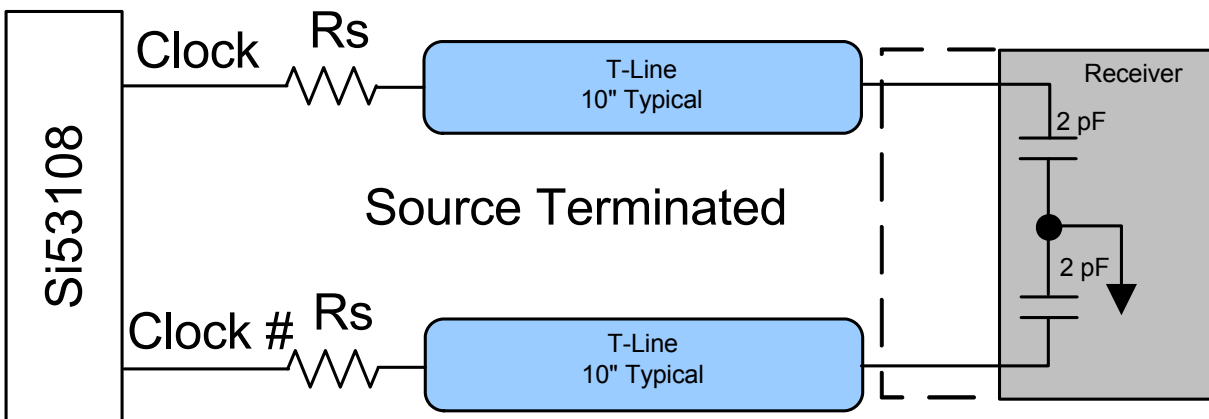

Figure 6. 0.7 V Configuration Test Load Board Termination for NMOS Push-Pull

## 4. Control Registers

### 4.1. Byte Read/Write

Reading or writing a register in an SMBus slave device in byte mode always involves specifying the register number.

#### 4.1.1. Byte Read

The standard byte read is as shown in Figure 7. It is an extension of the byte write. The write start condition is repeated; then, the slave device starts sending data, and the master acknowledges it until the last byte is sent. The master terminates the transfer with a NAK, then a stop condition. For byte operation, the 2 x 7th bit of the command byte must be set. For block operations, the 2 x 7th bit must be reset. If the bit is not set, the next byte must be the byte transfer count.

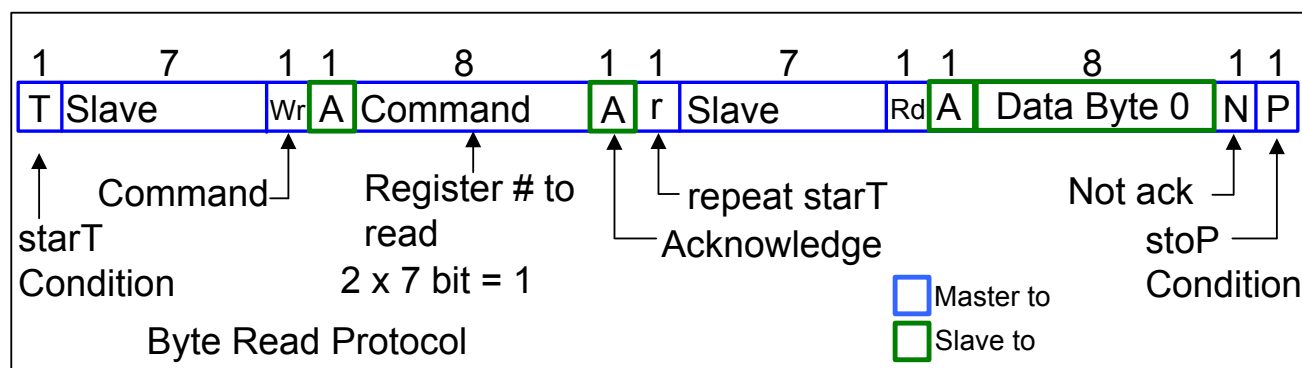

Figure 7. Byte Read Protocol

#### 4.1.2. Byte Write

Figure 8 illustrates a simple, typical byte write. For byte operation, the 2 x 7th bit of the command byte must be set. For block operations, the 2 x 7th bit must be reset. If the bit is not set, the next byte must be the byte transfer count. The count can be between 1 and 32. It is not allowed to be zero or to exceed 32.

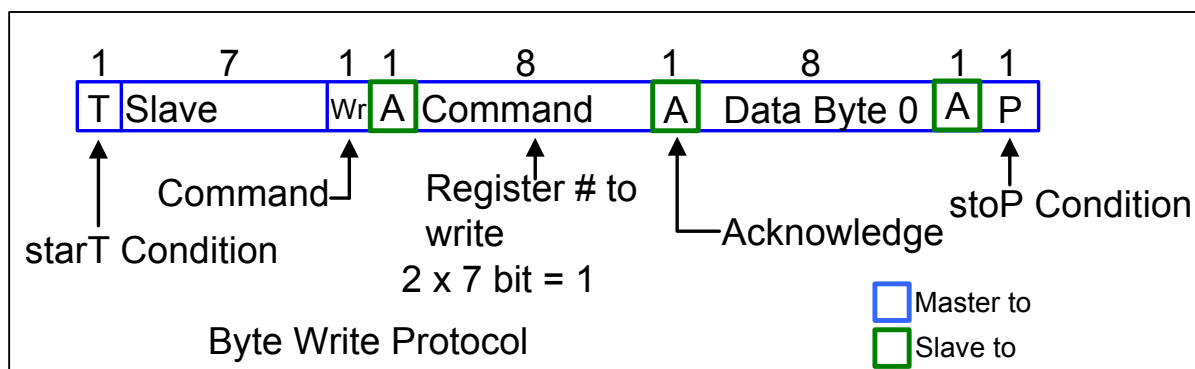

Figure 8. Byte Write Protocol

## 4.2. Block Read/Write

### 4.2.1. Block Read

After the slave address is sent with the R/W condition bit set, the command byte is sent with the MSB = 0. The slave acknowledges the register index in the command byte. The master sends a repeat start function. After the slave acknowledges this, the slave sends the number of bytes it wants to transfer (>0 and <33). The master acknowledges each byte except the last and sends a stop function.

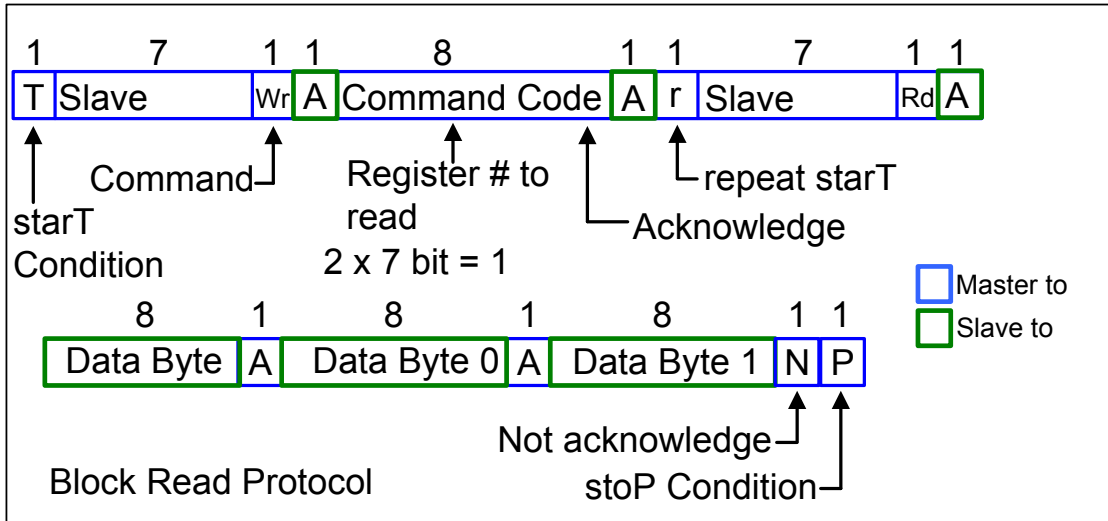

Figure 9. Block Read Protocol

### 4.2.2. Block Write

After the slave address is sent with the R/W condition bit not set, the command byte is sent with the MSB = 0. The lower seven bits indicate the register at which to start the transfer. If the command byte is 00h, the slave device will be compatible with existing block mode slave devices. The next byte of a write must be the count of bytes that the master will transfer to the slave device. The byte count must be greater than zero and less than 33. Following this byte are the data bytes to be transferred to the slave device. The slave device always acknowledges each byte received. The transfer is terminated after the slave sends the Ack and the master sends a stop function.

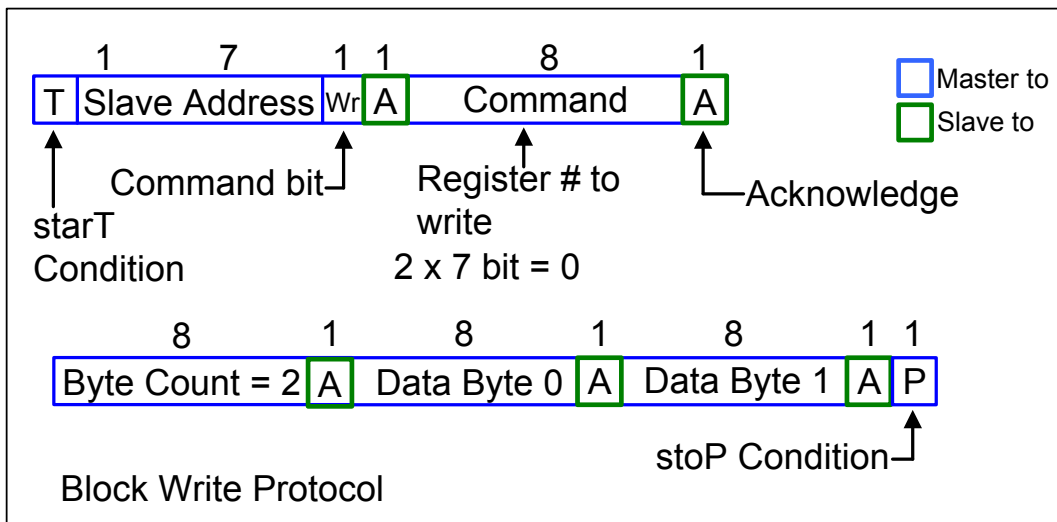

Figure 10. Block Write Protocol

### 4.3. Control Registers

Table 18. Byte 0: Frequency Select, Output Enable, PLL Mode Control Register

Bit	Description	If Bit = 0	If Bit = 1	Type	Default	Output(s) Affected
0	100M_133M# Frequency Select	133 MHz	100 MHz	R	Latched at power up	DIF[11:0]
1	PLL Mode 0	See PLL Operating Mode Readback Table		RW	1	
2	PLL Mode 1			RW	1	
3	PLL Software Enable	HW Latch	SMBUS Control	RW	0	
4	Reserved				0	
5	Reserved				0	
6	PLL Mode 0	See PLL Operating Mode Readback Table		R	Latched at power up	
7	PLL Mode 1	See PLL Operating Mode Readback Table		R	Latched at power up	

**Note:** Byte 0, bit\_[3:1] are BW PLL SW enable for the Si53108. Setting bit 3 to 1 allows the user to override the Latch value from pin 5 via use of bits 2 and 1. Use the values from the PLL Operating Mode Readback Table. Note that Bits 7 and 6 will keep the value originally latched on pin 5. A warm reset of the system will have to be accomplished if the user changes these bits.

**Table 19. Byte 1: Output Enable Control Register**

Bit	Description	If Bit = 0	If Bit = 1	Type	Default	Output(s) Affected
0	Reserved				1	
1	Output Enable DIF 0	Low/Low for Si53108	Enabled	RW	1	DIF[0]
2	Output Enable DIF 1	Low/Low for Si53108	Enabled	RW	1	DIF[1]
3	Reserved				1	
4	Output Enable DIF 2	Low/Low for Si53108	Enabled	RW	1	DIF[2]
5	Output Enable DIF 3	Low/Low for Si53108	Enabled	RW	1	DIF[3]
6	Output Enable DIF 4	Low/Low for Si53108	Enabled	RW	1	DIF[4]
7	Output Enable DIF 5	Low/Low for Si53108	Enabled	RW	1	DIF[5]

**Note:** Output Control — “0” overrides  $\overline{OE}$  pin.

Table 20. Byte 2: Output Enable Control Register

Bit	Description	If Bit = 0	If Bit = 1	Type	Default	Output(s) Affected
0	Output Enable for DIF 6	Low/Low	Enabled	RW	1	DIF[6]
1	Reserved				1	
2	Output Enable for DIF 7	Low/Low	Enabled	RW	1	DIF[7]
3	Reserved				0	
4	Reserved				0	
5	Reserved				0	
6	Reserved				0	
7	Reserved				0	

Table 21. Byte 3: Reserved Control Register

Bit	Description	If Bit = 0	If Bit = 1	Type	Default	Output(s) Affected
0	Reserved				0	
1	Reserved				0	
2	Reserved				0	
3	Reserved				0	
4	Reserved				0	
5	Reserved				0	
6	Reserved				0	
7	Reserved				0	

**Table 22. Byte 4: Reserved Control Register**

Bit	Description	If Bit = 0	If Bit = 1	Type	Default	Output(s) Affected
0	Reserved				0	
1	Reserved				0	
2	Reserved				0	
3	Reserved				0	
4	Reserved				0	
5	Reserved				0	
6	Reserved				0	
7	Reserved				0	

**Table 23. Byte 5: Vendor/Revision Identification Control Register**

Bit	Description	If Bit = 0	If Bit = 1	Type	Default	Default
0	Vendor ID Bit 0			R	Vendor Specific	0
1	Vendor ID Bit 1			R	Vendor Specific	0
2	Vendor ID Bit 2			R	Vendor Specific	0
3	Vendor ID Bit 3			R	Vendor Specific	1
4	Revision Code Bit 0			R	Vendor Specific	0
5	Revision Code Bit 1			R	Vendor Specific	0
6	Revision Code Bit 2			R	Vendor Specific	0
7	Revision Code Bit 3			R	Vendor Specific	0

**Table 24. Byte 6: Device ID Control Register**

Bit	Description	If Bit = 0	If Bit = 1	Type	Default	Default
0	Device ID 0			R	1	0
1	Device ID 1			R	1	0
2	Device ID 2			R	1	0
3	Device ID 3			R	0	0
4	Device ID 4			R	0	0
5	Device ID 5			R	1	0
6	Device ID 6			R	1	0
7	Device ID 7 (MSB)			R	1	0

Table 25. Byte 7: Byte Count Register

Bit	Description	If Bit = 0	If Bit = 1	Type	Default	Output(s) Affected
0	BC0 - Writing to this register configures how many bytes will be read back			RW	0	
1	BC1 -Writing to this register configures how many bytes will be read back			RW	0	
2	BC2 -Writing to this register configures how many bytes will be read back			RW	0	
3	BC3 -Writing to this register configures how many bytes will be read back			RW	1	
4	BC4 -Writing to this register configures how many bytes will be read back			RW	0	
5	Reserved				0	
6	Reserved				0	
7	Reserved				0	

## 5. Power Filtering Example

### 5.1. Ferrite Bead Power Filtering

Silicon Labs recommends using a ferrite bead with characteristics matching Murata BLM15EG221SN1.

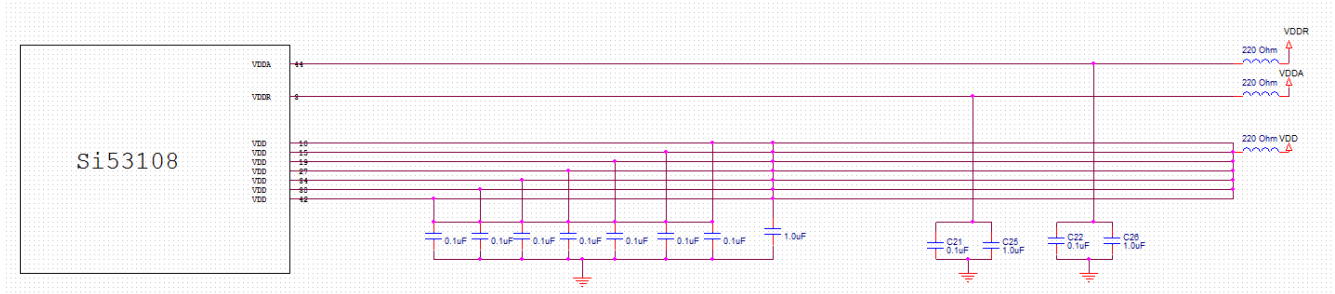
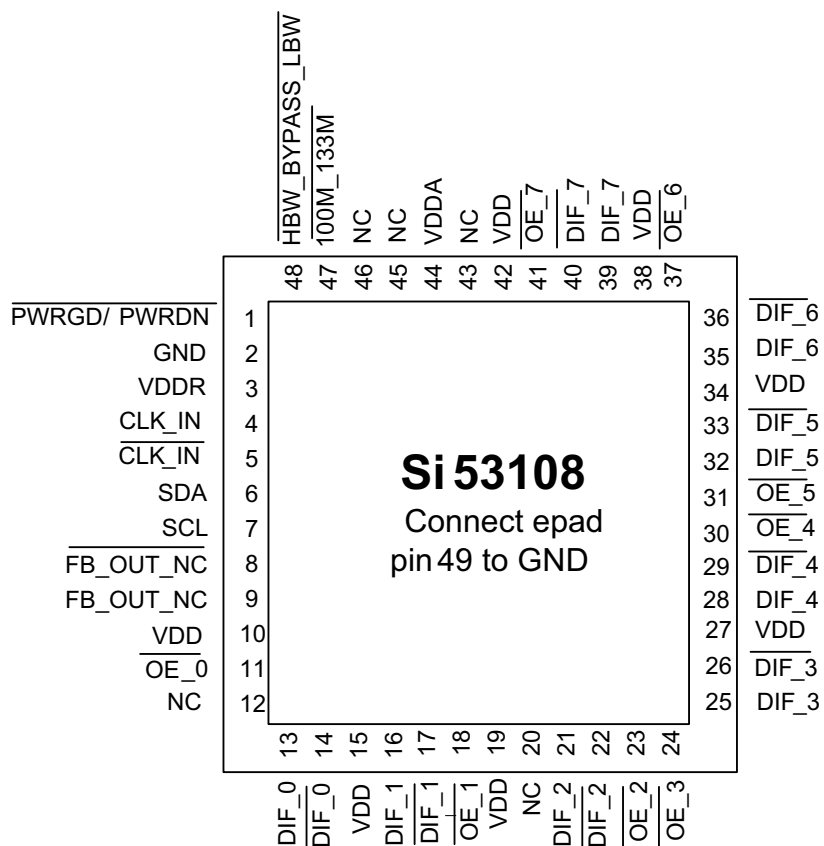

Figure 11. Recommended Si53108 Power Filtering

## 6. Pin Descriptions: 48-Pin QFN



**Table 26. Si53108 48-Pin QFN Descriptions**

Pin #	Name	Type	Description
1	$\overline{\text{PWRGD/PWRDN}}$	I	3.3 V LVTTTL input to power up or power down the device.
2	GND	GND	Connect this pin to ground.
3	VDDR	VDD	3.3 V power supply for differential input receiver. This VDDR should be treated as an analog power rail and filtered appropriately.
4	CLK_IN	I, DIF	0.7 V Differential input.
5	$\overline{\text{CLK\_IN}}$	I, DIF	0.7 V Differential input.
6	SDA	I/O	Open collector SMBus data.
7	SCL	I/O	SMBus slave clock input.
8	$\overline{\text{FB\_OUT\_NC}}$	I/O	No connect. There are active signals on pin 8 and 9, do not connect anything to these pins.
9	FB_OUT_NC	I/O	No connect. There are active signals on pin 8 and 9, do not connect anything to these pins.
10	VDD	3.3 V	3.3 V power supply
11	$\overline{\text{OE\_0}}$	I, SE	3.3 V LVTTTL active low input for enabling differential outputs (default). Controls the corresponding output pair. Internal pull-down.
12	NC	-	Do not connect this pin to anything.
13	DIF_0	O, DIF	0.7 V Differential clock output. Default is 1:1.
14	$\overline{\text{DIF\_0}}$	O, DIF	0.7 V Differential clock output. Default is 1:1.
15	VDD	3.3 V	3.3 V power supply for outputs.
16	DIF_1	O, DIF	0.7 V Differential clock output. Default is 1:1.
17	$\overline{\text{DIF\_1}}$	O, DIF	0.7 V Differential clock output. Default is 1:1.
18	$\overline{\text{OE\_1}}$	I, SE	3.3 V LVTTTL active low input for enabling differential outputs (default). Controls the corresponding output pair. Internal pull-down.
19	VDD	3.3 V	3.3 V power supply
20	NC	-	Do not connect this pin to anything.
21	DIF_2	O, DIF	0.7 V Differential clock output. Default is 1:1.
22	$\overline{\text{DIF\_2}}$	O, DIF	0.7 V Differential clock output. Default is 1:1.
23	$\overline{\text{OE\_2}}$	I, SE	3.3 V LVTTTL active low input for enabling differential outputs (default). Controls the corresponding output pair. Internal pull-down.
24	$\overline{\text{OE\_3}}$	I, SE	3.3 V LVTTTL active low input for enabling differential outputs (default). Controls the corresponding output pair. Internal pull-down.
25	DIF_3	O, DIF	0.7 V Differential clock output. Default is 1:1.
26	$\overline{\text{DIF\_3}}$	O, DIF	0.7 V Differential clock output. Default is 1:1.

Table 26. Si53108 48-Pin QFN Descriptions

Pin #	Name	Type	Description
27	VDD	3.3 V	3.3 V power supply
28	DIF_4	O, DIF	0.7 V Differential clock output. Default is 1:1.
29	$\overline{\text{DIF}}_4$	O, DIF	0.7 V Differential clock output. Default is 1:1.
30	$\overline{\text{OE}}_4$	I, SE	3.3 V LVTTTL active low input for enabling differential outputs (default). Controls the corresponding output pair. Internal pull-down.
31	$\overline{\text{OE}}_5$	I, SE	3.3 V LVTTTL active low input for enabling differential outputs (default). Controls the corresponding output pair. Internal pull-down.
32	DIF_5	O, DIF	0.7 V Differential clock output. Default is 1:1.
33	$\overline{\text{DIF}}_5$	O, DIF	0.7 V Differential clock output. Default is 1:1.
34	VDD	3.3 V	3.3 V power supply
35	DIF_6	O, DIF	0.7 V Differential clock output. Default is 1:1.
36	$\overline{\text{DIF}}_6$	O, DIF	0.7 V Differential clock output. Default is 1:1.
37	$\overline{\text{OE}}_6$	I, SE	3.3 V LVTTTL active low input for enabling differential outputs (default). Controls the corresponding output pair. Internal pull-down.
38	VDD	3.3 V	3.3 V power supply
39	DIF_7	O, DIF	0.7 V Differential clock output. Default is 1:1.
40	$\overline{\text{DIF}}_7$	O, DIF	0.7 V Differential clock output. Default is 1:1.
41	$\overline{\text{OE}}_7$	I, SE	3.3 V LVTTTL active low input for enabling differential outputs (default). Controls the corresponding output pair. Internal pull-down.
42	VDD	3.3 V	3.3 V power supply
43	NC	-	Do not connect this pin to anything.
44	VDDA	3.3V	3.3 V power supply for PLL.
45	NC	-	Do not connect this pin to anything.
46	NC	-	Do not connect this pin to anything.
47	$\overline{100\text{M\_}133\text{M}}$	I,SE	3.3 V tolerant inputs for input/output frequency selection. An external pull-up or pull-down resistor is attached to this pin to select the input/output frequency. High = 100 MHz output Low = 133 MHz output
48	$\overline{\text{HBW\_BYPASS\_LBW}}$	I, SE	Tri-Level input for selecting the PLL bandwidth or bypass mode. High = High BW mode Med = Bypass mode Low = Low BW mode
49	GND	GND	Ground epad to GND.

# Si53108

---

## 7. Ordering Guide

Part Number	Package Type	Temperature
<b>Lead-free</b>		
Si53108-A01AGM	48-pin QFN	Extended, -40 to 85 °C
Si53108-A01AGMR	48-pin QFN—Tape and Reel	Extended, -40 to 85 °C

## 8. Package Outline

Figure 12 illustrates the package details for the Si53108. Table 27 lists the values for the dimensions shown in the illustration.

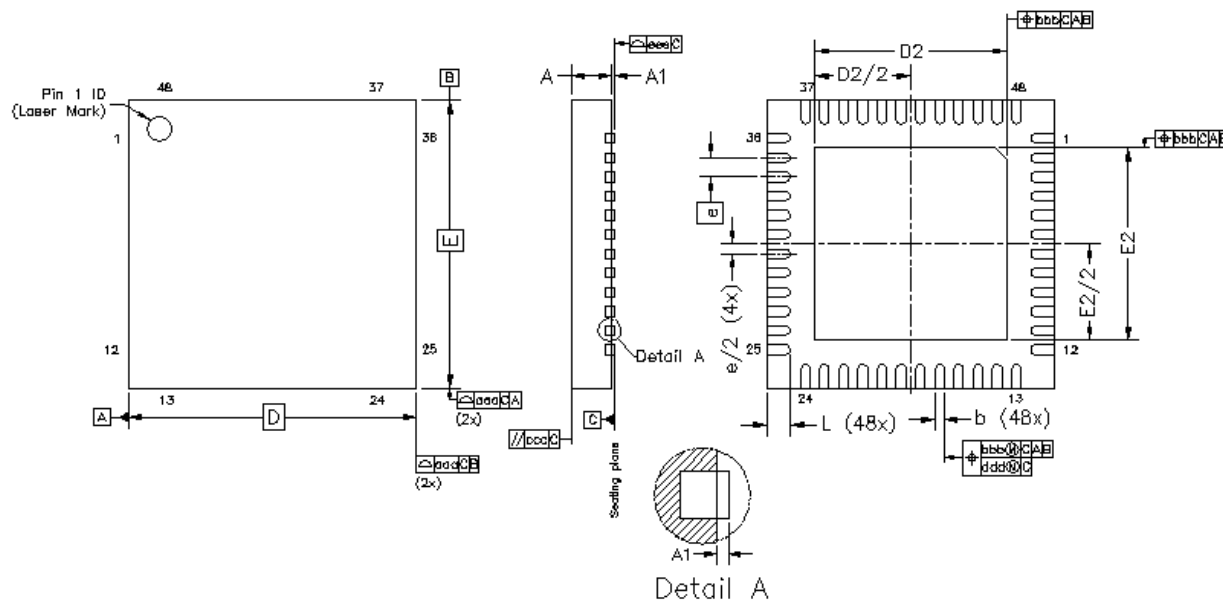

Figure 12. 48-Pin Quad Flat No Lead (QFN) Package

Table 27. Package Diagram Dimensions

Dimension	Min	Nom	Max
A	0.80	0.85	0.90
A1	0.00	0.02	0.05
b	0.15	0.20	0.25
D	6.00 BSC.		
D2	3.90	4.00	4.10
e	0.40 BSC.		
E	6.00 BSC.		
E2	3.90	4.00	4.10
L	0.30	0.40	0.50
aaa	0.10		
bbb	0.10		
ccc	0.10		
<b>Notes:</b>			
1. All dimensions shown are in millimeters (mm) unless otherwise noted.			
2. Dimensioning and Tolerancing per ANSI Y14.5M-1994.			
3. This drawing conforms to JEDEC outline MO-220			
4. Recommended card reflow profile is per the JEDEC/IPC J-STD-020 specification for Small Body Components.			

**Table 27. Package Diagram Dimensions**

<b>Dimension</b>	<b>Min</b>	<b>Nom</b>	<b>Max</b>
ddd		0.10	
eee		0.08	
<b>Notes:</b> <ol style="list-style-type: none"><li>1. All dimensions shown are in millimeters (mm) unless otherwise noted.</li><li>2. Dimensioning and Tolerancing per ANSI Y14.5M-1994.</li><li>3. This drawing conforms to JEDEC outline MO-220</li><li>4. Recommended card reflow profile is per the JEDEC/IPC J-STD-020 specification for Small Body Components.</li></ol>			

## 9. Land Pattern

Figure 13 illustrates the recommended land pattern details for the Si53108 in a 48-pin QFN package. Table 28 lists the values for the dimensions shown in the illustration.

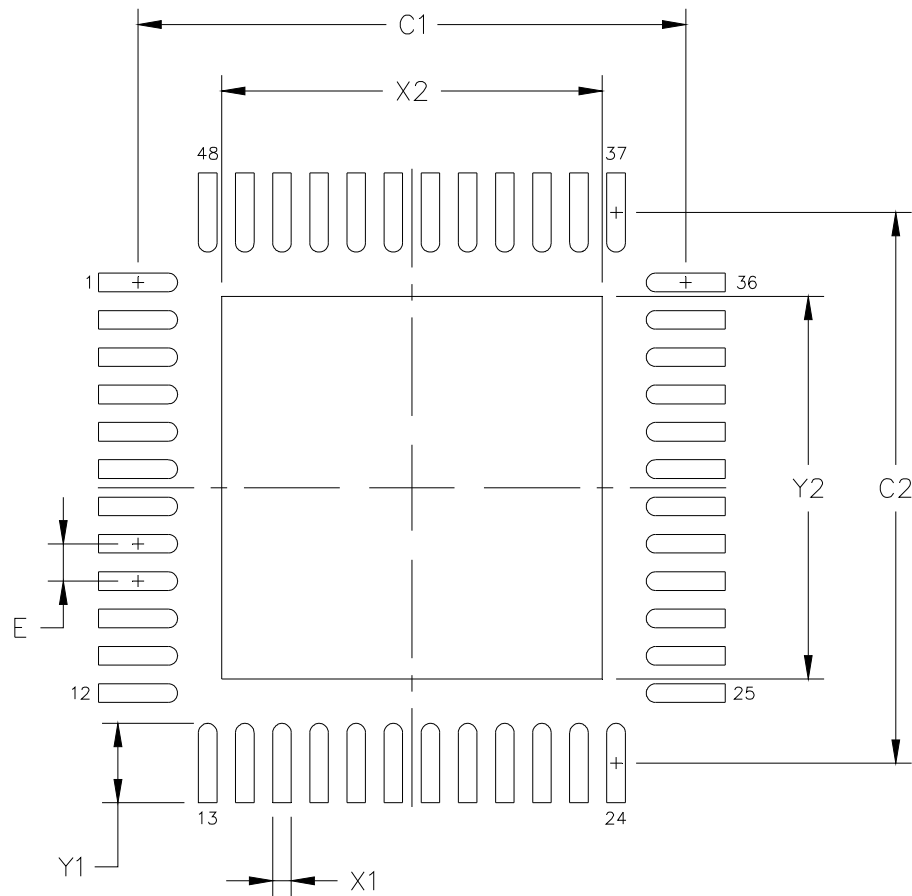

**Figure 13. Land Pattern**

**Table 28. PCB Land Pattern Dimensions**

Dimension	mm
C1	5.90
C2	5.90
E	0.40
X1	0.20
Y1	0.85
X2	4.10
Y2	4.10

**Notes:**

**General**

1. All dimensions shown are in millimeters (mm).
2. This Land Pattern Design is based on the IPC-7351 guidelines.
3. All dimensions shown are at Maximum Material Condition (MMC). Least Material Condition (LMC) is calculated based on a Fabrication Allowance of 0.05 mm.

**Solder Mask Design**

4. All metal pads are to be non-solder mask defined (NSMD). Clearance between the solder mask and the metal pad is to be 60  $\mu\text{m}$  minimum, all the way around the pad.

**Stencil Design**

5. A stainless steel, laser-cut and electro-polished stencil with trapezoidal walls should be used to assure good solder paste release.
6. The stencil thickness should be 0.125 mm (5 mils).
7. The ratio of stencil aperture to land pad size should be 1:1 for all perimeter pads.
8. A 3x3 array of 1.0 mm square openings on a 1.5 mm pitch should be used for the center ground pad.

**Card Assembly**

9. A No-Clean, Type-3 solder paste is recommended.
10. The recommended card reflow profile is per the JEDEC/IPC J-STD-020 specification for Small Body Components.

## CONTACT INFORMATION

### Silicon Laboratories Inc.

400 West Cesar Chavez  
Austin, TX 78701  
Tel: 1+(512) 416-8500  
Fax: 1+(512) 416-9669  
Toll Free: 1+(877) 444-3032

Please visit the Silicon Labs Technical Support web page:

<https://www.siliconlabs.com/support/pages/contacttechnicalsupport.aspx>  
and register to submit a technical support request.

### Patent Notice

Silicon Labs invests in research and development to help our customers differentiate in the market with innovative low-power, small size, analog-intensive mixed-signal solutions. Silicon Labs' extensive patent portfolio is a testament to our unique approach and world-class engineering team.

The information in this document is believed to be accurate in all respects at the time of publication but is subject to change without notice. Silicon Laboratories assumes no responsibility for errors and omissions, and disclaims responsibility for any consequences resulting from the use of information included herein. Additionally, Silicon Laboratories assumes no responsibility for the functioning of undescribed features or parameters. Silicon Laboratories reserves the right to make changes without further notice. Silicon Laboratories makes no warranty, representation or guarantee regarding the suitability of its products for any particular purpose, nor does Silicon Laboratories assume any liability arising out of the application or use of any product or circuit, and specifically disclaims any and all liability, including without limitation consequential or incidental damages. Silicon Laboratories products are not designed, intended, or authorized for use in applications intended to support or sustain life, or for any other application in which the failure of the Silicon Laboratories product could create a situation where personal injury or death may occur. Should Buyer purchase or use Silicon Laboratories products for any such unintended or unauthorized application, Buyer shall indemnify and hold Silicon Laboratories harmless against all claims and damages.

Silicon Laboratories and Silicon Labs are trademarks of Silicon Laboratories Inc.  
Other products or brandnames mentioned herein are trademarks or registered trademarks of their respective holders.