

**TECHNICAL DATA SHEET**

This range of ECO LED beacons is a cost effective solution for local signalling applications where long life and low maintenance are required. The unit incorporate 8 off Surface Mount LED's giving 360 degree light output around the vertical axis. The ES design lends itself for use in temporary signalling locations where a warning or hazard is not normally present, or has the ability to be installed in an area using existing electrical lighting points, avoiding any additional wiring.

Part Code:	Voltage:	Light Source:	Current:
LEDES100-05	85-380v Dc --- 85-280v Ac ~	8 SMT LEDs	35mA @ 230v Ac

For Lens colours add: 01 Amber, 02 Red and 04 Green

**Key Features Include:**

- Ingress Protection: IP65
- Operating Temperature Range: -25 +55°C
- Enclosure Materials: UV Stable Polycarbonate Lens. UV Stable ABS Base.
- AC Supply: 50/60 Hz

Moflash part code S00591 Issue 2

**INSTALLATION &  
TECHNICAL INFORMATION**

PLEASE READ PRIOR TO INSTALLATION



**LED ES 100 Series - E27 Edison Screw (LED Array)**

VISUAL SIGNALLING DEVICES

APPROVALS AND  
CONFORMITIES



Website: [www.moflash.com](http://www.moflash.com)

Email: [technical@moflash.co.uk](mailto:technical@moflash.co.uk)

## LED ES 100 Series

### INSTALLATION DATA SHEET

If supplied with lens pre-fitted, remove the 2 x M4 screws that secure the lens to the base.

Select jumper link position on PCB, required for control functionality (see cable connection below and diagram 1)

Make sure that the base 'O' ring is in position before re-fitting the lens to the base. Ensure the two lens screws are tightened fully and that a good all round seal is made between the base and lens.

Screw the beacon into an E27 type light fitting for use.

### Cable Connection

A jumper link on the PCB (see diagram 1) pre-sets the unit to either static mode (permanently on) or flashing mode, once the unit is energised. With the jumper link in place, the unit is in flash mode only. If the jumper link is removed the unit is in static mode.

### General Installation Notes

- Installation must be carried out in accordance with the latest codes & regulations by a qualified electrician
- Ensure power is disconnected prior to installation or maintenance
- Environmental exposure conditions during installation should be dry, not moist or wet
- The lens of the unit is polycarbonate plastic. Do not clean with petroleum based cleaners
- Avoid mounting the beacon where it will be subject to excessive vibration

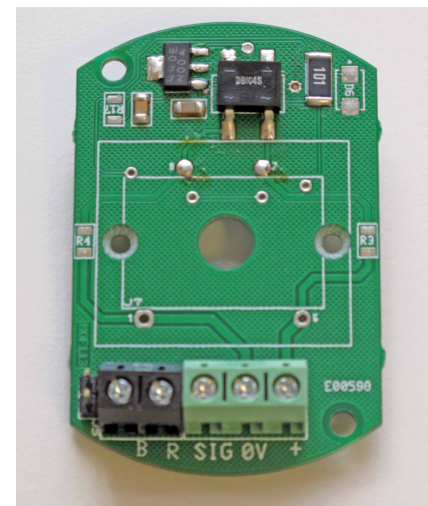
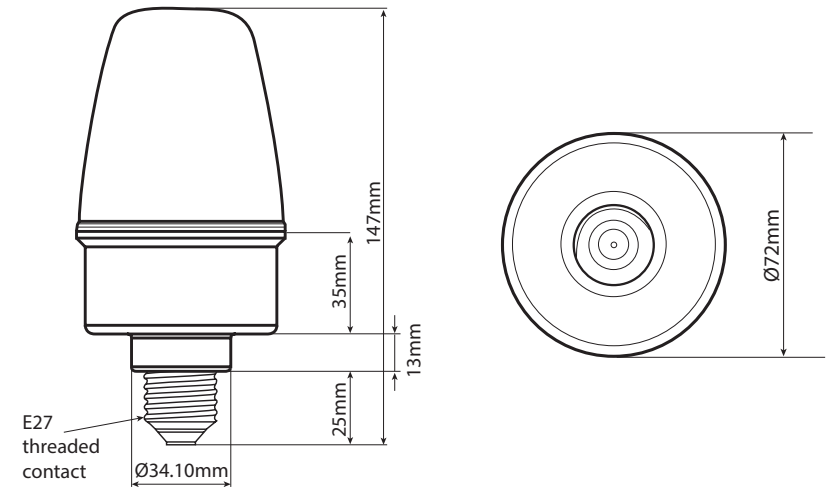

Diagram 1

