

ECM-LX800D

3.5" AMD LX800 Micro Module

User's Manual

1st Ed – 11 December 2008

FCC Statement



THIS DEVICE COMPLIES WITH PART 15 FCC RULES. OPERATION IS SUBJECT TO THE FOLLOWING TWO CONDITIONS:

(1) THIS DEVICE MAY NOT CAUSE HARMFUL INTERFERENCE.

(2) THIS DEVICE MUST ACCEPT ANY INTERFERENCE RECEIVED INCLUDING INTERFERENCE THAT MAY CAUSE UNDESIRE OPERATION.

THIS EQUIPMENT HAS BEEN TESTED AND FOUND TO COMPLY WITH THE LIMITS FOR A CLASS "A" DIGITAL DEVICE, PURSUANT TO PART 15 OF THE FCC RULES.

THESE LIMITS ARE DESIGNED TO PROVIDE REASONABLE PROTECTION AGAINST HARMFUL INTERFERENCE WHEN THE EQUIPMENT IS OPERATED IN A COMMERCIAL ENVIRONMENT. THIS EQUIPMENT GENERATES, USES, AND CAN RADIATE RADIO FREQUENCY ENERGY AND, IF NOT INSTALLED AND USED IN ACCORDANCE WITH THE INSTRUCTION MANUAL, MAY CAUSE HARMFUL INTERFERENCE TO RADIO COMMUNICATIONS.

OPERATION OF THIS EQUIPMENT IN A RESIDENTIAL AREA IS LIKELY TO CAUSE HARMFUL INTERFERENCE IN WHICH CASE THE USER WILL BE REQUIRED TO CORRECT THE INTERFERENCE AT HIS OWN EXPENSE.

Notice

This guide is designed for experienced users to setup the system within the shortest time. For detailed information, please always refer to the electronic user's manual.

Copyright Notice

Copyright © 2007-2008 Aualue Technology Inc., ALL RIGHTS RESERVED.

No part of this document may be reproduced, copied, translated, or transmitted in any form or by any means, electronic or mechanical, for any purpose, without the prior written permission of the original manufacturer.

Trademark Acknowledgement

Brand and product names are trademarks or registered trademarks of their respective owners.

Disclaimer

Aualue Technology Inc. reserves the right to make changes, without notice, to any product, including circuits and/or software described or contained in this manual in order to improve design and/or performance. Aualue Technology assumes no responsibility or liability for the use of the described product(s), conveys no license or title under any patent, copyright, or masks work rights to these products, and makes no representations or warranties that these products are free from patent, copyright, or mask work right infringement, unless otherwise specified. Applications that are described in this manual are for illustration purposes only. Aualue Technology Inc. makes no representation or warranty that such application will be suitable for the specified use without further testing or modification.

Life Support Policy

Aualue Technology's PRODUCTS ARE NOT FOR USE AS CRITICAL COMPONENTS IN LIFE SUPPORT DEVICES OR SYSTEMS WITHOUT THE PRIOR WRITTEN APPROVAL OF Aualue Technology Inc.

As used herein:

1. Life support devices or systems are devices or systems which, (a) are intended for surgical implant into body, or (b) support or sustain life and whose failure to perform, when properly used in accordance with instructions for use provided in the labeling, can be reasonably expected to result in significant injury to the user.
2. A critical component is any component of a life support device or system whose failure to perform can be reasonably expected to cause the failure of the life support device or system, or to affect its safety or effectiveness.

A Message to the Customer

Aualue Customer Services

Each and every Aualue's product is built to the most exacting specifications to ensure reliable performance in the harsh and demanding conditions typical of industrial environments. Whether your new Aualue device is destined for the laboratory or the factory floor, you can be assured that your product will provide the reliability and ease of operation for which the name Aualue has come to be known.

Your satisfaction is our primary concern. Here is a guide to Aualue's customer services. To ensure you get the full benefit of our services, please follow the instructions below carefully.

Technical Support

We want you to get the maximum performance from your products. So if you run into technical difficulties, we are here to help. For the most frequently asked questions, you can easily find answers in your product documentation. These answers are normally a lot more detailed than the ones we can give over the phone. So please consult the user's manual first.

To receive the latest version of the user's manual; please visit our Web site at:

<http://www.aualue.com.tw/>

If you still cannot find the answer, gather all the information or questions that apply to your problem, and with the product close at hand, call your dealer. Our dealers are well trained and ready to give you the support you need to get the most from your Aualue's products. In fact, most problems reported are minor and are able to be easily solved over the phone.

In addition, free technical support is available from Aualue's engineers every business day. We are always ready to give advice on application requirements or specific information on the installation and operation of any of our products. Please do not hesitate to call or e-mail us.

Headquarters

Avalue Technology Inc.
7F, 228, Lian-cheng Road,
Chung Ho City, Taipei,
Taiwan
Tel : +886-2-8226-2345
Fax : +886-2-8226-2777

Europe Branch Office

Avalue Europe A/S
Nordre Strandvej 13,
3480 Fredensborg,
Denmark
Tel : +45-7025-0310
Fax : +45-4975-5026

Information: sales@avalue.com.tw
Service: service@avalue.com.tw

Information: sales.europe@avalue.com.tw
Service: service.europe@avalue.com.tw

China Branch Office

Avalue Technology Shanghai Inc.
Room 909, 9F, Section B, No.900,
Yisan Road, Caohejing Hi-tech Park,
Shanghai 200233, China
Tel : +86-21-5423-4170
Fax : +86-21-5423-4171

US Branch Office

Avalue Technology Inc.
Suite 210, 200 Tornillo Way,
Tinton Falls, NJ 07712
USA
Tel: +1-732-578-0200
Fax: +1-732-578-0250

Information: sales.china@avalue.com.cn
Service: service@avalue.com.tw

Information: sales@avalue-usa.com
Service: support@avalue-usa.com

Product Warranty

Aualue warrants to you, the original purchaser, that each of its products will be free from defects in materials and workmanship for two years from the date of purchase.

This warranty does not apply to any products which have been repaired or altered by persons other than repair personnel authorized by Aualue, or which have been subject to misuse, abuse, accident or improper installation. Aualue assumes no liability under the terms of this warranty as a consequence of such events. Because of Aualue's high quality-control standards and rigorous testing, most of our customers never need to use our repair service. If any of Aualue's products is defective, it will be repaired or replaced at no charge during the warranty period. For out-of-warranty repairs, you will be billed according to the cost of replacement materials, service time, and freight. Please consult your dealer for more details. If you think you have a defective product, follow these steps:

1. Collect all the information about the problem encountered. (For example, CPU type and speed, Aualue's products model name, hardware & BIOS revision number, other hardware and software used, etc.) Note anything abnormal and list any on-screen messages you get when the problem occurs.
2. Call your dealer and describe the problem. Please have your manual, product, and any helpful information available.
3. If your product is diagnosed as defective, obtain an RMA (return material authorization) number from your dealer. This allows us to process your good return more quickly.
4. Carefully pack the defective product, a complete Repair and Replacement Order Card and a photocopy proof of purchase date (such as your sales receipt) in a shippable container. A product returned without proof of the purchase date is not eligible for warranty service.
5. Write the RMA number visibly on the outside of the package and ship it prepaid to your dealer.

Contents

1. Getting Started	9
1.1 Safety Precautions	9
1.2 Packing List.....	9
1.3 Document Amendment History	10
1.4 Manual Objectives.....	11
1.5 System Specifications	12
1.6 Architecture Overview—Block Diagram	14
2. Hardware Configuration	15
2.1 Product Overview.....	16
2.2 Installation Procedure	17
2.3 Jumper and Connector List.....	18
2.4 Setting Jumpers & Connectors	20
2.4.1 AT/ATX select (JAT/ATX).....	20
2.4.2 Clear CMOS (JBAT).....	20
2.4.3 COM1 – Ring, +5V, +12V power select(JRI1).....	21
2.4.4 Touch panel select (JTOUCH_SEL)	21
2.4.5 Audio Connector (JAUDIO).....	23
2.4.6 LCD inverter connector (JBKL)	22
2.4.7 Serial port 2 COM2 in RS-232 Mode (JCOM2).....	23
2.4.8 Serial port 2 in RS-422/485 Mode (JRS422/485)	24
2.4.9 LCD Backlight Brightness Adjustment Connector (JVR)	26
2.4.10 General purpose I/O connector (JDIO).....	26
2.4.11 IrDA Connector (JIR)	27
2.4.12 USB Connector 0 & 1 (JUSB).....	28
2.4.13 LVDS Connector (JLVDS)	29
2.4.14 TFT Panel Connector (JTFT).....	30
2.4.15 IDE Connector (IDE).....	32
2.4.16 VGA Connector (JVGA1).....	34
3. BIOS Setup	36
3.1 Starting Setup	37
3.2 Using Setup	38
3.3 Getting Help.....	39
3.4 In Case of Problems.....	39
3.5 Main Menu	40
3.5.1 Standard CMOS Features.....	41
3.5.2 Advanced BIOS Features	43

3.5.3	Advanced Chipset Features	46
3.5.4	Integrated Peripherals	48
3.5.4.1	IT8888 ISA Decode IO	50
3.5.4.2	IT8888 ISA Decode Memory	51
3.5.5.2	Power Management Setup	52
3.5.6.2	PnP / PCI Configuration	54
3.5.7.2	PC Health Status	55
3.5.8.2	Load Fail-Safe Defaults	55
3.5.9.2	Load Optimized Defaults	56
3.5.10.2	Set Supervisor / User Password	57
3.5.11.2	Save & Exit Setup	59
3.5.12.2	Exit Without Save	60
4	Drivers Installation	61
4.1	Install Audio Driver (For AMD LX800)	62
4.2	Install Chipset Driver (For AMD LX800)	64
4.3	Install PCI to ISA Bridge Driver (For ITE IT8888)	66
4.4	Install Display Driver (For AMD LX800)	68
4.5	Install Ethernet Driver (For Realtek RTL810x, RTL813x Family)	70
5	Mechanical Drawing	71
	Appendix A: Chipset Introduction	73
—	AMD LX800 & CS5536	74
—	Realtek ALC203 Audio Codec	76
—	Ethernet	76
	Realtek RTL8101L Ethernet Controller	76
—	ITE IT8888 PCI to ISA Bridge	77
—	Compact Flash Interface	77
	Appendix B: AWARD BIOS POST Messages	79
	Overview	80
	Post Beep	80
	Error Messages	80
1.	CMOS BATTERY HAS FAILED	80
2.	CMOS CHECKSUM ERROR	80
3.	DISK BOOT FAILURE, INSERT SYSTEM DISK AND PRESS ENTER	80
4.	DISKETTE DRIVES OR TYPES MISMATCH ERROR - RUN SETUP	80
5.	DISPLAY SWITCH IS SET INCORRECTLY	81
6.	DISPLAY TYPE HAS CHANGED SINCE LAST BOOT	81
7.	EISA Configuration Checksum Error PLEASE RUN EISA CONFIGURATION UTILITY	81
8.	EISA Configuration Is Not Complete PLEASE RUN EISA CONFIGURATION UTILITY	81
9.	ERROR ENCOUNTERED INITIALIZING HARD DRIVE	81
10.	ERROR INITIALIZING HARD DISK CONTROLLER	81

ECM-LX800D

11.	FLOPPY DISK CNTRLR ERROR OR NO CNTRLR PRESENT	81
12.	Invalid EISA Configuration PLEASE RUN EISA CONFIGURATION UTILITY	82
13.	KEYBOARD ERROR OR NO KEYBOARD PRESENT	82
14.	Memory Address Error at	82
15.	Memory parity Error at	82
16.	MEMORY SIZE HAS CHANGED SINCE LAST BOOT	82
17.	Memory Verify Error at	82
18.	OFFENDING ADDRESS NOT FOUND	82
19.	OFFENDING SEGMENT:	82
20.	PRESS A KEY TO REBOOT	83
21.	PRESS F1 TO DISABLE NMI, F2 TO REBOOT	83
22.	RAM PARITY ERROR - CHECKING FOR SEGMENT	83
23.	Should Be Empty But EISA Board Found PLEASE RUN EISA CONFIGURATION UTILITY	83
24.	Should Have EISA Board But Not Found PLEASE RUN EISA CONFIGURATION UTILITY	83
25.	Slot Not Empty	83
26.	SYSTEM HALTED, (CTRL-ALT-DEL) TO REBOOT	83
27.	Wrong Board In Slot PLEASE RUN EISA CONFIGURATION UTILITY	84
28.	FLOPPY DISK(S) fail (80) → Unable to reset floppy subsystem.....	84
29.	FLOPPY DISK(S) fail (40) → Floppy Type mismatch.....	84
30.	Hard Disk(s) fail (80) → HDD reset failed.....	84
31.	Hard Disk(s) fail (40) → HDD controller diagnostics failed.....	84
32.	Hard Disk(s) fail (20) → HDD initialization error.....	84
33.	Hard Disk(s) fail (10) → Unable to recalibrate fixed disk.....	84
34.	Hard Disk(s) fail (08) → Sector Verify failed.....	84
35.	Keyboard is locked out - Unlock the key.....	84
36.	Keyboard error or no keyboard present.....	84
37.	Manufacturing POST loop.....	84
38.	BIOS ROM checksum error - System halted.....	84
39.	Memory test fail.....	84
40.	POST Codes	85

1. Getting Started

1.1 Safety Precautions

Warning!



Always completely disconnect the power cord from your chassis whenever you work with the hardware. Do not make connections while the power is on. Sensitive electronic components can be damaged by sudden power surges. Only experienced electronics personnel should open the PC chassis.

Caution!



Always ground yourself to remove any static charge before touching the CPU card. Modern electronic devices are very sensitive to static electric charges. As a safety precaution, use a grounding wrist strap at all times. Place all electronic components in a static-dissipative surface or static-shielded bag when they are not in the chassis.

1.2 Packing List

Before you begin installing your single board, please make sure that the following materials have been shipped:

- 1 x ECM-LX800D AMD Geode LX800 Micro Module
- 1 x Quick Installation Guide for ECM-LX800D
- 1 x DVD-ROM contains the followings:
 - User's Manual (this manual in PDF file)
 - Ethernet driver and utilities
 - VGA drivers and utilities
 - Audio drivers and utilities
- 1 x Cable set contains the followings:
 - 1 x Daughter board support Audio/2 x USB (P/N:E9697000105R)
 - 1 x IDE HDD cable (44-pin, pitch 2.0mm)
 - 1 x Audio cable (10pin, 2.0mm pitch)
 - 1 x USB cable (10P/2.54mm-10P/2.0mm)
 - 1 x PS/2 Keyboard & mouse Y cable (6-pin, Mini-DIN)



If any of the above items is damaged or missing, contact your retailer.

1.3 Document Amendment History

Revision	Date	Comment
1 st	Dec., 2008	Initial Release

1.4 Manual Objectives

This manual describes in detail the Aualue Technology ECM-LX800D Single Board.







We have tried to include as much information as possible but we have not duplicated information that is provided in the standard IBM Technical References, unless it proved to be necessary to aid in the understanding of this board.

We strongly recommend that you study this manual carefully before attempting to interface with ECM-LX800D or change the standard configurations. Whilst all the necessary information is available in this manual we would recommend that unless you are confident, you contact your supplier for guidance.

Please be aware that it is possible to create configurations within the CMOS RAM that make booting impossible. If this should happen, clear the CMOS settings, (see the description of the Jumper Settings for details).

If you have any suggestions or find any errors concerning this manual and want to inform us of these, please contact our Customer Service department with the relevant details.

1.5 System Specifications

System 	
CPU	Onboard AMD Geode LX800 @ 0.9 W 500 MHz Note: Available in different CPU speeds by request
BIOS	Award 4 Mbit Flash BIOS
System Chipset	AMD Geode LX 800/CS5536
I/O Chip	Winbond W83627HG-AW
System Memory	Onboard 256MB DDR Memory, optional 512MB
SSD	One CompactFlash Type I/II socket
Watchdog Timer	Reset: 1 sec.~255 min. and 1 sec. or 1 min./step
Expansion	One PC/104 connector
I/O 	
MIO	1 x EIDE (Ultra DMA 100), 1 x RS-232, 1 x RS-232/422/485, 1 x K/B & Mouse, 1 x LPT
IrDA	115k bps, IrDA 1.0 compliant
USB	2 x USB 2.0 ports
DIO	8-bit GPIO
Display 	
Chipset	AMD Geode LX800 with integrated graphics engine
Display Memory	8/16/32/64/128/254 MB frame buffer using system memory
Resolution	CRT mode: 1920 x 1440 @ 32 bpp (85 Hz) TFT mode: 1600 x 1200 @ 16 bpp (60 Hz)
LVDS	Single channel 18-bit LVDS, optional 24-bit LVDS
VGA/LCD Interface	Support 18/24 bit TTL
Built-in Touch Screen (Optional) 	
Chipset	PenMount 6000
Touch Screen Interface	With 9-pin 2mm box header (can be selected to support 4/5/8-wire touch screen)
Audio 	
Chipset	AMD Geode CS5536
AC97 Codec	Realtek ALC203 supports 2 CH Audio
Audio Interface	Mic in, Line in, Line out, Audio in
Ethernet 	
LAN 1 & 2	Dual Realtek RTL8101L
Ethernet Interface	100Base-Tx Fast Ethernet compatible

Mechanical & Environmental 	
Power Requirement	+10V~+28V
Power Type	AT/ATX
Operation Temperature	0~60°C (32~140° F)
Operating Humidity	0%~90% relative humidity, non-condensing
Size (L x W)	5.7" x 4" (146 mm x 101 mm)
Weight	0.44 lbs (0.2 Kg)

1.6 Architecture Overview—Block Diagram

The following block diagram shows the architecture and main components of ECM-LX800D.

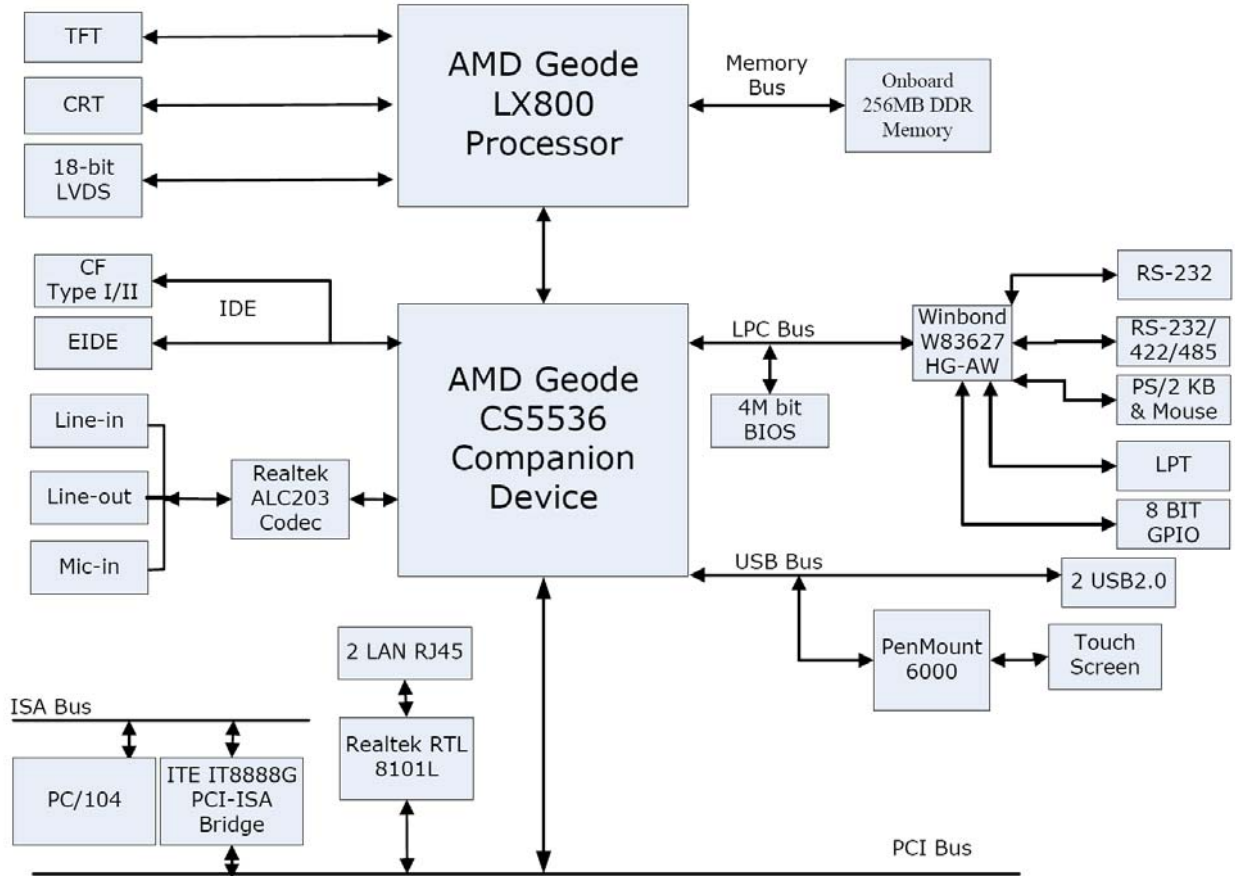

The following sections provide detail information about the functions provided onboard.

2. Hardware Configuration

2.1 Product Overview

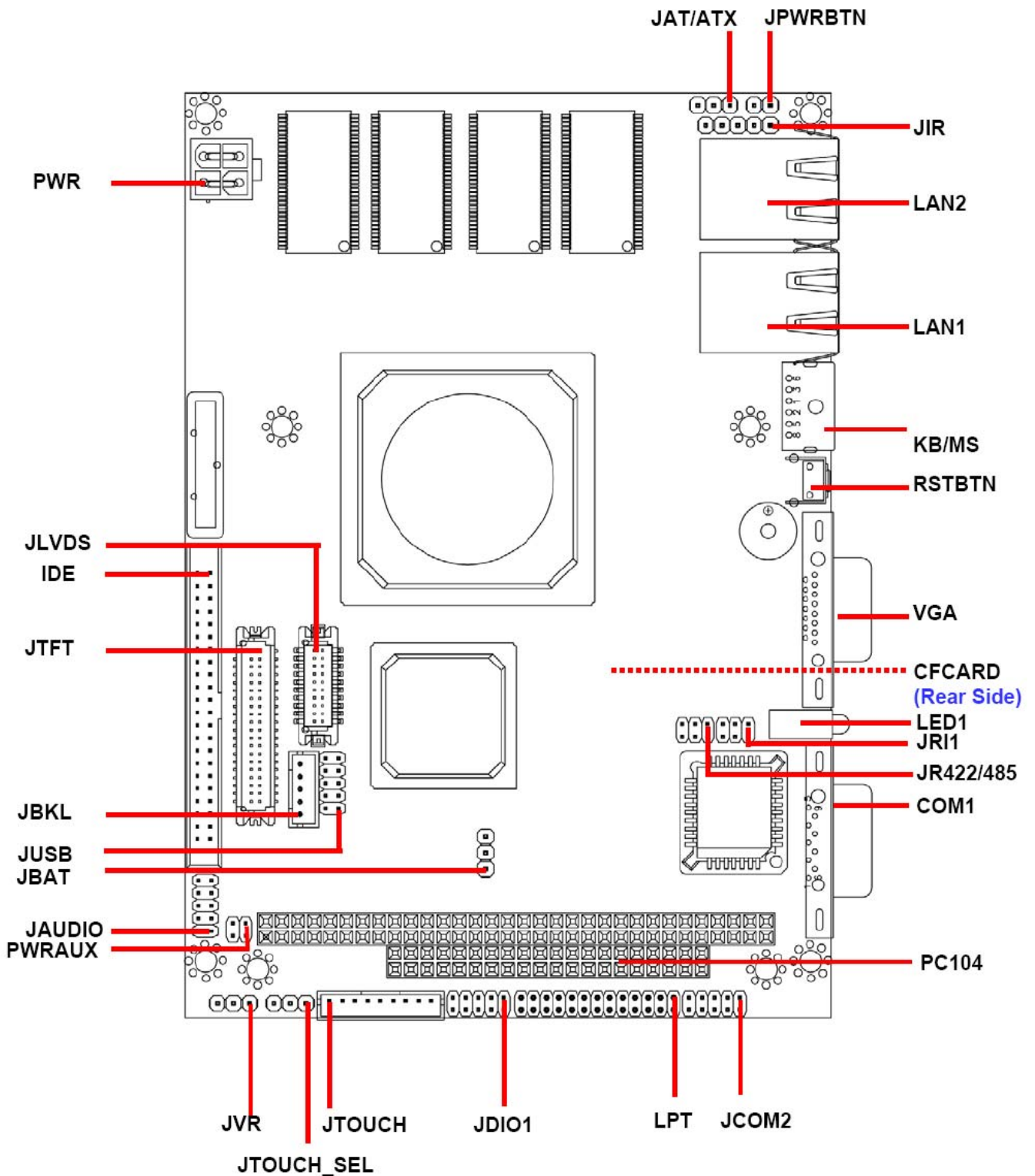

2.2 Installation Procedure

This chapter explains you the instructions of how to setup your system.

1. Turn off the power supply.
2. Insert the DIMM module (be careful with the orientation).
3. Insert all external cables for hard disk, floppy, keyboard, mouse, USB etc. except for flat panel. A CRT monitor must be connected in order to change CMOS settings to support flat panel.
4. Connect power supply to the board via the ATXPWR.
5. Turn on the power.
6. Enter the BIOS setup by pressing the delete key during boot up. Use the "LOAD BIOS DEFAULTS" feature. The **Integrated Peripheral Setup** and the **Standard CMOS Setup** Window must be entered and configured correctly to match the particular system configuration.
7. If TFT panel display is to be utilized, make sure the panel voltage is correctly set before connecting the display cable and turning on the power.



Make sure to unplug the power supply before adding or removing DIMMs or other system components. Failure to do so may cause severe damage to both the board and the components.



Note:

- (1) Please do not change any DDR SDRAM parameter in BIOS setup to increase your system's performance without acquiring technical information in advance.
- (2) Static electricity can damage the electronic components of the computer or optional boards. Before starting these procedures, ensure that you are discharged of static electricity by touching a grounded metal object briefly.

2.3 Jumper and Connector List

You can configure your board to match the needs of your application by setting jumpers. A jumper is the simplest kind of electric switch.

It consists of two metal pins and a small metal clip (often protected by a plastic cover) that slides over the pins to connect them. To “close” a jumper you connect the pins with the clip. To “open” a jumper you remove the clip. Sometimes a jumper will have three pins, labeled 1, 2, and 3. In this case, you would connect either two pins.

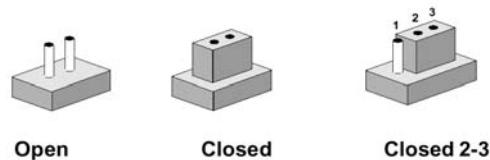

The jumper settings are schematically depicted in this manual as follows:



A pair of needle-nose pliers may be helpful when working with jumpers.

Connectors on the board are linked to external devices such as hard disk drives, a keyboard, or floppy drives. In addition, the board has a number of jumpers that allow you to configure your system to suit your application.

If you have any doubts about the best hardware configuration for your application, contact your local distributor or sales representative before you make any changes.

The following tables list the function of each of the board's jumpers and connectors.

Jumpers

Label	Function	Note
JAT/ATX	AT/ATX select	3 x 1 header, pitch 2.54mm
JBAT	Clear CMOS	3 x 1 header, pitch 2.54mm
JRI1	COM1 – Ring, +5V, +12V power select	3 x 2 header, pitch 2.0mm
JTOUCH_SEL	Touch panel select	3 x 1 header, pitch 2.54mm

Connectors

Label	Function	Note
CFCARD	CompactFlash card connector	Type I/II x 1
COM1	Serial port 1 connector	D-sub 9-pin, male
IDE	Primary IDE connector	22 x 2 header, pitch 2.0mm
JAUDIO	Audio connector	5 x 2 header, pitch 2.0mm
JBKL	LCD inverter connector	5 x 1 wafer, pitch 2.0mm
JCOM2	Serial port 2 in RS-232 mode connector	5 x 2 header, pitch 2.0mm
JDIO	General purpose I/O connector	5 x 2 header, pitch 2.0mm
JIR	IrDA connector	5 x 1 header, pitch 2.54mm
JLVDS	LVDS connector	10 x 2 header, pitch 1.25mm
JPWRBTN	Power button connector	2 x 1 header, pitch 2.54mm
JRS422/485	Serial port 2 in RS-422/485 mode connector	3 x 2 header, pitch 2.0mm
JTFT	TFT panel connector	HIROSE DF13-40DP-1.25V
JTOUCH	Touch panel connector	9 x 1 wafer, pitch 2.0mm
JUSB	USB connector 0 & 1	5 x 2 header, pitch 2.0mm
JVR	LCD backlight brightness adjustment connector	3 x 1 header, pitch 2.54mm
KB/MS	PS/2 keyboard & mouse connector	6-pin Mini-DIN
LAN1	RJ-45 Ethernet 1	
LAN2	RJ-45 Ethernet 2	
LED1	Power & HDD indicator	
LPT	Parallel port connector	13 x 2 header, pitch 2.0mm
PC-104	PC-104 connector	20 x 2 header, pitch 2.54mm
PC-104	PC-104 connector	32 x 2 header, pitch 2.54mm
PWR	Power connector	Wafer box 4P 4.2mm
PWRAUX	Auxiliary power connector	2 x 2 header, pitch 2.0mm
RSTBTN	Reset button	
SODIMM1	200-pin DDR SODIMM socket	
VGA	VGA connector	D-sub 15-pin, female

2.4 Setting Jumpers & Connectors

2.4.1 AT/ATX select (JAT/ATX)

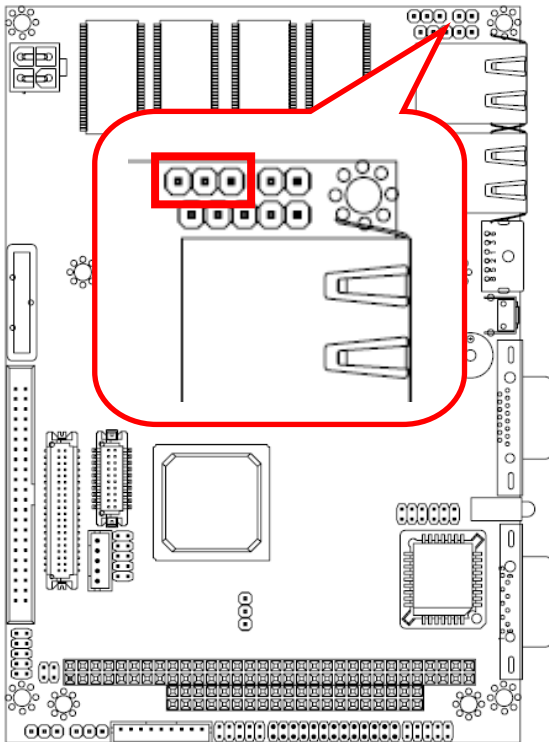

ATX*

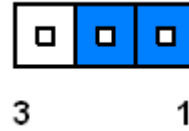

AT

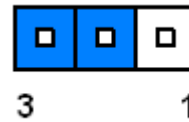

* Default

2.4.2 Clear CMOS (JBAT)

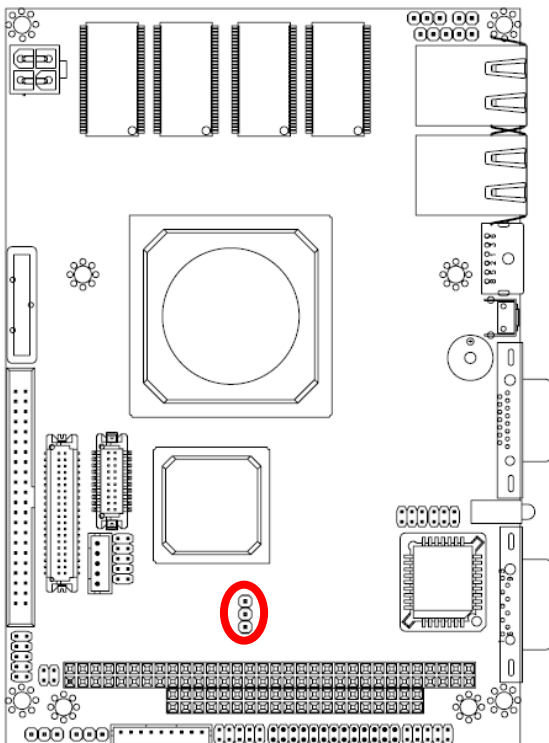

Protect*

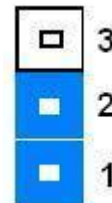

Clear CMOS

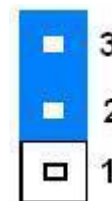

* Default

2.4.3 COM1 – Ring, +5V, +12V power select(JR11)

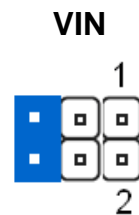
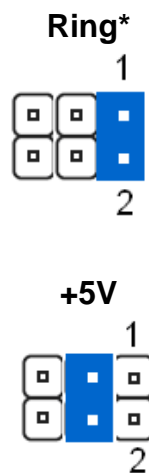
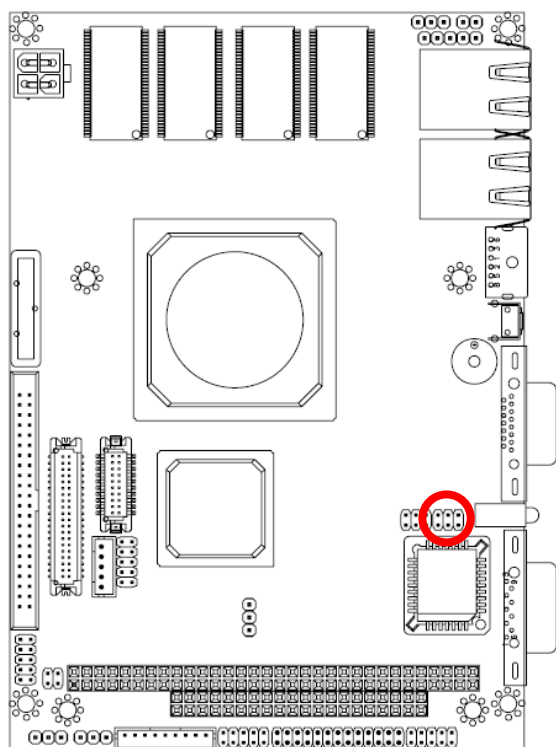

VIN=input voltage of power. (+10V~+28V)

* Default

2.4.4 Touch panel select (JTOUCH_SEL)

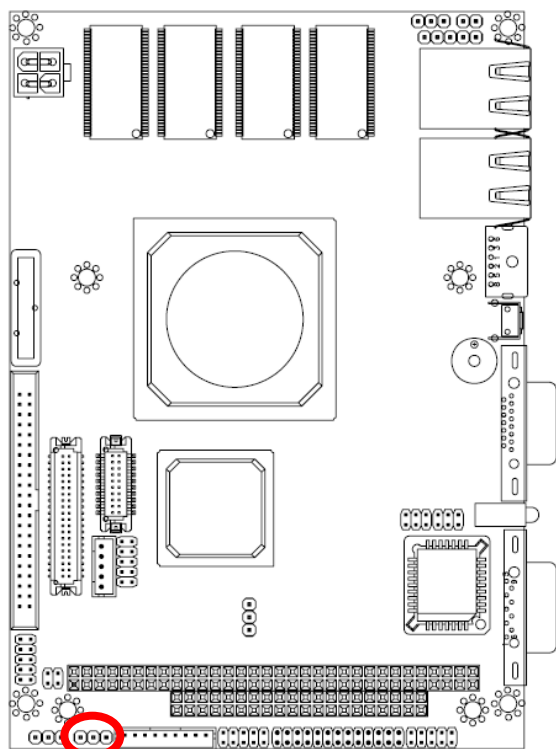

4 WIRE / 8 WIRE



5 WIRE*

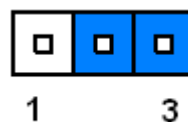

* Default

ECM-LX800D

2.4.5 LCD inverter connector (JBKL)

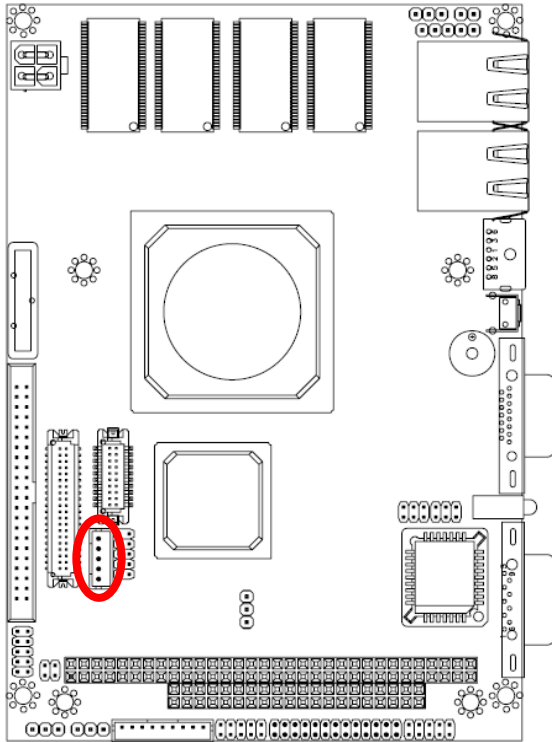

Signal	PIN
+5V	5
VR	4
ENBKL	3
GND	2
VIN	1

Note: The power input voltage (VIN) equals to output voltage of inverter.



Note:

For inverters with adjustable Backlight function, it is possible to control the LCD brightness through the VR signal controlled by JVR. Please see the JVR section for detailed circuitry information.

2.4.5.1 Signal Description – LCD Inverter Connector (JBKL)

Signal	Signal Description
VR	V _{adj} = 0.75V ~ 4.25V (Recommended: 4.7KΩ, >1/16W)
ENBKL	LCD backlight ON/OFF control signal

2.4.6 Audio Connector (JAUDIO)

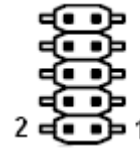
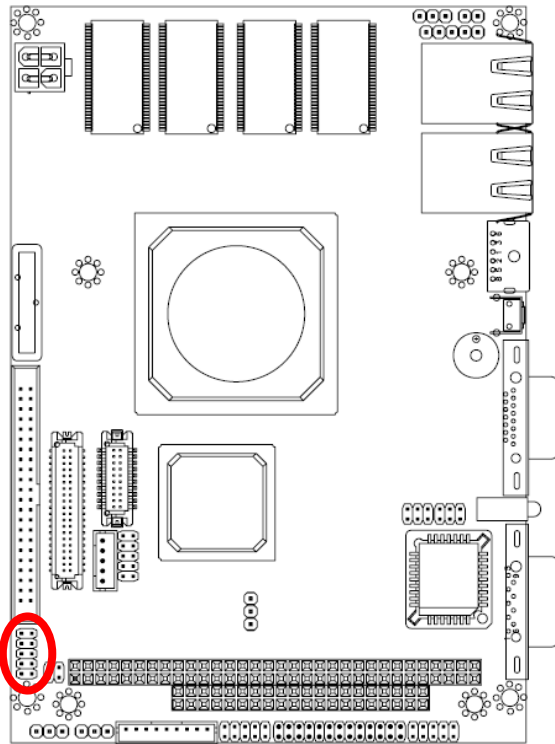

Signal	PIN	PIN	Signal
NC	10	9	NC
MIC-REF	8	7	MIC-IN
LIN_L	6	5	LIN_R
GND	4	3	GND
LINEOUT_L	2	1	LINEOUT_R

2.4.7 Serial Port 1 (COM1)

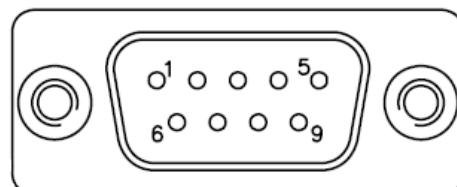
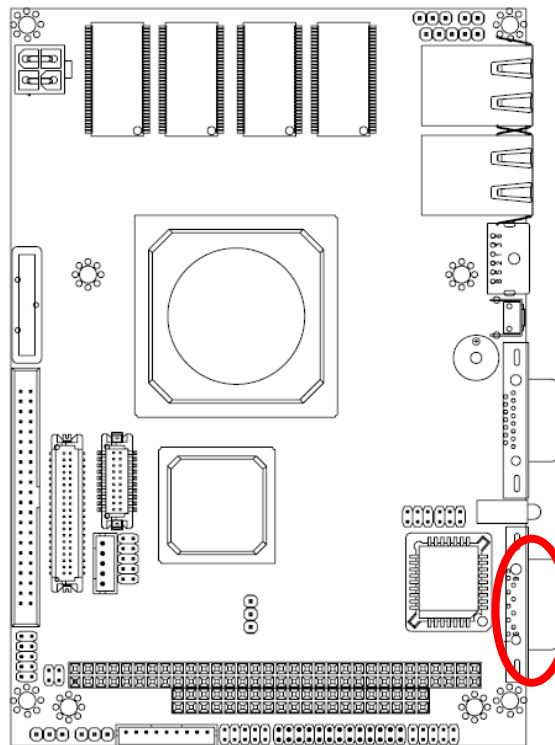

Signal	PIN	PIN	Signal
DCD	1	6	DSR
RXD	2	7	RTS
TXD	3	8	CTS
DTR	4	9	RI
GND	5		

ECM-LX800D

2.4.8 Serial port 2 COM2 in RS-232 Mode (JCOM2)

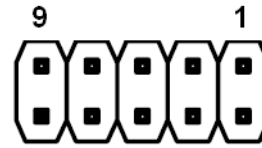
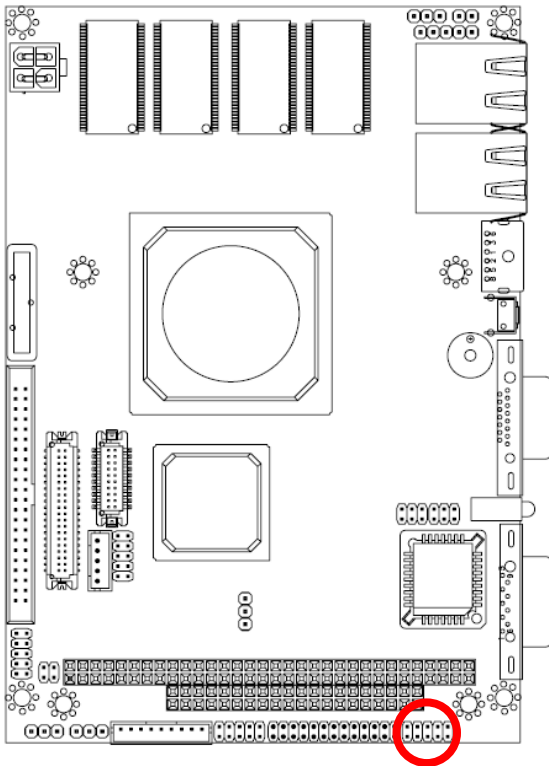

Signal	PIN	PIN	Signal
NC	10	9	RI
CTS	8	7	RTS
DSR	6	5	GND
DTR	4	3	TxD
RxD	2	1	DCD

2.4.9 Serial port 2 in RS-422/485 Mode (JRS422/485)

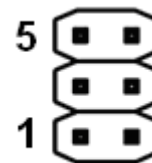
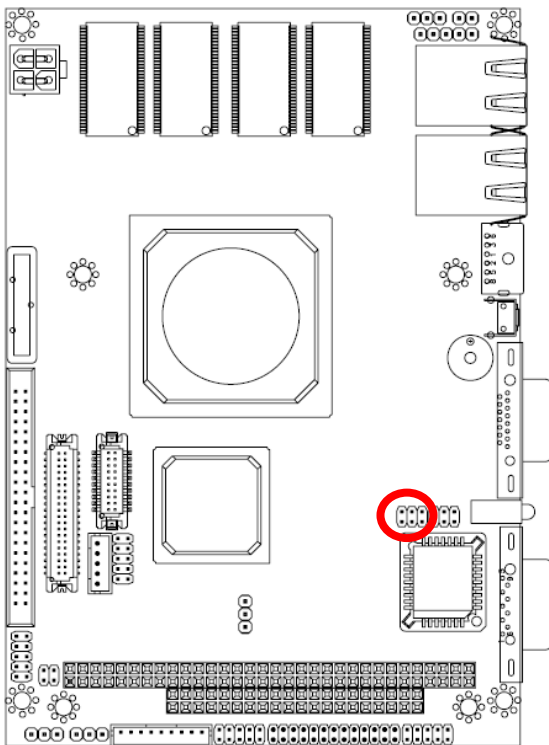

Signal	PIN	PIN	Signal
+5V	5	6	GND
TxD+	3	4	RxD+
TxD-	1	2	RxD-



Note:

JRS422/485 is available after modifying the mode of COM2 in BIOS setting.

2.4.8.1 Signal Description – Serial Port Connector (JCOM2, JRS422/485)

Signal	Signal Description
TxD	Serial output. This signal sends serial data to the communication link. The signal is set to a marking state on hardware reset when the transmitter is empty or when loop mode operation is initiated.
RxD	Serial input. This signal receives serial data from the communication link.
DTR	Data Terminal Ready. This signal indicates to the modem or data set that the on-board UART is ready to establish a communication link.
DSR	Data Set Ready. This signal indicates that the modem or data set is ready to establish a communication link.
RTS	Request To Send. This signal indicates to the modem or data set that the on-board UART is ready to exchange data.
CTS	Clear To Send. This signal indicates that the modem or data set is ready to exchange data.
DCD	Data Carrier Detect. This signal indicates that the modem or data set has detected the data carrier.
RI	Ring Indicator. This signal indicates that the modem has received a telephone ringing signal.



Do not select a mode different from the one used by the connected peripheral, as this may damage CPU board and/or peripheral.

The transmitter drivers in the port are short circuit protected by a thermal protection circuit. The circuit disables the drivers when the die temperature reaches 150 °C.

RS-422 mode is typically used in point to point communication. Data and control signal pairs should be terminated in the receiver end with a resistor matching the cable impedance (typical 100-120 Ω). The resistors could be placed in the connector housing.

RS-485 mode is typically used in multi drop applications, where more than 2 units are communicating. The data and control signal pairs should be terminated in each end of the communication line with a resistor matching the cable impedance (typical 100-120 Ω). Stubs to substations should be avoided.

ECM-LX800D

2.4.10 LCD Backlight Brightness Adjustment Connector (JVR)

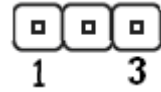
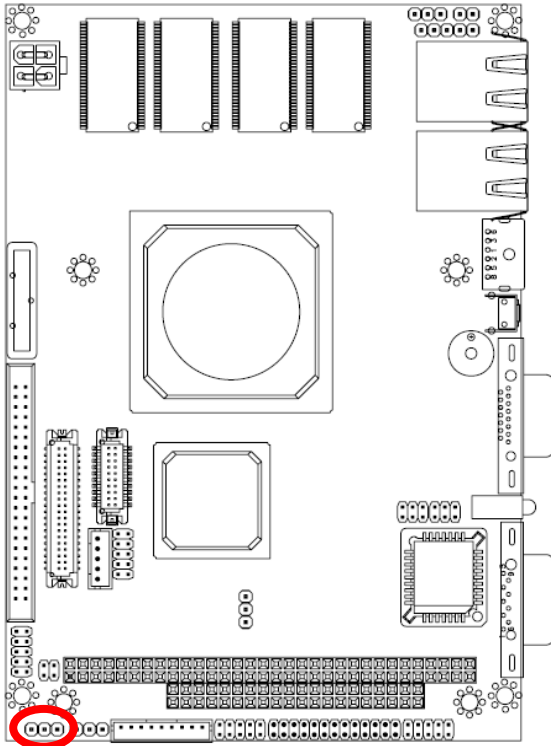

PIN	Signal
1	GND
2	VR
3	+5V

2.4.11 General purpose I/O connector (JDIO1)

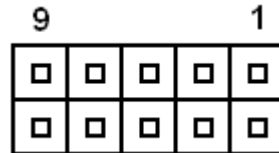
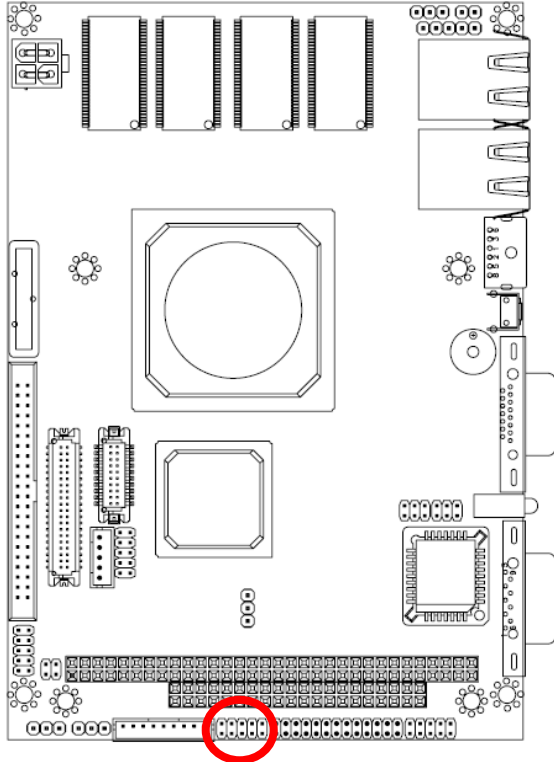

Signal	PIN	PIN	Signal
D10	1	2	DO0
D11	3	4	DO1
D12	5	6	DO2
D13	7	8	DO3
+5V	9	10	GND

2.4.10.1 Signal Description – General Purpose I/O Connector (JDIO1)

Signal	Signal Description
GP [0:3]	General purpose I/O port 1 bit 0~3.

2.4.12 IrDA Connector (JIR)

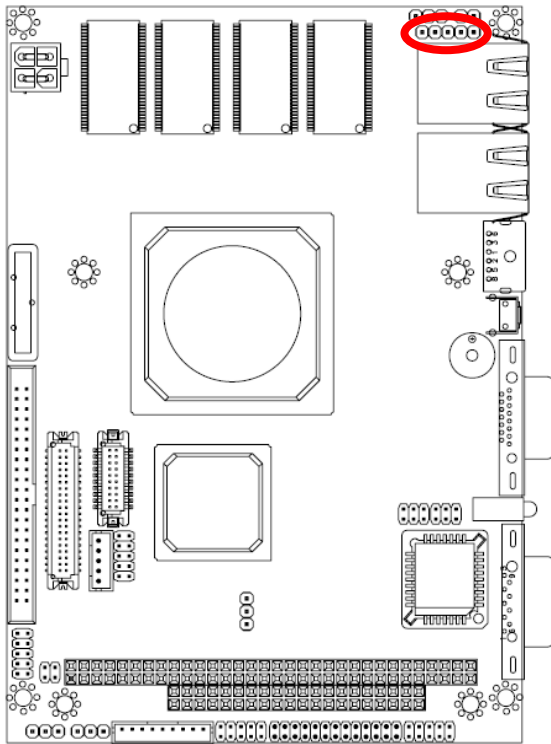

Signal	PIN
+5V	1
NC	2
IRRX	3
GND	4
IRTX	5

ECM-LX800D

2.4.13 USB Connector 0 & 1 (JUSB)

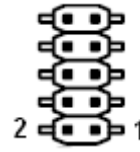
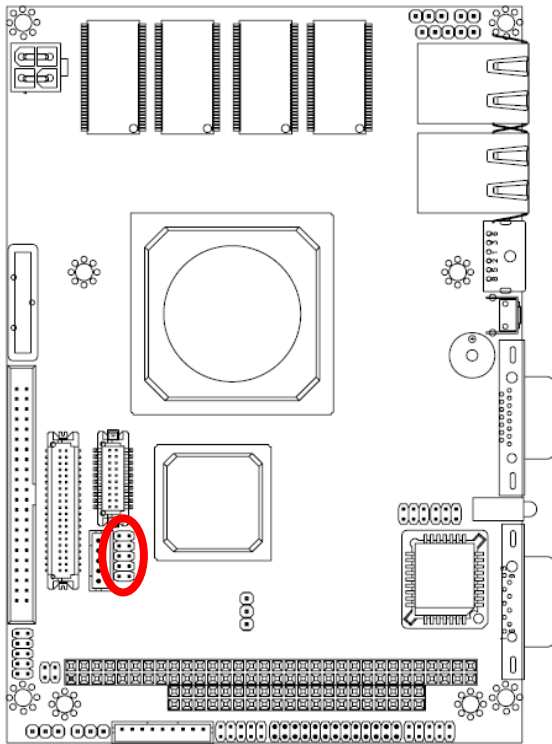

Signal	PIN	PIN	Signal
+5V	10	9	GND
D1-	8	7	GND
D1+	6	5	D0+
GND	4	3	D0-
GND	2	1	+5V

2.4.13.1 Signal Description – USB Connector 0&1 Connector(JUSB)

Signal	Signal Description
D0+/-	Differential bi-directional data signal for USB channel 0 . Clock is transmitted along with the data using NRZI encoding. The signalling bit rate is up to 12 Mbs.
D1+/-	Differential bi-directional data signal for USB channel 1. Clock is transmitted along with the data using NRZI encoding. The signalling bit rate is up to 12 Mbs.

2.4.14 LVDS Connector (JLVDS)

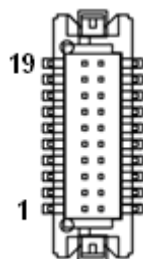
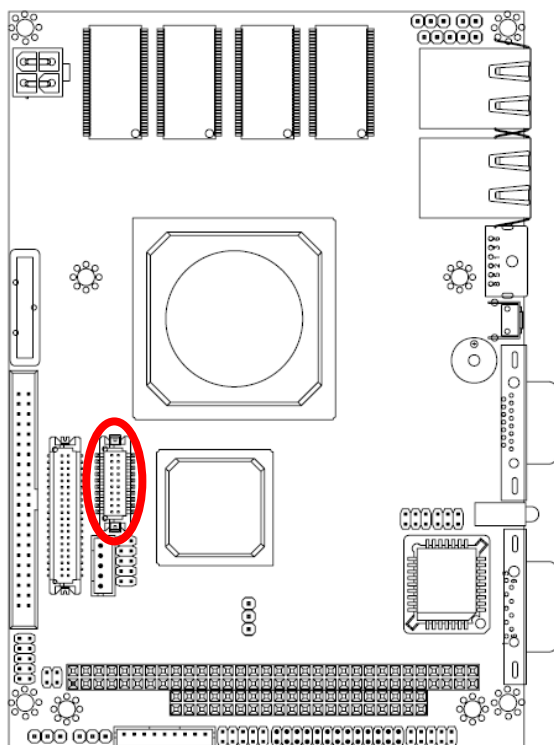

18-bit

Signal	PIN	PIN	Signal
+3.3V	19	20	+5V
+3.3V	17	18	+5V
SMB_DAT	15	16	SMB_CLK
GND	13	14	GND
Txclk	11	12	Txclk#
NC	9	10	NC
Txout2	7	8	Txout2#
Txout1	5	6	Txout1#
Txout0	3	4	Txout0#
GND	1	2	GND

24-bit (Optional)

Signal	PIN	PIN	Signal
+3.3V	19	20	+5V
+3.3V	17	18	+5V
SMB_DAT	15	16	SMB_CLK
GND	13	14	GND
Txclk	11	12	Txclk#
Txout3	9	10	Txout3#
Txout2	7	8	Txout2#
Txout1	5	6	Txout1#
Txout0	3	4	Txout0#
GND	1	2	GND

2.4.14.1 Signal Description – LVDS Connector (JLVDS)

Signal	Description
SMB_DAT, SMB_CLK	SMB interface for panel parameter EEPROM. This EEPROM is mounted on the LVDS receiver. The data in the EEPROM allows the EXT module to automatically set the proper timing parameters for a specific LCD panel.

ECM-LX800D

2.4.15 TFT Panel Connector (JTFT)

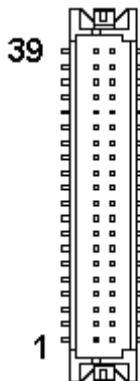
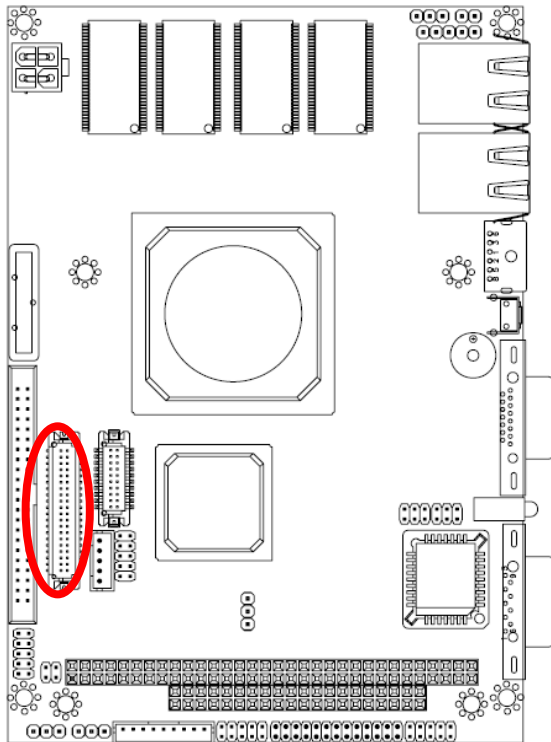

Signal	PIN	PIN	Signal
ENBKL	39	40	NC
LDEM0D	37	38	HSYNC
SHCLK	35	36	VSYNC
GND	33	34	GND
R6	31	32	R7
R4	29	30	R5
R2	27	28	R3
R0	25	26	R1
G6	23	24	G7
G4	21	22	G5
G2	19	20	G3
G0	17	18	G1
B6	15	16	B7
B4	13	14	B5
B2	11	12	B3
B0	9	10	B1
NC	7	8	GND
+3.3V	5	6	+3.3V
GND	3	4	GND
+5V	1	2	+5V

2.4.15.1 Signal Description – TFT Panel Connector (JTFT)

Signal	Description
B [0:6]G[0:6]R[0:6]	Flat panel data output for 24 bit TFT flat panels. The flat panel data and control outputs are all on-board controlled for secure power-on/off sequencing
SHCLK	Shift Clock. Pixel clock for flat panel data
HSYNC	Flat panel equivalent of horizontal synchronization
VSYNC	Flat panel equivalent of vertical synchronization
LDEM0D	Multipurpose signal, function depends on panel type. May be used as AC drive control signal or as BLANK# or Display Enable signal
ENBKL	Enable backlight signal. This signal is controlled as a part of the panel power sequencing

2.4.15.2 Signal Description – TFT Panel Display (JTFT)

PIN	18-bit TFT	24-bit TFT
PIN9	-	B0
PIN10	-	B1
PIN11	B0	B2
PIN12	B1	B3
PIN13	B2	B4
PIN14	B3	B5
PIN15	B4	B6
PIN16	B5	B7
PIN17	-	G0
PIN18	-	G1
PIN19	G0	G2
PIN20	G1	G3
PIN21	G2	G4
PIN22	G3	G5
PIN23	G4	G6
PIN24	G5	G7
PIN25	-	R0
PIN26	-	R1
PIN27	R0	R2
PIN28	R1	R3
PIN29	R2	R4
PIN30	R3	R5
PIN31	R4	R6
PIN32	R5	R7

ECM-LX800D

2.4.16 IDE Connector (IDE)

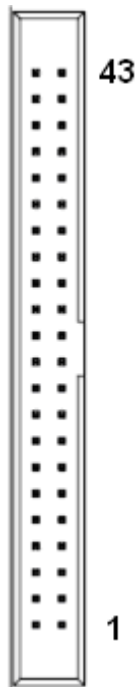
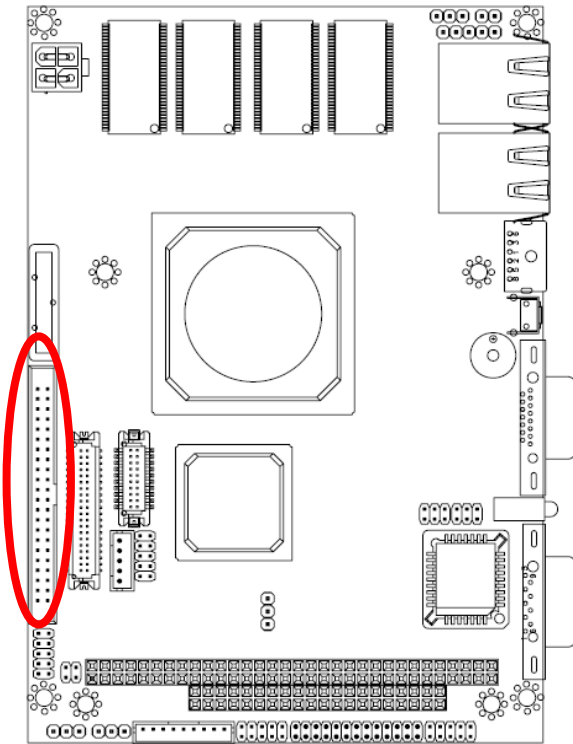

Signal	PIN	PIN	Signal
NC	44	43	GND
+5V	42	41	+5V
GND	40	39	HDLED
IDE_CS1#	38	37	IDE_CS0#
IDE_A2	36	35	IDE_A0
IDE_CABLEID	34	33	IDE_A1
NC	32	31	IDE_IRQ
GND	30	29	IDE_ACK#
IDE_CSEL	28	27	IDE_RDY
GND	26	25	IDE_IOR#
GND	24	23	IDE_IOW#
GND	22	21	IDE_REQ
NC	20	19	GND
IDE_D15	18	17	IDE_D0
IDE_D14	16	15	IDE_D1
IDE_D13	14	13	IDE_D2
IDE_D12	12	11	IDE_D3
IDE_D11	10	9	IDE_D4
IDE_D10	8	7	IDE_D5
IDE_D9	6	5	IDE_D6
IDE_D8	4	3	IDE_D7
GND	2	1	RESET#

2.4.16.1 Signal Description – Primary IDE Connector (IDE)

Signal	Signal Description
IDE_ [2:0]	IDE Address Bits. These address bits are used to access a register or data port in a device on the IDE bus.
PDCS0#, PDCS1#	IDE Chip Selects. The chip select signals are used to select the command block registers in an IDE device. DCS1# selects the primary hard disk.
PDD [15:0]	IDE Data Lines. D [15:0] transfers data to/from the IDE devices.
PDIOR#	IDE I/O Read. Signal is asserted on read accesses to the corresponding IDE port addresses.
PDIOW#	IDE I/O Write. Each signal is asserted on write accesses to corresponding the IDE port addresses.
PIORDY	When deasserted, these signals extend the transfer cycle of any host register access when the device is not ready to respond to the data transfer request.
RESET#	IDE Reset. This signal resets all the devices that are attached to the IDE interface.
IRQ	Interrupt line from hard disk. Connected directly to PC-AT bus.
PDREQ	The DREQ is used to request a DMA transfer from the South Bridge. The direction of the transfers is determined by the IOR#/IOW# signals.
PDDACK#	DMA Acknowledge. The DACK# acknowledges the DREQ request to initiate DMA transfers.
HD_LED1	Signal from hard disk indicating hard disk activity. The signal level depends on the hard disk type, normally active low. The signal is routed directly to the LED.

ECM-LX800D

2.4.17 PS/2 keyboard & mouse connector(KB/MS)

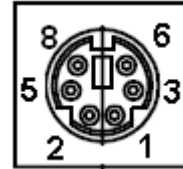
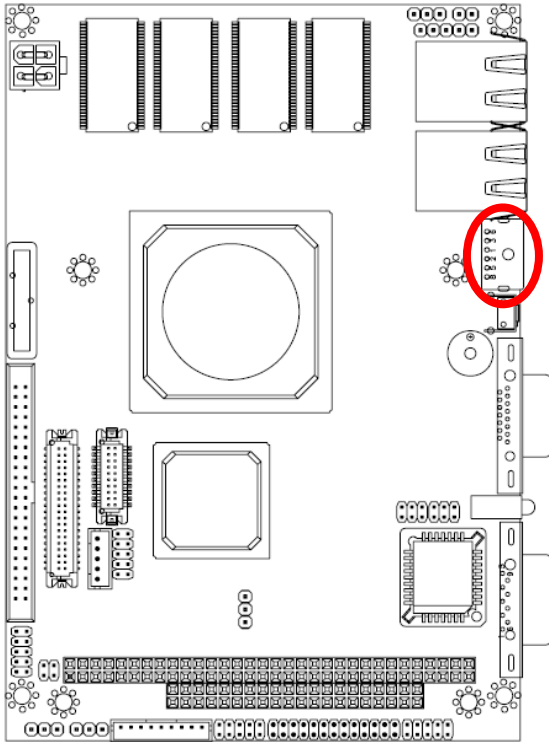

Signal	PIN	PIN	Signal
MCLK	8	6	KCLK
+5V	5	3	GND
MDAT	2	1	KDAT

2.4.18 VGA Connector (JVGA1)

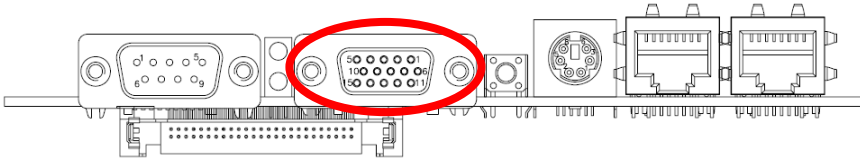

Signal	PIN	Signal
	6	GND
RED	1	11 NC
	7	GND
GREEN	2	12 DAT
	8	GND
BLUE	3	13 HSYNC
	9	VCC
NC	4	14 VSYNC
	10	GND
GND	5	15 DCK

2.4.17.1 Signal Description – VGA Connector (JVGA1)

Signal	Signal Description
HSYNC	CRT horizontal synchronisation output.
VSYNC	CRT vertical synchronisation output.
DCK	Display Data Channel Clock. Used as clock signal to/from monitors with DDC interface.

DAT	Display Data Channel Data. Used as data signal to/from monitors with DDC interface.
RED	Analog output carrying the red colour signal to the CRT. For 75 Ω cable impedance.
GREEN	Analog output carrying the green colour signal to the CRT. For 75 Ω cable impedance.
BLUE	Analog output carrying the blue colour signal to the CRT. For 75 Ω cable impedance.

3. BIOS Setup

3.1 Starting Setup

The AwardBIOS™ is immediately activated when you first power on the computer. The BIOS reads the system information contained in the CMOS and begins the process of checking out the system and configuring it. When it finishes, the BIOS will seek an operating system on one of the disks and then launch and turn control over to the operating system.

While the BIOS is in control, the Setup program can be activated in one of two ways:

By pressing immediately after switching the system on, or

By pressing the key when the following message appears briefly at the bottom of the screen during the POST (Power On Self Test).

Press DEL to enter SETUP

If the message disappears before you respond and you still wish to enter Setup, restart the system to try again by turning it OFF then ON or pressing the "RESET" button on the system case. You may also restart by simultaneously pressing <Ctrl>, <Alt>, and <Delete> keys. If you do not press the keys at the correct time and the system does not boot, an error message will be displayed and you will again be asked to.

Press F1 to Continue, DEL to enter SETUP

3.2 Using Setup

In general, you use the arrow keys to highlight items, press <Enter> to select, use the PageUp and PageDown keys to change entries, press <F1> for help and press <Esc> to quit. The following table provides more detail about how to navigate in the Setup program using the keyboard.

Button	Description
↑	Move to previous item
↓	Move to next item
←	Move to the item in the left hand
→	Move to the item in the right hand
Esc key	Main Menu -- Quit and not save changes into CMOS Status Page Setup Menu and Option Page Setup Menu -- Exit current page and return to Main Menu
PgUp key	Increase the numeric value or make changes
PgDn key	Decrease the numeric value or make changes
+ key	Increase the numeric value or make changes
- key	Decrease the numeric value or make changes
F1 key	General help, only for Status Page Setup Menu and Option Page Setup Menu
(Shift) F2 key	Change color from total 16 colors. F2 to select color forward, (Shift) F2 to select color backward
F3 key	Calendar, only for Status Page Setup Menu
F4 key	Reserved
F5 key	Restore the previous CMOS value from CMOS, only for Option Page Setup Menu
F6 key	Load the default CMOS value from BIOS default table, only for Option Page Setup Menu
F7 key	Load the default
F8 key	Reserved
F9 key	Reserved
F10 key	Save all the CMOS changes, only for Main Menu

- **Navigating Through The Menu Bar**

Use the left and right arrow keys to choose the menu you want to be in.



Note: Some of the navigation keys differ from one screen to another.

- **To Display a Sub Menu**

Use the arrow keys to move the cursor to the sub menu you want. Then press <Enter>. A “>” pointer marks all sub menus.

3.3 Getting Help

Press F1 to pop up a small help window that describes the appropriate keys to use and the possible selections for the highlighted item. To exit the Help Window press <Esc> or the F1 key again.

3.4 In Case of Problems

If, after making and saving system changes with Setup, you discover that your computer no longer is able to boot, the AwardBIOS™ supports an override to the CMOS settings which resets your system to its defaults.

The best advice is to only alter settings which you thoroughly understand. To this end, we strongly recommend that you avoid making any changes to the chipset defaults. These defaults have been carefully chosen by both Award and your systems manufacturer to provide the absolute maximum performance and reliability. Even a seemingly small change to the chipset setup has the potential for causing you to use the override.

3.5 Main Menu

Once you enter the AwardBIOS™ CMOS Setup Utility, the Main Menu will appear on the screen. The Main Menu allows you to select from several setup functions and two exit choices. Use the arrow keys to select among the items and press <Enter> to accept and enter the sub-menu.

Note that a brief description of each highlighted selection appears at the bottom of the screen.

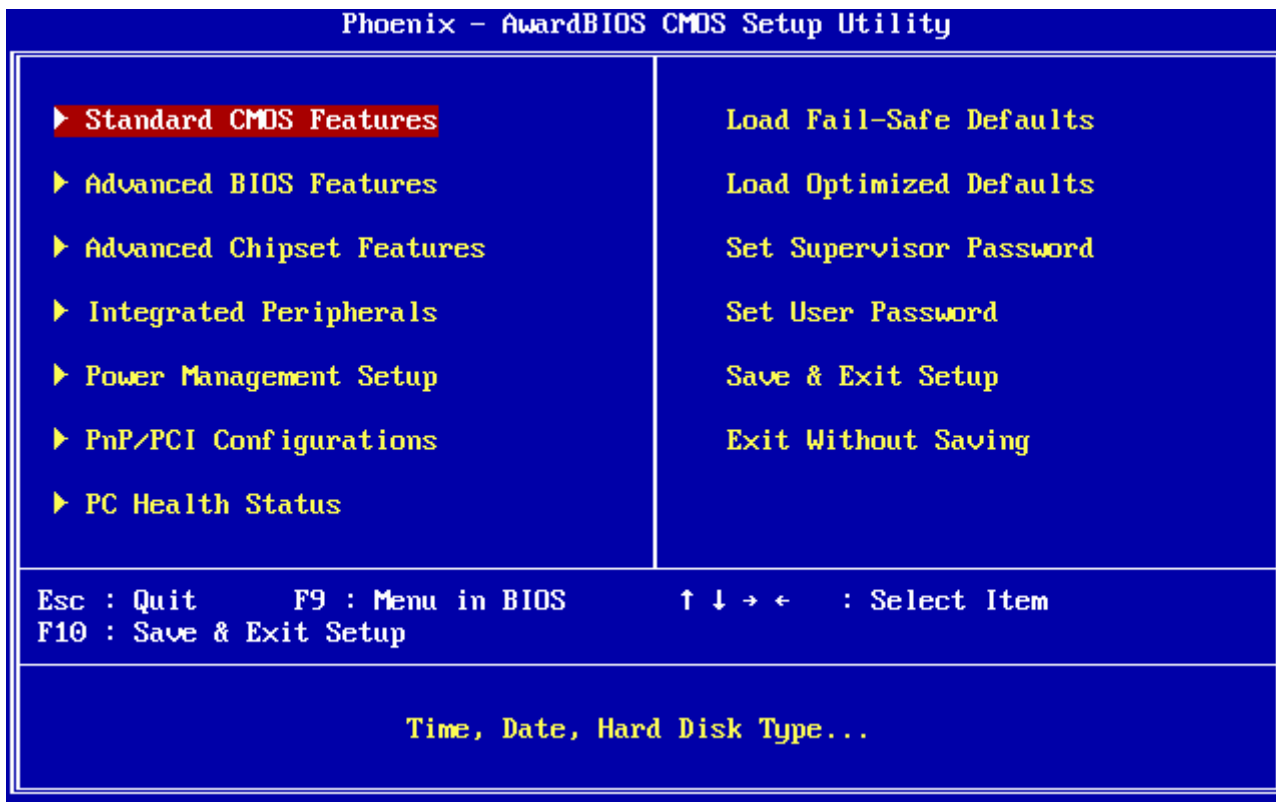

Note: The BIOS setup screens shown in this chapter are for reference purposes only, and may not exactly match what you see on your screen. Visit the Avalue website (www.avalue.com.tw) download the latest product and BIOS information.

3.5.1 Standard CMOS Features

The items in Standard CMOS Setup Menu are divided into few categories. Each category includes no, one or more than one setup items. Use the arrow keys to highlight the item and then use the <PgUp> or <PgDn> keys to select the value you want in each item.

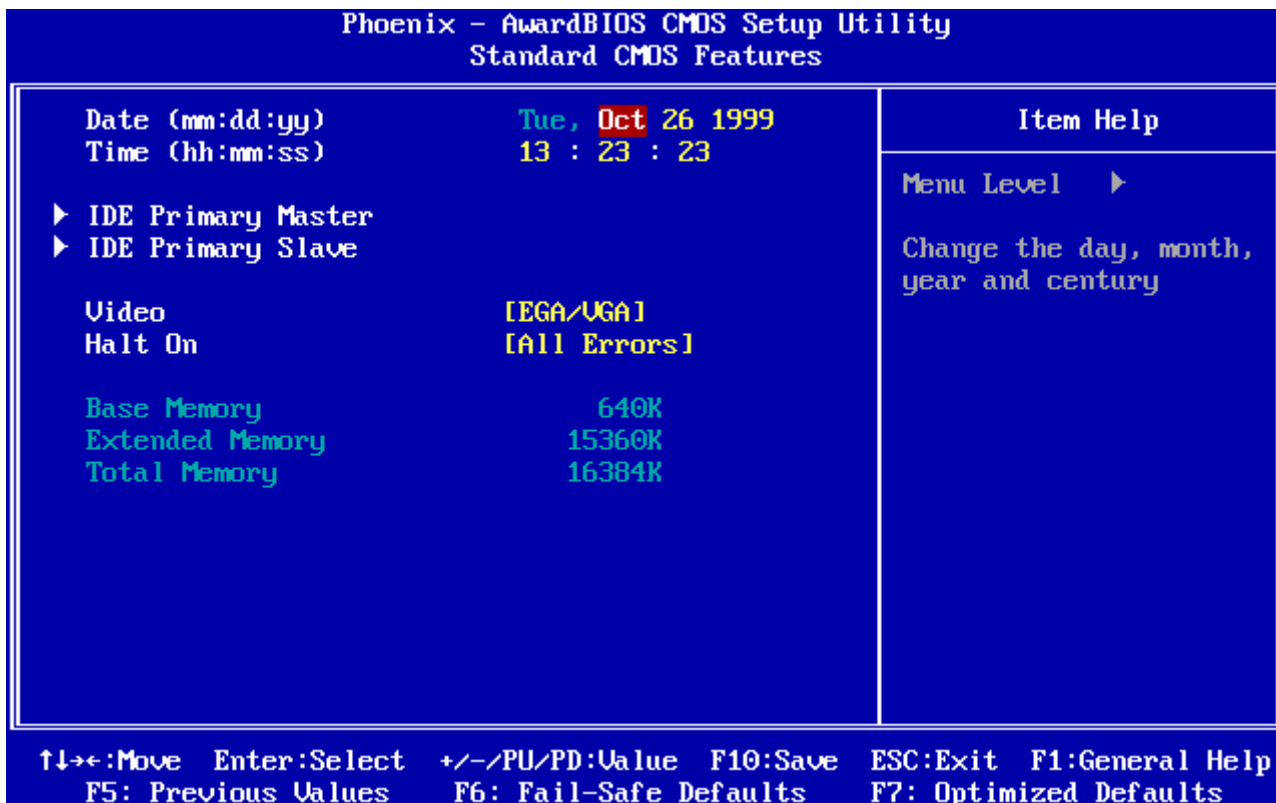

3.5.1.1 Main Menu Selection

This reference table shows the selections that you may make on the Main Menu.

Item	Options	Description
Date	MM DD YYYY	Set the system date. Note that the 'Day' automatically changes when you set the date
Time	HH : MM : SS	Set the system time
IDE Primary Master IDE Primary Slave	Options are in 3.5.1.2	Press <Enter> to enter the sub menu of detailed options
Video	EGA/VGA CGA 40 CGA 80 MONO	Select the default video device
Halt On	All Errors No Errors All, but Keyboard	Select the situation in which you want the BIOS to stop the POST process and notify you

ECM-LX800D

3.5.1.2 IDE Adapter Setup

The IDE adapters control the hard disk drive. Use a separate sub menu to configure each hard disk drive. The below Figure will shows the IDE primary master sub menu.

Item	Options	Description
IDE HDD Auto-detection	Press Enter	Press Enter to auto-detect the HDD on this channel. If detection is successful, it fills the remaining fields on this menu.
IDE Primary Master IDE Primary Slave,	None Auto Manual	Selecting 'manual' lets you set the remaining fields on this screen. Selects the type of fixed disk. "User Type" will let you select the number of cylinders, heads, etc. Note: PRECOMP=65535 means NONE !
Access Mode	CHS LBA Large Auto	Choose the access mode for this hard disk
The following options are selectable only if the 'IDE Channel ...' item is set to 'Manual'		
Cylinder	Min = 0 Max = 65535	Set the number of cylinders for this hard disk.
Head	Min = 0 Max = 255	Set the number of read/write heads
Precomp	Min = 0 Max = 65535	**** Warning: Setting a value of 65535 means no hard disk
Landing zone	Min = 0 Max = 65535	****
Sector	Min = 0 Max = 255	Number of sectors per track

3.5.2 Advanced BIOS Features

This section allows you to configure your system for basic operation. You have the opportunity to select the system's default speed, boot-up sequence, keyboard operation, shadowing and security.

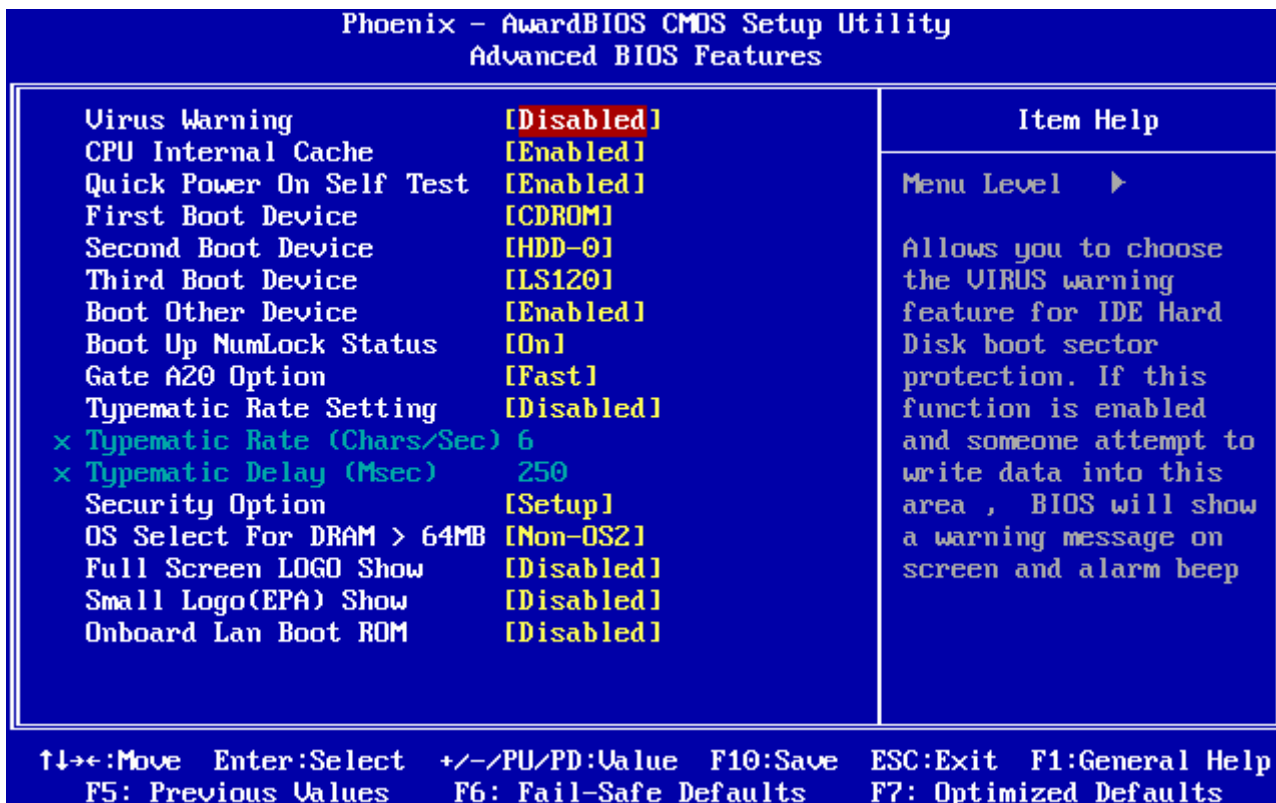

3.5.2.1 Virus Warning

This item allows you to choose the VIRUS Warning feature for IDE Hard Disk boot sector protection. If this function is enabled and someone attempt to write data into this area, BIOS will show a warning message on screen and alarm beep.

Item	Description
Enabled	Activates automatically when the system boots up causing a warning message to appear when anything attempts to access the boot sector or hard disk partition table.
Disabled	No warning message will appear when anything attempts to access the boot sector or hard disk partition table.

3.5.2.2 CPU Internal Cache

This category speeds up memory access. However, it depends on CPU/chipset design. The default value is enable.

Item	Description
Enabled	Enable cache
Disabled	Disable cache

3.5.2.3 Quick Power On Self Test

This category speeds up Power On Self Test (POST) after you power up the computer. If it is set to Enable, BIOS will shorten or skip some check items during POST.

Item	Description
Enabled	Enable quick POST
Disabled	Normal POST

ECM-LX800D

3.5.2.4 First/Second/Third/Other Boot Device

The BIOS attempts to load the operating system from the devices in the sequence selected in these items.

Item	Description
LS120	LS120 Device
HDD-0	Hard Disk Device 0
SCSI	SCSI Device
CDROM	CDROM Device
HDD-1	Hard Disk Device 1
USB-FDD	USB Floppy Device
USB-ZIP	USB ZIP Device
USB-CDROM	USB CDROM Device
USB-HDD	USB Hard Disk Device
LAN	Network Device
Disabled	Disabled any boot device

3.5.2.5 Boot Up NumLock Status

Select power on state for NumLock.

Item	Description
Enabled	Enable NumLock
Disabled	Disable NumLock

3.5.2.6 Gate A20 Option

Select if chipset or keyboard controller should control Gate A20.

Item	Description
Normal	A pin in the keyboard controller controls Gate A20
Fast	Lets chipset control Gate A20

3.5.2.7 Typematic Rate Setting

Key strokes repeat at a rate determined by the keyboard controller. When enabled, the typematic rate and typematic delay can be selected.

Item	Description
Enabled	Enable typematic rate/delay setting
Disabled	Disable typematic rate/delay setting

3.5.2.8 Typematic Rate (Chars/Sec)

Select "Enabled" of Typematic Rate then set the rate at which a character keeps repeating while holding down a key.

The choices: 6,8,10,12,15,20,24,30

3.5.2.9 Typematic Delay (Msec)

Select "Enabled" of Typematic Rate then set the length of delay before keying strokes to repeat.

The choices: 250, 500, 750, 1000

3.5.2.10 Security Option

To allow selecting whether the password is required every time the system boots or only when you enter the Setup.

Item	Description
Setup	Require password when entering the main CMOS Setup Utility Screen only.
System	Require password every time the system boots



Note: To disable security, select PASSWORD SETTING at Main Menu and then you will be asked to enter password. Do not type anything and just press <Enter>, it will disable security. Once the security is disabled, the system will boot and you can enter Setup freely.

3.5.2.11 OS Select for DRAM > 64MB

Select the operating system that is running with greater than 64MB of RAM on the system.

Item	Description
Non-OS2	Disable OS for over 64 MB DRAM
OS2	Enable OS for over 64 MB DRAM

3.5.2.12 Full Screen LOGO Show

If the BIOS had the full screen logo in it, this item could allow enable/ disable the full screen logo show on display.

Item	Description
Enable	Enable full screen logo show
Disable	Disable full screen logo show

3.5.2.13 Small Logo (EPA) Show

This item allows you enabled/disabled the small EPA logo show on screen at the POST step.

Item	Description
Enabled	EPA Logo show is enabled
Disabled	EPA Logo show is disabled

3.5.2.14 Onboard Lan Boot ROM

This item allows to boot over the network when system POST and shorten the booting time by set disabled

Item	Description
Enabled	Enable Onboard LAN boot.
Disabled	Disabled Onboard LAN boot.

ECM-LX800D

3.5.3 Advanced Chipset Features

This section allows you to configure the system based on the specific features of the installed chipset. This chipset manages bus speeds and access to system memory resources, such as DRAM and the external cache. It also coordinates communications between the conventional ISA bus and the PCI bus. It must be stated that these items should never need to be altered. The default settings have been chosen because they provide the best operating conditions for your system. The only time you might consider making any changes would be if you discovered that data was being lost while using your system.

The first chipset settings deal with CPU access to dynamic random access memory (DRAM). The default timings have been carefully chosen and should only be altered if data is being lost. Such a scenario might well occur if your system had mixed speed DRAM chips installed so that greater delays may be required to preserve the integrity of the data held in the slower memory chips.

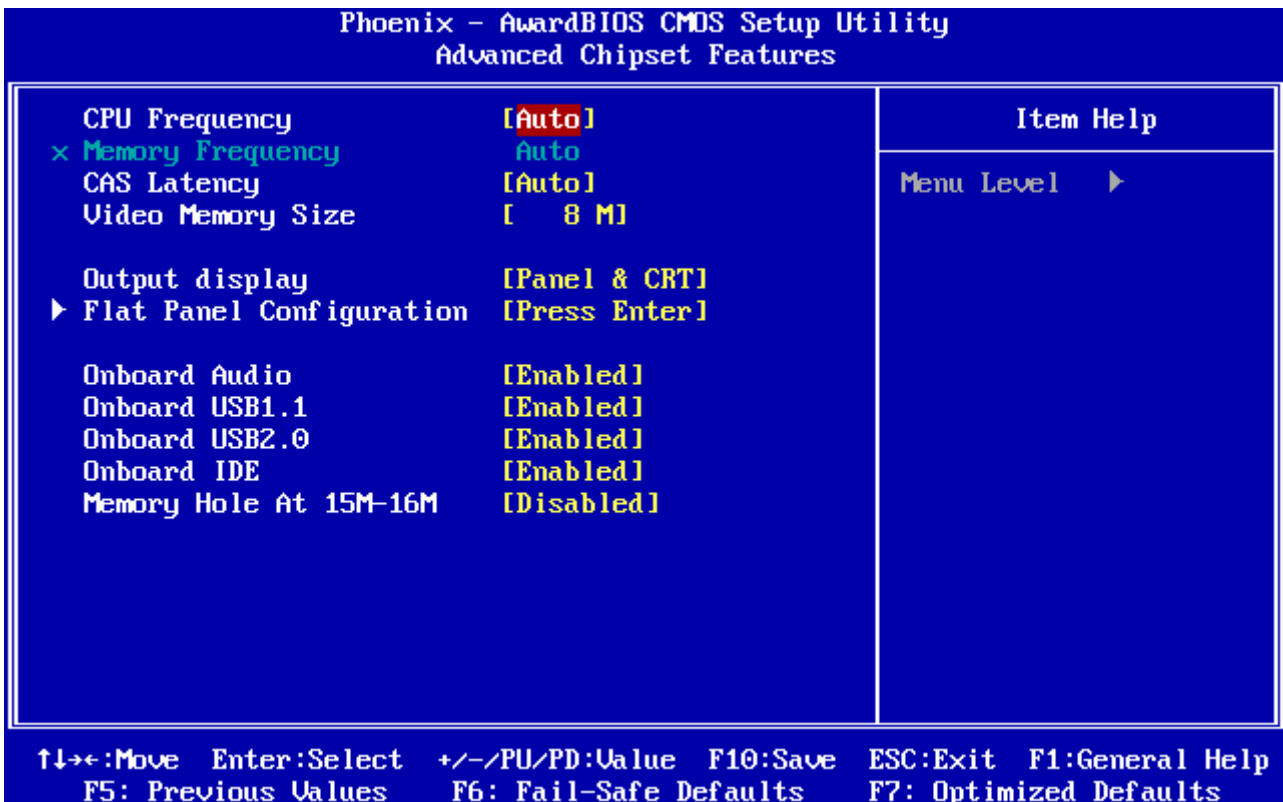

3.5.3.1 CPU Frequency

This item allows to select CPU frequency.

The choices: Auto, 200, 333, 400, 433, 500,600

3.5.3.2 Memory Frequency

This item allows to select Memory frequency.

The choices: Auto, 100, 133, 166, 200

3.5.3.3 CAS Latency

It's the time, in number of clock cycles, elapses after the memory controller sends a request to read a memory location and before the data is sent to the module's output pins.

The choices: Auto, 1.5, 2.0, 2.5, 3.0, 3.5

3.5.3.4 Video Memory Size

This item allows to select video memory size.

The choices: Disable, 8 M, 16 M, 32 M, 64 M, 128 M, 254 M.

3.5.3.5 Output Display

This item allows to select video memory size.

The choices: Flat Panel, CRT Monitor, Panel & CRT.

3.5.3.6 Flat Panel Configuration

Item	Options	Description
Resolution	320x240, 640x480, 800x600, 1024x768, 1152x864, 1280x1024, 1600x1200	This item allows to select the resolution.
Refresh Rate	60Hz, 70Hz, 72Hz, 75Hz, 85Hz, 90Hz, 100Hz	This refresh rate is only the number of time the image is being refreshed on the monitor screen.
HSYNC Polarity	Normal High, Normal Low	Select polarity of HSYNC signals.
VSYNC Polarity Active	Normal High, Normal Low	Set the polarity of VSYNC signals active.
SHFCLK Active Period	Active only, Free running	Shift clock or pixel clock for the flat panel data.
LP Active Period	Free running, Active running	Latch Pulse is the line pulse or latch pulse for the flat panel data.

3.5.3.7 Onboard Audio

This item allows you to enable the onboard audio function.

ECM-LX800D

The choices: Enabled, Disabled.

3.5.3.8 Onboard USB1.1

This item allows you to enable the onboard USB1.1 function.

The choices: Enabled, Disabled.

3.5.3.9 Onboard USB2.0

This item allows you to enable the onboard USB2.0 function.

The choices: Enabled, Disabled.

3.5.3.10 Onboard IDE

This item allows you to enable the onboard IDE function.

The choices: Enabled, Disabled.

3.5.3.11 Memory Hole At 15M-16M

This item allows you to reserve the memory area for some specific ISA card's use.

The choices: Enabled, Disabled.

3.5.4 Integrated Peripherals

Use this menu to specify your settings for integrated peripherals.

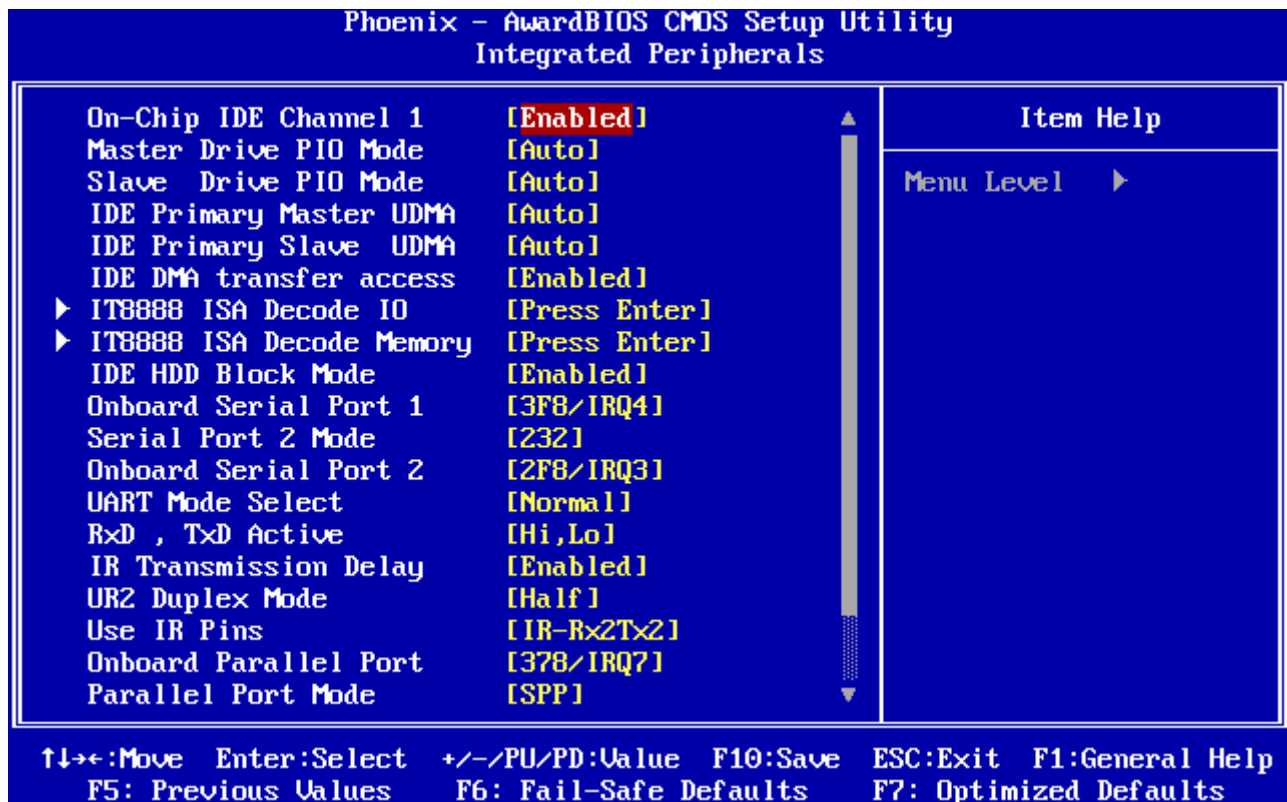

Item	Options	Description
On-Chip IDE Channel 1	Enabled Disabled	This item allows to enable On-chip IDE channel.
Master Drive PIO Mode Slave Drive PIO Mode	Auto Mode 0 Mode 1 Mode 2 Mode 3 Mode 4	The IDE PIO (Programmed Input/Output) fields let you set a PIO mode (0-4) for each of the four IDE devices that the onboard IDE interface supports. Modes 0 through 4 provide successively increased performance. In Auto mode, the system automatically determines the best mode for each device.

IDE Primary Master UDMA IDE Primary Slave UDMA	Auto Disabled	Ultra DMA implementation is possible only if your IDE hard drive supports it and the operating environment includes a DMA driver (Windows 95 OSR2 or a third-party IDE bus master driver). If the hard drive and the system software both support Ultra DMA, select Auto to enable BIOS support.
IDE DMA Transfer Access	Enabled Disabled	This item allows to enable or disable DMA (Direct Memory Access) support for all IDE devices.
IDE HDD Block Mode	Enabled Disabled	Block mode is also called block transfer, multiple commands, or multiple section read/write. If the IDE hard drive supports block mode (most new drives do), select Enabled for automatic detection of the optimal number of block read/writes per sector the drive can support.
Onboard Serial Port 1 Onboard Serial Port 2	Disable 3F8/IRQ4 2F8/IRQ3 3E8/IRQ4 2E8/IRQ3 Auto	Select an address and corresponding interrupt for the first serial ports.
Serial Port 2 Mode	232 422 485	Select the mode of serial port 2.
UART Mode Select	IrDA ASKIR Normal	Select UART2 mode as standard serial port or IR port.
RxD , TxD Active	Hi,Hi Hi,Lo Lo,Hi Lo,Lo	This item allows you to determine the active of RxD, TxD level.
IR Transmission Delay	Enabled Disabled	This item allows you to enable/disable the IR Transmission Delay.
UR2 Duplex Mode	Half Full	Select the value required by the IR device connected to the IR port. Full-duplex mode permits simultaneous two-direction transmission. Half-duplex mode permits transmission in one direction only at a time.
Use IR Pins	RxD2,TxD2 IR-Rx2Tx2	This item allows you to determine the pin definition.
Onboard Parallel Port	Disabled 378/IRQ7 278/IRQ5 3BC/IRQ7 FDD Mode	Select a matching address and interrupt for the physical parallel (printer) port.
Parallel Port Mode	SPP EPP ECP ECP+EPP Normal	Select an operating mode for the onboard parallel port. Select Compatible or Extended unless you are certain both your hardware and software support EPP or ECP mode.
EPP Mode Select	EPP1.9 EPP1.7	Select EPP port type 1.7 or 1.9.
ECP Mode Use DMA	1, 3	Select a DMA channel for the port.
Watch Dog Timer Select	Disabled, 10, 20, 30, 40 Sec. 1, 2, 4 Min.	This option will determine watch dog timer

ECM-LX800D

3.5.4.1 IT8888 ISA Decode IO

The decode I/O spaces can be programmed to claim PCI I/O cycle with Fast/Medium/Slow/Subtractive DEVSEL# (Device Select) timing speed.

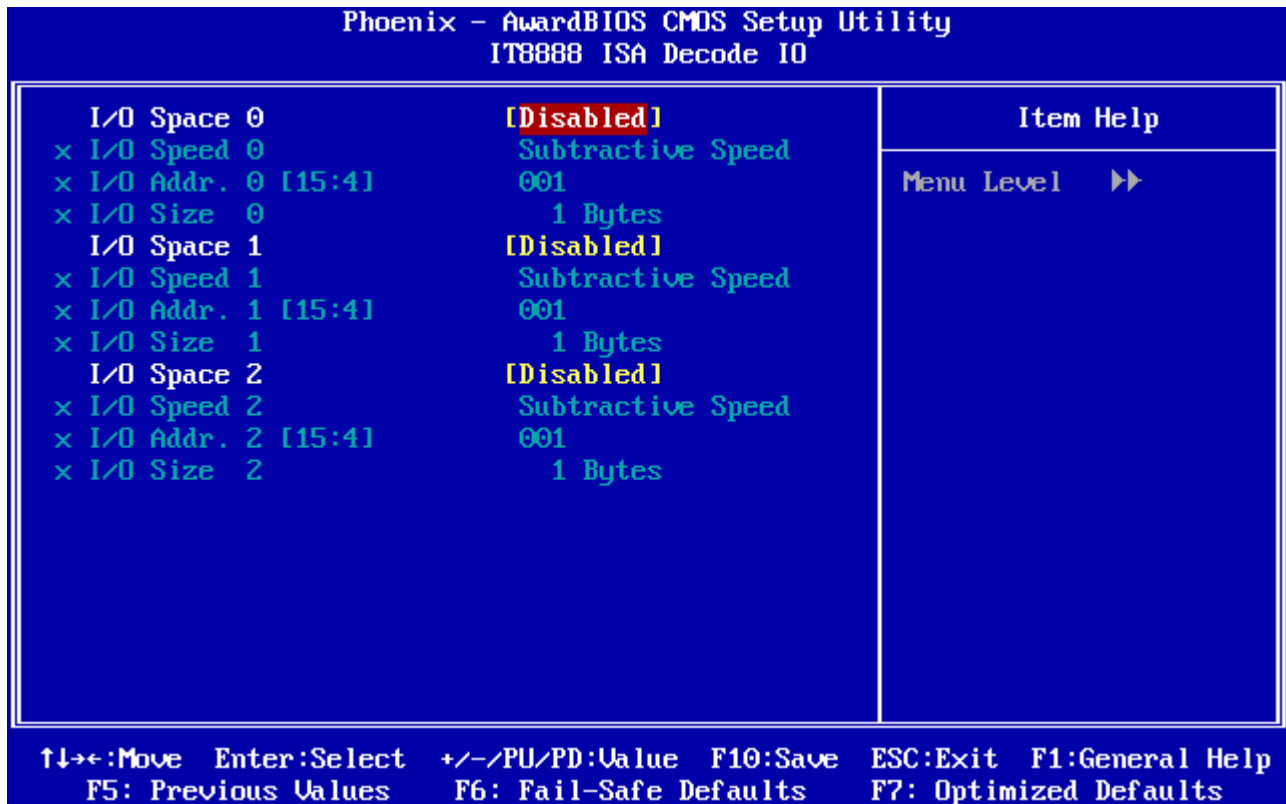

Item	Options	Description
I/O Space 0 I/O Space 1 I/O Space 2	Enabled Disabled	It allows you to allocate system resources to the ISA bridge and to enable
I/O Speed 0 I/O Speed1 I/O Speed2	Subtractive Speed Slow Speed Medium Speed Fast Speed	It allows you to specify the speed of the ISA bus.
I/O Addr. 0 I/O Addr. 1 I/O Addr. 2	1~4095	It allows you to allocate an address to the ISA bus.
I/O Size	1,2,4,8,16,32,64,128 bytes	It allows you to specify the size of the ISA bus.

3.5.4.2 IT8888 ISA Decode Memory

The decode Memory spaces can be programmed to claim PCI Memory cycle with Fast/Medium/Slow/Subtractive DEVSEL# (Device Select) timing speed.

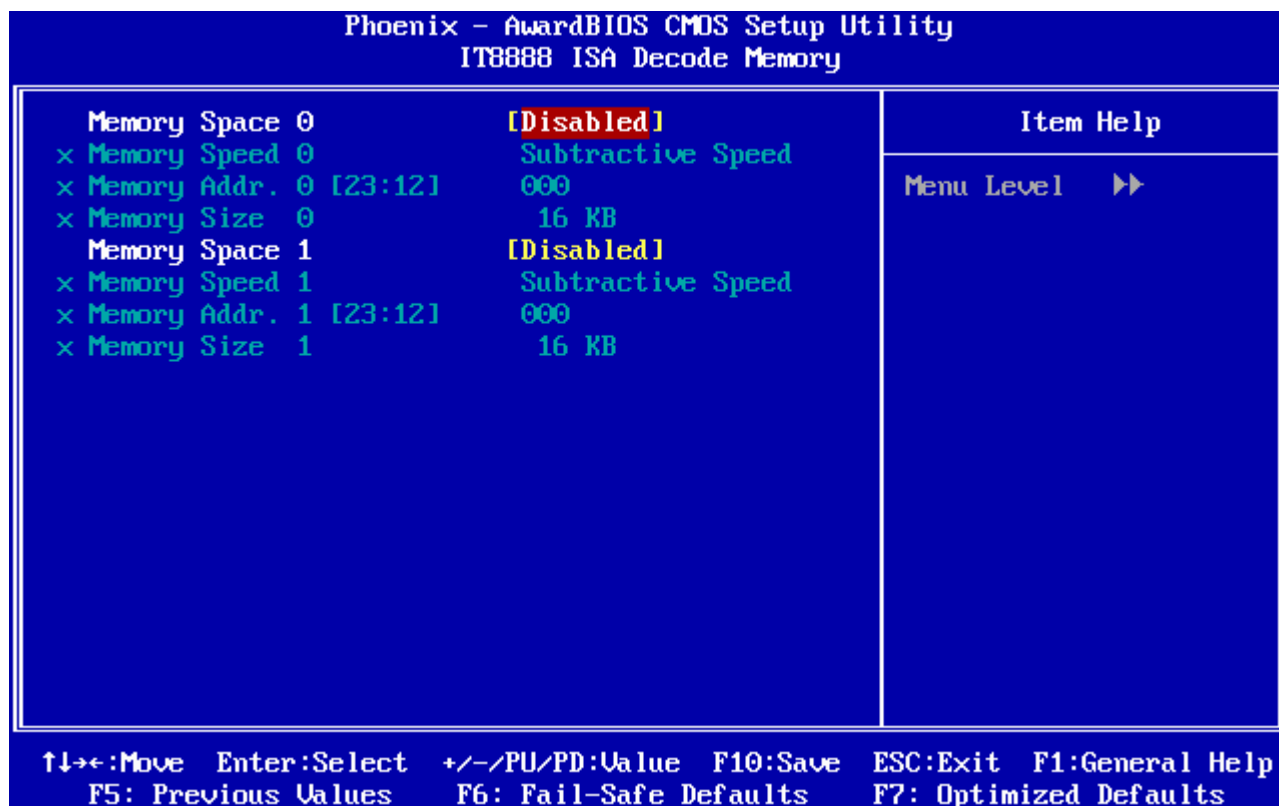

It allows you to use the IT8888 ISA Decode Memory to set the resources for the onboard ISA bus.

Item	Options	Description
Memory Space 0 Memory Space 1	Enabled Disabled	It allows you to allocate memory resources to the ISA bridge and to enable the function correctly.
Memory Speed 0 Memory Speed 1	Subtractive Speed Slow Speed Medium Speed Fast Speed	It allows you to specify the memory speed of the ISA bus.
Memory Addr. 0 Memory Addr. 1	0~4095	It allows you to allocate a memory address to the ISA bus.
Memory Size 0 Memory Size 1	16,32,64,128,256,512KB, 1MB,2MB	It allows you to specify the memory size of the ISA bus.

3.5.5.2 Power Management Setup

The Power Management Setup allows you to configure you system to most effectively save energy while operating in a manner consistent with your own style of computer use.

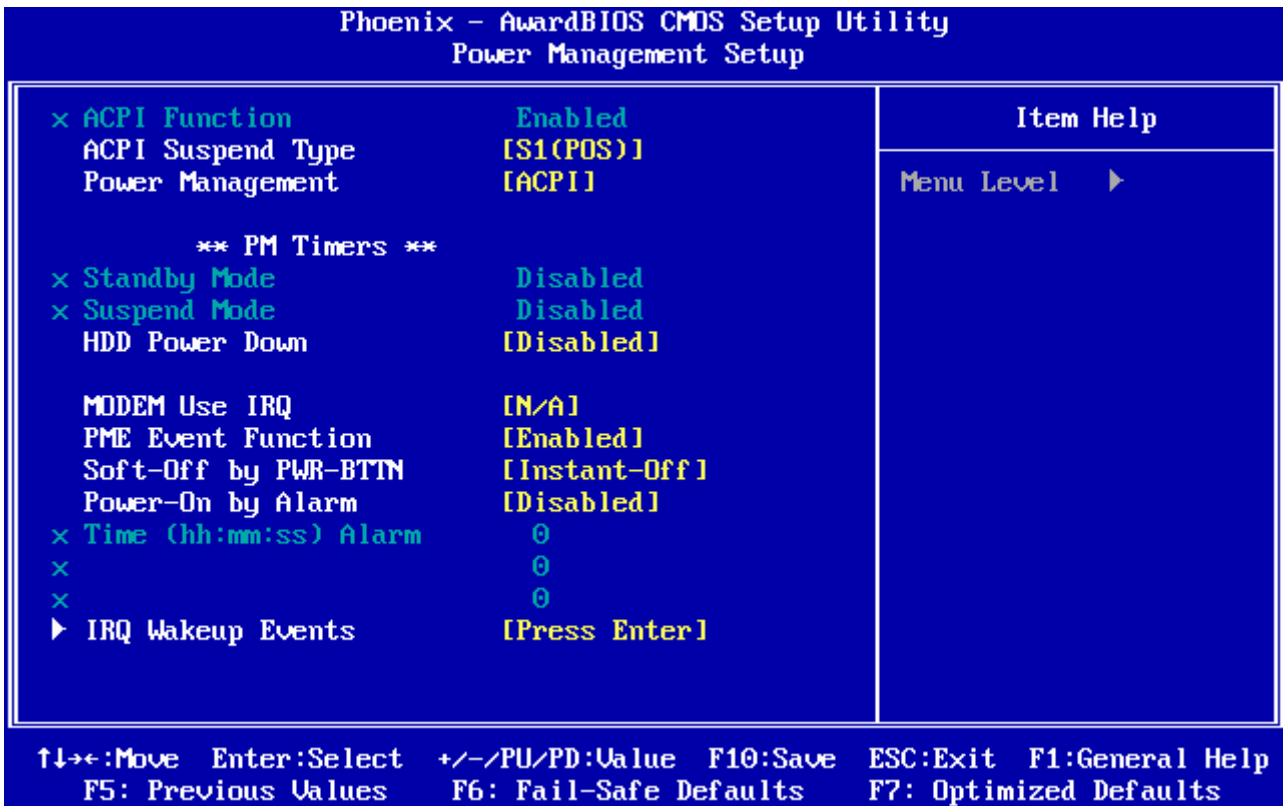

3.5.7.1 ACPI Suspend Type

This determines the ACPI suspend type.

The choices: S1(POS), S3(STR)

3.5.7.2 Power Management

This category allows you to select the type (or degree) of power saving.

The choices: Disabled, Legacy, APM, ACPI

3.5.7.3 HDD Power Down

This item controls how long a hard disk must be left idle before it spins down.

The choices: Disabled, 1,5,10,15,30,45 Sec., 1,5,10,15,30,45,60,90,120 Min.

3.5.7.4 MODEM Use IRQ

This determines the IRQ in which the MODEM can use.

The choices: N/A, 3, 4, 5, 7, 9, 10, 11.

3.5.7.5 PME Event Function

This determines whether to enable the PME Event wake up function or not.

The choices: Disabled, Enabled.

3.5.7.6 Soft-Off by PWR-BTTN

This determines to use power saving mode or not. When set to Delay 4 Sec, this function allows the power button to put the system in suspend, a power saving mode; otherwise, the computer turns completely off when the power button is pressed by setting as Instant-Off.

The choices: Instant-Off, Delay 4 Sec.

3.5.7.7 Power On By Alarm

This determines whether to set the time the system boot up. When this function is enabled, you need to set the time (hh:mm:ss) to wake up your system.

The choices: Disabled, Enabled.

3.5.7.8 IRQ Wakeup Events

The VGA, LPT & COM, HDD & FDD, and PCI master are I/O events which can prevent the system from entering a power saving mode or can awaken the system from such a mode. When an I/O device wants to gain the attention of the operating system, it signals this by causing an IRQ to occur. When the operating system is ready to respond to the request, it interrupts itself and performs the service.

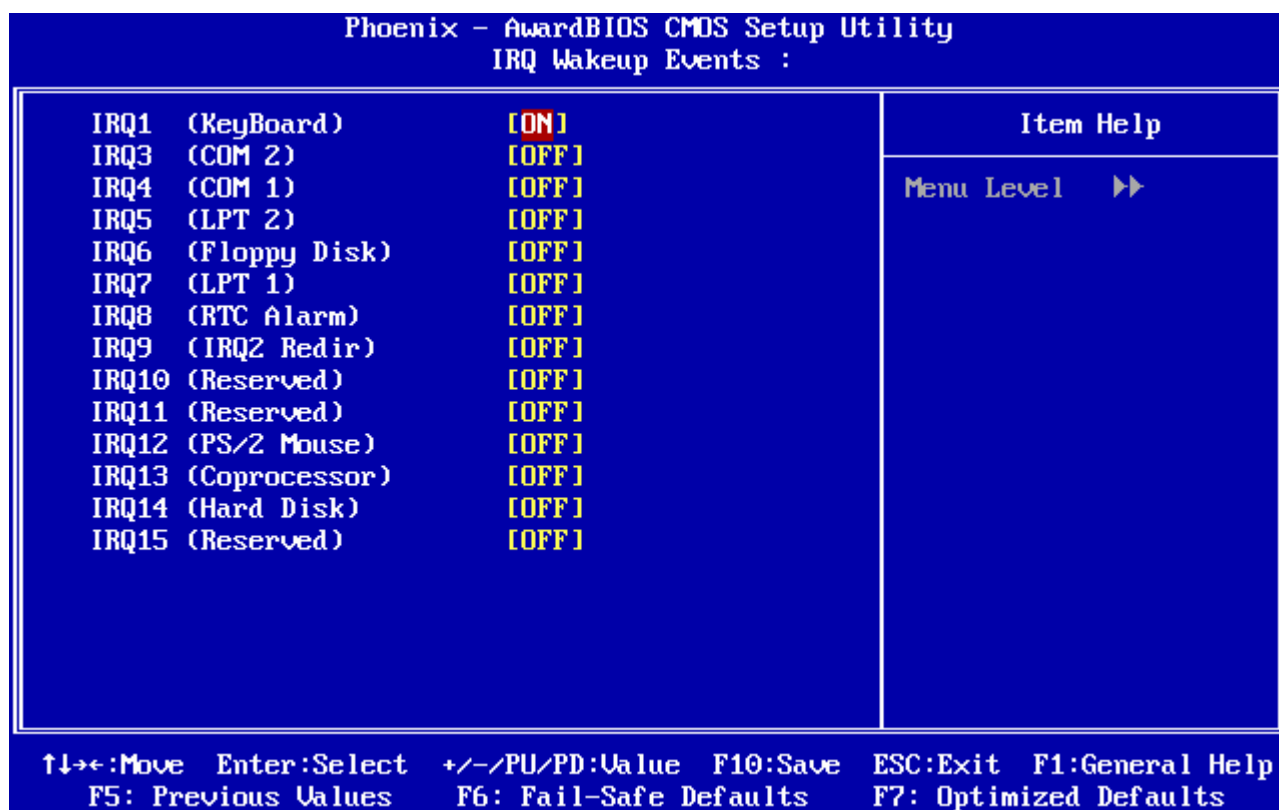

3.5.6.2 PnP / PCI Configuration

This section describes configuring the PCI bus system. PCI, or **Personal Computer Interconnect**, is a system which allows I/O devices to operate at speeds nearing the speed the CPU itself uses when communicating with its own special components. This section covers some very technical items and it is strongly recommended that only experienced users should make any changes to the default settings.

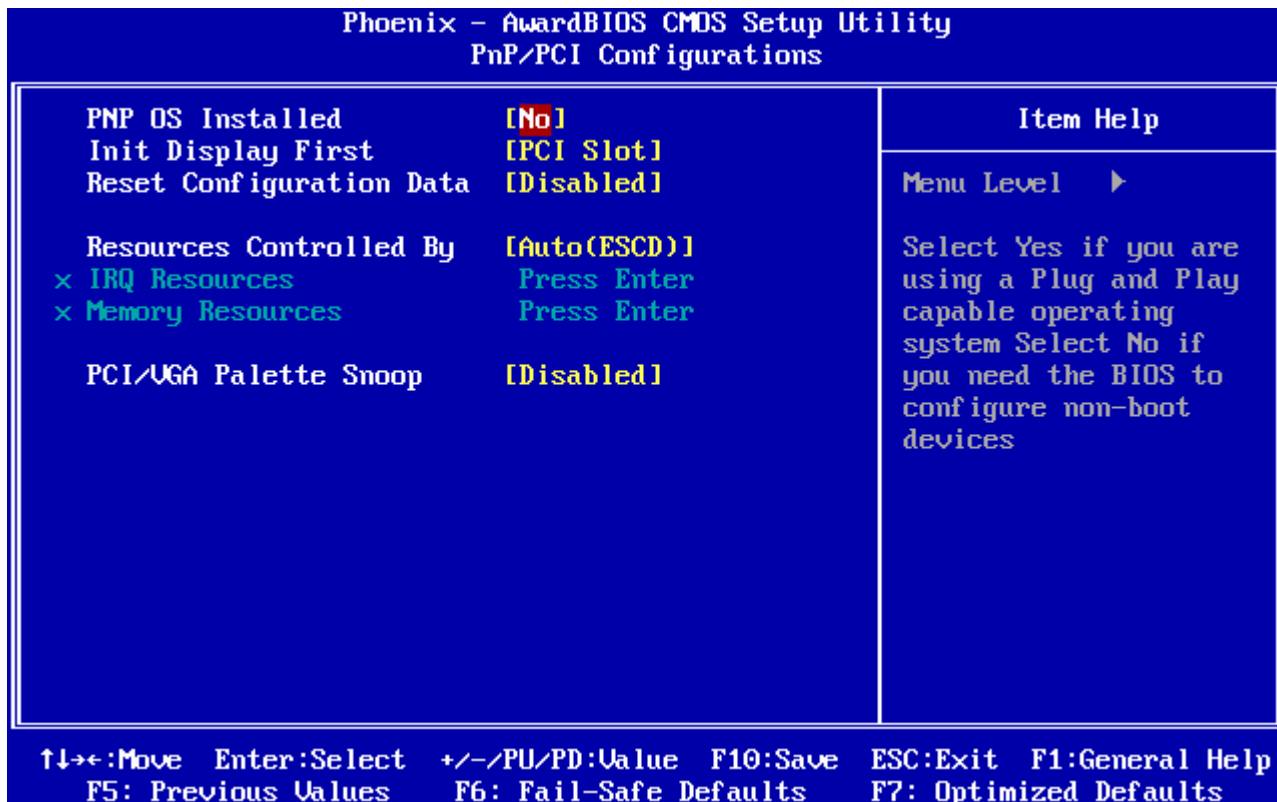

3.5.8.1 PNP OS Installed

The operation system environment is Plug-and-Play aware sets “YES”

The choices: No, Yes.

3.5.8.2 Init Display First

This item allows you to decide to active whether PCI Slot or AGP first.

The choices: PCI Slot, Onboard.

3.5.8.3 Reset Configuration Data

Normally, you leave this field Disabled. Select Enabled to reset Extended System Configuration Data (ESCD) when you exit Setup if you have installed a new add-on and the system reconfiguration has caused such a serious conflict that the operating system cannot boot.

The choices: Disabled, Enabled.

3.5.8.4 Resources Controlled By

The Award Plug and Play BIOS has the capacity to automatically configure all of the boot and Plug and Play compatible devices. However, this capability means absolutely nothing unless you are using a Plug and Play operating system such as Windows®95. If you set

this field to “manual” choose specific resources by going into each of the sub menu that follows this field (a sub menu is preceded by a “>”).

The choices: Auto(ESCD), Manual.

3.5.8.5 PCI/VGA Palette Snoop

This item allows you to decide if your graphics card should allow VGA palette snooping by a fixed function display card. It is only useful if you use a fixed function display card that requires a VGA-compatible graphics card to be present (i.e. MPEG decoder card).

The choices: Enabled, Disabled.

3.5.7.2 PC Health Status

This section shows the status of your CPU, Fan & System.

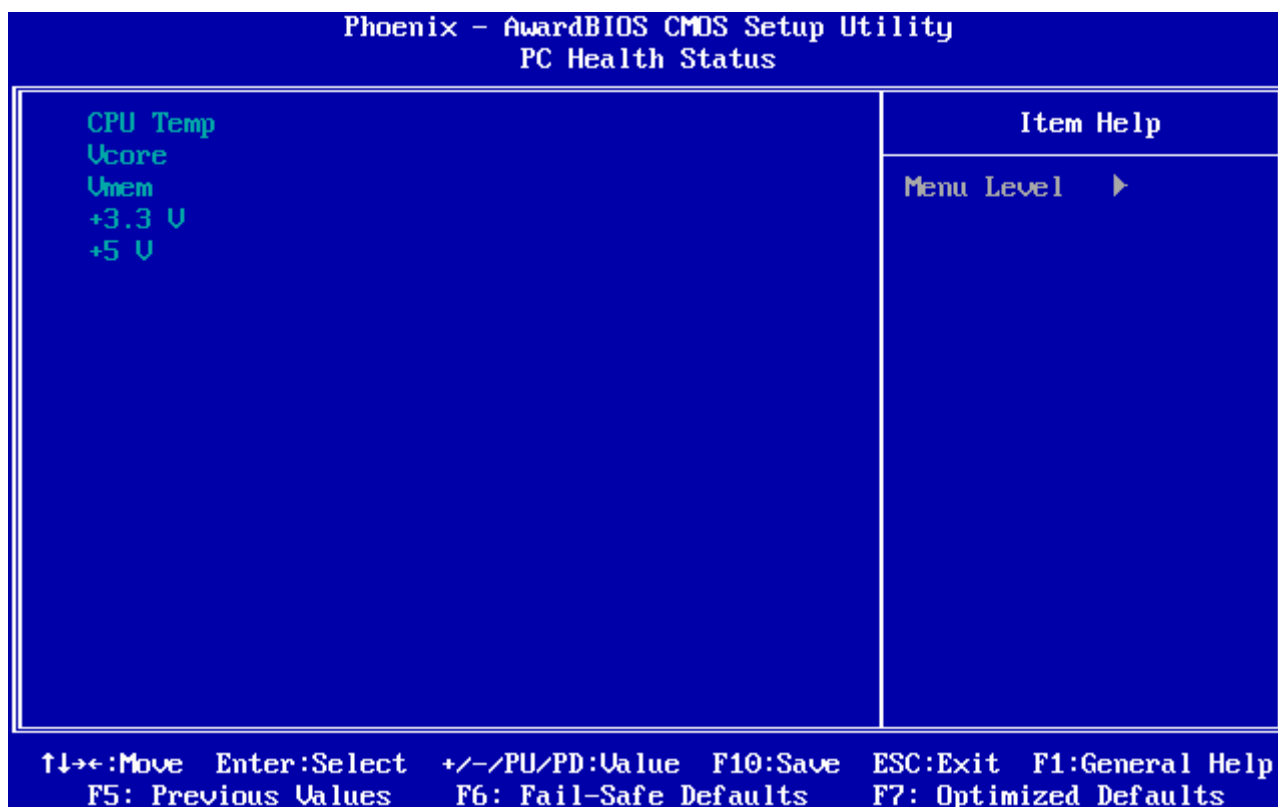

3.5.8.2 Load Fail-Safe Defaults

Use this menu to load the BIOS default values for the minimal/stable performance for your system to operate. Press <Y> to load the BIOS default values for the most stable, minimal-performance system operations.

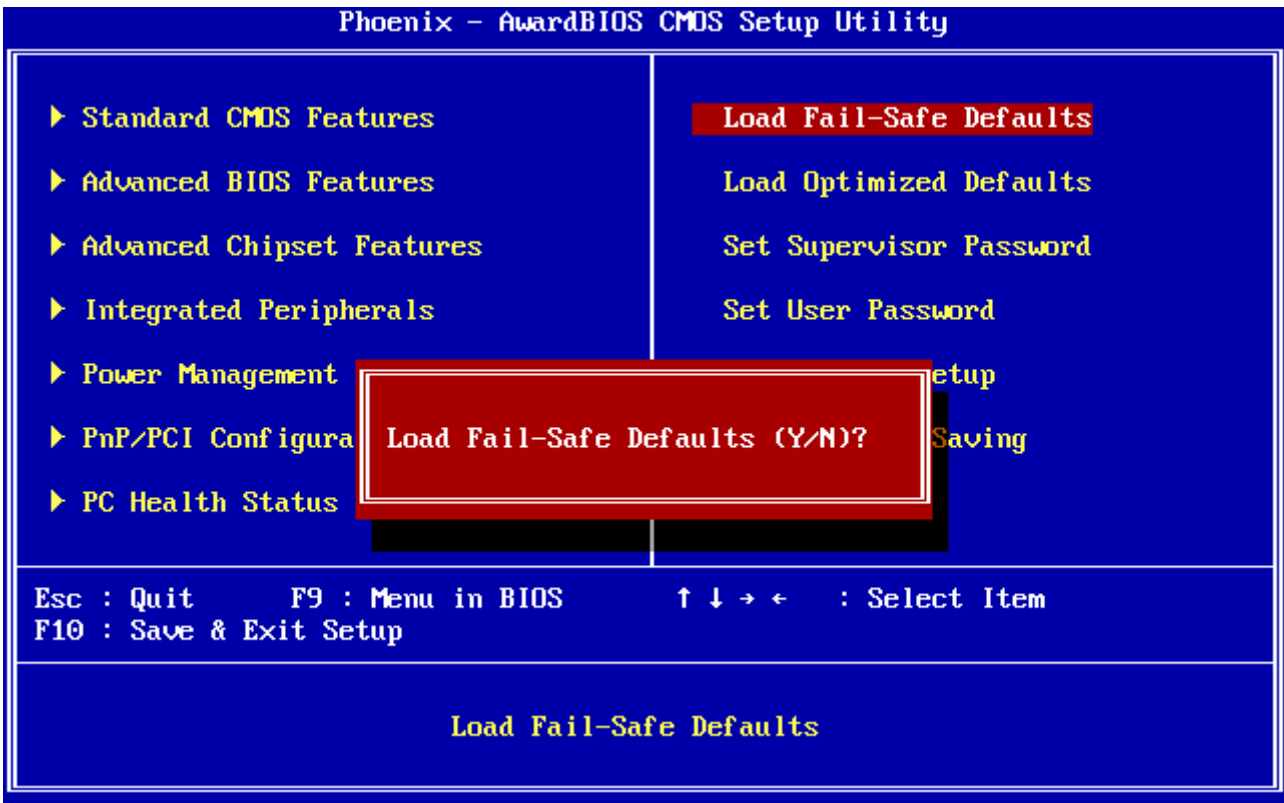

3.5.9.2 Load Optimized Defaults

Use this menu to load the BIOS default values that are factory settings for optimal performance system operations. While Award has designed the custom BIOS to maximize performance, the factory has the right to change these defaults to meet their needs. Press <Y> to load the default values setting for optimal performance system operations.

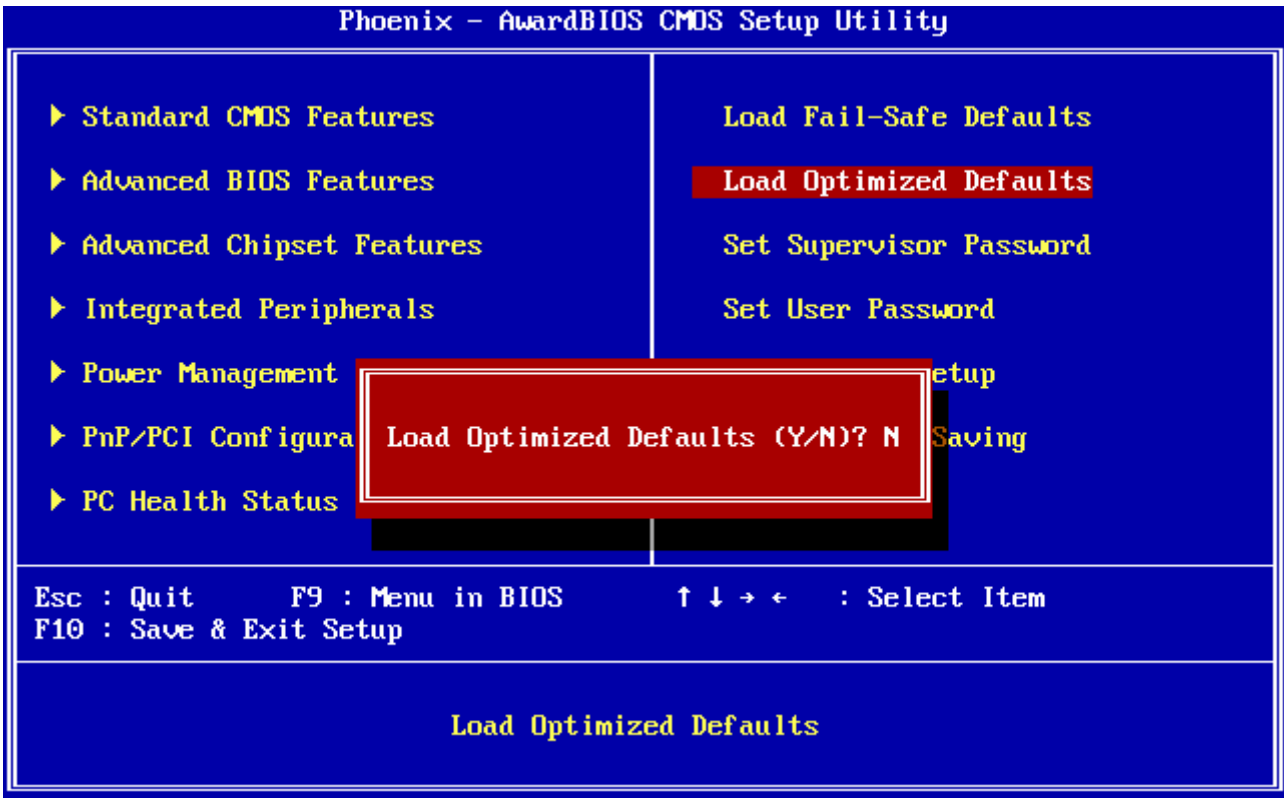

3.5.10.2 Set Supervisor / User Password

You can set either supervisor or user password, or both of them.

Supervisor Password: able to enter/change the options of setup menus.

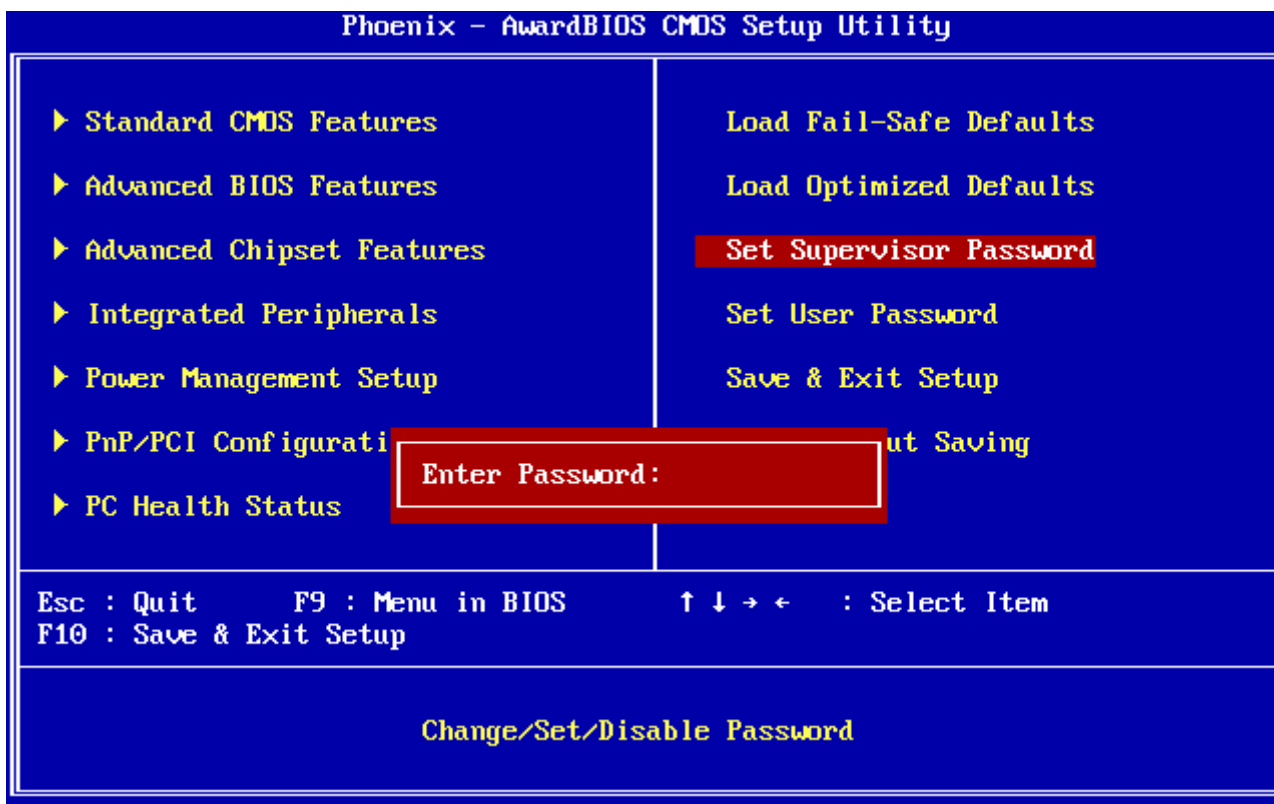

User Password: able to enter but no right to change the options of setup menus.

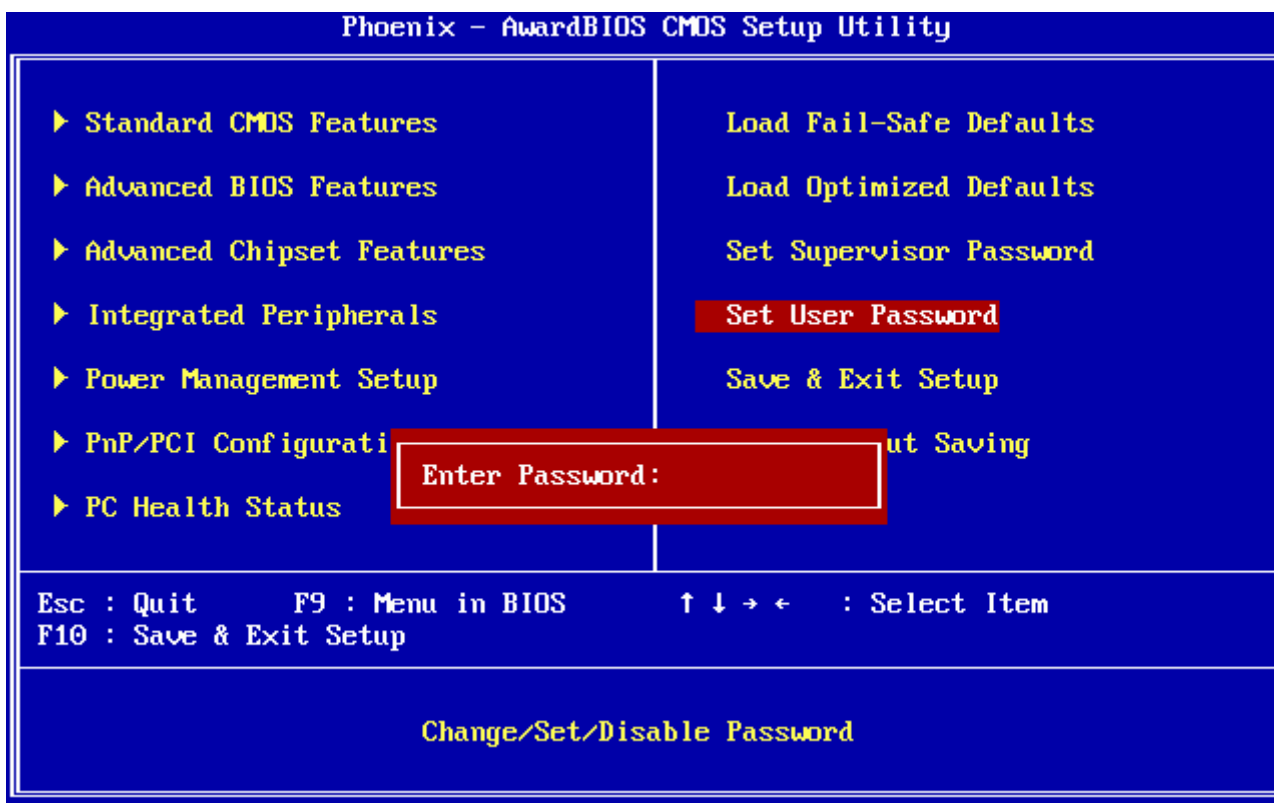

ECM-LX800D

Type the password, up to eight characters in length, and press <Enter>. The password typed now will clear any previously entered password from CMOS memory. You will be asked to confirm the password. Type the password again and press <Enter>. You may also press <Esc> to abort the selection and not enter a password. To disable a password, just press <Enter> when you are prompted to enter the password. A message will confirm the password will be disabled. Once the password is disabled, the system will boot and you can enter Setup freely.

PASSWORD DISABLED.

When a password has been enabled, you will be prompted to enter it every time you try to enter Setup. This prevents an unauthorized person from changing any part of your system configuration. Additionally, when a password is enabled, you can also require the BIOS to request a password every time your system is rebooted. This would prevent unauthorized use of your computer. You determine when the password is required within the BIOS Features Setup Menu and its Security option (see Section 3). If the Security option is set to "System", the password will be required both at boot and at entry to Setup. If set to "Setup", prompting only occurs when trying to enter Setup

3.5.11.2 Save & Exit Setup

Save CMOS value changes to CMOS and exit setup.

Enter <Y> to store the selection made in the menus in CMOS, a special section in memory that stays on after turning the system off. The BIOS configures the system according to the Setup selection stored in CMOS when boot the computer next time.

The system is restarted after saving the values.

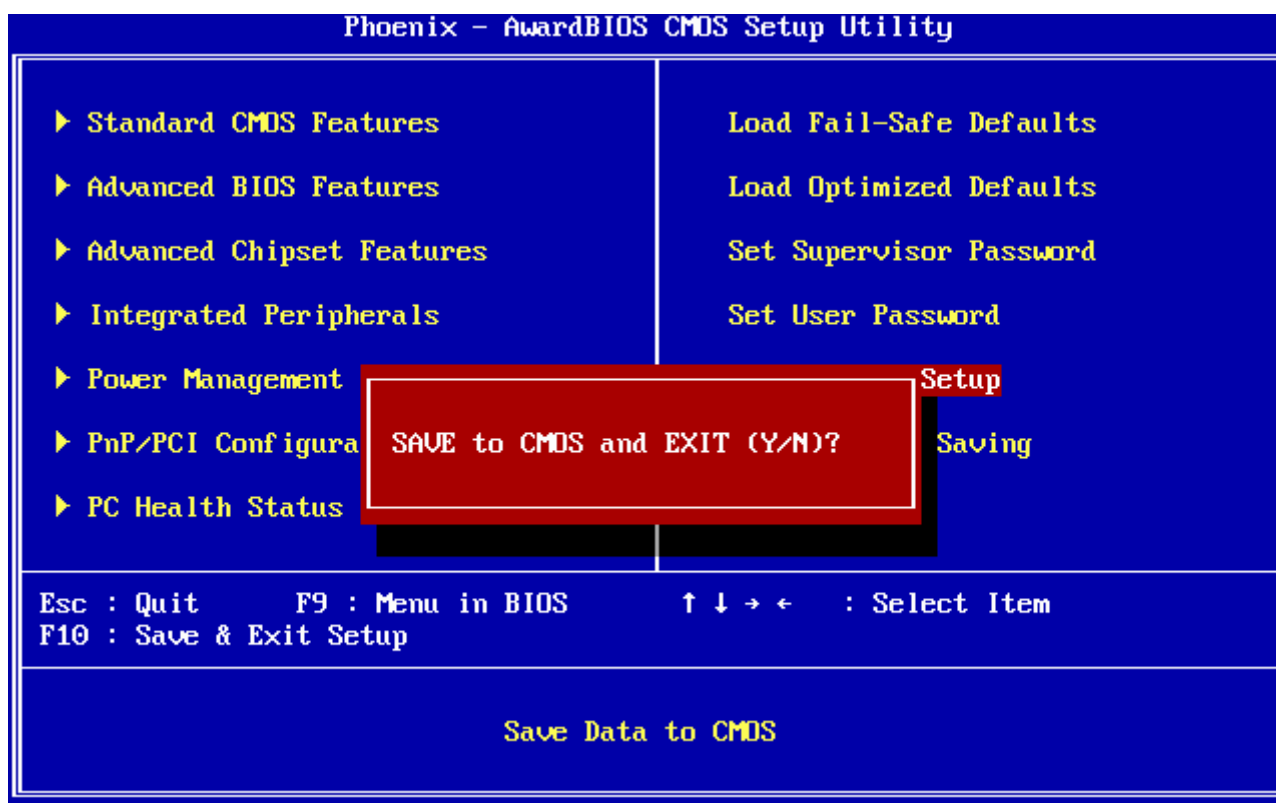

ECM-LX800D

3.5.12.2 Exit Without Save

Abandon all CMOS value changes and exit setup, and the system is restarted after exiting.

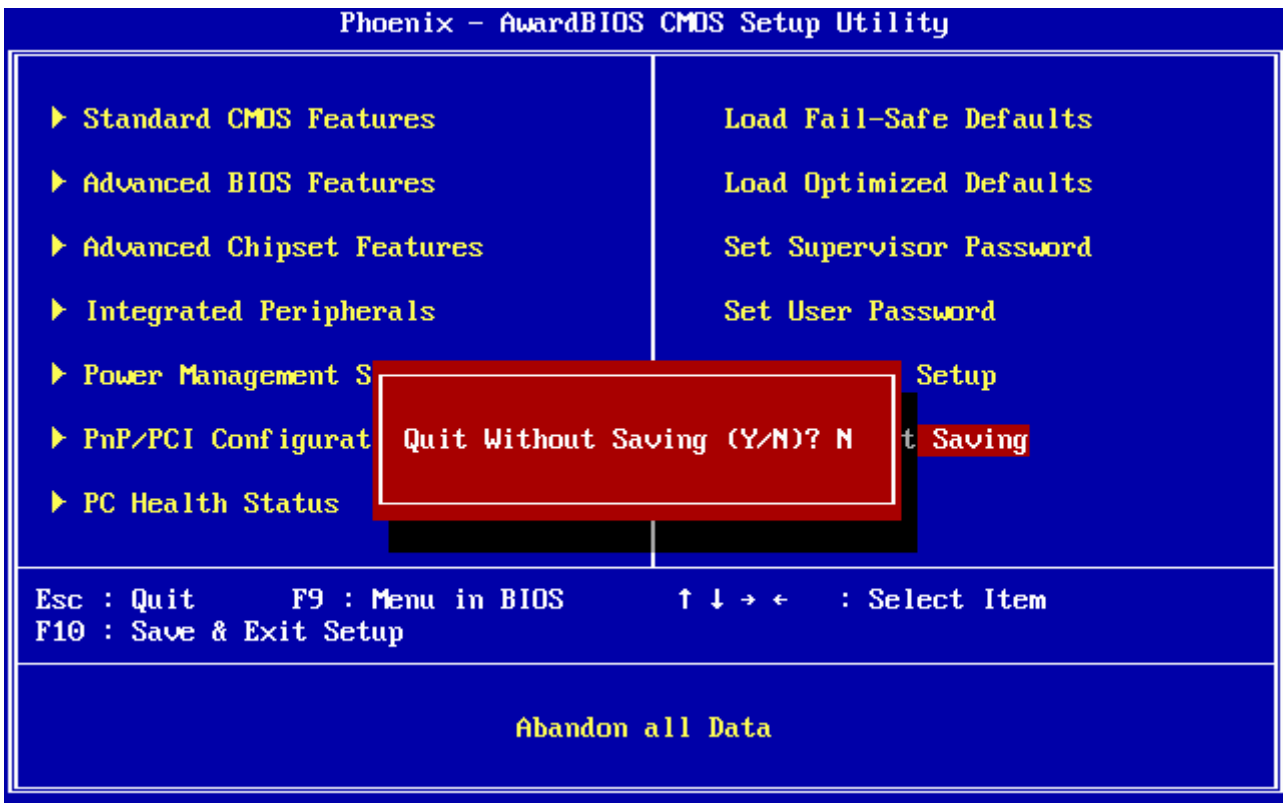

4 Drivers Installation



Note: Installation procedures and screen shots in this section are for your reference and may not be exactly the same as shown on your screen.

4.1 Install Audio Driver (For AMD LX800)

Insert the Supporting CD-ROM to CD-ROM drive, and it should show the index page of Evalue's products automatically. If not, locate Index.htm and choose the product from the menu left, or link to `\\Driver_Audio\AMD\GX3`.



Note: The installation procedures and screen shots in this section are based on Windows XP operation system.

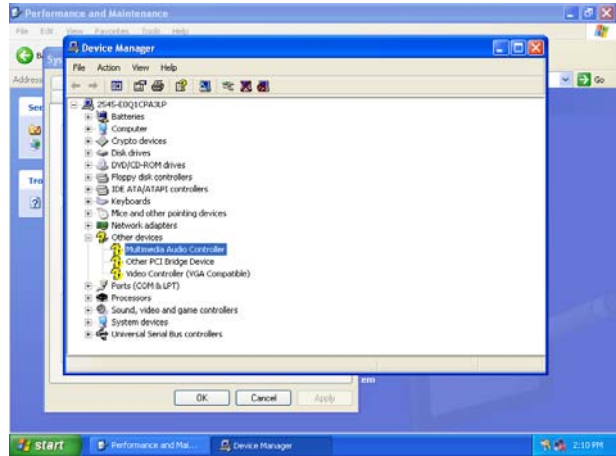

Step 3. Select Multimedia Audio Controller to Reinstall Driver.

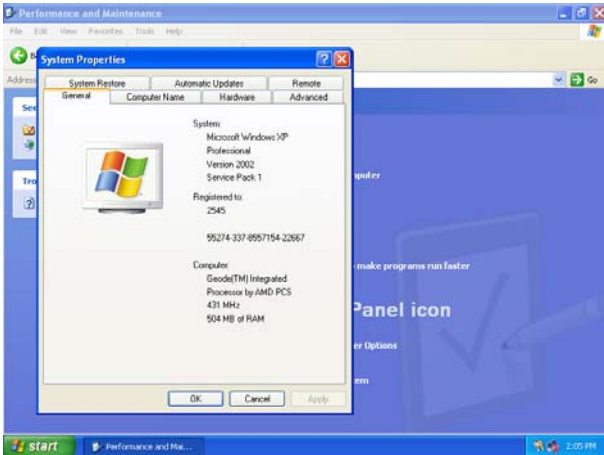

Step 1. Click Start of the task bar, then the System of Performance and Maintenance in Control Panel.

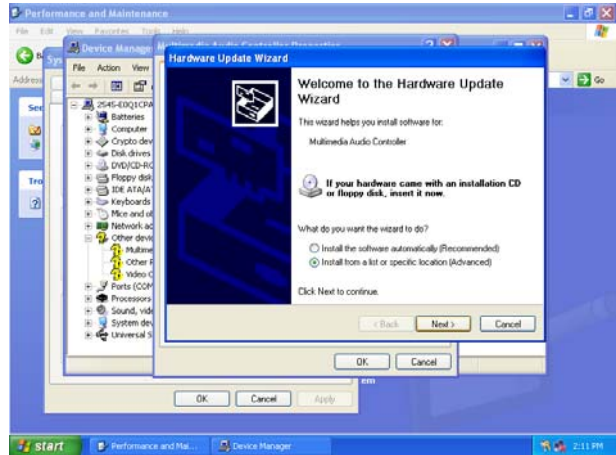

Step 4. Select the Advanced item and click Next.

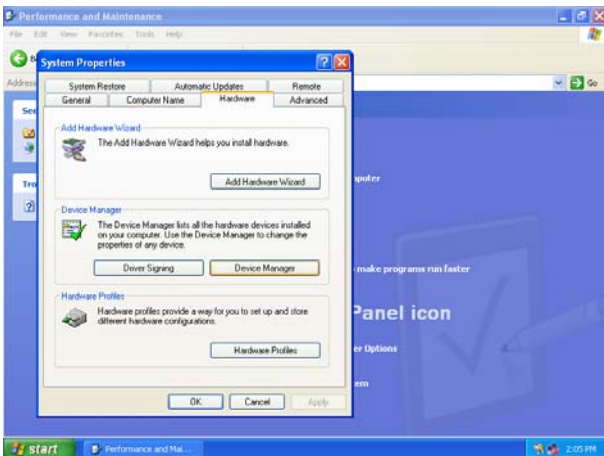

Step 2. Click Device Manager of Hardware.

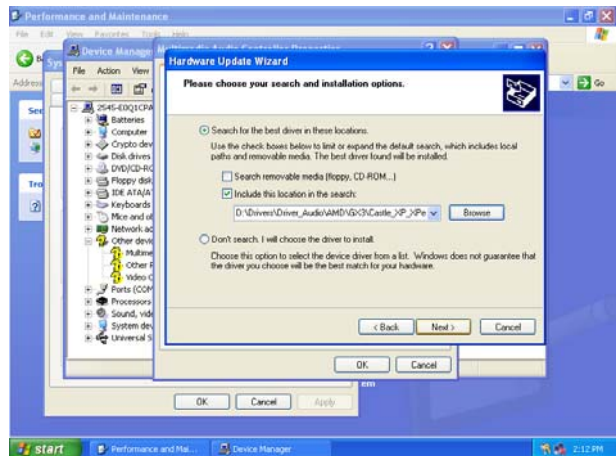

Step 5. Select the specific location to Next.

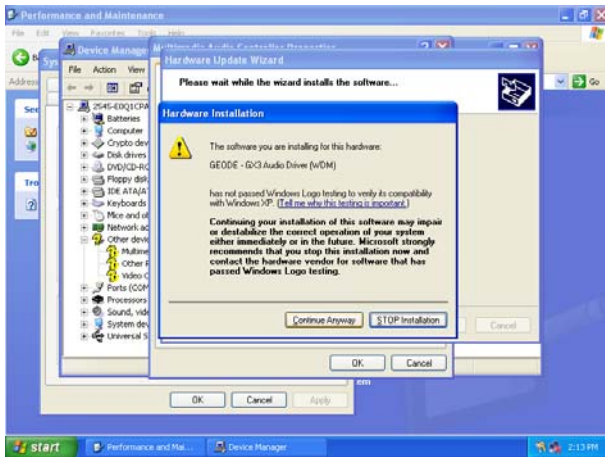

Step6. Click **Continue Anyway** to run the installation.

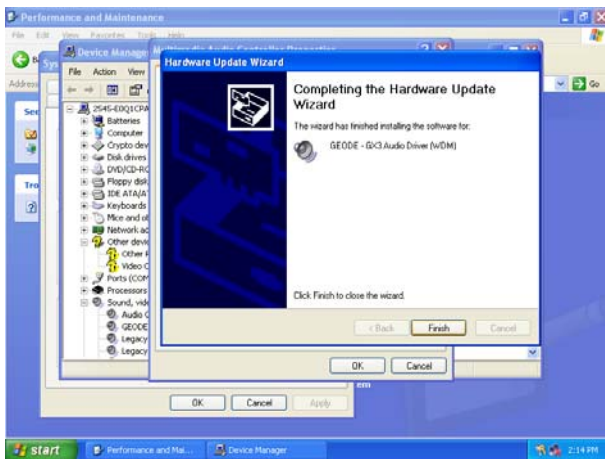

Step7. Click **Finish** to complete the setup.

4.2 Install Chipset Driver (For AMD LX800)

Insert the Supporting CD-ROM to CD-ROM drive, and it should show the index page of Evalue's products automatically. If not, locate Index.htm and choose the product from the menu left, or link to \Driver_Chipset\AMD\GX3.



Note: The installation procedures and screen shots in this section are based on Windows XP operation system.

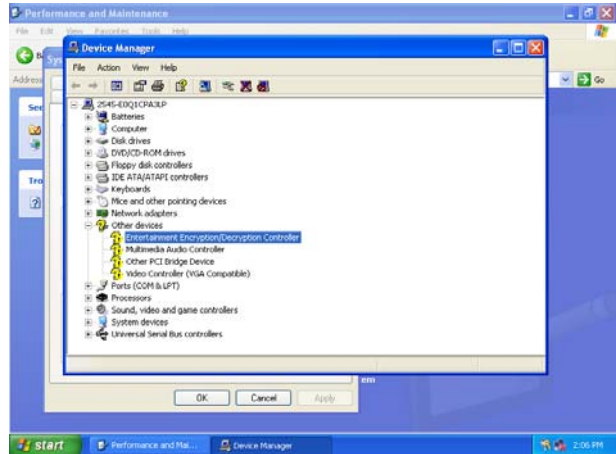

Step 3. Select **Entertainment...** to Reinstall Driver.

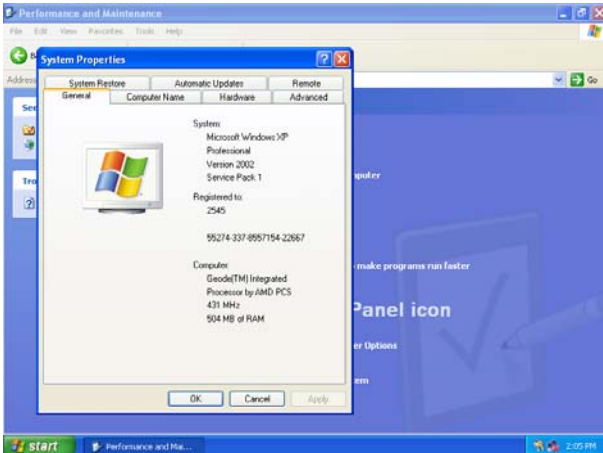

Step 1. Click **Start** of the task bar, then the **System** of **Performance and Maintenance** in **Control Panel**.

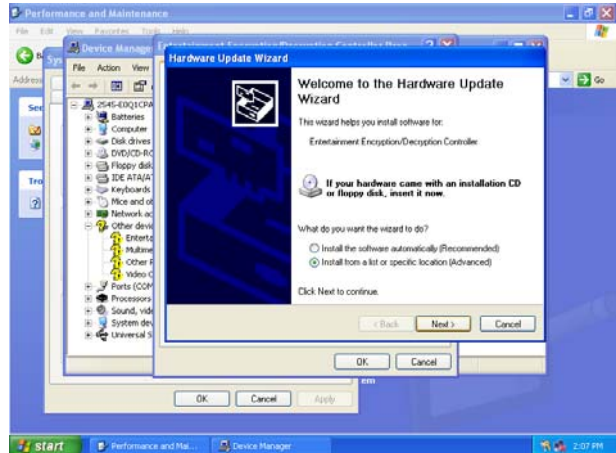

Step 4. Select the **Advanced** item and click **Next**.

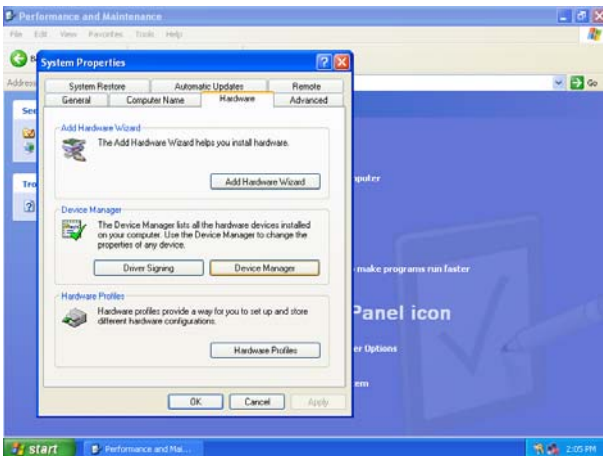

Step 2. Click **Device Manager** of **Hardware**.

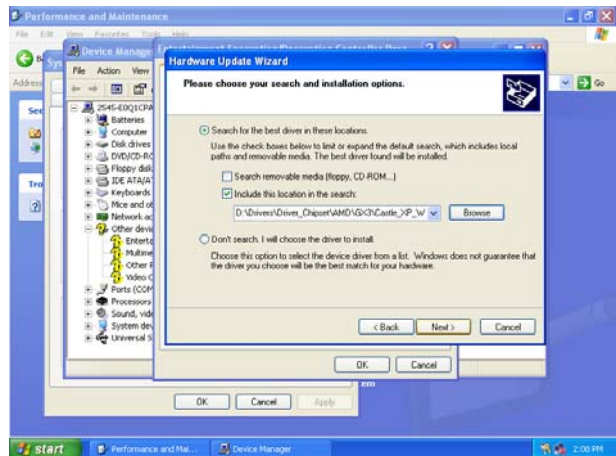

Step 5. Select the specific location to **Next**.

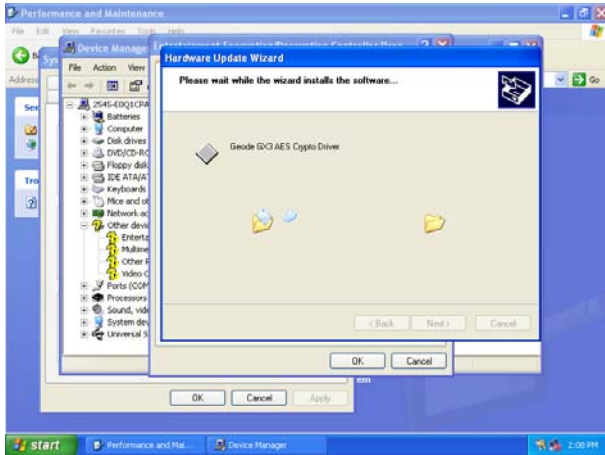

Step6. The setup will install automatically.

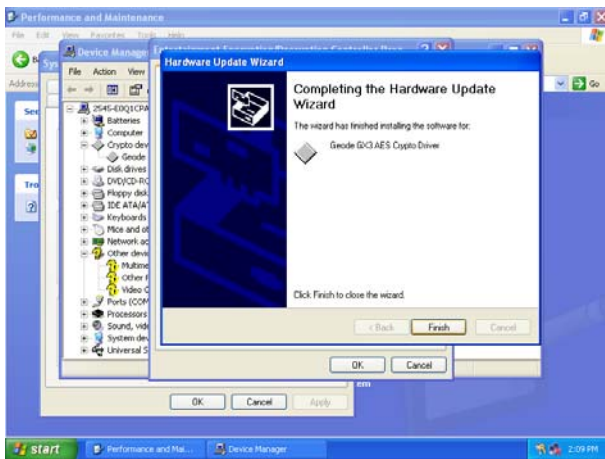

Step7. Click **Finish** to complete the setup.

4.3 Install PCI to ISA Bridge Driver (For ITE IT8888)

Insert the Supporting CD-ROM to CD-ROM drive, and it should show the index page of Evalue's products automatically. If not, locate Index.htm and choose the product from the menu left, or link to \Driver_Chipset\AMD\GX3\PCI to ISA Bridge.



Note: The installation procedures and screen shots in this section are based on Windows XP operation system.

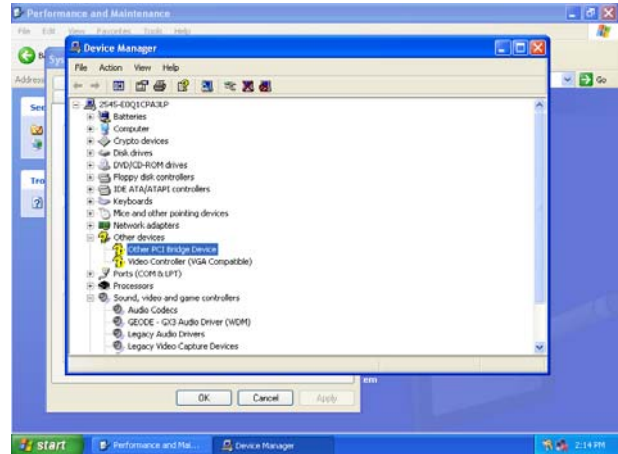

Step 3. Select Other PCI Bridge Device to Reinstall Driver.

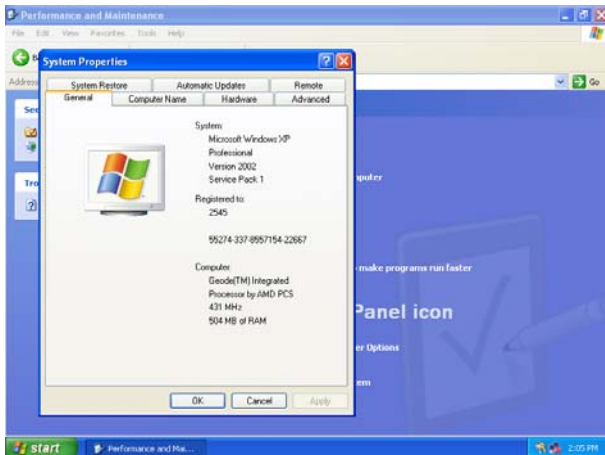

Step 1. Click Start of the task bar, then the System of Performance and Maintenance in Control Panel.

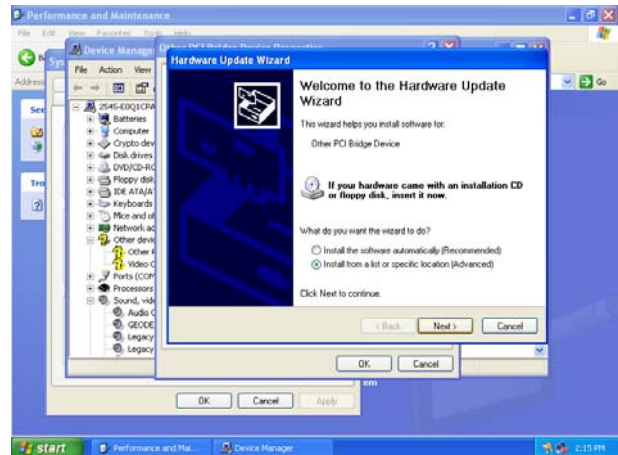

Step 4. Select the Advanced item and click Next.

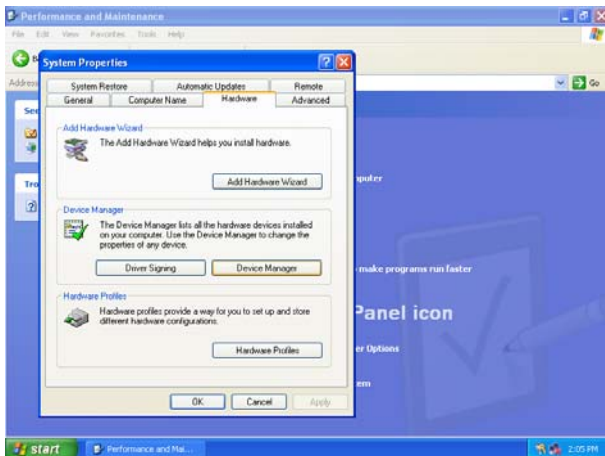

Step 2. Click Device Manager of Hardware.

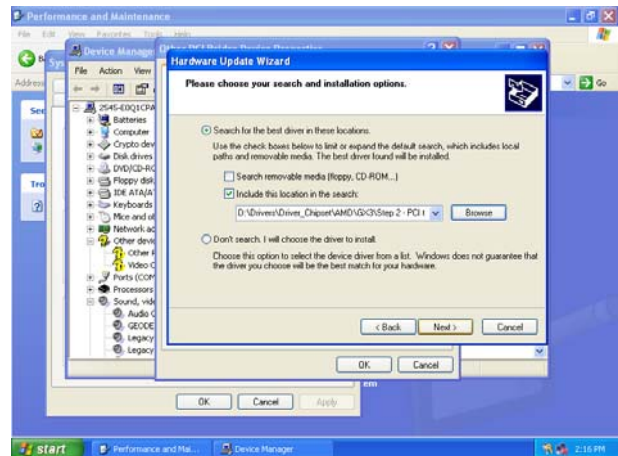

Step 5. Select the specific location to Next.

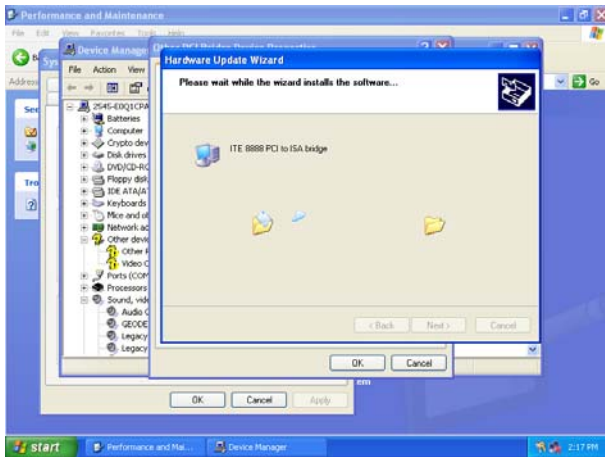

Step6. The setup will install automatically.

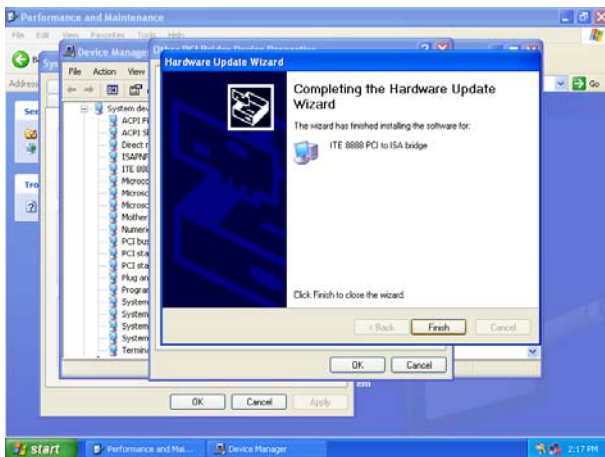

Step7. Click **Finish** to complete the setup.

4.4 Install Display Driver (For AMD LX800)

Insert the Supporting CD-ROM to CD-ROM drive, and it should show the index page of Evalve's products automatically. If not, locate Index.htm and choose the product from the menu left, or link to `\\Driver_Video\AMD\GX3`.



Note: The installation procedures and screen shots in this section are based on Windows XP operation system.

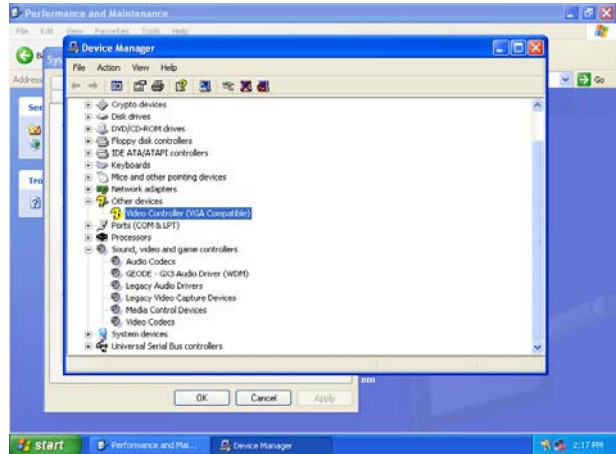

Step 3. Select Video Controller (VGA Compatible) to Reinstall Driver.

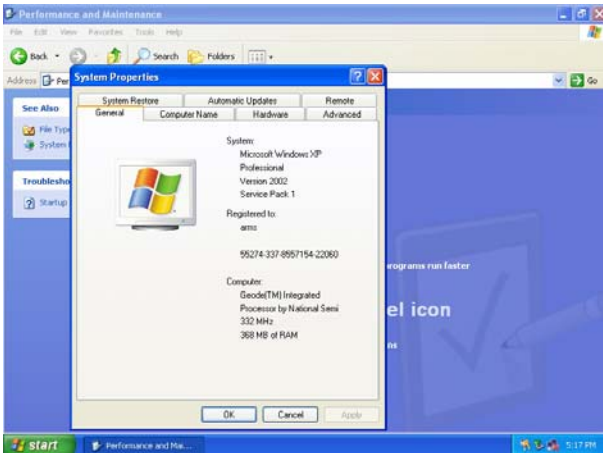

Step 1. Click Start of the task bar, then the System of Performance and Maintenance in Control Panel.

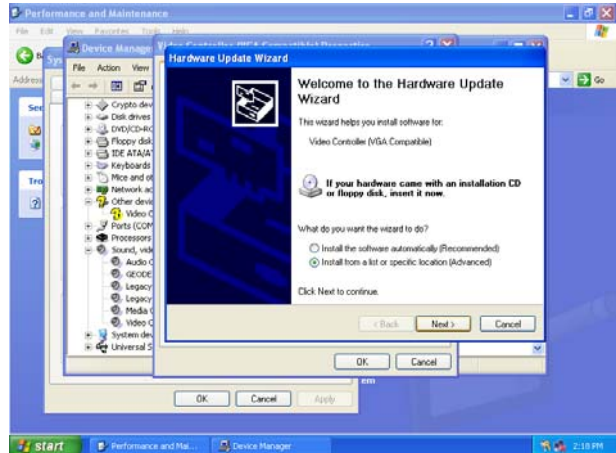

Step 4. Select the Advanced item and click Next.

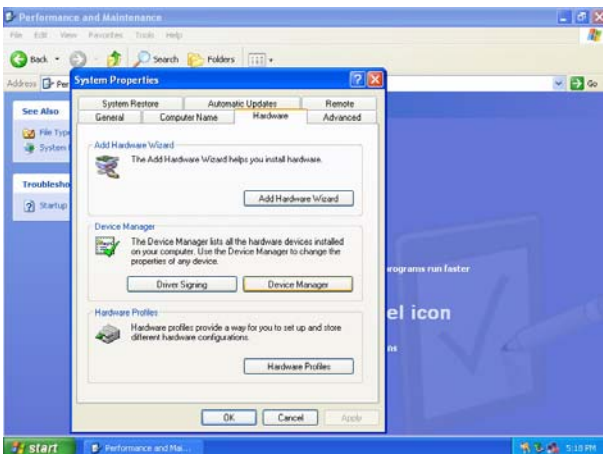

Step 2. Click Device Manager of Hardware.

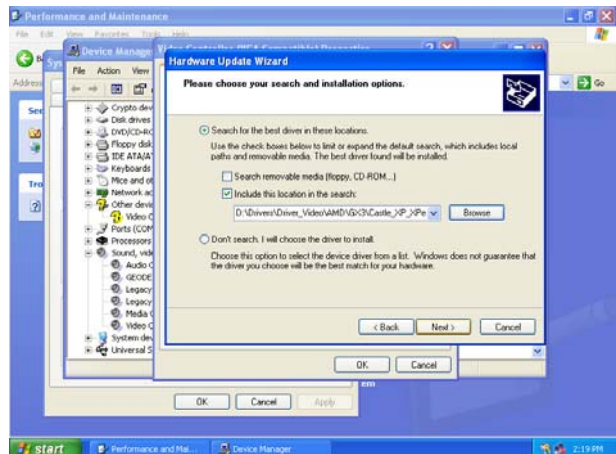

Step 5. Select the specific location to Next.

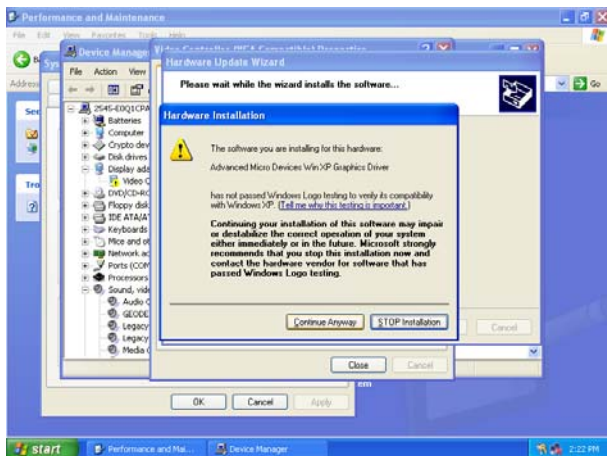

Step6. Click **Continue Anyway** to run the installation.

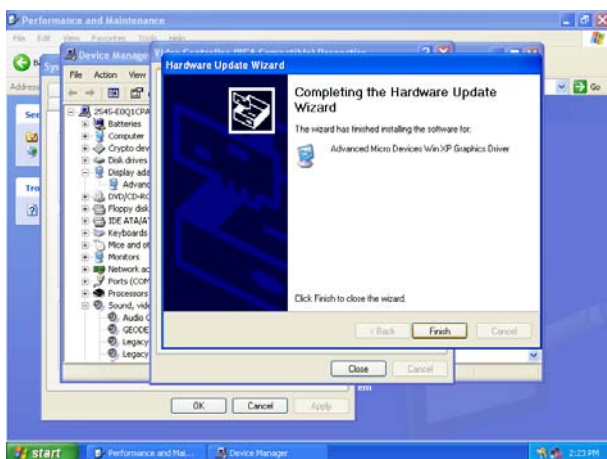

Step7. Click **Finish** to complete the setup.

4.5 Install Ethernet Driver (For Realtek RTL810x, RTL813x Family)

Insert the Supporting CD-ROM to CD-ROM drive, and it should show the index page of Aualue's products automatically. If not, locate Index.htm and choose the product from the menu left, or link to **\Driver_Network\Realtek\RTL810x_813X Family**.



Note: The installation procedures and screen shots in this section are based on Windows XP operation system.

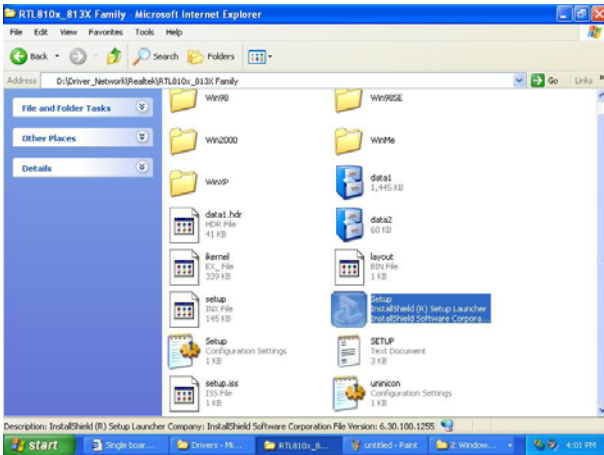

Step 1. Locate 「\Driver_Network\Realtek\RTL810x_813X Family\Setup.exe」.

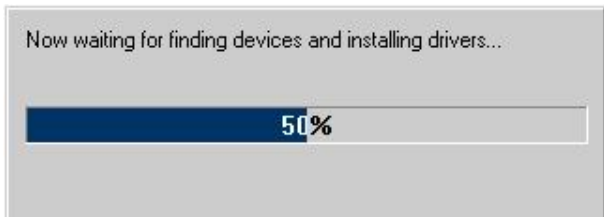
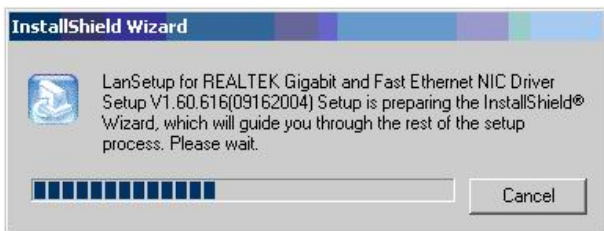

Step 2. Setup executing.

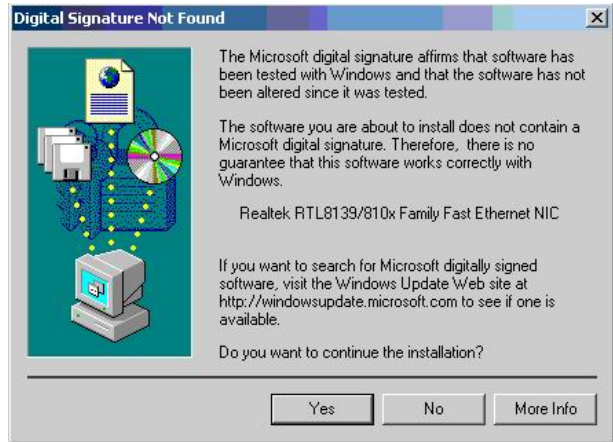

Step 3. Click **Yes** to continue the installation.

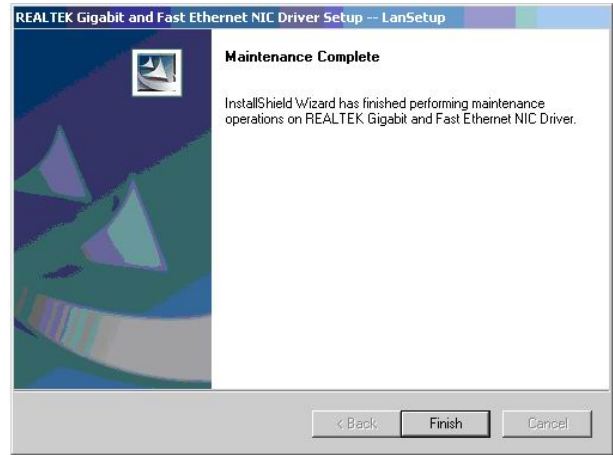

Step 4. Click **Finish** to complete the setup.

5 Mechanical Drawing

Appendix A:

Chipset Introduction

[AMD LX800 & CS5536](#)

[Realtek ALC203 Audio Codec](#)

[Realtek RTL8101L Ethernet Controller](#)

[ITE IT8888 PCI to ISA Bridge](#)

[Compact Flash Interface](#)

ECM-LX800D

— AMD LX800 & CS5536

The AMD Geode™ LX 800@0.9W processor brings x86 power and versatility to applications for entertainment, business, education, and embedded markets. The AMD Geode LX processors' integrated, innovative architecture delivers the most performance per watt available in the industry today, and can lead to longer battery life and enable small form-factor designs.

The AMD Geode LX processor family offers new levels of performance and power versatility in an x86-based embedded processor. The AMD Geode LX 800@0.9W processor operates at a maximum power of 3.9W (TDP) and 1.8W typical at 500MHz. The device are exceptional for such applications as thin clients, interactive set-top boxes, single board computers, Personal Access Devices (PADs), mobile Internet, and entertainment. Designers can now focus on developing end products that efficiently meet consumer needs with far fewer limits imposed by software porting or compatibility.

The AMD Geode LX processors deliver the low-power x86 performance to design innovative and creative new products without compromise. Coupled with the AMD Geode™ CS5536 companion device, the combined chipset, which operates at 1.9W typical at 433MHz and at 2.4W typical at 500MHz, offers designers a complete set of features that can deliver full desktop functionality to embedded and portable devices.

Capabilities include:

- Natively run all Windows® and Linux based applications
- Full Internet browser experience on portable devices
- High-performance patented GeodeLink™ architecture
- No software porting needed – programs run without modification
- Access to the full universe of 32-bit x86 software
- Support for any type of connectivity

The AMD commitment to the x86 marketplace, with a range of high-performance products like AMD Geode™ LX processors, gives OEMs an easy and effective way to achieve product differentiation and shorten time-to-market cycles. The AMD Geode LX processors are the next step in helping AMD redefine the way x86 processors address the growing need for versatile power and performance for a variety of consumer devices. It is the latest example of AMD's commitment to make x86-based technology available for a variety of applications –from high-end servers to low-power embedded applications.

Processor functional blocks

- CPU Core
- GeodeLink™ Control Processor
- GeodeLink Interface Units

- GeodeLink Memory Controller
- Graphics Processor
- Display Controller
- Video Processor
- Video Input Port
- GeodeLink PCI Bridge
- Security Block

The AMD Geode™ CS5536 companion device works with both AMD Geode™ LX and AMD Geode™ GX processor families to create today's leading high-performance, low-power x86 solution for embedded applications, ranging from thin clients and digital set-top boxes to single-board computers and Personal Access Devices (PADs).

The AMD Geode CS5536 companion device leverages a single, high-performance modular structure based on AMD GeodeLink™ architecture. This configuration provides internal data speeds above 1 GB/second, and highly versatile internal power management.

Together with the AMD Geode LX and GX processor, the AMD Geode CS5536 companion device designers a complete processing solution for developing a variety of end-user devices that require high-performance x86-based processing and low power usage. The companion device complements the features built into the AMD Geode LX and GX processors, and includes integrated controllers for audio, hard disk drive (ATA-6) USB 2.0, power management, and more – all based on the innovative GeodeLink architecture.

The AMD AMD Geode™ CS5536 companion device incorporates a full suite of advanced features to enable designers to achieve new levels of performance and creativity with x86-based devices. The companion device contains:

- Versatile I/O functions
- 82xx devices to provide true PC functionality
 - 2 PICs (Programmable Interrupt Controllers)
 - PIT (Programmable Interval Timer) with 3 channels
 - DMA (Direct Memory Access) functions
- Flexible MFGPTs (Multi-Function General Purpose Timers)

General features

- Designed for use with the AMD Geode LX and GX processor families
- 208-Terminal PBGA (Plastic Ball Grid Array) package with internal heatspreader
- 1.2V or 1.25V (nominal) core operation
- Working and Standby power domains
- IEEE 1149.1-compliant TAP and boundary scan

ECM-LX800D

— Realtek ALC203 Audio Codec

The ALC203 is a 20-bit DAC and 18-bit ADC full-duplex AC'97 2.3 compatible stereo audio CODEC designed for PC multimedia systems, including host/soft audio, and AMR/CNR based designs.

The ALC203 incorporates proprietary converter technology to achieve a high SNR (greater than 100 dB), sensing logics for device reporting, and a Universal Audio Jack® for improved user convenience. The ALC203 AC'97 CODEC supports multiple CODEC extensions with independent variable sampling rates and built-in 3D effects. The ALC203 CODEC provides two pairs of stereo outputs with independent volume controls, a mono output, multiple stereo and mono inputs, along with flexible mixing, gain, and mute functions to provide a complete integrated audio solution for PCs.

— Ethernet

Realtek RTL8101L Ethernet Controller

The Realtek RTL8101L is a single-chip Fast Ethernet controller that provides 32-bit performance, PCI bus master capability, and full compliance with IEEE 802.3u 100Base-TX specifications and IEEE 802.3x Full Duplex Flow Control. It also supports the Advanced Configuration Power management Interface (ACPI), PCI power management for modern operating systems that are capable of Operating System Directed Power Management (OSPM) to achieve the most efficient power management possible. The RTL8101L no longer supports CardBus mode as RTL8139C does.

In addition to the ACPI feature, the RTL8101L also supports remote wake-up (including AMD Magic Packet, LinkChg, and Microsoft® wake-up frame) in both ACPI and APM environments. The RTL8101L is capable of performing an internal reset through the application of auxiliary power. When auxiliary power is applied and the main power remains off, the RTL8101L is ready and waiting for the Magic Packet or Link Change to wake the system up. Also, the LWAKE pin provides 4 different output signals including active high, active low, positive pulse, and negative pulse. The versatility of the RTL8101L LWAKE pin provides motherboards with Wake-On-LAN (WOL) functionality.

The RTL8101L also supports Analog Auto-Power-down, that is, the analog part of the RTL8101L can be shut down temporarily according to user requirements or when the RTL8101L is in a power down state with the wakeup function disabled. In addition, when the analog part is shut down and the IsolateB pin is low (i.e. the main power is off), then both the analog and digital parts stop functioning and the power consumption of the RTL8101L will be negligible. The RTL8101L also supports an auxiliary power auto-detect function, and will auto-configure related bits of their own PCI power management registers in PCI configuration space.

PCI Vital Product Data (VPD) is also supported to provide the information that uniquely identifies hardware (i.e., the OEM brand name of RTL8101L LAN card). The information may consist of part number, serial number, and other detailed information.

To provide cost down support, the RTL8101L is capable of using a 25MHz crystal or OSC as its internal clock source. The RTL8101L keeps network maintenance costs low and eliminates usage barriers. It is the easiest way to upgrade a network from 10 to 100Mbps. It also supports full-duplex operation, making 200Mbps bandwidth possible at no additional cost. To improve compatibility with other brands' products, the RTL8101L is also capable of receiving packets with InterFrameGap no less than 40 Bit-Time. The RTL8101L is highly integrated and requires no "glue" logic or external memory.

The RTL8101L includes a PCI and Expansion Memory Share Interface (Realtek patent) for a boot ROM and can be used in diskless workstations, providing maximum network security and ease of management.

— **ITE IT8888 PCI to ISA Bridge**

The IT8888F/G is a PCI to ISA bridge single function device. The IT8888F/G serves as a bridge between the PCI bus and ISA bus. The IT8888F/G's 32-bit PCI bus interface is compliant with PCI Specification V2.1 and supports both PCI Bus Master & Slave. The PCI interface supports both programmable positive and full subtractive decoding schemes.

The IT8888F/G also integrates two enhanced DMA Slave controllers for achieving PCI DMA cycles: PC/PCI DMA Slave Controller & Distributed DMA Slave Controllers.

The device also contains one SM bus (single master mode) which can be connected to a Serial E2PROM for automatic power-on configuration. ITE's proprietary (USA & Taiwan patent pending) power-on auto-configuration through SM bus can provide customer with maximum design flexibility. The IT8888F/G also implements the optional fast positive decode of F, E, D, C memory segments. This special feature can provide a direct connection to an FLASH boot ROM.

The NOGO function, which is also implemented in the IT8888F/G for enabling or disabling subtractive decode of PCI interface could be a software controlled output pin from other host controlled devices. The Serial IRQ is also implemented in the device for sending and receiving ISA IRQs & IOCHCK#. The device includes an ISA interface which supports full ISA compatible functions.

— **Compact Flash Interface**

A Compact Flash type II connector is connected to the secondary IDE controller. The Compact Flash storage card is IDE compatible. It is an ideal replacement for standard IDE hard drives. The solid-state design offers no seek errors even under extreme shock and vibration conditions. The Compact Flash storage card is extremely small and highly suitable for rugged environments, thus providing an excellent solution for mobile applications with space limitations. It is fully compatible with all consumer applications designed for data storage PC card, PDA, and Smart Cellular Phones, allowing simple use for the end user.

ECM-LX800D

The Compact Flash storage card is O/S independent, thus offering an optimal solution for embedded systems operating in non-standard computing environments. The Compact Flash storage card is IDE compatible and offers various capacities.

Appendix B:

AWARD BIOS POST

Messages

Overview

During the Power On Self-Test (POST), if the BIOS detects an error requiring you to do something to fix, it will either sound a beep code or display a message.

If a message is displayed, it will be accompanied by:

PRESS F1 TO CONTINUE OR PRESS DEL TO ENTER SETUP

Post Beep

Currently there are two kinds of beep codes in BIOS. This code indicates that a video error has occurred and the BIOS cannot initialize the video screen to display any additional information. This beep code consists of a single long beep followed by two short beeps. The other code indicates that your DRAM error has occurred. This beep code consists of a single long beep repeatedly.

Error Messages

The following messages are examples of messages including errors detected by the BIOS during POST and a description of what they mean and/or what you may do to correct the error.

1. CMOS BATTERY HAS FAILED

CMOS battery is no longer functional. It should be replaced.

2. CMOS CHECKSUM ERROR

Checksum of CMOS is incorrect. This can indicate that CMOS has become corrupt. This error may have been caused by a weak battery. Check the battery and replace if necessary.

3. DISK BOOT FAILURE, INSERT SYSTEM DISK AND PRESS ENTER

No boot device was found. This could mean that either a boot drive was not detected or the drive does not contain proper system boot files. Insert a system disk into Drive A: and press <Enter>. If you assumed the system would boot from the hard drive, make sure the controller is inserted correctly and all cables are properly attached. Also be sure the disk is formatted as a boot device. Then reboot the system.

4. DISKETTE DRIVES OR TYPES MISMATCH ERROR - RUN SETUP

Type of diskette drive installed in the system is different from the CMOS definition. Run Setup to reconfigure the drive type correctly.

5. DISPLAY SWITCH IS SET INCORRECTLY

Display switch on the motherboard can be set to either monochrome or color. This indicates the switch is set to a different setting than indicated in Setup. Determine which setting is correct, and then either turn off the system and change the jumper, or enter Setup and change the VIDEO selection.

6. DISPLAY TYPE HAS CHANGED SINCE LAST BOOT

Since last powering off the system, the display adapter has been changed. You must configure the system for the new display type.

7. EISA Configuration Checksum Error**PLEASE RUN EISA CONFIGURATION UTILITY**

The EISA non-volatile RAM checksum is incorrect or cannot correctly read the EISA slot. This can indicate either the EISA non-volatile memory has become corrupt or the slot has been configured incorrectly. Also be sure the card is installed firmly in the slot.

8. EISA Configuration Is Not Complete**PLEASE RUN EISA CONFIGURATION UTILITY**

The slot configuration information stored in the EISA non-volatile memory is incomplete.



Note: When either of these errors appears, the system will boot in ISA mode, which allows you to run the EISA Configuration Utility.

9. ERROR ENCOUNTERED INITIALIZING HARD DRIVE

Hard drive cannot be initialized. Be sure the adapter is installed correctly and all cables are correctly and firmly attached. Also be sure the correct hard drive type is selected in Setup.

10. ERROR INITIALIZING HARD DISK CONTROLLER

Cannot initialize controller. Make sure the cord is correctly and firmly installed in the bus. Be sure the correct hard drive type is selected in Setup. Also check to see if any jumper needs to be set correctly on the hard drive.

11. FLOPPY DISK CNTRLR ERROR OR NO CNTRLR PRESENT

Cannot find or initialize the floppy drive controller. Make sure the controller is installed correctly and firmly. If there are no floppy drives installed, be sure the Diskette Drive selection in Setup is set to NONE.

12. Invalid EISA Configuration

PLEASE RUN EISA CONFIGURATION UTILITY

The non-volatile memory containing EISA configuration information was programmed incorrectly or has become corrupt. Re-run EISA configuration utility to correctly program the memory.



Note: When either of these errors appears, the system will boot in ISA mode, which allows you to run the EISA Configuration Utility.

13. KEYBOARD ERROR OR NO KEYBOARD PRESENT

Cannot initialize the keyboard. Make sure the keyboard is attached correctly and no keys are being pressed during the boot.

If you are purposely configuring the system without a keyboard, set the error halt condition in Setup to HALT ON ALL, BUT KEYBOARD. This will cause the BIOS to ignore the missing keyboard and continue the boot.

14. Memory Address Error at ...

Indicates a memory address error at a specific location. You can use this location along with the memory map for your system to find and replace the bad memory chips.

15. Memory parity Error at ...

Indicates a memory parity error at a specific location. You can use this location along with the memory map for your system to find and replace the bad memory chips.

16. MEMORY SIZE HAS CHANGED SINCE LAST BOOT

Memory has been added or removed since the last boot. In EISA mode use Configuration Utility to reconfigure the memory configuration. In ISA mode enter Setup and enter the new memory size in the memory fields.

17. Memory Verify Error at ...

Indicates an error verifying a value already written to memory. Use the location along with your system's memory map to locate the bad chip.

18. OFFENDING ADDRESS NOT FOUND

This message is used in conjunction with the I/O CHANNEL CHECK and RAM PARITY ERROR messages when the segment that has caused the problem cannot be isolated.

19. OFFENDING SEGMENT:

This message is used in conjunction with the I/O CHANNEL CHECK and RAM PARITY ERROR messages when the segment that has caused the problem has been isolated.

20. PRESS A KEY TO REBOOT

This will be displayed at the bottom screen when an error occurs that requires you to reboot. Press any key and the system will reboot.

21. PRESS F1 TO DISABLE NMI, F2 TO REBOOT

When BIOS detects a Non-maskable Interrupt condition during boot, this will allow you to disable the NMI and continue to boot, or you can reboot the system with the NMI enabled.

22. RAM PARITY ERROR - CHECKING FOR SEGMENT ...

Indicates a parity error in Random Access Memory.

23. Should Be Empty But EISA Board Found**PLEASE RUN EISA CONFIGURATION UTILITY**

A valid board ID was found in a slot that was configured as having no board ID.



Note: When either of these errors appears, the system will boot in ISA mode, which allows you to run the EISA Configuration Utility.

24. Should Have EISA Board But Not Found**PLEASE RUN EISA CONFIGURATION UTILITY**

The board installed is not responding to the ID request, or no board ID has been found in the indicated slot.



Note: When either of these errors appears, the system will boot in ISA mode, which allows you to run the EISA Configuration Utility.

25. Slot Not Empty

Indicates that a slot designated as empty by the EISA Configuration Utility actually contains a board.



Note: When either of these errors appears, the system will boot in ISA mode, which allows you to run the EISA Configuration Utility.

26. SYSTEM HALTED, (CTRL-ALT-DEL) TO REBOOT ...

Indicates the present boot attempt has been aborted and the system must be rebooted. Press and hold down the CTRL and ALT keys and press DEL.

27. Wrong Board In Slot

PLEASE RUN EISA CONFIGURATION UTILITY

The board ID does not match the ID stored in the EISA non-volatile memory.



Note: When either of these errors appears, the system will boot in ISA mode, which allows you to run the EISA Configuration Utility.

28. FLOPPY DISK(S) fail (80) → Unable to reset floppy subsystem.

29. FLOPPY DISK(S) fail (40) → Floppy Type mismatch.

30. Hard Disk(s) fail (80) → HDD reset failed.

31. Hard Disk(s) fail (40) → HDD controller diagnostics failed.

32. Hard Disk(s) fail (20) → HDD initialization error.

33. Hard Disk(s) fail (10) → Unable to recalibrate fixed disk.

34. Hard Disk(s) fail (08) → Sector Verify failed.

35. Keyboard is locked out - Unlock the key.

BIOS detect the keyboard is locked. P17 of keyboard controller is pulled low.

36. Keyboard error or no keyboard present.

Cannot initialize the keyboard. Make sure the keyboard is attached correctly and no keys are being pressed during the boot.

37. Manufacturing POST loop.

System will repeat POST procedure infinitely while the P15 of keyboard controller is pull low. This is also used for M/B burn in test.

38. BIOS ROM checksum error - System halted.

The checksum of ROM address F0000H-FFFFFFH is bad.

39. Memory test fail.

BIOS reports the memory test fail if the onboard memory is tested error.

40. POST Codes

Please take reference to Phoenix-Award website for the latest post codes.

<http://www.phoenix.com/NR/rdonlyres/0835996A-6694-4F6D-8243-1030EE040D92/0/postcode.pdf>

40.1 Normal POST Code



Note: EISA POST codes are typically output to port address 300h. ISA POST codes are output to port address 80h.

Code (hex)	Name	Description
C0	Turn Off Chipset and CPU test	OEM Specific-Cache control cache Processor Status (1FLAGS) Verification. Tests the following processor status flags: Carry, zero, sign, overflow, the BIOS sets each flag, verifies They are set, then turns each flag off and verifies it is off. Read/Write/Verify all CPU registers except SS, SP, and BP with data pattern FF and 00. RAM must be periodically refreshed to keep the memory from decaying. This function ensures that the memory refresh function is working properly.
C1	Memory Presence	First block memory detect OEM Specific-Test to size on-board memory. Early chip set initialization Memory presence test OEM chip set routines clear low 64K of memory Test first 64K memory.
C2	Early Memory Initialization	OEM Specific- Board Initialization
C3	Extend Memory DRAM select	OEM Specific- Turn on extended memory Initialization Cyrix CPU initialization, Cache initialization
C4	Special Display Handling	OEM Specific- Display/Video Switch handling so that switch handling display switch errors never occurs
C5	Early Shadow	OEM specific- Early shadow enable for fast boot
C6	Cache presence test	External cache size detection
CF	CMOS Check	CMOS checkup
B0	Spurious	If interrupt occurs in protected mode.
B1	Unclaimed NMI	If unmasked NMI occurs, display Press F1 to disable NMI, F2 reboot.
BF	Program Chip Set	To program chipset from defaults values
E1-EF	Setup Pages	E1- Page 1, E2 - Page 2, etc.
1	Force load Default to chipset	Chipset defaults program
2	Reserved	

ECM-LX800D

Code (hex)	Name	Description
3	Early Superio Init	Early Initialized the super IO
4	Reserved	
5	Blank video	Reset Video controller
6	Reserved	
7	Init KBC	Keyboard controller init
8	KB test	Test the Keyboard
9	Reserved	
A	Mouse Init	Initialized the mouse
B	Onboard Audio init	Onboard audio controller initialize if exist
C	Reserved	
D	Reserved	
E	CheckSum Check	Check the intergraty of the ROM, BIOS and message
F	Reserved	
10	Auto detec EEPROM	Check Flash type and copy flash write/erase routines to 0F000h segments
11	Reserved	
12	Cmos Check	Check Cmos Circuitry and reset CMOS
13	Reserved	
14	Chipset Default load	Program the chipset registers with CMOS values
15	Reserved	
16	Clock Init	Init onboard clock generator
17	Reserved	
18	Identify the CPU	Check the CPU ID and init L1/L2 cache
19	Reserved	
1A	Reserved	
1B	Setup Interrupt Vector Table	Initialize first 120 interrupt vectors with SPURIOUS_INT_HDLR and initialize INT 00h-1Fh according to INT_TBL
1C	Reserved	
1D	Early PM Init	First step initialize if single CPU onboard
1E	Reserved	
1F	Re-initial KB	Re-init KB
20	Reserved	
21	HPM init	If support HPM, HPM get initialized here
22	Reserved	
23	Test CMOS Interface and battery Status	Verifies CMOS is working correctly, detects bad battery. If failed, load CMOS defaults and load into chipset
24	Reserved	

Code (hex)	Name	Description
25	Reserved	
26	Reserved	
27	KBC final Init	Final Initial KBC and setup BIOS data area
28	Reserved	
29	Initialize Video Interface	Read CMOS location 14h to find out type of video in use. Detect and Initialize Video Adapter.
2A	Reserved	
2B	Reserved	
2C	Reserved	
2D	Video memory test	Test video memory, write sign-on message to screen. Setup shadow RAM - Enable shadow according to Setup.
2E	Reserved	
2F	Reserved	
30	Reserved	
31	Reserved	
32	Reserved	
33	PS2 Mouse setup	Setup PS2 Mouse and reset KB
34	Reserved	
35	Test DMA Controller 0	Test DMA Controller 0
36	Reserved	
37	Test DMA Controller 1	Test DMA Controller 1
38	Reserved	
39	Test DMA Page Registers	Test DMA Page Registers.
3A	Reserved	
3B	Reserved	
3C	Test Timer Counter 2	Test 8254 Timer 0 Counter 2.
3D	Reserved	
3E	Test 8259-1 Mask Bits	Verify 8259 Channel 1 masked interrupts by alternately turning off and on the interrupt lines.
3F	Reserved	
40	Test 8259-2 Mask Bits	Verify 8259 Channel 2 masked interrupts by alternately turning off and on the interrupt lines.
41	Reserved	
42	Reserved	

ECM-LX800D

Code (hex)	Name	Description
43	Test Stuck 8259's Interrupt Bits Test 8259 Interrupt Functionality	Turn off interrupts then verify no interrupt mask register is on. Force an interrupt and verify the interrupt occurred.
44	Reserved	
45	Reserved	
46	Reserved	
47	Set EISA Mode	If EISA non-volatile memory checksum is good, execute EISA initialization. If not, execute ISA tests and clear EISA mode flag.
48	Reserved	
49	Size Base and Extended Memory	Size base memory from 256K to 640K and extended memory above 1MB.
4A	Reserved	
4B	Reserved	
4C	Reserved	
4D	Reserved	
4E	Test Base and Extended Memory	Test base memory from 256K to 640K and extended memory above 1MB using various patterns. NOTE: This test is skipped in EISA mode and can be skipped with ESC key in ISA mode.
4F	Reserved	
50	USB init	Initialize USB controller
51	Reserved	
52	Memory Test	Test all memory of memory above 1MB using Virtual 8086 mode, page mode and clear the memory
53	Reserved	
54	Reserved	
55	CPU display	Detect CPU speed and display CPU vendor specific version string and turn on all necessary CPU features
56	Reserved	
57	PnP Init	Display PnP logo and PnP early init
58	Reserved	
59	Setup Virus Protect	Setup virus protect according to Setup
5A	Reserved	
5B	Awdflash Load	If required, will auto load Awdflash.exe in POST
5C	Reserved	
5D	Onboard I/O Init	Initializing onboard superIO

Code (hex)	Name	Description
5E	Reserved	
5F	Reserved	
60	Setup enable	Display setup message and enable setup functions
61	Reserved	
62	Reserved	
63	Initialize & Install Mouse	Detect if mouse is present, initialize mouse, install interrupt vectors.
64	Reserved	
65	PS2 Mouse special	Special treatment to PS2 Mouse port
66	Reserved	
67	ACPI init	ACPI sub-system initializing
68	Reserved	
69	Setup Cache Controller	Initialize cache controller.
6A	Reserved	
6B	Setup Entering	Enter setup check and auto- configuration check up
6C	Reserved	
6D	Initialize Floppy Drive & Controller	Initialize floppy disk drive controller and any drives.
6E	Reserved	
6F	FDD install	Install FDD and setup BIOS data area parameters
70	Reserved	
71	Reserved	
72	Reserved	
73	Initialize Hard Drive & Controller	Initialize hard drive controller and any drives.
74	Reserved	
75	Install HDD	IDE device detection and install
76	Reserved	
77	Detect & Initialize Serial/Parallel Port	Initialize any serial and parallel ports (also game port).
78	Reserved	
79	Reserved	
7A	Detect & Initialize Math Coprocessor	Initialize math coprocessor.
7B	Reserved	
7C	HDD Check for Write protection	HDD check out

ECM-LX800D

Code (hex)	Name	Description
7D	Reserved	
7E	Reserved	
7F	POST error check	Check POST error and display them and ask for user intervention
80	Reserved	
81	Reserved	
82	Security Check	Ask password security (optional).
83	Write CMOS	Write all CMOS values back to RAM and clear screen.
84	Pre-boot Enable	Enable parity checker. Enable NMI, Enable cache before boot.
85	Initialize Option ROMs	Initialize any option ROMs present from C8000h to EFFFFh. NOTE: When FSCAN option is enabled, ROMs initialize from C8000h to F7FFFh.
86	Reserved	
87	Reserved	
88	Reserved	
89	Reserved	
8A	Reserved	
8B	Reserved	
8C	Reserved	
8D	Reserved	
8E	Reserved	
8F	Reserved	
90	Reserved	
91	Reserved	
92	Reserved	
93	Boot Medium detection	Read and store boot partition head and cylinders values in RAM
94	Final Init	Final init for last micro details before boot
95	Special KBC patch	Set system speed for boot. Setup NumLock status according to Setup
96	Boot Attempt	Set low stack Boot via INT 19h.
FF	Boot	

40.2 Quick POST Codes

Code (hex)	Name	Description
65	Init onboard device	Early Initialized the super IO. Reset Video controller. Keyboard controller init Test the Keyboard Initialized the mouse Onboard audio controller initialize if exist. Check the intergraty of the ROM, BIOS and message Check Flash type and copy flash write/erase routines to 0F000h segments Check Cmos Circuitry and reset CMOS Program the chipset registers with CMOS values Init onboard clock generator
66	Early Sytem setup	Check the CPU ID and init L1/L2 cache. Initialize first 120 interrupt vectors with SPURIOUS_INT_HDLR and 10 initialize INT 00h-1Fh according to INT_TBL First step initialize if single CPU onboard. Re-init KB If support HPM, HPM get initialized here.
67	KBC and CMOS Init	Verifies CMOS is working correctly, detects bad battery. If failed, load CMOS defaults and load into chipset. Final Initial KBC and setup BIOS data area.
68	Video Init	Read CMOS location 14h to find out type of video in use. Detect and Initialize Video Adapter. Test video memory, write sign-on message to screen. Setup shadow RAM - Enable shadow according to Setup.
69	8259 Init	Init 8259 channel 1 and mask IRQ 9
6A	Memory test	Quick Memory Test
6B	CPU Detect and IO init	CPU vendor specific version string and turn on all necessary CPU features Display PnP logo and PnP early init Setup virus protect according to Setup. If required, will auto load Awdflash.exe in POST Initializing onboard superIO
6C	Reserved	
6D	Reserved	
6E	Reserved	
6F	Reserved	
70	Setup Init	Display setup message and enable setup functions Detect if mouse is present, initialize mouse, install interrupt vectors. Special treatment to PS2 Mouse port ACPI sub-system initializing
71	Setup Cache Controller	Initialize cache controller.

ECM-LX800D

Code (hex)	Name	Description
72	Install FDD	Enter setup check and auto11 configuration check up Initialize floppy disk drive controller and any drives. Install FDD and setup BIOS data area parameters
73	Install FDD	Initialize hard drive controller and any drives. IDE device detection and install Initialize any serial and parallel ports (also game port).
74	Detect & Initialize Math Coprocessor	Initialize math coprocessor.
75	HDD Check for Write protection	HDD check out
76	Reserved	
77	Display POST error	Check POST error and display them and ask for user intervention Ask password security (optional).
78	CMOS and Option ROM Init	Write all CMOS values back to RAM and clear screen. Enable parity checker Enable NMI, Enable cache before boot. Initialize any option ROMs present from C8000h to EFFFFh. NOTE: When FSCAN option is enabled, ROMs initialize from C8000h to F7FFFh.
79	Reserved	
7A	Reserved	
7B	Reserved	
7C	Reserved	
7D	Boot Medium detection	Read and store boot partition head and cylinders values in RAM
7E	Final Init	Final init for last micro details before boot
7F	Special KBC patch	Set system speed for boot. Setup NumLock status according to Setup.
80	Boot Attempt	Set low stack Boot via INT 19h.
FF	Boot	

40.3S4 POST Codes

Code (hex)	Name	Description
5A	Early Chipset Init	Early Initialized the super IO. Reset Video controller. Keyboard controller init. Test the Keyboard Initilized the mouse
5B	Cmos Check	Check Cmos Circuitry and reset CMOS
5C	Chipset default Prog	Program the chipset registers with CMOS values. Init onboard clock generator
5D	Identify the CPU	Check the CPU ID and init L1/L2 cache Initialize first 120 interrupt vectors with SPURIOUS_INT_HDLR and INT 00h-1Fh according to INT_TBL. First step initialize if single CPU Onboard. Re-init KB If support HPM, HPM get initialized Here.
5E	Setup Interrupt Vector Table	Initialize first 120 interrupt vectors with SPURIOUS_INT_HDLR and INT 00h-1Fh according to INT_TBL. First step initialize if single CPU Onboard. Re-init KB If support HPM, HPM get initialized here.
5F	Test CMOS Interface and Battery status	Verifies CMOS is working correctly, detects bad battery. If failed, load CMOS defaults and load into chipset.
60	KBC final Init	Final Initial KBC and setup BIOS data area
61	Initialize Video Interface	Read CMOS location 14h to find out type of video in use. Detect and Initialize Video Adapter.
62	Video memory test	Test video memory, write sign-on Test video memory, write sign-on message to screen. Setup shadow RAM - Enable shadow according to Setup.
63	Setup PS2 mouse and test DMA	Setup PS2 Mouse and reset KB Test DMA channel 0
64	Test 8259	Test 8259 channel 1 and mask IRQ 9
65	Init Boot Device	Detect if mouse is present, initialize mouse, install interrupt vectors. Special treatment to PS2 Mouse port ACPI sub-system initializing Initialize cache controller.
66	Install Boot Devices	Enter setup check and auto-configuration check up Initialize floppy disk drive controller and any drives. Install FDD and setup BIOS data area Parameters Initialize hard drive controller and any drives. IDE device detection and install
67	Cache Init	Cache init and USB init
68	PM init	PM initialization
69	PM final Init and issue SMI	Final init Before resume
FF	Full on	

ECM-LX800D

40.4 BootBlock POST Codes

Code (hex)	Name	Description
1	Base memory test	Clear base memory area (0000:0000--9000:ffffh)
5	KB init	Initialized KBC
12	Install interrupt vectors	Install int. vector (0-77), and initialized 00-1fh to their proper place
0D	Init Video	Video initializing
41	Init FDD	Scan floppy and media capacity for onboard superIO
FF	Boot	Load boot sector