

Inclinometer with CANopen interface B2N60H-Q42-CNX2-2H1150

TURCK
works

Industrial
Automation

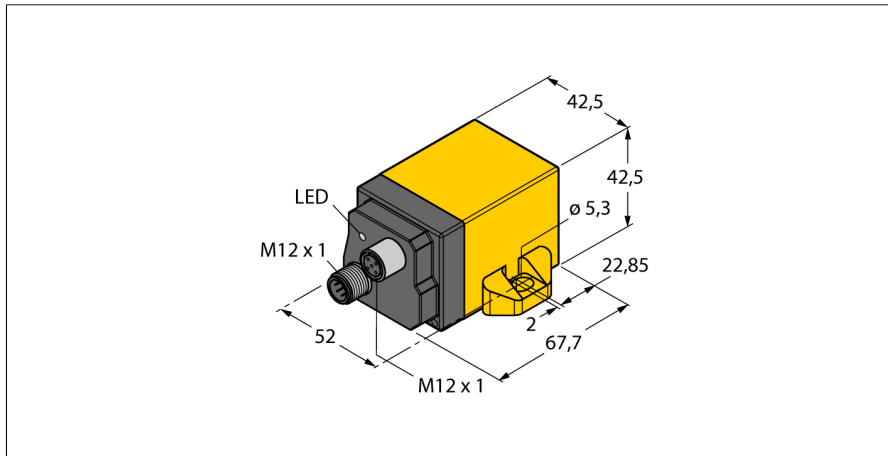

- Rectangular, height 42 mm
- Plastic, PBT-GF30-V0
- Convenient CANopen interface
- Fulfills CiA DS-301, CiA DSP-410
- High resolution and accuracy
- Baud rates of 10 kbps up to 1 Mbps
- High sampling rate and bandwidth
- Configurable vibrostability
- One TPDO (RTR, cyclic, event-controlled, synchronized)
- Configuration via SDO and object directory
- SYNC consumer (synchronized transmission of TPDO after reception of SYNC telegram)
- EMCY producer (inclination, internal device temperature monitoring)
- Failure monitoring via heartbeat or nodeguarding/lifeguarding
- Freely configurable limit frequency (digital filter)
- Robust and compact plastic housing

Type code	B2N60H-Q42-CNX2-2H1150
Ident-No.	1534063
Ident-No (TUSA)	M1534063
Measuring range	0...60°
Measuring range x-axis	-60...60°
measuring range y-axis	-60...60°
Linearity deviation	max. ± 0.4 °
Temperature coefficient typical	0.008 °/K
Resolution	≤ 0.1 °
Ambient temperature	-40...+80 °C
Operating voltage	10...30VDC
Limit frequency	typ. 20 Hz, 2.(without digital filter) 0.3 ... 25 Hz, 8. (with Butterworth, low-pass) The digital filter is deactivated with the value 0. Values between 300 (= 0.3 Hz) and 25000 (= 25 Hz) are allowed.
Interface	CANopen
Node ID	1...127
Baud rate	10 kbps up to 1 Mbps admissible values 10 kbps, 20 kbps, 50 kbps, 125 kbps, 250 kbps, 500 kbps, 800 kbps and 1000 kbps
Sample rate	100 Hz
Design	rectangular, Q42
Dimensions	68 x 52 x 42 mm
Housing material	plastic, PA
Vibration resistance	55 Hz (1 mm)
Shock resistance	30 g (11 ms)
Protection class	IP68 / IP69K
MTTF	55 years
Power-on indication	LED green
Error indication	LED red

Wiring diagram

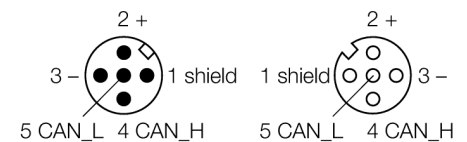

Functional principle

Inclination is determined by a wear-free semi-conducting sensor element.

For more technical details, please download the manual from our website.