

Phototransistor im MIDLED-Gehäuse
Phototransistor in MIDLED package
Lead (Pb) Free Product - RoHS Compliant

SFH 3600
SFH 3605

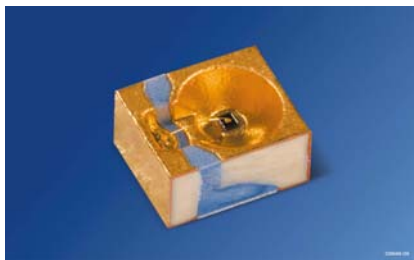

SFH 3600

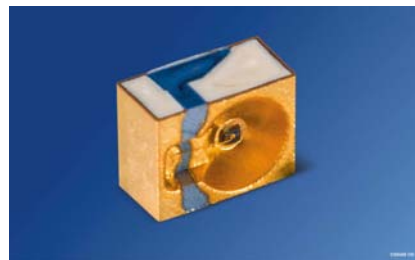

SFH 3605

Wesentliche Merkmale

- Enger Empfangswinkel ($\pm 20^\circ$)
- Geringe Bauhöhe (1,6 mm)
- Als Toplooker und Sidelooker einsetzbar
 SFH 3600: Gurtung als Toplooker
 SFH 3605: Gurtung als Sidelooker
- Emitter im gleichen Gehäuse (SFH 46xx) verfügbar

Anwendungen

- Lichtschranken, Lichtvorhänge
- Sensorik (Consumer, Industrieelektronik)
- Automobilanwendungen
- Näherungssensor

Features

- Narrow angle ($\pm 20^\circ$)
- Low profile component (1,6 mm)
- Usable as top-looking and side-looking device
 SFH 3600: Taping as Toplooker
 SFH 3605: Taping as Sidelooker
- Emitter in same package (SFH 46xx) available

Applications

- Interrupters, Lightcurtains
- Sensors (Consumer, Industrial applications)
- Automotive applications
- proximity sensor

Typ Type	Bestellnummer Ordering Code	Fotostrom , ($E_e=0.1 \text{ mW/cm}^2, \lambda=950 \text{ nm } V_{CE} = 5 \text{ V}$) Photocurrent $I_{pce} (\mu\text{A})$
SFH 3600 ¹⁾	Q65110A1573	100-500
SFH 3600 -2/3 ¹⁾	Q65110A2665	100-320
SFH 3600 -3/4 ¹⁾	Q65110A2666	160-500
SFH 3605 ¹⁾	Q65110A1574	100-500
SFH 3605 -2/3 ¹⁾	Q65110A2663	100-320
SFH 3605 -3/4 ¹⁾	Q65110A2664	160-500

¹⁾ nur eine Gruppe in einer Verpackungseinheit (Streuung kleiner 2:1) / only one group in one packing unit (variation lower 2:1)

Grenzwerte Maximum Ratings

Bezeichnung Parameter	Symbol Symbol	Wert Value	Einheit Unit
Betriebs- und Lagertemperatur Operating and storage temperature range	$T_{op}; T_{stg}$	- 40 ... + 100	°C
Kollektor-Emitterspannung Collector-emitter voltage	V_{CE}	35	V
Kollektorstrom Collector current	I_C	15	mA
Kollektorspitzenstrom, $\tau < 10 \mu s$ Collector surge current	I_{CS}	75	mA
Emitter-Kollektorspannung Emitter-collector voltage	V_{EC}	7	V
Verlustleistung, $T_A = 25 \text{ °C}$ Total power dissipation	P_{tot}	130	mW
Wärmewiderstand Sperrschicht/Umgebung ¹⁾ Thermal resistance junction	R_{thJA}	340	K/W
Wärmewiderstand Sperrschicht/Lötstelle ²⁾ Thermal resistance junction	R_{thJS}	180	K/W

¹⁾ bei Montage auf FR4 Platine, Padgröße je 16 mm² / when mounted on PC-board (FR4), padsize 16 mm² each

²⁾ bei Montage auf Metall-Block / when mounted on metal block

Kennwerte ($T_A = 25 \text{ °C}$)

Characteristics

Bezeichnung Parameter	Symbol Symbol	Wert Value	Einheit Unit
Wellenlänge der max. Fotoempfindlichkeit Wavelength of max. sensitivity	$\lambda_{S \max}$	990	nm
Spektraler Bereich der Fotoempfindlichkeit $S = 10\%$ von S_{\max} Spectral range of sensitivity $S = 10\%$ of S_{\max}	λ	500 ... 1100	nm
Bestrahlungsempfindliche Fläche Radiant sensitive area	A	0.04	mm ²
Abmessungen des Chips Dimensions of chip	$L \times B \times H$ $L \times W \times H$	0.35×0.35 $\times 0.185$	mm × mm × mm

Kennwerte ($T_A = 25\text{ °C}$)
Characteristics (cont'd)

Bezeichnung Parameter	Symbol Symbol	Wert Value	Einheit Unit
Halbwinkel Half angle	φ	± 20	Grad deg.
Kapazität, $V_{CE} = 5\text{ V}$, $f = 1\text{ MHz}$, $E = 0$ Capacitance	C_{CE}	1.3	pF
Dunkelstrom Dark current $V_{CE} = 20\text{ V}$, $E = 0$	I_{CEO}	1 (≤ 50)	nA

Die Fototransistoren werden nach ihrer Fotoempfindlichkeit gruppiert und mit arabischen Ziffern gekennzeichnet.

The phototransistors are grouped according to their spectral sensitivity and distinguished by arabian figures.

Bezeichnung Parameter	Symbol Symbol	Wert Value			Einheit Unit
		-2	-3	-4	
Fotostrom, $\lambda = 950\text{ nm}$ Photocurrent $E_e = 0.1\text{ mW/cm}^2$, $V_{CE} = 5\text{ V}$	I_{PCE}	100 .. 200	160 ... 320	250 ... 500	μA
Anstiegszeit/Abfallzeit, $\lambda = 950\text{ nm}$ Rise and fall time $I_C = 100\text{ }\mu\text{A}$, $V_{CC} = 5\text{ V}$, $R_L = 10\text{ k}\Omega$	t_r , t_f	30	45	70	μs
Kollektor-Emitter-Sättigungsspannung Collector-emitter saturation voltage $I_C = I_{PCEmin}^{1)} \times 0.3$, $E_e = 0.1\text{ mW/cm}^2$, $\lambda = 950\text{ nm}$	V_{CEsat}	150	150	150	mV

¹⁾ I_{PCEmin} ist der minimale Fotostrom der jeweiligen Gruppe / I_{PCEmin} is the min. photocurrent of the specified group.

Directional Characteristics

$S_{rel} = f(\varphi)$

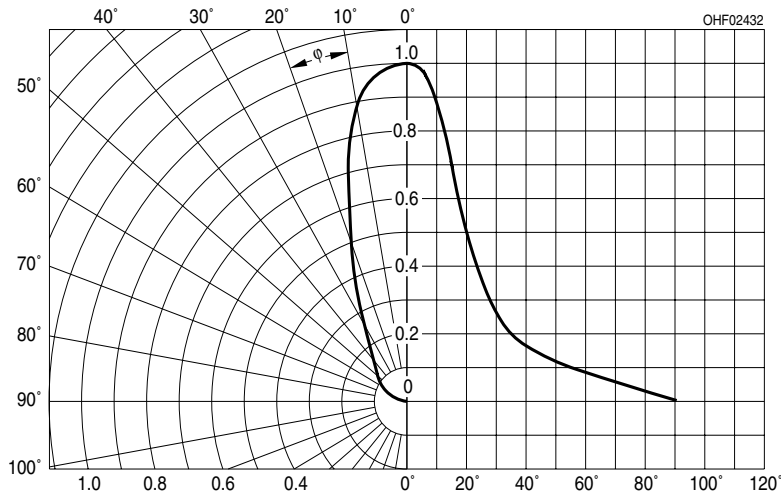

Rel. Spectral Sensitivity, $S_{rel} = f(\lambda)$, axial direction

$S_{rel} = f(\lambda)$, axial direction

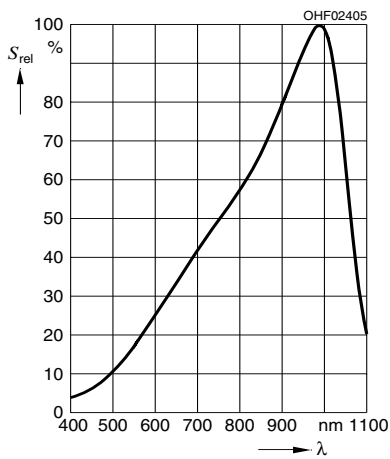

Dark Current $I_{CEO} = f(V_{CE}), E = 0$

$I_{CEO} = f(V_{CE}), E = 0$

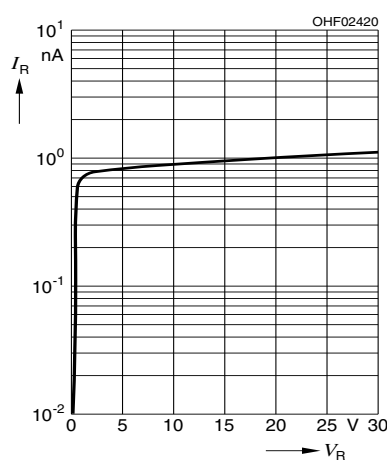

Dark Current $I_{CEO} = f(T_A), V_{CE} = 20 V, E = 0$

$I_{CEO} = f(T_A), V_{CE} = 20 V, E = 0$

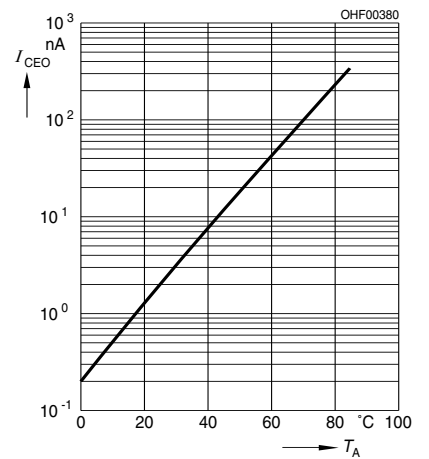

Photocurrent $I_{PCE} = f(T_A), V_{CE} = 5 V$, normalized to 25 °C

$I_{PCE} = f(T_A), V_{CE} = 5 V$, normalized to 25 °C

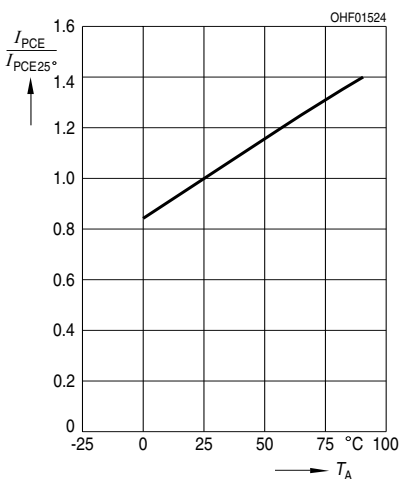

Collector-Emitter Capacitance $C_{CE} = f(V_{CE}), f = 1 MHz$

$C_{CE} = f(V_{CE}), f = 1 MHz$

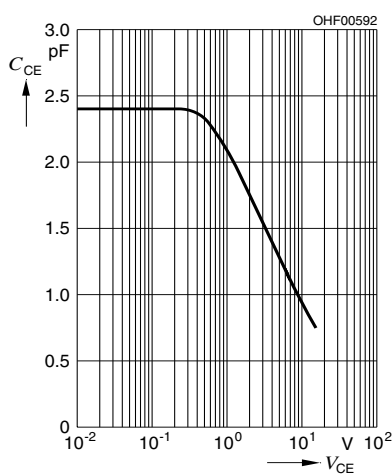

Maßzeichnung
Package Outlines

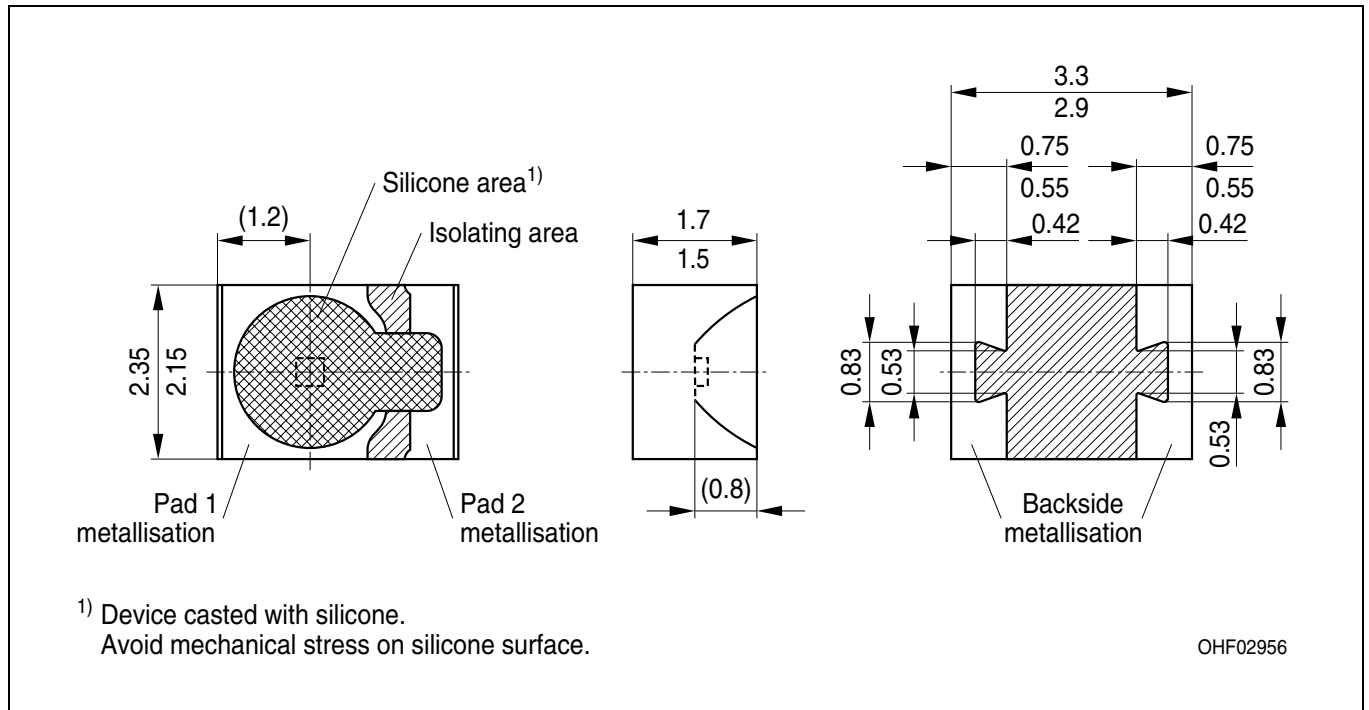

Maße werden wie folgt angegeben: mm (inch) / Dimensions are specified as follows: mm (inch).

Gehäuse package	MID mit klarem Silikonverguss MID casted with clear Silicone
Anschlussbelegung Pin configuration	Pad 1 = Kollektor / collector Pad 2 = Emitter / emitter

1) Verarbeitungshinweis:

Das Gehäuse ist mit Silikon vergossen. Mechanischer Streß auf der Bauteiloberfläche sollte so gering wie möglich gehalten werden.

1) Handling indication:

The package is casted with silicone. Mechanical stress at the surface of the unit should be as low as possible.

Empfohlenes Lötpaddesign
Recommended Solder Pad Design

Verarbeitet als Toplooker
 Mounted as toplooker

SFH 3600

Padgeometrie für verbesserte Wärmeableitung
 Paddesign for improved heat dissipation

Cu-Fläche > 16 mm²
 Cu-area

 Lötstopplack
 Solder resist

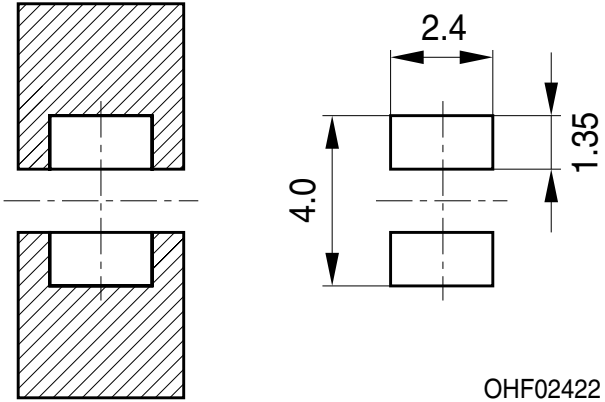

OHF02422

Verarbeitet als Sidelooker
 Mounted as sidelooker

SFH 3605

Padgeometrie für verbesserte Wärmeableitung
 Paddesign for improved heat dissipation

Cu-Fläche > 16 mm²
 Cu-area

 Lötstopplack
 Solder resist

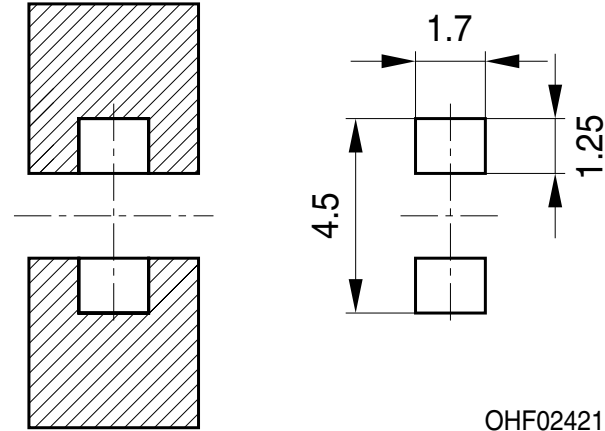

OHF02421

Lötbedingungen
Soldering Conditions
IR-Reflow Lötprofil für bleifreies Löten
IR Reflow Soldering Profile for lead free soldering

Vorbehandlung nach JEDEC Level 2
 Preconditioning acc. to JEDEC Level 2
 (nach J-STD-020B)
 (acc. to J-STD-020B)

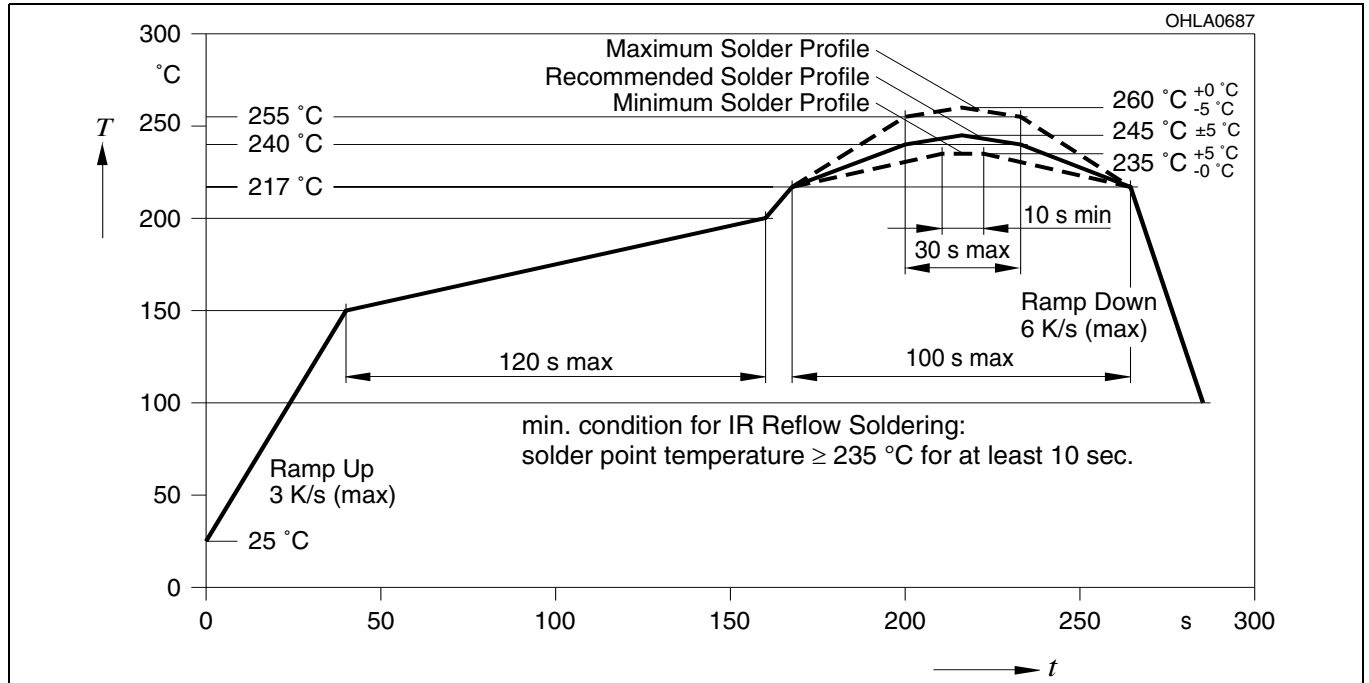

Published by
OSRAM Opto Semiconductors GmbH
 Wernerwerkstrasse 2, D-93049 Regensburg
www.osram-os.com

© All Rights Reserved.

The information describes the type of component and shall not be considered as assured characteristics. Terms of delivery and rights to change design reserved. Due to technical requirements components may contain dangerous substances. For information on the types in question please contact our Sales Organization.

Packing

Please use the recycling operators known to you. We can also help you – get in touch with your nearest sales office. By agreement we will take packing material back, if it is sorted. You must bear the costs of transport. For packing material that is returned to us unsorted or which we are not obliged to accept, we shall have to invoice you for any costs incurred.

Components used in life-support devices or systems must be expressly authorized for such purpose! Critical components ¹, may only be used in life-support devices or systems ² with the express written approval of OSRAM OS.

¹ A critical component is a component used in a life-support device or system whose failure can reasonably be expected to cause the failure of that life-support device or system, or to affect its safety or effectiveness of that device or system.

² Life support devices or systems are intended (a) to be implanted in the human body, or (b) to support and/or maintain and sustain human life. If they fail, it is reasonable to assume that the health of the user may be endangered.