

# EBR7912EBI-CA-KA

## Incremental Sensor Module with Reference

The sensor module EBR7912EBI-CA contains an Anisotropic MagnetoResistive (AMR) FixPitch sensor AL796 with 2 mm magnetic pitch and a Giant MagnetoResistive (GMR) sensor GF705 for the reference signal. The sensor module has an JST-connector with all necessary connections and two holes at the edges of the circuit board for mounting. The sensor module is calibrated, so you will get signals with a high performance and low jitter. The used ASIC is fully programmable and changes (for example the resolution) can be done with a programming tool.

When used with the magnetic scale MWR0032KAC-KH with 2 mm pitch, the module delivers two differential rectangular signals (A and B) and a differential reference pulse (Z) per revolution. The flank-to-flank resolution of the incremental signal is 0.088 deg.

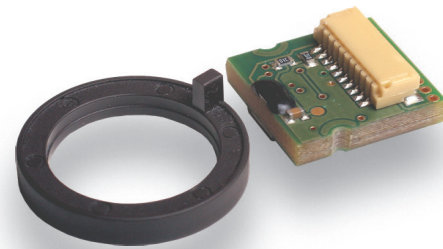

### Product Overview

Article description	Article number
EBR7912EBI-CA-KA	5112.3101.0
MWR0032KAC-KH incremental pole ring with reference <sup>1)</sup>	5109.6001.0

<sup>1)</sup> Matching pole ring.

### Quick Reference Guide

Symbol	Parameter	Min.	Typ.	Max.	Unit
$V_{CC}$	Supply voltage	3.0	3.3 / 5.0	5.5	V
$I_C$	Current consumption ( $V_{CC} = 5\text{ V}$ )	-	11	12	mA
A	Resolution (flank to flank)	-	0.088	-	deg
F	Flanks per revolution	-	4096	-	-
$f_{out}$	Output frequency	-	145	-	kHz
$T_{amb}$	Ambient temperature	-40	-	+105	°C

### Measurement Setup

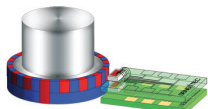
Depiction	Configuration	Application
	Magnetic pole ring with fixed pole pitch; sensor positioned radially; sensor face in the plane of rotation	Incremental angle measurement

### Features

- Resolution 4096 flanks per revolution
- Differential A/B output signal (digital)
- Reference output signal (Z) once per revolution
- Ambient temperature range from -40 to +105 °C
- Supply voltage 5.0 V or 3.3 V

### Advantages

- Easy to mount
- Integrated reference signal
- Very small size

### Applications

Incremental encoder for rotating movements in various applications, for example:

- Motor feedback system
- Motor integrated encoder



## Absolute Maximum Ratings

In accordance with the absolute maximum rating system (IEC60134).

Symbol	Parameter	Min.	Max.	Unit
$V_{CC}$	Supply voltage	-0.3	+6.0	V
$T_{amb}$	Ambient temperature	-40	+105	°C

Stresses beyond those listed under "absolute maximum ratings" may cause permanent damage to the device. This is a stress rating only and functional operation of the device at these or any other conditions beyond those indicated in the operational sections of this specification is not implied. Exposure to absolute maximum rating conditions for extended periods may affect device reliability.

## Electrical Data

$T_{amb} = 25\text{ °C}$ ;  $H_{ext} = 25\text{ kA/m}$ ;  $V_{CC} = 5\text{ V}$ ; unless otherwise specified.

Symbol	Parameter	Conditions	Min.	Typ.	Max.	Unit
$V_{CC}$	Supply voltage		3.0	3.3 5.0	5.5	V
$I_c$	Current consumption	5.0 V, no load	-	11	12	mA
$I_c$	Current consumption	3.3 V, no load	-	8	9	mA
A	Resolution (flank to flank)		-	0.088	-	deg
F	Flanks per revolution		-	4096	-	-
$f_{out}$	Output frequency	$N = 8500\text{ min}^{-1}$	-	145	-	kHz
$T_{amb}$	Ambient temperature		-40	-	+105	°C
$I_{out,pin}$	Permissible load current (source and sink)		-10	-	+10	mA
$V_{outH}$	Output high level	$V_{CC} = 5\text{ V}$ , $I_{source} = 6\text{ mA}$	4.6	-	5.0	V
$V_{outL}$	Output low level	$V_{CC} = 5\text{ V}$ , $I_{sink} = 6\text{ mA}$	0.0	-	0.25	V
$V_{outH}$	Output high level	$V_{CC} = 3.3\text{ V}$ , $I_{source} = 6\text{ mA}$	2.8	-	3.3	V
$V_{outL}$	Output low level	$V_{CC} = 3.3\text{ V}$ , $I_{sink} = 6\text{ mA}$	0.0	-	0.3	V
$t_{Lat}$	Latency		-	-	<1	µs

## Accuracy

$T_{amb} = -40\dots+105\text{ °C}$ ;  $H_{ext} = 25\text{ kA/m}$ ;  $V_{CC} = 5\text{ V}$ ; unless otherwise specified.

Symbol	Parameter	Conditions	Min.	Typ.	Max.	Unit
$\Delta\alpha$	Absolute accuracy <sup>1)</sup>		-	-	±1	deg
R	Repeatability <sup>1)</sup>		-	-	±1	deg
$\Delta\Pi$	Deviation of pulse width <sup>1)</sup>	See Fig. 3	-	±9	±40	deg
$\Delta\phi$	Deviation of phase shift <sup>1)</sup>	See Fig. 3	-	±6	±43	deg

<sup>1)</sup> Matching pole ring.

## Mechanical Data

Symbol	Parameter	Conditions	Min.	Typ.	Max.	Unit
N	Rotational speed	$V_{CC} \geq 3.3\text{ V}$	-	-	8500	min <sup>-1</sup>
$\Delta_{radial}$	Working distance (scale surface ↔ sensor)	See Fig. 7	100	400	700	µm
$\Delta_{axial}$	Axial tolerance	See Fig. 7	-500	-	+900	µm

Typical Performance Graphs

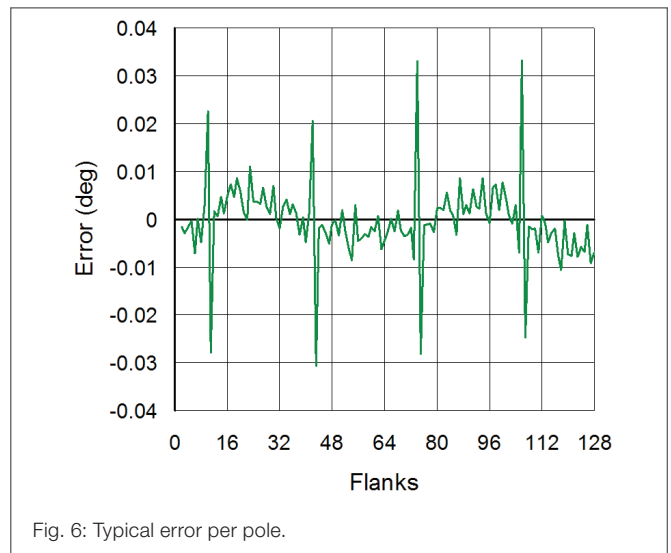
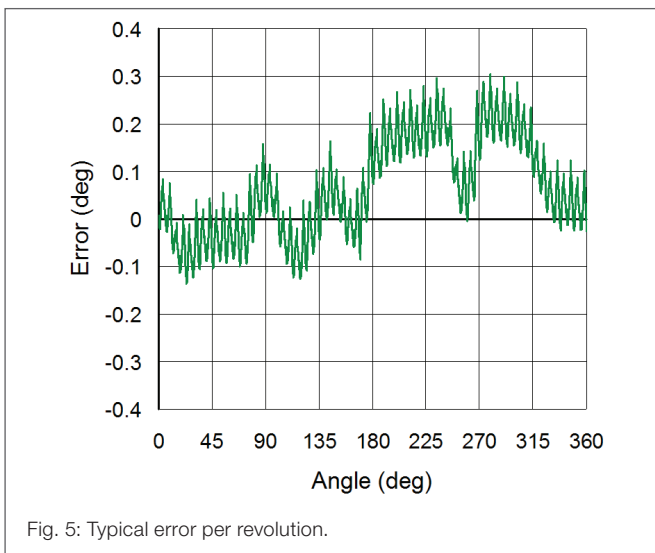
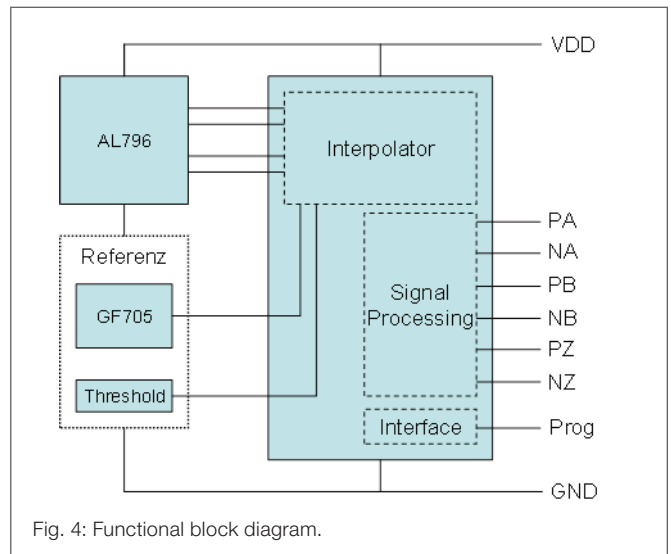
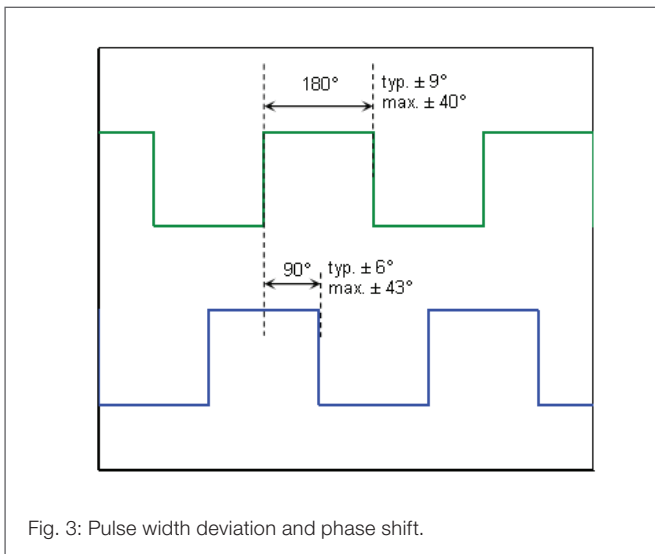
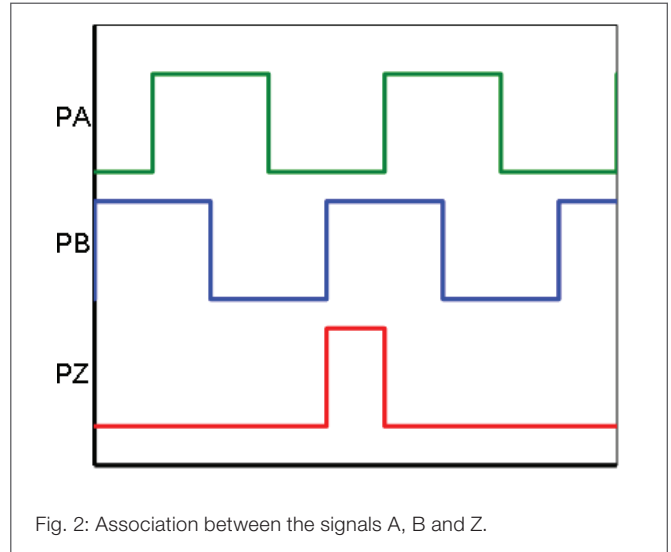
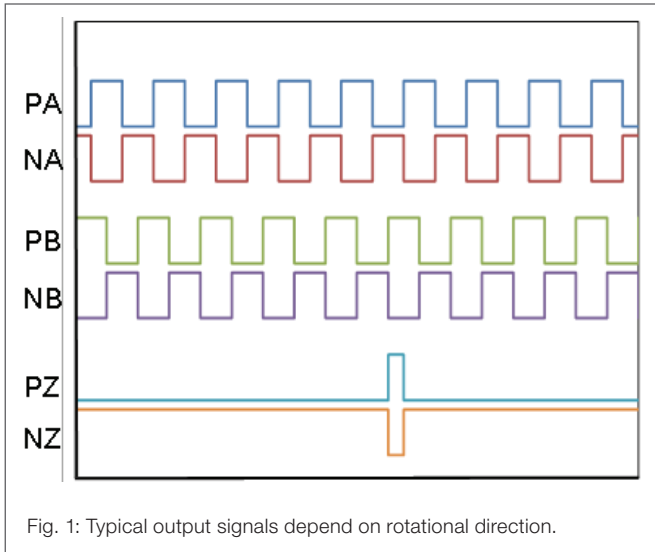

**Dimensions of EBR7912 with Pole Ring MWR0032KAC**

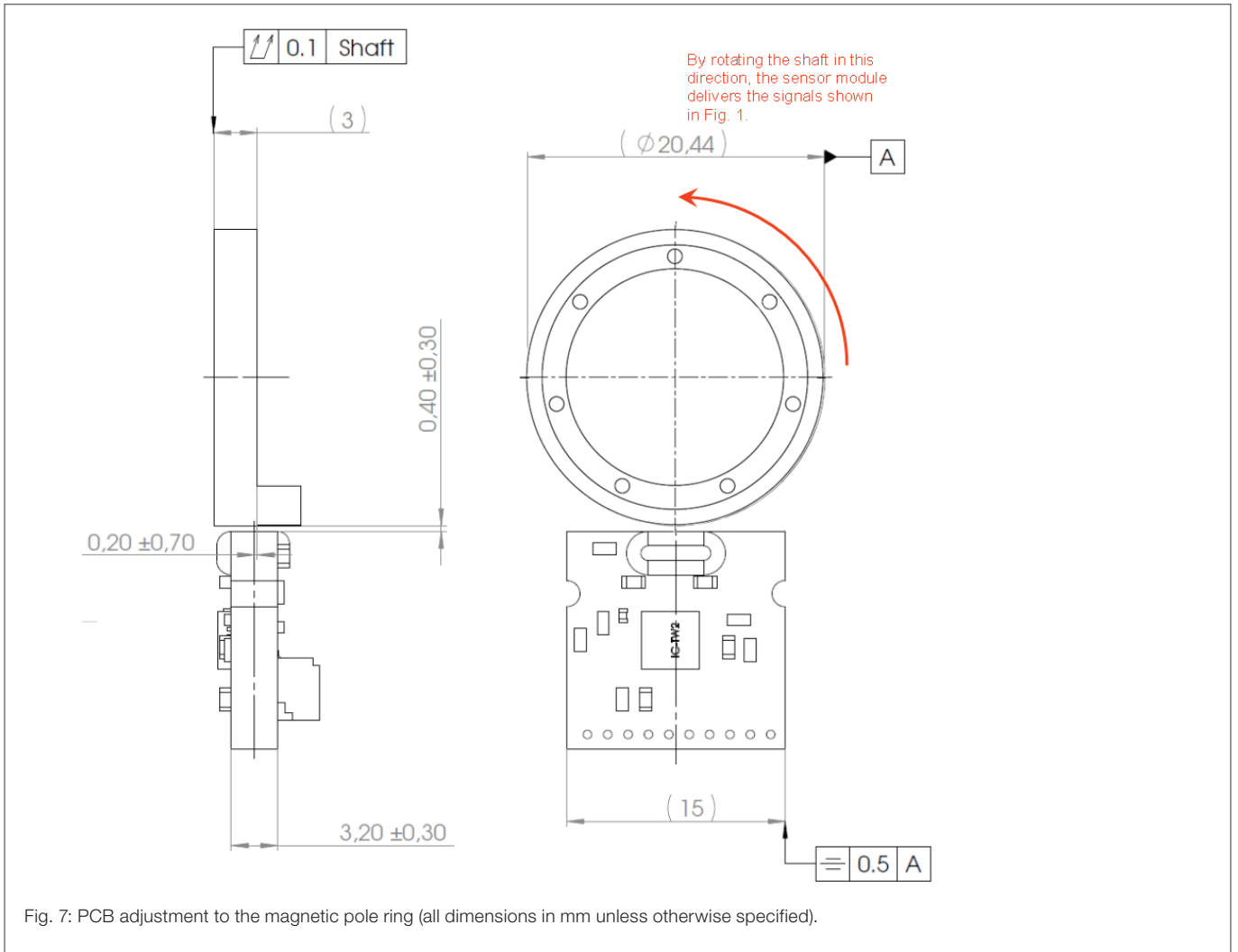

## Pinning and Dimensions of the Sensor Module EBR7912EBI-CA-KA

### Pinning

Pad	Symbol	Parameter
1	PZ	Positive output signal Z
2	NZ	Negative output signal Z
3	PA	Positive output signal A
4	NA	Negative output signal A
5	PB	Positive output signal B
6	NB	Negative output signal B
7	GND	Ground
8	V <sub>CC</sub>	Supply voltage
9	SCL	Communication interface: clock <sup>1)</sup>
10	SDA	Communication interface: data <sup>1)</sup>

<sup>1)</sup> Use only with suitable programming adapter.

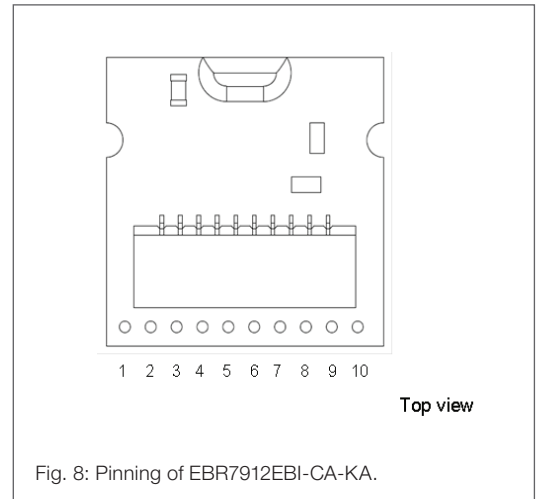

Fig. 8: Pinning of EBR7912EBI-CA-KA.

### Dimensions

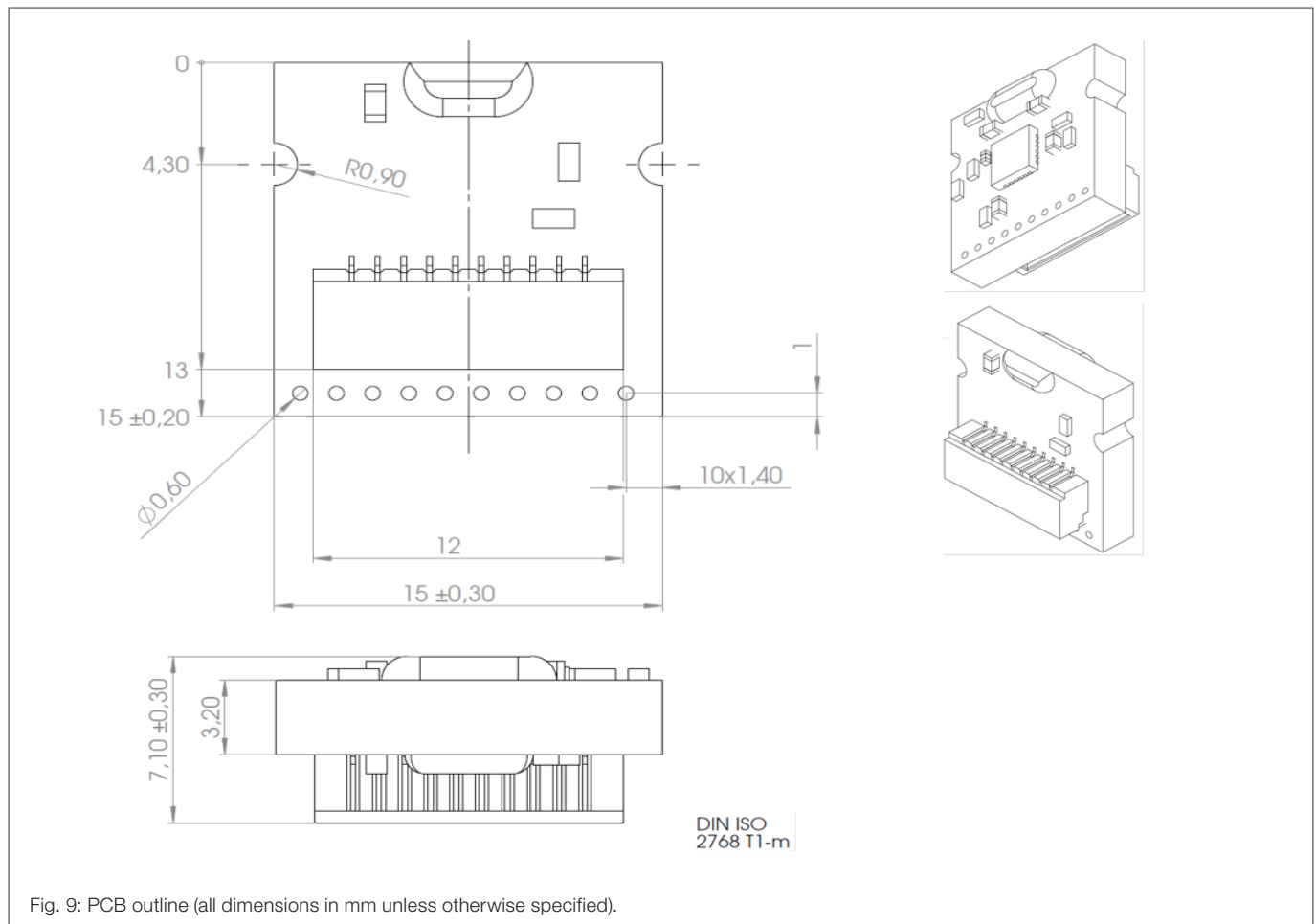

Fig. 9: PCB outline (all dimensions in mm unless otherwise specified).

**Magnetic Data**

Symbol	Parameter	Conditions	Min.	Typ.	Max.	Unit
$H_{ext}$	Magnetic field strength <sup>1)</sup>		30	35	40	kA/m

<sup>1)</sup> Typical magnetic field strength of the pole ring MWR0032KAC-KH.

**Dimensions**

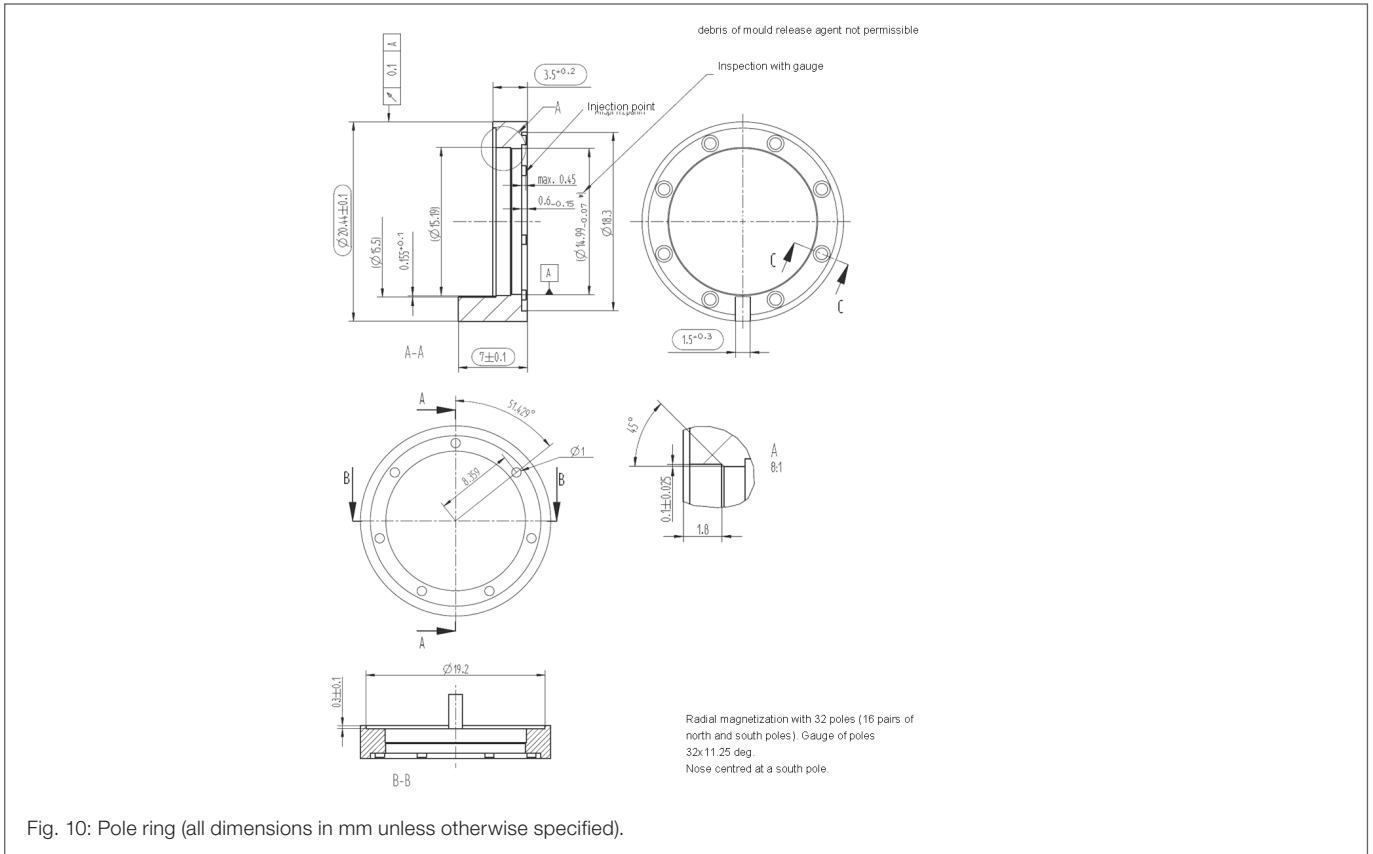

Fig. 10: Pole ring (all dimensions in mm unless otherwise specified).

## General Information

### Product Status

Article	Status
EBR7912EBI-CA-KA Incremental sensor module	The product is in series production.
MWR0032-KAC-KH Incremental pole ring with reference	The product is in series production.
<b>Note</b>	The status of the product may have changed since this data sheet was published. The latest information is available on the internet at <a href="http://www.sensitec.com">www.sensitec.com</a> .

### Disclaimer

Sensitec GmbH reserves the right to make changes, without notice, in the products, including software, described or contained herein in order to improve design and/or performance. Information in this document is believed to be accurate and reliable. However, Sensitec GmbH does not give any representations or warranties, expressed or implied, as to the accuracy or completeness of such information and shall have no liability for the consequences of use of such information. Sensitec GmbH takes no responsibility for the content in this document if provided by an information source outside of Sensitec products.

In no event shall Sensitec GmbH be liable for any indirect, incidental, punitive, special or consequential damages (including but not limited to lost profits, lost savings, business interruption, costs related to the removal or replacement of any products or rework charges) irrespective the legal base the claims are based on, including but not limited to tort (including negligence), warranty, breach of contract, equity or any other legal theory.

Notwithstanding any damages that customer might incur for any reason whatsoever, Sensitec product aggregate and cumulative liability towards customer for the products described herein shall be limited in accordance with the General Terms and Conditions of Sale of Sensitec GmbH. Nothing in this document may be interpreted or construed as an offer to sell products that is open for acceptance or the grant, conveyance or implication of any license under any copyrights, patents or other industrial or intellectual property rights.

Unless otherwise agreed upon in an individual agreement Sensitec products sold are subject to the General Terms and Conditions of Sales as published at [www.sensitec.com](http://www.sensitec.com).

### Sensitec GmbH

Georg-Ohm-Str. 11 · 35633 Lahnau · Germany  
 Tel. +49 6441 9788-0 · Fax +49 6441 9788-17  
[www.sensitec.com](http://www.sensitec.com) · [sensitec@sensitec.com](mailto:sensitec@sensitec.com)



## General Information

### Application Information

Applications that are described herein for any of these products are for illustrative purposes only. Sensitec GmbH makes no representation or warranty – whether expressed or implied – that such applications will be suitable for the specified use without further testing or modification.

Customers are responsible for the design and operation of their applications and products using Sensitec products, and Sensitec GmbH accepts no liability for any assistance with applications or customer product design. It is customer's sole responsibility to determine whether the Sensitec product is suitable and fit for the customer's applications and products planned, as well as for the planned application and use of customer's third party customer(s). Customers should provide appropriate design and operating safeguards to minimize the risks associated with their applications and products.

Sensitec GmbH does not accept any liability related to any default, damage, costs or problem which is based on any weakness or default in the customer's applications or products, or the application or use by customer's third party customer(s). Customer is responsible for doing all necessary testing for the customer's applications and products using Sensitec products in order to avoid a default of the applications and the products or of the application or use by customer's third party customer(s).

Sensitec does not accept any liability in this respect.

### Life Critical Applications

These products are not qualified for use in life support appliances, aeronautical applications or devices or systems where malfunction of these products can reasonably be expected to result in personal injury.

### Copyright © 2015 by Sensitec GmbH, Germany

All rights reserved. No part of this document may be copied or reproduced in any form or by any means without the prior written agreement of the copyright owner. The information in this document is subject to change without notice. Please observe that typical values cannot be guaranteed. Sensitec GmbH does not assume any liability for any consequence of its use.

#### Sensitec GmbH

Georg-Ohm-Str. 11 · 35633 Lahnau · Germany  
Tel. +49 6441 9788-0 · Fax +49 6441 9788-17  
www.sensitec.com · sensitec@sensitec.com

